

Sierra Monitor offers a variety of accessories for gas sensor modules to aid the user in calibration, placement and use of gas sensor modules to ensure accurate and reliable monitoring of hazardous gases.

CALIBRATORS

1250-XX Calibrator Kit

The 1250-XX Calibrator Kit is used to deliver calibration gas for combustible gases and a wide variety of toxic gas detection modules including Carbon Monoxide, Hydrogen, Combustible Gas, Hydrogen Sulfide, Chlorine, Sulfur Dioxide, Nitric Oxide, Nitrogen Dioxide and Zero Grade Air. Other gases are available, contact Sierra Monitor for the latest information. There are three versions of the calibration kit available depending upon the specific calibration gas required. Each kit contains a regulator, calibration adapter and carrying case. The individual calibration gas cylinders (Series 1260) are sold separately.



**Model 1250-01 Calibration Kit
Type A (with cylinder)**

Specifications for 1260 Series Gas Cylinders

Type A Gas Cylinders (Combustible Gas – LEL, CO, H₂, Air)

- Dimensions (cylinder): 13.75 x 3.25 in. (34.9 x 8.2 cm)
- Weight (cylinder): 2.3 lb. (1.05 Kg)
- Cylinder Pressure: Max 1000 psig
- Cylinder Volume: 3.6 cu. ft. (105 liters) at STP

Type A Gas Cylinders (H₂S FOR 4101/5100-05)

- Dimensions (cylinder): 13.5 x 3.5 in. (34.3 x 8.9 cm)
- Weight (cylinder): 1.8 lb. (0.8 Kg)
- Cylinder Pressure: Max 500 psig
- Cylinder Volume: 2.0 cu. ft. (57 liters) at STP

Type B Gas Cylinders (SO₂, NO₂, NO)

- Dimensions (cylinder): 16.25 x 4.0 in. (41.3 x 10.2 cm)
- Weight (cylinder): 1.75 lb. (0.8 Kg)
- Cylinder Pressure: Max 480 psig
- Cylinder Volume: 2.6 cu. ft. (74 liters) at STP

Type C Gas Cylinders (Cl₂)

- Dimensions (cylinder): 12.25 x 3.25 in. (31.1 x 8.2 cm)
- Weight (cylinder): 2.2 lb. (1.0 Kg)
- Cylinder Pressure: Max 1800 psig
- Cylinder Volume: 3.7 cu. ft. (104 liters) at STP

1200-26 Calibration Gas Delivery System

The Model 1200-26 Calibration Gas Delivery System provides calibration gas for Combustible Gas, Carbon Monoxide, or Oxygen Deficiency gas detection monitors. This system consists of disposable pressure vessels (2 cylinders supplied with each system) containing calibration gas and a non-disposable pressure and flow regulation system. Gas flow is controlled in two steps with a regulator and flow meter to conserve gas and to accurately regulate flow.

The 1200-26 and the Methane calibration gas cylinders are approved for calibration of FM Approved Sierra Monitor Combustible Gas Sensors

Specifications for 1200-26

- Dimensions: 4.0 x 7.0 x 3.0 in. (10.2 x 17.8 x 7.6 cm)
- Weight: 2.75lb. (1.24kg.) (including cylinder)
- Flow Rate: 50-500 cc/min.
- Cylinder Pressure: Max 180 psi
- Cylinder Volume: 0.27 cu. ft. (7.7 liters) at STP

9210-00 Permeation Type Calibrator

The 9210-00 Permeation Type Calibrator with the individual permeation tube for the specific gas required offers a unique means of generating a desired gas. This device has the advantages of a wide selection of gas types, long life, and is an economical solution for the regular calibration of a large number of toxic sensors. Most popular applications are ammonia and hydrogen sulfide.



Model 1200-26



SAMPLE DRAW PRODUCTS

Sample draw products are used in applications in which the sensor cannot be installed directly at the gas sensing location due to poor accessibility or the harshness of the environment. Sample is continuously drawn from the sensing location to the sensor at a more suitable location.

The primary component of the sample draw product is a venturi manifold that uses a continuous flow of driver air to pull a slight vacuum through the sample supply line drawing the sample into the manifold cavity connected to the sensor.



5399-01 Sample Draw Fitting

The sample manifold assembly is the 5399-01 Sample Draw Fitting. Sample stream draw and flow control is provided by the user.

5398-01 Sample Draw Assembly

The 5398-01 Sample Draw Assembly is a complete sample draw assembly including the sample draw fitting, flow metering assembly, plus the driver air, sample and exhaust fittings. This allows accurate adjustment of sample flow using the signal flow meter located on the flow metering assembly.

5398-02 Sample Draw/Dilution Assembly

For applications where the expected gas concentration is either higher than maximum range of the sensor or sufficiently high to significantly reduce sensor life with extended exposure, the 5398-02 Sample Draw/Dilution Assembly is recommended. This assembly adds a second flow meter for control of dilution air. Adjustment of sample and dilution air flow meters achieves the dilution ratio required. Concentrations displayed on the sensor controller must then be multiplied by the dilution factor to arrive at actual concentrations.

SENSOR MOUNTING PRODUCTS

5360-00 Calibration Gas Delivery Fitting

The Calibration Gas Delivery Fitting provides the ability to deliver the gas to the sensor module in a remote location. A tube fitting enables the operator to direct calibrations gas flow to the sensor at any time desired.

5311-00 Rainshield

The Rainshield is mounted over the sensor head to protect the sensor from direct exposure to rain, hosedown and other splashing liquids.



5394-00 Duct Mount Fitting

The Duct Mount Fitting facilitates installation of the gas sensor module onto an air duct. The fitting also includes the 5360-00 calibration gas delivery fitting so that calibration gas can be delivered to the sensor without removing the module from the duct.

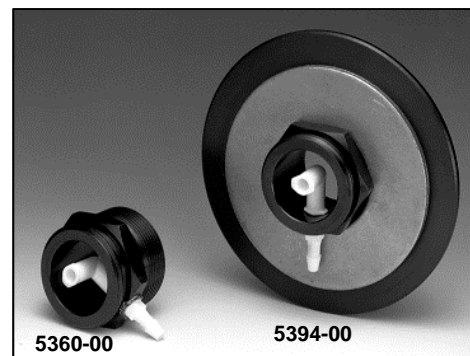

CALIBRATION ADAPTERS

The Sierra Monitor Gas sensor modules are designed for easy calibration. The standard calibration adapter screws over the head of sensor. Then calibration gas is fed through a tube connected onto the adapter.

Most Sierra Monitor gas sensor modules are equipped with a magnetic switch to signal the sensor module that calibration is being performed. The magnetic calibration adapter is used to control this switch. When the adapter is attached to the sensor the switch closes to indicate the start of calibration. The sensor module will then hold the present output until the magnetic calibration adapter is removed signaling completion of calibration.

There are two calibration adapters available, the 5358-00 Magnetic Calibration Adapter and the 5358-01 Standard (non-magnetic) Calibration Adapter. The magnetic adapters are needed when the user needs to hold the current value during calibration to avoid nuisance alarms and the standard (non-magnetic) adapter if necessary during global calibration.

