

FITOK

Full Technical Catalog for
Ultra High Purity Products

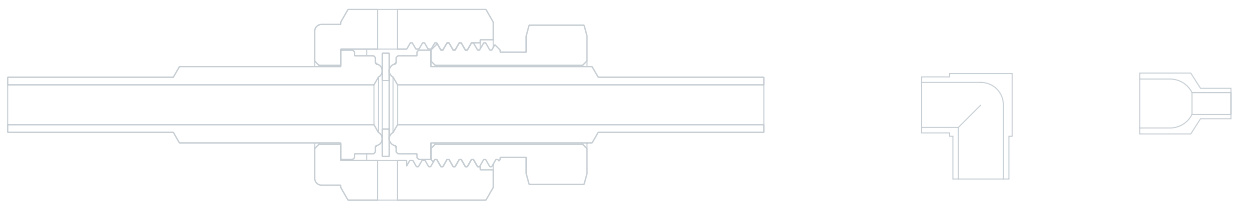

FITOK Full Technical Catalog
For Ultra High Purity Products

Weld Fittings



Face Seal Fittings



Diaphragm Valves



Bellows-sealed Valves



Check Valves



Regulators



Fittings

Weld Fittings	F-01
M Series Micro Weld Fittings	F-03
L Series Tube Butt Weld Fittings	F-08
A Series Automatic Tube Butt Weld Fittings	F-11
T Series Tubular Fittings	F-15
Face Seal Fittings	F-18
FR Series Metal Gasket Face Seal Fittings	F-20
TFO Series L-ring Face Seal Fittings	F-38
FO Series O-ring Face Seal Fittings	F-42

V valves & Regulators

Diaphragm Valves	V-01
DQ Series Low Pressure Manual Diaphragm Valves	V-02
DP Series Low Pressure Pneumatic Diaphragm Valves	V-10
DH Series High Pressure Springless Diaphragm Valves	V-19
DM Series High Pressure Spring Diaphragm Valves	V-24
DS Series High Pressure Compact Diaphragm Valves	V-31
DR Series Low Pressure/Medium Flow Diaphragm Valves	V-36
DV Series Low Pressure/High Flow Diaphragm Valves	V-41
DL Series Low Pressure/Ultra High Flow Diaphragm Valves	V-48
DF Series High Pressure/High Flow Diaphragm Valves	V-53
Bellows-sealed Valves	V-57
SM Series Low Pressure Bellows-sealed Valves	V-58
SVH Series High Pressure Bellows-sealed Valves	V-64
Check Valves	V-70
SW Series All-Welded Check Valves	V-70
Regulators	V-72
FHR-1 Series High Performance High Purity Regulators	V-72

Weld Fittings

M Series



L Series



A Series



T Series



Weld Fittings

Features

- ⦿ Radius junction design with elbows to provide smooth flow path
- ⦿ Precision machined diameter to match tube diameter
- ⦿ Square, burr-free tube weld ends to enhance alignment
- ⦿ Manual or automatic welding equipment both applicable
- ⦿ Tube wall uniformity to promote weld repeatability
- ⦿ Standard surface roughness finished to an average of Ra 10 µin. (0.25 µm) or electropolished to Ra 5 µin. (0.13 µm) optional
- ⦿ Each fitting marked with size, material and heat number

Technical Data

- ⦿ Materials:

Material	Bar Stock ^①	Forging ^②	Designator
316 SS	ASTM A479/A276	ASTM A182/A314	SS
316L SS			6L
316L VAR SS	ASTM A479/A276 SEMI F20	—	6LV
316L VIM-VAR SS			6LW

① Only for straight configurations and all M Series weld fittings.

② Includes all elbows, crosses and tees, excluding M Series weld fittings.

- ⦿ Working Pressure:
 - a. Working pressures shown in the Catalog are calculated according to ASME B31.3 and B31.1 at ambient temperature.
 - b. To get the allowable working pressure at elevated temperature, use the allowable working pressure at ambient temperature to multiply the elevated temperature factors. Please refer to Table 22 - Elevated Temperature Factors in the FITOK Catalog **Tubing** for the elevated temperature factors.

- ⦿ Working Temperature:

Material	Minimum Temperature	Maximum Temperature
316 SS	-325°F (-198°C)	1000°F (538°C)
316L SS	-325°F (-198°C)	850°F (454°C)
316L VAR SS		
316L VIM-VAR SS		

Ordering Information

- ⦿ Add the material designator as a prefix, cleaning and packaging code as a suffix to the basic ordering number to get the complete ordering number.
- ⦿ Cleaning and Packaging
 - a. FC-01 Standard Cleaning and Packaging is applied for general industrial procedures. No suffix is needed.
 - b. FC-02 Special Cleaning and Packaging, to ensure compliance with product cleanliness requirement as stated in ASTM G93 Level C. Add "-F2" as a suffix when needed.
 - c. FC-03 Ultra-High Purity Process Specification is applied to products with wetted surface roughness finished to an average of Ra 5 µin. (0.13 µm). Add "-F3" as suffix when needed.

Example: For 1/2" 316L VAR SS Union Tee with FC-03 Ultra-High Purity Process Specification, the ordering number is 6LV-WT1-TB8-F3.

Cautions

- ⦿ Dimensions are for reference only and are subject to change.
- ⦿ Welding of the same material is more advisable considering the same coefficient of expansion, lower possibility of poor weld, out-of-roundness or dimensional changes.
- ⦿ Tungsten Inert Gas Welding (TIG) is recommended.

M Series Micro Weld Fittings

Features

- Compact design
- Sizes range from 1/8" to 1/2" and 6 mm to 12 mm
- Applicable to miniaturized tubing system



Reducing Unions

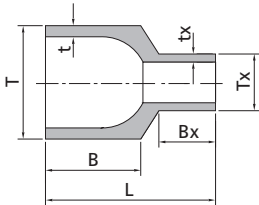

T-Tube O.D. (in.)	t-Wall Thickness (in.)	Tx-Tube O.D. (in.)	tx-Wall Thickness (in.)	Basic Ordering Number	Dimensions, in. (mm)			Working Pressure psig (bar)
					L	B	Bx	
1/4	0.035	1/8	0.028	-WU1-TB4-TB2	0.75 (19.1)	0.42 (10.7)	0.25 (6.4)	5100 (351)
3/8	0.035	1/4	0.035	-WU1-TB6-TB4	0.75 (19.1)	0.42 (10.7)	0.25 (6.4)	3300 (227)
1/2	0.049	1/4	0.035	-WU1-TB8-TB4	0.75 (19.1)	0.42 (10.7)	0.25 (6.4)	3700 (254)
1/2	0.049	3/8	0.035	-WU1-TB8-TB6	0.75 (19.1)	0.42 (10.7)	0.25 (6.4)	3300 (227)

90° Union Elbows

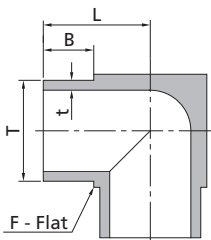

T-Tube O.D. (in.)	t-Wall Thickness (in.)	Basic Ordering Number	Dimensions, in. (mm)			Working Pressure psig (bar)
			L	B	F	
1/8	0.028	-WL1-TB2	0.41 (10.4)	0.25 (6.4)	5/16 (7.9)	8500 (585)
1/4	0.035	-WL1-TB4	0.41 (10.4)	0.25 (6.4)	5/16 (7.9)	5100 (351)
3/8	0.035	-WL1-TB6	0.47 (11.9)	0.25 (6.4)	7/16 (11.1)	3300 (227)
1/2	0.049	-WL1-TB8	0.53 (13.5)	0.25 (6.4)	9/16 (14.3)	3700 (254)

T-Tube O.D. (mm)	t-Wall Thickness (mm)	Basic Ordering Number	Dimensions, mm (in.)			Working Pressure bar (psig)
			L	B	F	
6	1.0	-WL1-MTB6	10.4 (0.41)	6.4 (0.25)	7.9 (5/16)	420 (6095)
8	1.0	-WL1-MTB8	11.9 (0.47)	6.4 (0.25)	11.1 (7/16)	310 (4499)
10	1.0	-WL1-MTB10	11.9 (0.47)	6.4 (0.25)	11.1 (7/16)	240 (3483)
12	1.0	-WL1-MTB12	13.5 (0.53)	6.4 (0.25)	14.3 (9/16)	200 (2902)

Extended Leg 90° Union Elbows

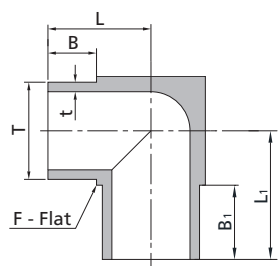

T-Tube O.D. (in.)	t-Wall Thickness (in.)	Basic Ordering Number	Dimensions, in. (mm)					Working Pressure psig (bar)
			B	B1	F	L	L1	
1/4	0.035	-WL1-TB4-1	0.25 (6.4)	0.45 (11.4)	5/16 (7.9)	0.41 (10.4)	0.61 (15.5)	5100 (351)
1/4	0.035	-WL1-TB4-2	0.25 (6.4)	0.50 (12.7)	5/16 (7.9)	0.41 (10.4)	0.66 (16.8)	5100 (351)
1/4	0.035	-WL1-TB4-3	0.45 (11.4)	0.45 (11.4)	5/16 (7.9)	0.61 (15.5)	0.61 (15.5)	5100 (351)
1/4	0.035	-WL1-TB4-4	0.50 (12.7)	0.50 (12.7)	5/16 (7.9)	0.66 (16.8)	0.66 (16.8)	5100 (351)

Reducing 90° Union Elbows

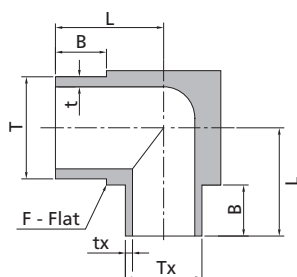

T-Tube O.D. (in.)	t-Wall Thickness (in.)	Tx-Tube O.D. (in.)	tx-Wall Thickness (in.)	Basic Ordering Number	Dimensions, in. (mm)			Working Pressure psig (bar)
					L	B	F	
3/8	0.035	1/4	0.035	-WL1-TB6-TB4	0.47 (11.9)	0.25 (6.4)	7/16 (11.1)	3300 (227)
1/2	0.049	1/4	0.035	-WL1-TB8-TB4	0.53 (13.5)	0.25 (6.4)	9/16 (14.3)	3700 (254)
1/2	0.049	3/8	0.035	-WL1-TB8-TB6	0.53 (13.5)	0.25 (6.4)	9/16 (14.3)	3300 (227)

T-Tube O.D. (mm)	t-Wall Thickness (mm)	Tx-Tube O.D. (mm)	tx-Wall Thickness (mm)	Basic Ordering Number	Dimensions, mm (in.)			Working Pressure bar (psig)
					L	B	F	
8	1.0	6	1.0	-WL1-MTB8-MTB6	11.9 (0.47)	6.4 (0.25)	11.1 (7/16)	310 (4499)
10	1.0	6	1.0	-WL1-MTB10-MTB6	11.9 (0.47)	6.4 (0.25)	11.1 (7/16)	240 (3483)
12	1.0	6	1.0	-WL1-MTB12-MTB6	13.5 (0.53)	6.4 (0.25)	14.3 (9/16)	200 (2902)
12	1.0	8	1.0	-WL1-MTB12-MTB8	13.5 (0.53)	6.4 (0.25)	14.3 (9/16)	200 (2902)

45° Union Elbows

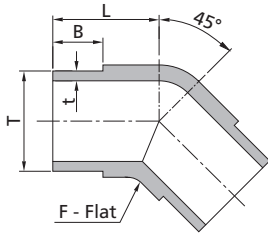

T-Tube O.D. (in.)	t-Wall Thickness (in.)	Basic Ordering Number	Dimensions, in. (mm)			Working Pressure psig (bar)
			L	B	F	
1/4	0.035	-WV1-TB4	0.41 (10.4)	0.25 (6.4)	5/16 (7.9)	5100 (351)
3/8	0.035	-WV1-TB6	0.47 (11.9)	0.25 (6.4)	7/16 (11.1)	3300 (227)
1/2	0.049	-WV1-TB8	0.53 (13.5)	0.25 (6.4)	9/16 (14.3)	3700 (254)

Tribows

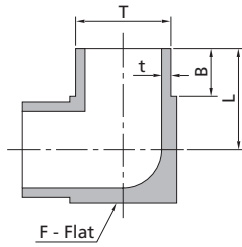

T-Tube O.D. (in.)	t-Wall Thickness (in.)	Basic Ordering Number	Dimensions, in. (mm)			Working Pressure psig (bar)
			L	B	F	
1/4	0.035	-WB1-TB4	0.41 (10.4)	0.25 (6.4)	5/16 (7.9)	5100 (351)
3/8	0.035	-WB1-TB6	0.47 (11.9)	0.25 (6.4)	7/16 (11.1)	3300 (227)
1/2	0.049	-WB1-TB8	0.53 (13.5)	0.25 (6.4)	9/16 (14.3)	3700 (254)



T-Tube O.D. (mm)	t-Wall Thickness (mm)	Basic Ordering Number	Dimensions, mm (in.)			Working Pressure bar (psig)
			L	B	F	
6	1.0	-WB1-MTB6	10.4 (0.41)	6.4 (0.25)	7.9 (5/16)	420 (6095)

Union Tees

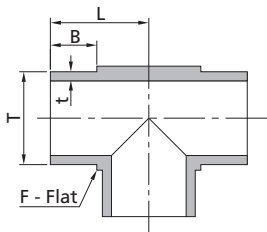

T-Tube O.D. (in.)	t-Wall Thickness (in.)	Basic Ordering Number	Dimensions, in. (mm)			Working pressure psig (bar)
			L	B	F	
1/8	0.028	-WT1-TB2	0.41 (10.4)	0.25 (6.4)	5/16 (7.9)	8500 (585)
1/4	0.035	-WT1-TB4	0.41 (10.4)	0.25 (6.4)	5/16 (7.9)	5100 (351)
3/8	0.035	-WT1-TB6	0.47 (11.9)	0.25 (6.4)	7/16 (11.1)	3300 (227)
1/2	0.049	-WT1-TB8	0.53 (13.5)	0.25 (6.4)	9/16 (14.3)	3700 (254)

T-Tube O.D. (mm)	t-Wall Thickness (mm)	Basic Ordering Number	Dimensions, mm (in.)			Working pressure bar (psig)
			L	B	F	
6	1.0	-WT1-MTB6	10.4 (0.41)	6.4 (0.25)	7.9 (5/16)	420 (6095)
8	1.0	-WT1-MTB8	11.9 (0.47)	6.4 (0.25)	11.1 (7/16)	310 (4499)
10	1.0	-WT1-MTB10	11.9 (0.47)	6.4 (0.25)	11.1 (7/16)	240 (3483)
12	1.0	-WT1-MTB12	13.5 (0.53)	6.4 (0.25)	14.3 (9/16)	200 (2902)

Extended Branch Leg Union Tees

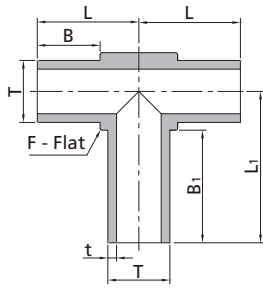

T-Tube O.D. (in.)	t-Wall Thickness (in.)	Basic Ordering Number	Dimensions, in. (mm)					Working Pressure psig (bar)
			L	L ₁	B	B ₁	F	
1/4	0.035	-WT1-TB4-45	0.41 (10.4)	0.61 (15.5)	0.25 (6.4)	0.45 (11.4)	5/16 (7.9)	5100 (351)

Extended Run Leg Union Tees

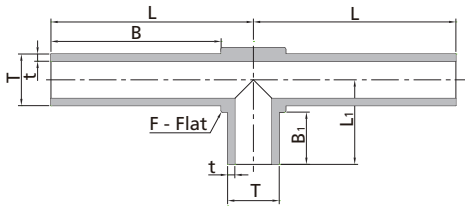

There may be a minor step between run ends at drill intersection.

T-Tube O.D. (in.)	t-Wall Thickness (in.)	Basic Ordering Number	Dimensions, in. (mm)					Working Pressure psig (bar)
			L	L ₁	B	B ₁	F	
1/4	0.035	-WT1-TB4-98	0.98 (24.9)	0.41 (10.4)	0.83 (21.1)	0.25 (6.4)	5/16 (7.9)	5100 (351)

Reducing Tees

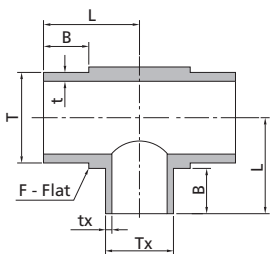

T-Tube O.D. (in.)	t-Wall Thickness (in.)	Tx-Tube O.D. (in.)	tx-Wall Thickness (in.)	Basic Ordering Number	Dimensions, in. (mm)			Working Pressure psig (bar)
					L	B	F	
3/8	0.035	1/4	0.035	-WT1-TB6-TB6-TB4	0.47 (11.9)	0.25 (6.4)	7/16 (11.1)	3300 (227)
1/2	0.049	1/4	0.035	-WT1-TB8-TB8-TB4	0.53 (13.5)	0.25 (6.4)	9/16 (14.3)	3700 (254)
1/2	0.049	3/8	0.035	-WT1-TB8-TB8-TB6	0.53 (13.5)	0.25 (6.4)	9/16 (14.3)	3300 (227)

F-07 Weld Fittings

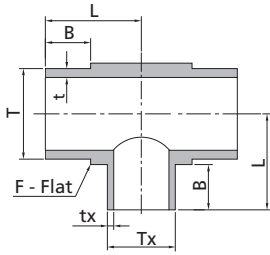

T-Tube O.D. (mm)	t-Wall Thickness (mm)	Tx-Tube O.D. (mm)	tx-Wall Thickness (mm)	Basic Ordering Number	Dimensions, mm (in.)			Working Pressure bar (psig)
					L	B	F	
10	1.0	6	1.0	-WT1-MTB10-MTB10-MTB6	11.9 (0.47)	6.4 (0.25)	11.1 (7/16)	240 (3483)
12	1.0	6	1.0	-WT1-MTB12-MTB12-MTB6	0.53 (13.5)	6.4 (0.25)	14.3 (9/16)	200 (2902)
12	1.0	8	1.0	-WT1-MTB12-MTB12-MTB8	0.53 (13.5)	6.4 (0.25)	14.3 (9/16)	200 (2902)

Union Crosses

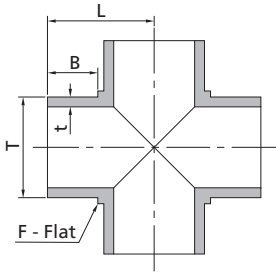

T-Tube O.D. (in.)	t-Wall Thickness (in.)	Basic Ordering Number	Dimensions, in. (mm)			Working Pressure psig (bar)
			L	B	F	
1/8	0.028	-WC1-TB2	0.41 (10.4)	0.25 (6.4)	5/16 (7.9)	8500 (585)
1/4	0.035	-WC1-TB4	0.41 (10.4)	0.25 (6.4)	5/16 (7.9)	5100 (351)
3/8	0.035	-WC1-TB6	0.47 (11.9)	0.25 (6.4)	7/16 (11.1)	3300 (227)
1/2	0.049	-WC1-TB8	0.53 (13.5)	0.25 (6.4)	9/16 (14.3)	3700 (254)

T-Tube O.D. (mm)	t-Wall Thickness (mm)	Basic Ordering Number	Dimensions, mm (in.)			Working Pressure bar (psig)
			L	B	F	
6	1.0	-WC1-MTB6	10.4 (0.41)	6.4 (0.25)	7.9 (5/16)	420 (6095)
8	1.0	-WC1-MTB8	11.9 (0.47)	6.4 (0.25)	11.1 (7/16)	310 (4499)
10	1.0	-WC1-MTB10	11.9 (0.47)	6.4 (0.25)	11.1 (7/16)	240 (3483)
12	1.0	-WC1-MTB12	13.5 (0.53)	6.4 (0.25)	14.3 (9/16)	200 (2902)

L Series Tube Butt Weld Fittings

Features

- Extended tube design
- Machined from forging blanks except for straight configurations
- Sizes range from 1/4" to 1" and 6 mm to 18 mm



Reducing Unions

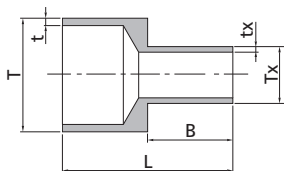

T-Tube O.D. (in.)	t-Wall Thickness (in.)	Tx-Tube O.D. (in.)	tx-Wall Thickness (in.)	Basic Ordering Number	Dimensions, in. (mm)		Working Pressure psig (bar)
					L	B	
3/8	0.035	1/4	0.035	-WU2-TB6-TB4	1.50 (38.1)	0.75 (19.1)	3300 (227)
1/2	0.049	1/4	0.035	-WU2-TB8-TB4	1.50 (38.1)	0.75 (19.1)	3700 (254)
1/2	0.049	3/8	0.035	-WU2-TB8-TB6	1.50 (38.1)	0.75 (19.1)	3300 (227)
3/4	0.049	1/2	0.049	-WU2-TB12-TB8	1.50 (38.1)	0.75 (19.1)	2400 (165)
1	0.065	1/2	0.049	-WU2-TB16-TB8	1.50 (38.1)	0.75 (19.1)	2400 (165)
1	0.065	3/4	0.049	-WU2-TB16-TB12	1.50 (38.1)	0.75 (19.1)	2400 (165)

T-Tube O.D. (mm)	t-Wall Thickness (mm)	Tx-Tube O.D. (mm)	tx-Wall Thickness (mm)	Basic Ordering Number	Dimensions, mm (in.)		Working Pressure bar (psig)
					L	B	
10	1.0	6	1.0	-WU2-MTB10-MTB6	38.1 (1.50)	19.1 (0.75)	240 (3483)
10	1.0	8	1.0	-WU2-MTB10-MTB8	38.1 (1.50)	19.1 (0.75)	240 (3483)
12	1.0	6	1.0	-WU2-MTB12-MTB6	38.1 (1.50)	19.1 (0.75)	200 (2902)
12	1.0	8	1.0	-WU2-MTB12-MTB8	38.1 (1.50)	19.1 (0.75)	200 (2902)
12	1.0	10	1.0	-WU2-MTB12-MTB10	38.1 (1.50)	19.1 (0.75)	200 (2902)
18	1.5	6	1.5	-WU2-MTB18-MTB6	38.1 (1.50)	19.1 (0.75)	200 (2902)
18	1.5	12	1.5	-WU2-MTB18-MTB12	38.1 (1.50)	19.1 (0.75)	200 (2902)

Union Elbows

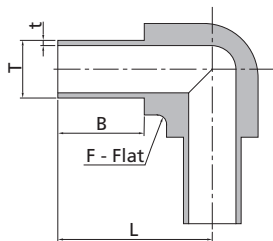

T-Tube O.D. (in.)	t-Wall Thickness (in.)	Basic Ordering Number	Dimensions, in. (mm)			Working Pressure psig (bar)
			L	B	F	
1/4	0.035	-WL2-TB4	1.23 (31.2)	0.75 (19.1)	7/16 (11.1)	5100 (351)
3/8	0.035	-WL2-TB6	1.20 (30.5)	0.75 (19.1)	7/16 (11.1)	3300 (227)
1/2	0.049	-WL2-TB8	1.34 (34.0)	0.75 (19.1)	11/16 (17.5)	3700 (254)
3/4	0.049	-WL2-TB12	1.46 (37.1)	0.75 (19.1)	15/16 (23.8)	2400 (165)

T-Tube O.D. (mm)	t-Wall Thickness (mm)	Basic Ordering Number	Dimensions, mm (in.)			Working Pressure bar (psig)
			L	B	F	
6	1.0	-WL2-MTB6	31.2 (1.23)	19.1 (0.75)	11.1 (7/16)	420 (6095)
8	1.0	-WL2-MTB8	31.2 (1.23)	19.1 (0.75)	11.1 (7/16)	310 (4499)
10	1.0	-WL2-MTB10	34.0 (1.34)	19.1 (0.75)	17.5 (11/16)	240 (3483)
12	1.0	-WL2-MTB12	34.0 (1.34)	19.1 (0.75)	17.5 (11/16)	200 (2902)
18	1.5	-WL2-MTB18	37.6 (1.48)	19.1 (0.75)	23.8 (15/16)	200 (2902)

Union Tees

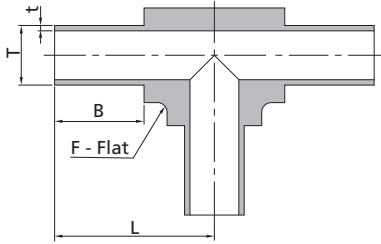

T-Tube O.D. (in.)	t-Wall Thickness (in.)	Basic Ordering Number	Dimensions, in. (mm)			Working Pressure psig (bar)
			L	B	F	
1/4	0.035	-WT2-TB4	1.23 (31.2)	0.75 (19.1)	7/16 (11.1)	5100 (351)
3/8	0.035	-WT2-TB6	1.20 (30.5)	0.75 (19.1)	7/16 (11.1)	3300 (227)
1/2	0.049	-WT2-TB8	1.34 (34.0)	0.75 (19.1)	11/16 (17.5)	3700 (254)
3/4	0.049	-WT2-TB12	1.46 (37.1)	0.75 (19.1)	15/16 (23.8)	2400 (165)

T-Tube O.D. (mm)	t-Wall Thickness (mm)	Basic Ordering Number	Dimensions, mm (in.)			Working Pressure bar (psig)
			L	B	F	
6	1.0	-WT2-MTB6	31.2 (1.23)	19.1 (0.75)	11.1 (7/16)	420 (6095)
8	1.0	-WT2-MTB8	31.2 (1.23)	19.1 (0.75)	11.1 (7/16)	310 (4499)
10	1.0	-WT2-MTB10	34.0 (1.34)	19.1 (0.75)	17.5 (11/16)	240 (3483)
12	1.0	-WT2-MTB12	34.0 (1.34)	19.1 (0.75)	17.5 (11/16)	200 (2902)
18	1.5	-WT2-MTB18	37.6 (1.48)	19.1 (0.75)	23.8 (15/16)	200 (2902)

Reducing Tees

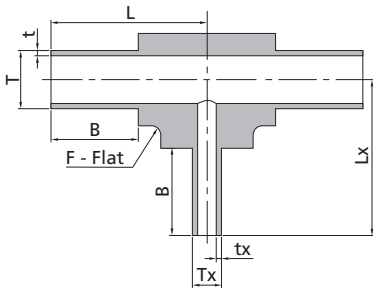

T-Tube O.D. (in.)	t-Wall Thickness (in.)	Tx-Tube O.D. (in.)	tx-Wall Thickness (in.)	Basic Ordering Number	Dimensions, in. (mm)				Working Pressure psig (bar)
					L	Lx	B	F	
3/8	0.035	1/4	0.035	-WT2-TB6-TB6-TB4	1.20 (30.5)	1.23 (31.2)	0.75 (19.1)	7/16 (11.1)	3300 (227)
1/2	0.049	1/4	0.035	-WT2-TB8-TB8-TB4	1.34 (34.0)	1.34 (34.0)	0.75 (19.1)	11/16 (17.5)	3700 (254)
1/2	0.049	3/8	0.035	-WT2-TB8-TB8-TB6	1.34 (34.0)	1.35 (34.3)	0.75 (19.1)	11/16 (17.5)	3700 (254)
3/4	0.049	1/4	0.035	-WT2-TB12-TB12-TB4	1.46 (37.1)	1.48 (37.6)	0.75 (19.1)	15/16 (23.8)	2400 (165)
3/4	0.049	3/8	0.035	-WT2-TB12-TB12-TB6	1.46 (37.1)	1.35 (34.3)	0.75 (19.1)	15/16 (23.8)	2400 (165)

T-Tube O.D. (mm)	t-Wall Thickness (mm)	Tx-Tube O.D. (mm)	tx-Wall Thickness (mm)	Basic Ordering Number	Dimensions, mm (in.)				Working Pressure bar (psig)
					L	Lx	B	F	
8	1.0	6	1.0	-WT2-MTB8-MTB8-MTB6	31.3 (1.23)	31.3 (1.23)	19.1 (0.75)	11.1 (7/16)	310 (4499)
10	1.0	6	1.0	-WT2-MTB10-MTB10-MTB6	34.0 (1.34)	34.0 (1.34)	19.1 (0.75)	17.5 (11/16)	240 (3483)
10	1.0	8	1.0	-WT2-MTB10-MTB10-MTB8	34.0 (1.34)	34.0 (1.34)	19.1 (0.75)	17.5 (11/16)	240 (3483)
12	1.0	6	1.0	-WT2-MTB12-MTB12-MTB6	34.0 (1.34)	34.0 (1.34)	19.1 (0.75)	17.5 (11/16)	200 (2902)
12	1.0	8	1.0	-WT2-MTB12-MTB12-MTB8	34.0 (1.34)	34.0 (1.34)	19.1 (0.75)	17.5 (11/16)	200 (2902)

Union Crosses

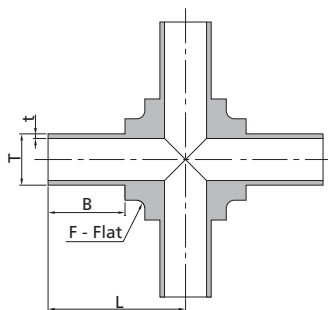

T-Tube O.D. (in.)	t-Wall Thickness (in.)	Basic Ordering Number	Dimensions, in. (mm)			Working Pressure psig (bar)
			L	B	F	
1/4	0.035	-WC2-TB4	1.23 (31.2)	0.75 (19.1)	7/16 (11.1)	5100 (351)
3/8	0.035	-WC2-TB6	1.20 (30.5)	0.75 (19.1)	7/16 (11.1)	3300 (227)
1/2	0.049	-WC2-TB8	1.34 (34.0)	0.75 (19.1)	11/16 (17.5)	3700 (254)

T-Tube O.D. (mm)	t-Wall Thickness (mm)	Basic Ordering Number	Dimensions, mm (in.)			Working Pressure bar (psig)
			L	B	F	
6	1.0	-WC2-MTB6	31.2 (1.23)	19.1 (0.75)	11.1 (7/16)	420 (6095)
8	1.0	-WC2-MTB8	31.2 (1.23)	19.1 (0.75)	11.1 (7/16)	310 (4499)
10	1.0	-WC2-MTB10	34.0 (1.34)	19.1 (0.75)	15.9 (5/8)	240 (3483)
12	1.0	-WC2-MTB12	34.0 (1.34)	19.1 (0.75)	15.9 (5/8)	200 (2902)

Weld Rings

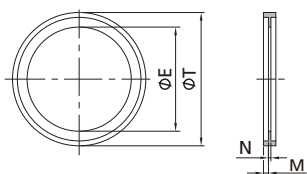

T-Tube O.D. (in.)	Basic Ordering Number	Dimensions, in. (mm)			
		E	M	N	T
1/4	-WR-4	0.20 (5.1)	0.02 (0.51)	0.01 (0.25)	0.28 (7.1)
3/8	-WR-6	0.32 (8.1)	0.02 (0.51)	0.01 (0.25)	0.41 (10.4)
1/2	-WR-8	0.42 (10.7)	0.02 (0.51)	0.01 (0.25)	0.54 (13.7)

A Series Automatic Tube Butt Weld Fittings

Features

- Extended tube design with locating ring
- Machined from forging blanks except for straight configurations
- Sizes range from 1/4" to 1" and 6 mm to 18 mm



Locator Unions

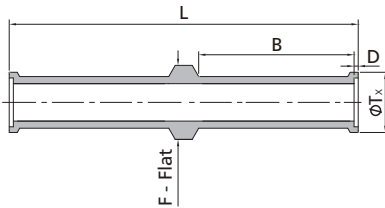

Tube O.D. (in.)	Wall Thickness (in.)	Basic Ordering Number	Dimensions, in. (mm)					Working Pressure psig (bar)
			L	B	D	F	T _x	
1/4	0.035	-WU2-L-TB4A	1.69 (42.9)	0.75 (19.1)	0.02 (0.5)	0.36 (9.1)	0.29 (7.4)	5100 (351)
3/8	0.035	-WU2-L-TB6A	1.71 (43.4)	0.75 (19.1)	0.03 (0.8)	0.42 (10.7)	0.41 (10.4)	3300 (227)
1/2	0.049	-WU2-L-TB8A	1.73 (43.9)	0.75 (19.1)	0.04 (1.0)	0.60 (15.2)	0.55 (14.0)	3700 (254)

Unions

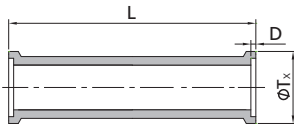

Tube O.D. (in.)	Wall Thickness (in.)	Basic Ordering Number	Dimensions, in. (mm)			Working Pressure psig (bar)
			L	D	T _x	
1/4	0.035	-WU2-TB4A	1.00 (25.4)	0.02 (0.5)	0.29 (7.4)	5100 (351)
3/8	0.035	-WU2-TB6A	1.00 (25.4)	0.03 (0.8)	0.41 (10.4)	3300 (227)
1/2	0.049	-WU2-TB8A	1.00 (25.4)	0.04 (1.0)	0.55 (14.0)	3700 (254)
3/4	0.049	-WU2-TB12A	1.00 (25.4)	0.04 (1.0)	0.80 (20.3)	2400 (165)
1	0.065	-WU2-TB16A	1.25 (31.8)	0.04 (1.0)	1.06 (26.9)	2400 (165)

Tube O.D. (in.)	Wall Thickness (in.)	Basic Ordering Number	Dimensions, mm (in.)			Working Pressure bar (psig)
			L	D	T _x	
6	1	-WU2-MTB6A	31.8 (1.25)	0.5 (0.02)	6.9 (0.27)	420 (6095)
8	1	-WU2-MTB8A	31.8 (1.25)	0.8 (0.03)	8.9 (0.35)	310 (4499)
10	1	-WU2-MTB10A	31.8 (1.25)	0.8 (0.03)	10.9 (0.43)	240 (3483)
12	1	-WU2-MTB12A	31.8 (1.25)	1.0 (0.04)	13.2 (0.52)	200 (2902)
18	1.5	-WU2-MTB18A	31.8 (1.25)	1.0 (0.04)	19.3 (0.76)	200 (2902)

Reducing Unions

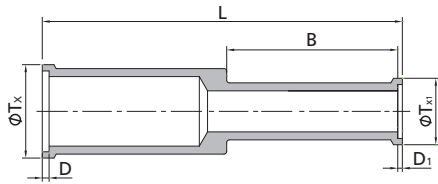

Tube O.D. (in.)	Wall Thickness (in.)	Tube O.D. (in.)	Wall Thickness (in.)	Basic Ordering Number	Dimensions, in. (mm)						Working Pressure psig (bar)
					L	B	D	D ₁	T _x	T _{x1}	
3/8	0.035	1/4	0.035	-WU2-TB6A-TB4A	1.58 (40.1)	0.75 (19.1)	0.03 (0.8)	0.02 (0.5)	0.41 (10.4)	0.29 (7.4)	3300 (227)
1/2	0.049	1/4	0.035	-WU2-TB8A-TB4A	1.58 (40.1)	0.75 (19.1)	0.04 (1.0)	0.02 (0.5)	0.55 (14.0)	0.29 (7.4)	3700 (254)
1/2	0.049	3/8	0.035	-WU2-TB8A-TB6A	1.58 (40.1)	0.75 (19.1)	0.04 (1.0)	0.03 (0.8)	0.55 (14.0)	0.41 (10.4)	3300 (227)
3/4	0.049	1/2	0.049	-WU2-TB12A-TB8A	1.62 (41.1)	0.75 (19.1)	0.04 (1.0)	0.04 (1.0)	0.80 (20.3)	0.55 (14.0)	2400 (165)

Tube O.D. (mm)	Wall Thickness (mm)	Tube O.D. (mm)	Wall Thickness (mm)	Basic Ordering Number	Dimensions, mm (in.)						Working Pressure bar (psig)
					L	B	D	D ₁	T _x	T _{x1}	
8	1	6	1	-WU2-MTB8A-MTB6A	39.9 (1.57)	19.1 (0.75)	0.8 (0.03)	0.5 (0.02)	8.90 (0.35)	6.8 (0.27)	310 (4499)
12	1	6	1	-WU2-MTB12A-MTB6A	40.1 (1.58)	19.1 (0.75)	1.0 (0.04)	0.5 (0.02)	13.2 (0.52)	6.8 (0.27)	200 (2902)
12	1	8	1	-WU2-MTB12A-MTB8A	40.4 (1.59)	19.1 (0.75)	1.0 (0.04)	0.8 (0.03)	13.2 (0.52)	8.9 (0.35)	200 (2902)

90° Union Elbows

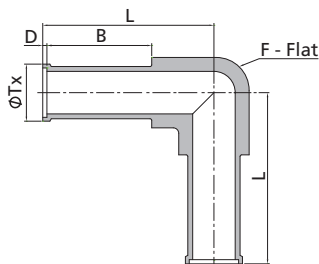

Tube O.D. (in.)	Wall Thickness (in.)	Basic Ordering Number	Dimensions, in. (mm)					Working Pressure psig (bar)
			L	B	D	F	T _x	
1/4	0.035	-WL2-TB4A	1.25 (31.8)	0.75 (19.1)	0.02 (0.5)	7/16 (11.1)	0.29 (7.4)	5100 (351)
3/8	0.035	-WL2-TB6A	1.23 (31.2)	0.75 (19.1)	0.03 (0.8)	7/16 (11.1)	0.41 (10.4)	3300 (227)
1/2	0.049	-WL2-TB8A	1.38 (35.1)	0.75 (19.1)	0.04 (1.0)	11/16 (17.5)	0.55 (14.0)	3700 (254)
3/4	0.049	-WL2-TB12A	1.50 (38.1)	0.75 (19.1)	0.04 (1.0)	15/16 (23.8)	0.80 (20.3)	2400 (165)

Tube O.D. (mm)	Wall Thickness (mm)	Basic Ordering Number	Dimensions, mm (in.)					Working Pressure bar (psig)
			L	B	D	F	T _x	
6	1	-WL2-MTB6A	31.8 (1.25)	19.1 (0.75)	0.5 (0.02)	11.1 (7/16)	6.90 (0.27)	351 (5100)
8	1	-WL2-MTB8A	32.0 (1.26)	19.1 (0.75)	0.8 (0.03)	11.1 (7/16)	8.90 (0.35)	227 (3300)
10	1	-WL2-MTB10A	34.8 (1.37)	19.1 (0.75)	0.8 (0.03)	17.5 (11/16)	10.9 (0.43)	254 (3700)
12	1	-WL2-MTB12A	35.1 (1.38)	19.1 (0.75)	1.0 (0.04)	17.5 (11/16)	13.2 (0.52)	199 (2888)
18	1.5	-WL2-MTB18A	38.6 (1.52)	19.1 (0.75)	1.0 (0.04)	23.8 (15/16)	19.3 (0.76)	206 (2989)

Union Tees

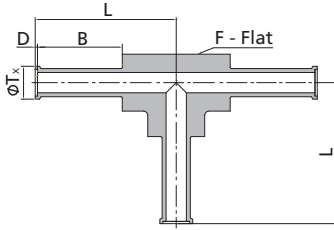

Tube O.D. (in.)	Wall Thickness (in.)	Basic Ordering Number	Dimensions, in. (mm)					Working Pressure psig (bar)
			L	B	D	F	T _x	
1/4	0.035	-WT2-TB4A	1.25 (31.8)	0.75 (19.1)	0.02 (0.5)	7/16 (11.1)	0.29 (7.4)	5100 (351)
3/8	0.035	-WT2-TB6A	1.23 (31.2)	0.75 (19.1)	0.03 (0.8)	7/16 (11.1)	0.41 (10.4)	3300 (227)
1/2	0.049	-WT2-TB8A	1.38 (35.1)	0.75 (19.1)	0.04 (1.0)	11/16 (17.5)	0.55 (14.0)	3500 (241)
3/4	0.049	-WT2-TB12A	1.50 (38.1)	0.75 (19.1)	0.04 (1.0)	15/16 (23.8)	0.80 (20.3)	2400 (165)

Tube O.D. (mm)	Wall Thickness (mm)	Basic Ordering Number	Dimensions, mm (in.)					Working Pressure bar (psig)
			L	B	D	F	T _x	
6	1	-WT2-MTB6A	31.8 (1.25)	19.1 (0.75)	0.5 (0.02)	11.1 (7/16)	6.90 (0.27)	454 (6589)
8	1	-WT2-MTB8A	32.0 (1.26)	19.1 (0.75)	0.8 (0.03)	11.1 (7/16)	8.90 (0.35)	323 (4687)
10	1	-WT2-MTB10A	34.8 (1.37)	19.1 (0.75)	0.8 (0.03)	17.5 (11/16)	10.9 (0.43)	254 (3686)
12	1	-WT2-MTB12A	35.1 (1.38)	19.1 (0.75)	1.0 (0.04)	17.5 (11/16)	13.2 (0.52)	206 (2989)
18	1.5	-WT2-MTB18A	38.6 (1.52)	19.1 (0.75)	1.0 (0.04)	23.8 (15/16)	19.3 (0.76)	206 (2989)

Reducing Tees

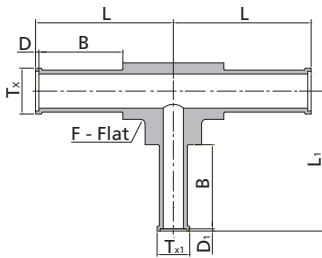

Tube O.D. (in.)	Wall Thickness (in.)	Tube O.D. (in.)	Wall Thickness (in.)	Basic Ordering Number	Dimensions, in. (mm)								Working Pressure psig (bar)
					L	L1	B	D	D1	T _x	T _{x1}	F	
3/8	0.035	1/4	0.035	-WT2-TB6A-TB6A-TB4A	1.23 (31.2)	1.25 (31.8)	0.75 (19.1)	0.03 (0.8)	0.02 (0.5)	0.41 (10.4)	0.29 (7.4)	7/16 (11.1)	3300 (227)
1/2	0.049	1/4	0.035	-WT2-TB8A-TB8A-TB4A	1.38 (35.1)	1.38 (35.1)	0.75 (19.1)	0.04 (1.0)	0.02 (0.5)	0.55 (14.0)	0.29 (7.4)	11/16 (17.5)	3700 (254)
1/2	0.049	3/8	0.035	-WT2-TB8A-TB8A-TB6A	1.38 (35.1)	1.37 (34.8)	0.75 (19.1)	0.04 (1.0)	0.03 (0.8)	0.55 (14.0)	0.41 (10.4)	11/16 (17.5)	3300 (227)
3/4	0.049	3/8	0.035	-WT2-TB12A-TB12A-TB6A	1.50 (38.1)	1.50 (38.1)	0.75 (19.1)	0.04 (1.0)	0.03 (0.8)	0.80 (20.3)	0.41 (10.4)	15/16 (23.8)	2400 (165)
3/4	0.049	1/2	0.049	-WT2-TB12A-TB12A-TB8A	1.50 (38.1)	1.50 (38.1)	0.75 (19.1)	0.04 (1.0)	0.04 (1.0)	0.80 (20.3)	0.55 (14.0)	15/16 (23.8)	2400 (165)

Tube O.D. (mm)	Wall Thickness (mm)	Tube O.D. (mm)	Wall Thickness (mm)	Basic Ordering Number	Dimensions, mm (in.)								Working Pressure bar (psig)
					L	L1	B	D	D1	T _x	T _{x1}	F	
12	1	6	1	-WT2-MTB12A-MTB12A-MTB6A	35.1 (1.38)	34.5 (1.36)	19.1 (0.75)	0.5 (0.02)	0.5 (0.02)	13.2 (0.52)	6.9 (0.27)	17.5 (11/16)	200 (2902)

Manifold Tees

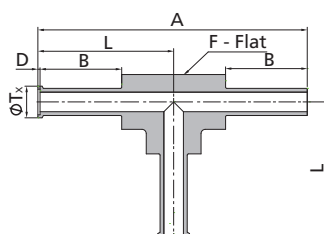

Tube O.D. (in.)	Wall Thickness (in.)	Basic Ordering Number	Dimensions, in. (mm)						Working Pressure psig (bar)
			A	L	B	D	F	T _x	
1/4	0.035	-WT2-TB4A-TB4-TB4A	2.48 (63.0)	1.25 (31.8)	0.75 (19.1)	0.02 (0.5)	7/16 (11.1)	0.29 (7.4)	5100 (351)
3/8	0.035	-WT2-TB6A-TB6-TB6A	2.43 (61.7)	1.23 (31.2)	0.75 (19.1)	0.03 (0.8)	11/16 (17.5)	0.41 (10.4)	3300 (227)
1/2	0.049	-WT2-TB8A-TB8-TB8A	2.72 (69.1)	1.38 (35.1)	0.75 (19.1)	0.04 (1.0)	11/16 (17.5)	0.55 (14.0)	3700 (254)

Reducing Tees

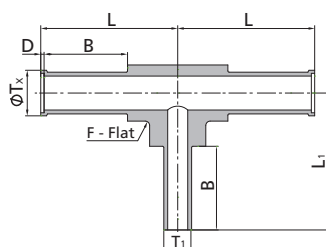

Tube O.D. (in.)	Wall Thickness (in.)	Tube O.D. (in.)	Wall Thickness (in.)	Basic Ordering Number	Dimensions, in. (mm)						Working Pressure psig (bar)
					L	L ₁	B	D	T _x	F	
3/8	0.035	1/4	0.035	-WT2-TB6A-TB6A-TB4	1.23 (31.2)	1.23 (31.2)	0.75 (19.1)	0.03 (0.8)	0.41 (10.4)	7/16 (11.1)	3300 (227)
1/2	0.049	1/4	0.035	-WT2-TB8A-TB8A-TB4	1.38 (35.1)	1.36 (34.5)	0.75 (19.1)	0.04 (1.0)	0.55 (14.0)	11/16 (17.5)	3700 (254)
1/2	0.049	3/8	0.035	-WT2-TB8A-TB8A-TB6	1.38 (35.1)	1.35 (34.3)	0.75 (19.1)	0.04 (1.0)	0.55 (14.0)	11/16 (17.5)	3300 (227)

Union Crosses

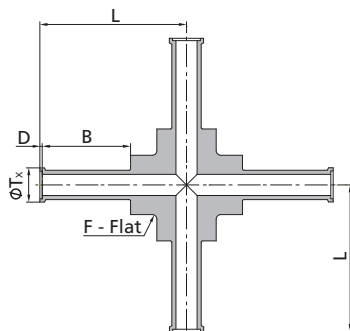

Tube O.D. (in.)	Wall Thickness (in.)	Basic Ordering Number	Dimensions, in. (mm)					Working Pressure psig (bar)
			L	B	D	F	T _x	
1/4	0.035	-WC2-TB4A	1.25 (31.8)	0.75 (19.1)	0.02 (0.5)	7/16 (11.1)	0.29 (7.4)	5100 (351)
3/8	0.035	-WC2-TB6A	1.23 (31.2)	0.75 (19.1)	0.03 (0.8)	7/16 (11.1)	0.41 (10.4)	3300 (227)
1/2	0.049	-WC2-TB8A	1.35 (34.3)	0.75 (19.1)	0.04 (1.0)	5/8 (17.5)	0.55 (14.0)	3700 (254)

Tube O.D. (mm)	Wall Thickness (mm)	Basic Ordering Number	Dimensions, mm (in.)					Working Pressure bar (psig)
			L	B	D	F	T _x	
6	1	-WC2-MTB6A	31.8 (1.25)	19.1 (0.75)	0.5 (0.02)	11.1 (7/16)	6.9 (0.27)	420 (6095)
8	1	-WC2-MTB8A	31.8 (1.25)	19.1 (0.75)	0.8 (0.03)	11.1 (7/16)	8.9 (0.35)	310 (4499)

T Series Tubular Fittings

Features

- 316L Stainless Steel
- Sizes range from 1/4" to 2"
- Available in a variety of configurations



Concentric Reducings

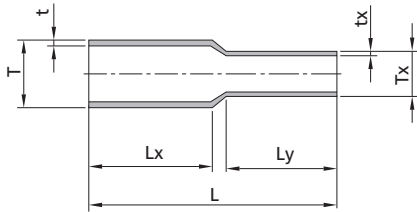

T-Tube O.D. (in.)	t-Wall Thickness (in.)	Tx-Tube O.D. (in.)	tx-Wall Thickness (in.)	Ordering Number	Dimensions, in. (mm)			Working Pressure psig (bar)
					L	Lx	Ly	
3/8	0.035	1/4	0.035	6L-WU3-TB6-TB4	2.75 (69.9)	1.37 (34.8)	1.16 (29.5)	3330 (230)
1/2	0.049	1/4	0.035	6L-WU3-TB8-TB4	2.75 (69.9)	1.37 (34.8)	0.94 (23.9)	3530 (243)
1/2	0.049	3/8	0.035	6L-WU3-TB8-TB6	2.75 (69.9)	1.37 (34.8)	1.16 (29.5)	3330 (230)
3/4	0.065	1/4	0.035	6L-WU3-TB12-TB4	2.75 (69.9)	1.37 (34.8)	1.09 (27.7)	3330 (230)
3/4	0.065	3/8	0.035	6L-WU3-TB12-TB6	2.75 (69.9)	1.37 (34.8)	1.16 (29.5)	3330 (230)
3/4	0.065	1/2	0.049	6L-WU3-TB12-TB8	2.75 (69.9)	1.37 (34.8)	1.23 (31.2)	3330 (230)
1	0.065	1/4	0.035	6L-WU3-TB16-TB4	3.00 (76.2)	1.50 (38.1)	1.07 (27.2)	2420 (167)
1	0.065	3/8	0.035	6L-WU3-TB16-TB6	3.00 (76.2)	1.50 (38.1)	1.14 (29.0)	2420 (167)
1	0.065	1/2	0.049	6L-WU3-TB16-TB8	3.00 (76.2)	1.50 (38.1)	1.21 (30.7)	2420 (167)
1	0.065	3/4	0.065	6L-WU3-TB16-TB12	3.00 (76.2)	1.50 (38.1)	1.35 (34.3)	2420 (167)
1 1/2	0.065	1/4	0.035	6L-WU3-TB24-TB4	5.50 (140.0)	1.50 (38.1)	1.50 (38.1)	1550 (107)
1 1/2	0.065	3/8	0.035	6L-WU3-TB24-TB6	5.50 (140.0)	1.50 (38.1)	1.50 (38.1)	1550 (107)
1 1/2	0.065	1/2	0.049	6L-WU3-TB24-TB8	5.50 (140.0)	1.50 (38.1)	1.50 (38.1)	1550 (107)
1 1/2	0.065	3/4	0.065	6L-WU3-TB24-TB12	5.00 (127.0)	1.50 (38.1)	1.50 (38.1)	1550 (107)
1 1/2	0.065	1	0.065	6L-WU3-TB24-TB16	5.00 (127.0)	1.50 (38.1)	1.50 (38.1)	1160 (80)
2	0.065	1/4	0.035	6L-WU3-TB32-TB4	7.75 (197.0)	1.75 (44.5)	1.50 (38.1)	1160 (80)
2	0.065	3/8	0.035	6L-WU3-TB32-TB6	7.75 (197.0)	1.75 (44.5)	1.50 (38.1)	1160 (80)
2	0.065	1/2	0.049	6L-WU3-TB32-TB8	7.75 (197.0)	1.75 (44.5)	1.50 (38.1)	1160 (80)
2	0.065	3/4	0.065	6L-WU3-TB32-TB12	7.25 (184.0)	1.75 (44.5)	1.50 (38.1)	1160 (80)
2	0.065	1	0.065	6L-WU3-TB32-TB16	7.25 (184.0)	1.75 (44.5)	1.50 (38.1)	1160 (80)
2	0.065	1 1/2	0.065	6L-WU3-TB32-TB24	5.25 (133.0)	1.75 (44.5)	1.50 (38.1)	1160 (80)

90° Elbows

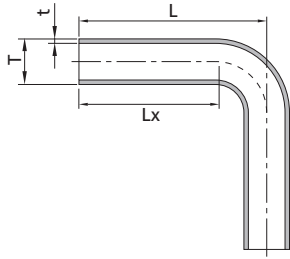

T-Tube O.D. (in.)	t-Wall Thickness (in.)	Ordering Number	Dimensions, in. (mm)		Working Pressure psig (bar)
			L	Lx	
1/4	0.035	6L-WL3-TB4	2.06 (52.3)	1.50 (38.1)	5150 (355)
3/8	0.035	6L-WL3-TB6	2.62 (66.5)	2.06 (52.3)	3330 (230)
1/2	0.049	6L-WL3-TB8	2.62 (66.5)	1.87 (47.5)	3530 (243)
3/4	0.065	6L-WL3-TB12	2.60 (66.0)	1.42 (36.0)	3330 (230)
1	0.065	6L-WL3-TB16	3.00 (76.2)	1.50 (38.1)	2420 (167)
1 1/2	0.065	6L-WL3-TB24	3.75 (95.3)	1.50 (38.1)	1550 (107)
2	0.065	6L-WL3-TB32	4.75 (120.7)	1.75 (44.5)	1160 (80)

45° Elbows

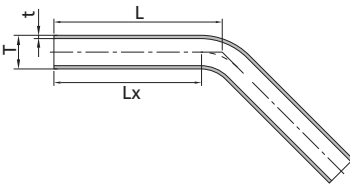

T-Tube O.D. (in.)	t-Wall Thickness (in.)	Ordering Number	Dimensions, in. (mm)		Working Pressure psig (bar)
			L	Lx	
1/4	0.035	6L-WV3-TB4	1.10 (27.9)	0.86 (21.8)	5150 (355)
3/8	0.035	6L-WV3-TB6	2.00 (50.8)	1.76 (44.7)	3330 (230)
1/2	0.049	6L-WV3-TB8	2.50 (63.5)	2.18 (55.4)	3530 (243)
3/4	0.065	6L-WV3-TB12	1.93 (49.0)	1.46 (37.1)	3330 (230)
1	0.065	6L-WV3-TB16	2.25 (57.2)	1.63 (41.4)	2420 (167)
1 1/2	0.065	6L-WV3-TB24	2.50 (63.5)	1.50 (38.1)	1550 (107)
2	0.065	6L-WV3-TB32	3.00 (76.2)	1.75 (44.5)	1160 (80)

Tees

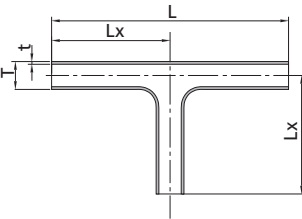

T-Tube O.D. (in.)	t-Wall Thickness (in.)	Ordering Number	Dimensions, in. (mm)		Working Pressure psig (bar)
			L	Lx	
1/4	0.035	6L-WT3-TB4	3.54 (90.0)	1.77 (45.0)	5150 (355)
3/8	0.035	6L-WT3-TB6	3.54 (90.0)	1.77 (45.0)	3330 (230)
1/2	0.049	6L-WT3-TB8	3.54 (90.0)	1.77 (45.0)	3530 (243)
3/4	0.065	6L-WT3-TB12	4.09 (104.0)	2.05 (52.0)	3330 (230)
1	0.065	6L-WT3-TB16	4.33 (110.0)	2.17 (55.0)	2420 (167)
1 1/2	0.065	6L-WT3-TB24	5.83 (148.0)	2.91 (74.0)	1550 (107)
2	0.065	6L-WT3-TB32	6.06 (154.0)	3.07 (78.0)	1160 (80)

Reducing Tees

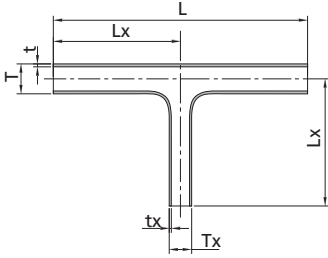

T-Tube O.D. (in.)	t-Wall Thickness (in.)	Tx-Tube O.D. (in.)	tx-Wall Thickness (in.)	Ordering Number	Dimensions, in. (mm)		Working Pressure psig (bar)
					L	Lx	
3/8	0.035	1/4	0.035	6L-WT3-TB6-TB6-TB4	3.54 (90.0)	1.77 (45.0)	3330 (230)
1/2	0.049	1/4	0.035	6L-WT3-TB8-TB8-TB4	3.54 (90.0)	1.77 (45.0)	3530 (243)
1/2	0.049	3/8	0.035	6L-WT3-TB8-TB8-TB6	3.54 (90.0)	1.77 (45.0)	3330 (230)
3/4	0.065	1/4	0.035	6L-WT3-TB12-TB12-TB4	3.70 (94.0)	1.73 (44.0)	3330 (230)
3/4	0.065	3/8	0.035	6L-WT3-TB12-TB12-TB6	3.70 (94.0)	1.73 (44.0)	3330 (230)
3/4	0.065	1/2	0.049	6L-WT3-TB12-TB12-TB8	3.70 (94.0)	1.73 (44.0)	3330 (230)
1	0.065	1/4	0.035	6L-WT3-TB16-TB16-TB4	3.70 (94.0)	1.85 (47.0)	2420 (167)
1	0.065	3/8	0.035	6L-WT3-TB16-TB16-TB6	3.70 (94.0)	1.85 (47.0)	2420 (167)
1	0.065	1/2	0.049	6L-WT3-TB16-TB16-TB8	3.70 (94.0)	1.85 (47.0)	2420 (167)
1	0.065	3/4	0.065	6L-WT3-TB16-TB16-TB12	4.33 (110.0)	2.17 (55.0)	2420 (167)
1 1/2	0.065	1/4	0.035	6L-WT3-TB24-TB24-TB4	4.49 (114.0)	2.13 (54.0)	1550 (107)
1 1/2	0.065	3/8	0.035	6L-WT3-TB24-TB24-TB6	4.49 (114.0)	2.13 (54.0)	1550 (107)
1 1/2	0.065	1/2	0.049	6L-WT3-TB24-TB24-TB8	4.49 (114.0)	2.13 (54.0)	1550 (107)
1 1/2	0.065	3/4	0.065	6L-WT3-TB24-TB24-TB12	5.35 (136.0)	2.44 (62.0)	1550 (107)
1 1/2	0.065	1	0.065	6L-WT3-TB24-TB24-TB16	5.35 (136.0)	2.44 (62.0)	1550 (107)
2	0.065	1/4	0.035	6L-WT3-TB32-TB32-TB4	4.49 (114.0)	2.24 (57.0)	1160 (80)
2	0.065	3/8	0.035	6L-WT3-TB32-TB32-TB6	4.49 (114.0)	2.24 (57.0)	1160 (80)
2	0.065	1/2	0.049	6L-WT3-TB32-TB32-TB8	4.49 (114.0)	2.24 (57.0)	1160 (80)
2	0.065	3/4	0.065	6L-WT3-TB32-TB32-TB12	5.35 (136.0)	2.56 (65.0)	1160 (80)
2	0.065	1	0.065	6L-WT3-TB32-TB32-TB16	5.35 (136.0)	2.56 (65.0)	1160 (80)
2	0.065	1 1/2	0.065	6L-WT3-TB32-TB32-TB24	6.06 (154.0)	3.03 (77.0)	1160 (80)

End Caps

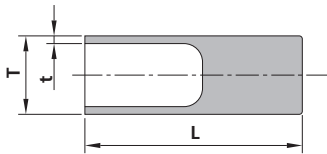

T-Tube O.D. (in.)	t-Wall Thickness (in.)	Ordering Number	Dimensions, in. (mm)	Working Pressure psig (bar)
			L	
1/4	0.035	6L-CW3-TB4	1.12 (28.4)	5150 (355)
3/8	0.035	6L-CW3-TB6	1.12 (28.4)	3330 (230)
1/2	0.049	6L-CW3-TB8	1.37 (34.8)	3530 (243)
3/4	0.065	6L-CW3-TB12	1.75 (44.5)	3330 (230)
1	0.065	6L-CW3-TB16	1.75 (44.5)	2420 (167)
1 1/2	0.065	6L-CW3-TB24	2.00 (50.8)	1550 (167)
2	0.065	6L-CW3-TB32	2.00 (50.8)	1160 (80)

Face Seal Fittings

FR Series



TFO Series



FO Series



Contents

FR Series Metal Gasket Face Seal Fittings

Glands - G

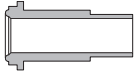

22

Bodies - CM, CMB, CF, U, UB, BU, BW, RU, RA, RB, LM, LU, TTT, C

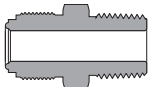

26

Welded Glands - WG

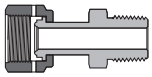

31

Nuts - N, MN, BC

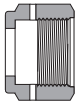

32

Plugs - PG



33

Caps - CP



33

Flow Restrictors



34

Gaskets - GT



34

High-Flow Connections - "H" type FR

36

TFO Series L-ring Face Seal Fittings

Glands - G

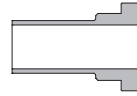

40

Nuts - N

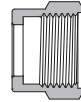

40

Tube Butt Weld Bodies - CW

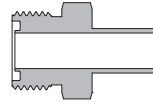

41

L-ring Seal - GT



41

FO Series O-ring Face Seal Fittings

Glands - G



44

Welded Glands - WG

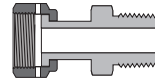

45

Nuts - N



46

Bodies - CM, CF, U, UB, BY, BU, CW, LM, LU, LP, LU, TTT

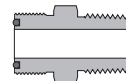

46

O-rings



50

Face Seal Fittings

FR Series Face Seal Fittings

Features

- ⦿ Metal-to-metal seal to provide perfect leak-tight service for working conditions from critical vacuum to high pressure
- ⦿ Precision manufactured gasket to ensure best performance
- ⦿ Test port at nut for easy leak testing
- ⦿ Silver-plated female threads
- ⦿ Standard surface roughness finished to an average of Ra 10 μm . (0.25 μm) or electropolished to Ra 5 μm . (0.13 μm) optional
- ⦿ All seal faces and male threads protected with plastic caps
- ⦿ Every gland and body marked with size, material and heat code



Technical Data

- ⦿ Sizes range from 1/16" to 1" and 6 mm to 18 mm
- ⦿ Thread Specifications:

Thread Type	Specification
NPT	ASME B1.20.1, SAE AS71051
Unified (SAE)	ASME B1.1, SAE J475

- ⦿ Materials:

Material	Bar Stock	Forging	Designator
Fitting Material			
316 SS	ASTM A276	ASME SA182	SS
316L SS	ASME SA479	ASTM A314	6L
316L VAR SS	SEMI F20		6LV
Gasket Material			
316L SS	ASTM A240		6L
Copper	ASTM B152		CU
Nickel	ASTM B162		NI

- ⦿ Working Pressure:
Working pressures shown in the Catalog are calculated according to ASME B31.3 and B31.1 at ambient temperature.

- ⦿ Working Temperature:

Component	Material	Max. Temperature
Fittings	316 SS	1000°F (538°C)
	316L SS	
	316L VAR SS	
Gaskets	316L SS	400°F (204°C)
	Copper	
	Nickel	

Testing

Every FR fitting is Helium leak tested to a maximum allowable leak rate of 4×10^{-9} std cm^3/s .

Ordering Information

- ⦿ Each component can be ordered separately.
- ⦿ Add the material designator as a prefix, cleaning and packaging code as a suffix to the basic ordering number to get the complete ordering number.
- ⦿ Cleaning and Packaging
 - a. FC-01 Standard Cleaning and Packaging for general industrial procedures. No suffix is needed.
 - b. FC-02 Special Cleaning and Packaging, to ensure compliance with product cleanliness requirement as stated in ASTM G93 Level C. Add "-F2" as a suffix when needed.
 - c. FC-03 Ultra-High Purity Process Specification is applied to products with wetted surface roughness finished to an average of Ra 5 μin . (0.13 μm). Add "-F3" as suffix when needed. It is only available for 316L and 316L VAR SS fittings.

Example: For 1/2" 316L VAR SS gland with FC-03 Ultra-High Purity Process Specification, the complete ordering number is 6LV-G-FR8-TB8-6-F3.

Installation Instructions

1. Assemble the gland, nut, gasket and male nut as below. Finger tight the nut.

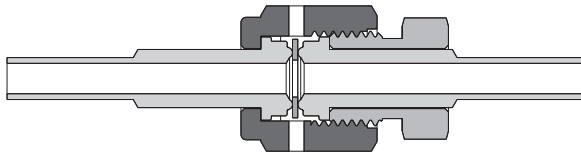

2. For fittings with 316L SS and Nickel gaskets, tighten the nut 1/8 turn with a wrench while holding the male nut or the fitting body steady. Tighten the nut 1/4 turn for those with Copper gaskets.

Cautions

- ⦿ Dimensions are for reference only and are subject to change.
- ⦿ Over-tightening will damage the sealing beads and lead to possible leak.
- ⦿ Utilize a new gasket for each assembly.
- ⦿ Tungsten Inert Gas Welding (TIG) is recommended.
- ⦿ Always apply proper thread sealants on tapered pipe threads.
- ⦿ Do not loosen or tighten fittings when system is pressurized.

Glands

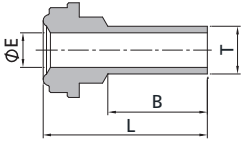

FR Gland to Short Fractional Tube Butt Weld

FR Size (in.)	T-Tube O.D. (in.)	Nominal Wall Thickness (in.)	Basic Ordering Number	Dimensions, in. (mm)			Working Pressure, psig (bar)		
				L	B	E	6L	CU	NI
1/8	1/8	0.028	-G-FR2-TB2-12S	1.08 (27.4)	0.75 (19.1)	0.06 (1.5)	8500 (586)	6800 (468)	8500 (586)
1/4	1/8	0.028	-G-FR4-TB2-12S	1.10 (27.9)	0.75 (19.1)	0.06 (1.5)	5100 (351)	5100 (351)	5100 (351)
1/4	1/4	0.035	-G-FR4-TB4-4S	0.60 (15.2)	0.25 (6.4)	0.18 (4.6)	5100 (351)	5100 (351)	5100 (351)
1/4	1/4	0.035	-G-FR4-TB4-6S	0.72 (18.3)	0.38 (9.6)	0.18 (4.6)	5100 (351)	5100 (351)	5100 (351)
1/4	1/4	0.035	-G-FR4-TB4-12S	1.10 (27.9)	0.75 (19.1)	0.18 (4.6)	5100 (351)	5100 (351)	5100 (351)
1/2	1/4	0.035	-G-FR8-TB4-12S	1.12 (28.4)	0.75 (19.1)	0.18 (4.6)	4300 (296)	2800 (192)	3500 (241)
1/2	3/8	0.035	-G-FR8-TB6-4S	0.62 (15.7)	0.25 (6.4)	0.31 (7.9)	3300 (227)	2600 (179)	3300 (227)
1/2	3/8	0.035	-G-FR8-TB6-12S	1.12 (28.4)	0.75 (19.1)	0.31 (7.9)	3300 (227)	2600 (179)	3300 (227)
1/2	1/2	0.049	-G-FR8-TB8-4S	0.62 (15.7)	0.25 (6.4)	0.40 (10.2)	3500 (241)	2800 (192)	3500 (241)
1/2	1/2	0.049	-G-FR8-TB8-6S	0.74 (18.8)	0.38 (9.6)	0.40 (10.2)	3500 (241)	2800 (192)	3500 (241)
1/2	1/2	0.049	-G-FR8-TB8-12S	1.12 (28.4)	0.75 (19.1)	0.40 (10.2)	3500 (241)	2800 (192)	3500 (241)

FR Gland to Short Metric Tube Butt Weld

FR Size (in.)	T-Tube O.D. (mm)	Nominal Wall Thickness (mm)	Basic Ordering Number	Dimensions, mm (in.)			Working Pressure, bar (psig)		
				L	B	E	6L	CU	NI
1/4	6	1.0	-G-FR4-MTB6-12S	29.5 (1.16)	19.1 (0.75)	4.0 (0.16)	468 (6800)	372 (5400)	468 (6800)
1/4	8	1.0	-G-FR4-MTB8-12S	29.5 (1.16)	19.1 (0.75)	6.0 (0.24)	337 (4900)	337 (4900)	337 (4900)
1/2	10	1.0	-G-FR8-MTB10-12S	29.5 (1.16)	19.1 (0.75)	8.0 (0.31)	241 (3500)	192 (2800)	241 (3500)
1/2	12	1.0	-G-FR8-MTB12-12S	29.5 (1.16)	19.1 (0.75)	10.0 (0.39)	213 (3100)	165 (2400)	213 (3100)
3/4	18	1.5	-G-FR12-MTB18-12S	31.0 (1.22)	19.1 (0.75)	15.0 (0.59)	206 (3000)	165 (2400)	206 (3000)

F-23 Face Seal Fittings

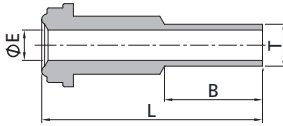

FR Gland to Long Fractional Tube Butt Weld

FR Size (in.)	T-Tube O.D. (in.)	Nominal Wall Thickness (in.)	Basic Ordering Number	Dimensions, in. (mm)			Working Pressure, psig (bar)		
				L	B	E	6L	CU	NI
1/8	1/8	0.028	-G-FR2-TB2-12	1.42 (36.1)	0.75 (19.1)	0.06 (1.5)	8500 (586)	6800 (468)	8500 (586)
1/4	1/4	0.035	-G-FR4-TB4-4	1.20 (30.5)	0.25 (6.4)	0.18 (4.6)	5100 (351)	5100 (351)	5100 (351)
1/4	1/4	0.035	-G-FR4-TB4-1.31 [Ⓢ]	1.31 (33.3)	0.36 (9.1)	0.18 (4.6)	5100 (351)	5100 (351)	5100 (351)
1/4	1/4	0.035	-G-FR4-TB4-6	1.32 (33.5)	0.38 (9.6)	0.18 (4.6)	5100 (351)	5100 (351)	5100 (351)
1/4	1/4	0.035	-G-FR4-TB4-12	1.70 (43.2)	0.75 (19.1)	0.18 (4.6)	5100 (351)	5100 (351)	5100 (351)
1/2	1/4	0.035	-G-FR8-TB4-12	1.80 (45.7)	0.75 (19.1)	0.18 (4.6)	4300 (296)	2800 (192)	3500 (241)
1/2	3/8	0.035	-G-FR8-TB6-4	1.29 (32.8)	0.25 (6.4)	0.31 (7.9)	3300 (227)	2600 (179)	3300 (227)
1/2	3/8	0.035	-G-FR8-TB6-12	1.79 (45.5)	0.75 (19.1)	0.31 (7.9)	3300 (227)	2600 (179)	3300 (227)
1/2	1/2	0.049	-G-FR8-TB8-4	1.29 (32.8)	0.25 (6.4)	0.40 (10.2)	3500 (241)	2800 (192)	3500 (241)
1/2	1/2	0.049	-G-FR8-TB8-6	1.41 (35.8)	0.38 (9.6)	0.40 (10.2)	3500 (241)	2800 (192)	3500 (241)
1/2	1/2	0.049	-G-FR8-TB8-12	1.79 (45.5)	0.75 (19.1)	0.40 (10.2)	3500 (241)	2800 (192)	3500 (241)
3/4	3/4	0.049	-G-FR12-TB12-12	2.03 (51.6)	0.75 (19.1)	0.65 (16.5)	2400 (165)	1900 (130)	2400 (165)
1	1	0.065	-G-FR16-TB16-12	2.32 (58.9)	0.75 (19.1)	0.87 (22.1)	2400 (165)	1900 (130)	2400 (165)

FR Gland to Long Metric Tube Butt Weld

FR Size (in.)	T-Tube O.D. (mm)	Nominal Wall Thickness (mm)	Basic Ordering Number	Dimensions, mm (in.)			Working Pressure, bar (psig)		
				L	B	E	6L	CU	NI
1/4	6	1.0	-G-FR4-MTB6-12	43.2 (1.7)	19.1 (0.75)	4.0 (0.16)	468 (6800)	372 (5400)	468 (6800)
1/4	8	1.0	-G-FR4-MTB8-12	43.2 (1.7)	19.1 (0.75)	6.0 (0.24)	337 (4900)	337 (4900)	337 (4900)
1/2	10	1.0	-G-FR8-MTB10-12	45.5 (1.79)	19.1 (0.75)	8.0 (0.31)	241 (3500)	192 (2800)	241 (3500)
1/2	12	1.0	-G-FR8-MTB12-12	45.5 (1.79)	19.1 (0.75)	10.0 (0.39)	213 (3100)	165 (2400)	213 (3100)
3/4	18	1.5	-G-FR12-MTB18-12	51.6 (2.03)	19.1 (0.75)	15.0 (0.59)	206 (3000)	165 (2400)	206 (3000)

Suffix -4, -6, -12 indicates that Dimension B equals to the specific suffix value times 1/16. Example: With suffix "12", Dimension B= 12/16 = 3/4" or 19.1 mm.
 Ⓢ -1.31 means the length of Dim L.

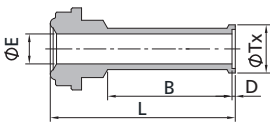

FR Gland to Short Fractional Automatic Tube Butt Weld

FR Size (in.)	Tube O.D. (in.)	Nominal Wall Thickness (in.)	Basic Ordering Number	Dimensions, in. (mm)					Working Pressure, psig (bar)		
				L	B	D	E	Tx	6L	CU	NI
1/4	1/4	0.035	-AG-FR4-TB4-12S	1.12 (28.4)	0.75 (19.1)	0.02 (0.5)	0.18 (4.6)	0.29 (7.4)	5100 (351)	5100 (351)	5100 (351)
1/2	3/8	0.035	-AG-FR8-TB6-12S	1.15 (29.2)	0.75 (19.1)	0.03 (0.8)	0.31 (7.9)	0.41 (10.4)	3300 (227)	2600 (179)	3300 (227)
1/2	1/2	0.049	-AG-FR8-TB8-12S	1.16 (29.5)	0.75 (19.1)	0.04 (1.0)	0.40 (10.2)	0.55 (14.0)	3500 (241)	2800 (192)	3500 (241)

FR Gland to Short Metric Automatic Tube Butt Weld

FR Size (in.)	Tube O.D. (mm)	Nominal Wall Thickness (mm)	Basic Ordering Number	Dimensions, mm (in.)					Working Pressure, bar (psig)		
				L	B	D	E	Tx	6L	CU	NI
1/4	6	1.0	-AG-FR4-MTB6-12S	30.0 (1.18)	19.1 (0.75)	0.5 (0.02)	4.0 (0.16)	6.8 (0.27)	468 (6800)	372 (5400)	468 (6800)
1/4	8	1.0	-AG-FR4-MTB8-12S	30.2 (1.19)	19.1 (0.75)	0.8 (0.03)	6.0 (0.24)	8.9 (0.35)	337 (4900)	337 (4900)	337 (4900)
1/2	10	1.0	-AG-FR8-MTB10-12S	31.0 (1.22)	19.1 (0.75)	0.8 (0.03)	8.0 (0.31)	10.9 (0.43)	241 (3500)	192 (2800)	241 (3500)
1/2	12	1.0	-AG-FR8-MTB12-12S	30.5 (1.20)	19.1 (0.75)	1.0 (0.04)	10.0 (0.39)	13.2 (0.52)	213 (3100)	165 (2400)	213 (3100)

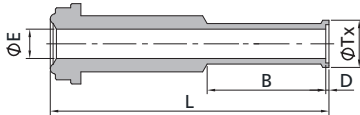

FR Gland to Long Fractional Automatic Tube Butt Weld

FR Size (in.)	Tube O.D. (in.)	Nominal Wall Thickness (in.)	Basic Ordering Number	Dimensions, in. (mm)					Working Pressure, psig (bar)		
				L	B	D	E	Tx	6L	CU	NI
1/4	1/4	0.035	-AG-FR4-TB4-12	1.72 (43.7)	0.75 (19.1)	0.02 (0.5)	0.18 (4.6)	0.29 (7.4)	5100 (351)	5100 (351)	5100 (351)
1/2	1/4	0.035	-AG-FR8-TB4-12	1.82 (46.2)	0.75 (19.1)	0.02 (0.5)	0.18 (4.6)	0.29 (7.4)	3500 (241)	2800 (192)	3500 (241)
1/2	3/8	0.035	-AG-FR8-TB6-12	1.82 (46.2)	0.75 (19.1)	0.03 (0.8)	0.31 (7.9)	0.41 (10.4)	3300 (227)	2600 (179)	3300 (227)
1/2	1/2	0.049	-AG-FR8-TB8-12	1.83 (46.5)	0.75 (19.1)	0.04 (1.0)	0.40 (10.2)	0.55 (14.0)	3500 (241)	2800 (192)	3500 (241)
3/4	3/4	0.049	-AG-FR12-TB12-12	2.07 (52.6)	0.75 (19.1)	0.04 (1.0)	0.65 (16.5)	0.80 (20.3)	2400 (165)	2400 (165)	2400 (165)
1	1	0.065	-AG-FR16-TB16-16	2.57 (65.3)	0.96 (24.4)	0.04 (1.0)	0.87 (22.1)	1.06 (26.9)	2400 (165)	1900 (130)	2400 (165)

FR Gland to Long Metric Automatic Tube Butt Weld

FR Size (in.)	Tube O.D. (mm)	Nominal Wall Thickness (mm)	Basic Ordering Number	Dimensions, mm (in.)					Working Pressure, bar (psig)		
				L	B	D	E	Tx	6L	CU	NI
1/4	6	1.0	-AG-FR4-MTB6-12	43.7 (1.72)	19.1 (0.75)	0.5 (0.02)	4.0 (0.16)	6.8 (0.27)	468 (6800)	372 (5400)	468 (6800)
1/2	12	1.0	-AG-FR8-MTB12-12	46.5 (1.83)	19.1 (0.75)	1.0 (0.04)	10.0 (0.39)	13.2 (0.52)	213 (3100)	165 (2400)	213 (3100)
3/4	18	1.5	-AG-FR12-MTB18-12	52.6 (2.07)	19.1 (0.75)	1.0 (0.04)	15.0 (0.59)	19.3 (0.76)	206 (3000)	165 (2400)	206 (3000)

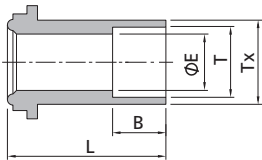

FR Gland to Short Tube Socket Weld

FR Size (in.)	T-Tube O.D. (in.)	Basic Ordering Number	Dimensions, in. (mm)				Working Pressure, psig (bar)		
			L	B	E	Tx	6L	CU	NI
1/4	1/4	-G-FR4-TS4-0.50	0.50 (12.7)	0.28 (7.1)	0.18 (4.6)	0.35 (8.9)	5500 (378)	5500 (378)	5500 (378)
1/4	1/4	-G-FR4-TS4-0.75	0.75 (19.1)	0.28 (7.1)	0.18 (4.6)	0.35 (8.9)	5500 (378)	5500 (378)	5500 (378)

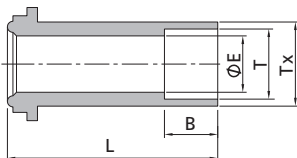

FR Gland to Tube Socket Weld

FR Size (in.)	T-Tube O.D. (in.)	Basic Ordering Number	Dimensions, in. (mm)				Working Pressure, psig (bar)		
			L	B	E	Tx	6L	CU	NI
1/8	1/16	-G-FR2-TS1	0.70 (17.8)	0.10 (2.5)	0.05 (1.3)	0.13 (3.3)	9000 (620)	7200 (496)	9000 (620)
1/8	1/8	-G-FR2-TS2	0.70 (17.8)	0.10 (2.5)	0.09 (2.3)	0.20 (5.1)	7100 (489)	7100 (489)	7100 (489)
1/4	1/4	-G-FR4-TS4	1.31 (33.3)	0.28 (7.1)	0.18 (4.6)	0.35 (8.9)	5500 (378)	5500 (378)	5500 (378)
1/2	3/8	-G-FR8-TS6	1.50 (38.1)	0.31 (7.9)	0.28 (7.1)	0.60 (15.2)	4300 (296)	2800 (192)	3500 (241)
1/2	1/2	-G-FR8-TS8	1.50 (38.1)	0.38 (9.7)	0.40 (10.2)	0.60 (15.2)	3000 (206)	2400 (165)	3000 (206)
5/8	5/8	-G-FR10-TS10	1.56 (39.6)	0.41 (10.4)	0.50 (12.7)	0.72 (18.3)	2800 (192)	2200 (151)	2800 (192)
3/4	3/4	-G-FR12-TS12	2.00 (50.8)	0.44 (11.2)	0.62 (15.7)	0.88 (22.4)	2800 (192)	2200 (151)	2800 (192)
1	1	-G-FR16-TS16	2.22 (56.4)	0.62 (15.7)	0.87 (22.1)	1.19 (30.2)	3000 (206)	1900 (130)	2400 (165)

F-25 Face Seal Fittings

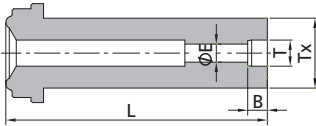

Reducing Socket Weld

FR Size (in.)	T-Tube O.D. (in.)	Basic Ordering Number	Dimensions, in. (mm)				Working Pressure, psig (bar)		
			L	B	E	Tx	6L	CU	NI
1/4	1/8	-G-FR4-RTS2	1.31 (33.3)	0.10 (2.5)	0.09 (2.3)	0.35 (8.9)	8000 (551)	8000 (551)	8000 (551)
1/2	1/4	-G-FR8-RTS4	1.50 (38.1)	0.28 (7.1)	0.18 (4.6)	0.60 (15.2)	3500 (241)	3500 (241)	3500 (241)

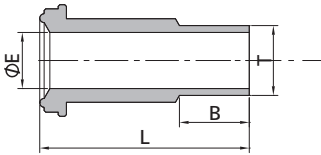

FR Gland to Male Weld

FR Size (in.)	T-Tube O.D. (in.)	Basic Ordering Number	Dimensions, in. (mm)			Working Pressure, psig (bar)		
			L	B	E	6L	CU	NI
1/8	1/8	-G-FR2-TB2	0.70 (17.8)	0.28 (7.1)	0.06 (1.5)	11200 (772)	7200 (496)	9000 (620)
1/4	1/8	-G-FR4-TB2	1.31 (33.3)	0.28 (7.1)	0.06 (1.5)	10000 (690)	6400 (440)	8000 (551)
1/4	1/4	-G-FR4-TB4	1.31 (33.3)	0.41 (10.4)	0.12 (3.0)	10000 (690)	6400 (440)	8000 (551)
1/2	1/4	-G-FR8-TB4	1.50 (38.1)	0.41 (10.4)	0.12 (3.0)	4300 (296)	2800 (192)	3500 (241)
1/2	3/8	-G-FR8-TB6	1.50 (38.1)	0.41 (10.4)	0.28 (7.1)	4300 (296)	2800 (192)	3500 (241)
1/2	1/2	-G-FR8-TB8	1.50 (38.1)	0.50 (12.7)	0.40 (10.2)	3500 (241)	3500 (241)	3500 (241)
3/4	3/4	-G-FR12-TB12	2.00 (50.8)	0.62 (15.7)	0.53 (13.5)	3700 (254)	2400 (165)	3000 (206)
1	1	-G-FR16-TB16	2.22 (56.4)	0.81 (20.6)	0.75 (19.1)	3000 (206)	1900 (130)	2400 (165)

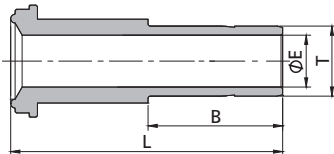

FR Gland to Tube Port

FR Size (in.)	T-Tube O.D. (in.)	Basic Ordering Number	Dimensions, in. (mm)			Working Pressure, psig (bar)		
			L	B	E	6L	CU	NI
1/4	1/4	-G-FR4-FT4	1.62 (41.0)	0.64 (16.2)	0.17 (4.3)	10000 (690)	6400 (440)	8000 (551)
1/2	3/8	-G-FR8-FT6	1.81 (46.0)	0.70 (17.8)	0.27 (6.9)	4300 (296)	2800 (192)	3500 (241)
1/2	1/2	-G-FR8-FT8	1.94 (49.3)	0.96 (24.4)	0.37 (9.4)	4300 (296)	2800 (192)	3500 (241)

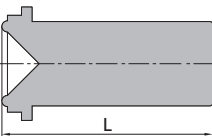

Blind Gland

FR Size (in.)	Basic Ordering Number	Dimensions, in. (mm)
		L
1/8	-G-FR2-B	0.70 (17.8)
1/4	-G-FR4-B	1.31 (33.3)
1/2	-G-FR8-B	1.50 (38.1)
3/4	-G-FR12-B	2.00 (50.8)
1	-G-FR16-B	2.22 (56.4)

Bodies

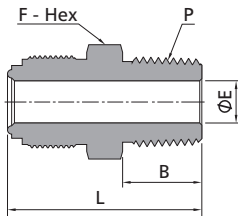

FR Body to Male NPT

FR Size (in.)	P-NPT Size	Basic Ordering Number	Dimensions, in. (mm)				Working Pressure, psig (bar)		
			L	B	E	F	6L	CU	NI
1/8	1/16	-CM-FR2-NS1	1.07 (27.2)	0.38 (9.7)	0.09 (2.3)	3/8 (9.5)	9000 (620)	7200 (496)	9000 (620)
1/8	1/8	-CM-FR2-NS2	1.07 (27.2)	0.38 (9.7)	0.09 (2.3)	7/16 (11.1)	9000 (620)	7200 (496)	9000 (620)
1/4	1/8	-CM-FR4-NS2	1.31 (33.3)	0.38 (9.7)	0.18 (4.6)	5/8 (15.9)	10000 (690)	6400 (440)	8000 (551)
1/4	1/4	-CM-FR4-NS4	1.49 (37.8)	0.56 (14.2)	0.18 (4.6)	5/8 (15.9)	10000 (690)	6400 (440)	8000 (551)
1/2	1/4	-CM-FR8-NS4	1.65 (41.9)	0.56 (14.2)	0.28 (7.1)	15/16 (23.8)	4300 (296)	2800 (192)	3500 (241)
1/2	3/8	-CM-FR8-NS6	1.65 (41.9)	0.56 (14.2)	0.38 (9.7)	15/16 (23.8)	4300 (296)	2800 (192)	3500 (241)
1/2	1/2	-CM-FR8-NS8	1.84 (46.7)	0.75 (19.1)	0.40 (10.2)	15/16 (23.8)	4300 (296)	2800 (192)	3500 (241)
3/4	3/4	-CM-FR12-NS12	2.19 (55.6)	0.75 (19.1)	0.62 (15.7)	1 15/16 (33.3)	3700 (254)	2400 (165)	3000 (206)
1	1	-CM-FR16-NS16	2.47 (62.7)	0.94 (23.9)	0.87 (22.1)	1 5/8 (41.3)	3000 (206)	1900 (130)	3000 (206)

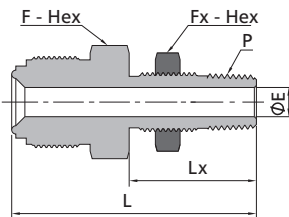

FR Body to Bulkhead Male Connector

FR Size (in.)	P-NPT Size	Basic Ordering Number	Dimensions, in. (mm)					Panel Hole Size in. (mm)	Max. Panel Thickness in. (mm)	Working Pressure, psig (bar)		
			L	Lx	E	F	Fx			6L	CU	NI
1/4	1/4	-CMB-FR4-NS4	2.21 (56.1)	1.24 (31.5)	0.28 (7.1)	13/16 (20.6)	13/16 (20.6)	21/32 (16.7)	0.38 (9.7)	8000 (551)	6400 (440)	8000 (551)
1/2	1/4	-CMB-FR8-NS4	2.34 (59.4)	1.24 (31.5)	0.28 (7.1)	15/16 (23.8)	13/16 (20.6)	21/32 (16.7)	0.38 (9.7)	4370 (301)	2800 (192)	3500 (241)

F-27 Face Seal Fittings

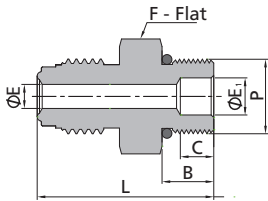

FR Body to SAE/MS Thread

FR Size (in.)	P-SAE/MS Thread Size	Uniform O-ring ^① Size	Basic Ordering Number	Dimensions, in. (mm)						Working Pressure, psig (bar)		
				L	B	C	E	E ₁	F	6L	CU	NI
1/4	9/16-18	906	-CM-FR4-ST9	1.33 (33.8)	0.39 (9.9)	0.25 (6.4)	0.18 (4.6)	0.28 (7.1)	3/4 (19.1)	4500 (310)	4500 (310)	4500 (310)
1/2	9/16-18	906	-CM-FR8-ST9	1.48 (37.6)	0.39 (9.9)	-	0.28 (7.1)	0.28 (7.1)	15/16 (23.8)	3500 (241)	2800 (192)	3500 (241)
1/2	7/8-14	910	-CM-FR8-ST14	1.66 (42.2)	0.50 (12.7)	0.40 (10.2)	0.28 (7.1)	0.59 (15.0)	1 (25.4)	3500 (241)	2800 (192)	3500 (241)

① Fluorocarbon FKM is standard O-ring material, contact FITOK Group for other materials.

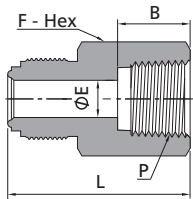

FR Body to Female NPT

FR Size (in.)	P-NPT Size	Basic Ordering Number	Dimensions, in. (mm)				Working Pressure, psig (bar)		
			L	B	E	F	6L	CU	NI
1/8	1/16	-CF-FR2-NS1	1.10 (27.9)	0.39 (9.9)	0.09 (2.3)	7/16 (11.1)	6700 (461)	6700 (461)	6700 (461)
1/8	1/8	-CF-FR2-NS2	1.19 (30.2)	0.41 (10.4)	0.09 (2.3)	9/16 (14.3)	6500 (447)	6500 (447)	6500 (447)
1/4	1/8	-CF-FR4-NS2	1.41 (35.8)	0.41 (10.4)	0.18 (4.6)	5/8 (15.9)	8000 (551)	6400 (440)	8000 (551)
1/4	1/4	-CF-FR4-NS4	1.54 (39.1)	0.59 (15.0)	0.18 (4.6)	3/4 (19.1)	6600 (454)	5200 (358)	6600 (454)
1/2	3/8	-CF-FR8-NS6	1.76 (44.7)	0.59 (15.0)	0.40 (10.2)	15/16 (23.8)	4300 (296)	2800 (192)	3500 (241)
1/2	1/2	-CF-FR8-NS8	1.99 (50.5)	0.78 (19.8)	0.40 (10.2)	1 1/16 (27.0)	4300 (296)	2800 (192)	3500 (241)
3/4	3/4	-CF-FR12-NS12	2.36 (59.9)	0.81 (20.6)	0.62 (15.7)	1 5/16 (33.3)	3700 (254)	2400 (165)	3000 (206)
1	1	-CF-FR16-NS16	2.51 (63.8)	1.00 (25.4)	0.87 (22.1)	1 5/8 (41.3)	3000 (206)	1900 (130)	2400 (165)

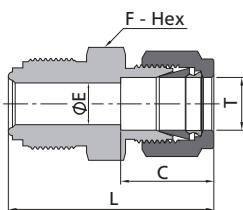

FR Body to Tube Fitting

FR Size (in.)	T-Tube O.D. (in.)	Basic Ordering Number	Dimensions, in. (mm)				Working Pressure, psig (bar)		
			L ^①	C	E	F	6L	CU	NI
1/4	1/8	-U-FR4-FL2	1.53 (38.9)	0.50 (12.7)	0.09 (2.3)	5/8 (15.9)	10000 (690)	6400 (440)	8000 (551)
1/4	1/4	-U-FR4-FL4	1.62 (41.1)	0.60 (15.2)	0.18 (4.6)	5/8 (15.9)	10000 (690)	6400 (440)	8000 (551)
1/2	3/8	-U-FR8-FL6	1.84 (46.7)	0.66 (16.8)	0.28 (7.1)	15/16 (23.8)	4300 (296)	2800 (192)	3500 (241)
1/2	1/2	-U-FR8-FL8	1.95 (49.5)	0.90 (22.9)	0.40 (10.2)	15/16 (23.8)	4300 (296)	2800 (192)	3500 (241)

① Dimension L is with FITOK nuts finger-tight.

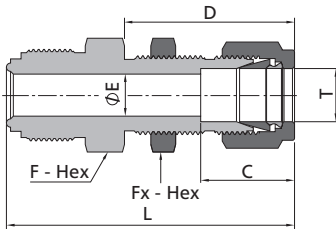

FR Body to Bulkhead Tube Fitting Union

FR T-Tube Size (in.)	O.D. (in.)	Basic Ordering Number	Dimensions, in. (mm)						Panel Hole Size in. (mm)	Max. Panel Thickness in. (mm)	Working Pressure, psig (bar)		
			L ^①	C	D	E	F	Fx			6L	CU	NI
1/4	1/4	-UB-FR4-FL4	2.25 (57.2)	0.60 (15.2)	1.32 (33.5)	0.18 (4.6)	5/8 (15.9)	5/8 (15.9)	15/32 (11.9)	0.40 (10.2)	10000 (690)	6400 (440)	8000 (551)
1/4	1/4	-UB-FR4-FL4-1.88	1.88 (47.8)	0.60 (15.2)	1.05 (26.7)	0.18 (4.6)	5/8 (15.9)	5/8 (15.9)	15/32 (11.9)	0.13 (3.3)	10000 (690)	6400 (440)	8000 (551)
1/2	3/8	-UB-FR8-FL6	2.54 (64.5)	0.66 (16.8)	1.45 (36.8)	0.28 (7.1)	15/16 (23.8)	3/4 (19.1)	19/32 (15.0)	0.44 (11.2)	4300 (296)	2800 (192)	3500 (241)
1/2	1/2	-UB-FR8-FL8	2.74 (69.6)	0.90 (22.9)	1.65 (41.9)	0.40 (10.2)	15/16 (23.8)	15/16 (23.8)	25/32 (19.8)	0.50 (12.7)	4300 (296)	2800 (192)	3500 (241)

① Dimension L is with FITOK nuts finger-tight.

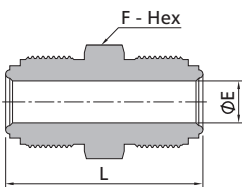

Union Body

FR Size (in.)	FR Size (in.)	Basic Ordering Number	Dimensions, in. (mm)			Working Pressure, psig (bar)		
			L	E	F	6L	CU	NI
1/8	1/8	-U-FR2	1.13 (28.7)	0.09 (2.3)	3/8 (9.5)	11200 (772)	7200 (496)	9000 (620)
1/4	1/4	-U-FR4	1.55 (39.4)	0.18 (4.6)	5/8 (15.9)	10000 (690)	6400 (440)	8000 (551)
1/2	1/2	-U-FR8	1.84 (46.7)	0.40 (10.2)	15/16 (23.8)	4300 (296)	2800 (192)	3500 (241)
3/4	3/4	-U-FR12	2.44 (62.0)	0.62 (15.7)	1 5/16 (33.3)	3700 (254)	2400 (165)	3000 (206)
1	1	-U-FR16	2.59 (65.8)	0.87 (22.1)	1 5/8 (41.3)	3000 (206)	1900 (130)	2400 (165)

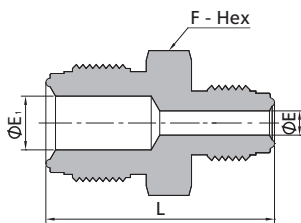

Reducing Union

FR Size (in.)	FR Size (in.)	Basic Ordering Number	Dimensions, in. (mm)				Working Pressure, psig (bar)		
			L	E	E ₁	F	6L	CU	NI
1/4	1/8	-U-FR4-FR2	1.37 (34.8)	0.09 (2.3)	0.18 (4.6)	5/8 (15.9)	10000 (690)	6400 (440)	8000 (551)
1/2	1/4	-U-FR8-FR4	1.71 (43.4)	0.18 (4.6)	0.40 (10.2)	5/16 (23.8)	4300 (296)	2800 (192)	3500 (241)

F-29 Face Seal Fittings

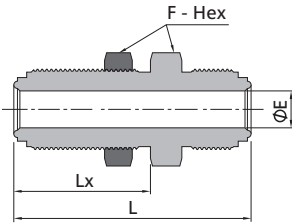

Bulkhead Union Body										
FR Size (in.)	Basic Ordering Number	Dimensions, in. (mm)				Panel Hole Drill Size in. (mm)	Max. Panel Thickness in. (mm)	Working Pressure, psig (bar)		
		L	Lx	E	F			6L	CU	NI
1/4	-BU-FR4-1.82	1.82 (46.2)	0.99 (25.1)	0.18 (4.6)	3/4 (19.1)	19/32 (15.0)	0.13 (3.3)	10000 (690)	6400 (440)	8000 (551)
1/4	-BU-FR4	2.23 (56.6)	1.30 (33.3)	0.18 (4.6)	3/4 (19.1)	19/32 (15.0)	0.44 (11.2)	10000 (690)	6400 (440)	8000 (551)
1/2	-BU-FR8-2.14	2.14 (54.4)	1.11 (28.2)	0.40 (10.2)	1 1/16 (27.0)	29/32 (23.1)	0.13 (3.3)	4300 (296)	2800 (192)	3500 (241)
1/2	-BU-FR8	2.57 (65.3)	1.48 (37.6)	0.40 (10.2)	1 1/16 (27.0)	29/32 (23.1)	0.50 (12.7)	4300 (296)	2800 (192)	3500 (241)

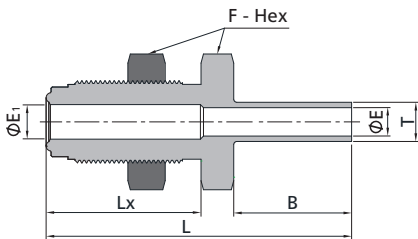

FR Bulkhead Body to Tube Butt Weld													
FR Size (in.)	T-Tube O.D. (in.)	Basic Ordering Number	Dimensions, in. (mm)					Panel Hole Drill Size in. (mm)	Max. Panel Thickness in. (mm)	Working Pressure, psig (bar)			
			L	Lx	B	E	E ₁			F	6L	CU	NI
1/4	1/4	-BW-FR4-TB4-1.95	1.95 (49.5)	0.99 (25.1)	0.75 (19.1)	0.18 (4.6)	0.22 (5.6)	0.75 (19.1)	19/32 (15.1)	0.13 (3.3)	5100 (351)	5100 (351)	5100 (351)
1/4	1/4	-BW-FR4-TB4	2.36 (59.9)	1.30 (33.0)	0.75 (19.1)	0.18 (4.6)	0.22 (5.6)	0.75 (19.1)	19/32 (15.1)	0.44 (11.2)	5100 (351)	5100 (351)	5100 (351)

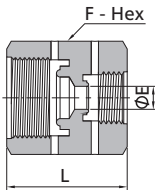

Female Reducing Union									
FR Size (in.)	FR Size (in.)	Basic Ordering Number	Dimensions, in. (mm)			Working Pressure, psig (bar)			
			L	E	F	6L	CU	NI	
1/4	1/8	-RU-FR4-FR2	1.16 (29.5)	0.13 (3.3)	3/4 (19.1)	10000 (690)	6400 (440)	8000 (551)	
1/2	1/4	-RU-FR8-FR4	1.41 (35.8)	0.25 (6.4)	1 1/16 (27.0)	4300 (296)	2800 (192)	3500 (241)	

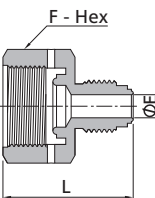

Reducing Adapter									
FR Size (in.)	FR Size (in.)	Basic Ordering Number	Dimensions, in. (mm)			Working Pressure, psig (bar)			
			L	E	F	6L	CU	NI	
1/4	1/8	-RA-FR4-FR2	1.19 (30.2)	0.09 (2.3)	3/4 (19.1)	10000 (690)	6400 (440)	8000 (551)	
1/2	1/4	-RA-FR8-FR4	1.41 (35.8)	0.18 (4.6)	1 1/16 (27.0)	4300 (296)	2800 (192)	3500 (241)	

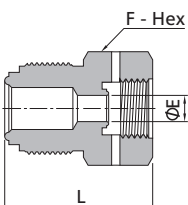

Reducing Bushing									
FR Size (in.)	FR Size (in.)	Basic Ordering Number	Dimensions, in. (mm)			Working Pressure, psig (bar)			
			L	E	F	6L	CU	NI	
1/4	1/8	-RB-FR4-FR2	1.06 (26.9)	0.13 (3.3)	5/8 (15.9)	10000 (690)	6400 (440)	8000 (551)	
1/2	1/4	-RB-FR8-FR4	1.41 (35.8)	0.25 (6.4)	15/16 (23.8)	4300 (296)	2800 (192)	3500 (241)	

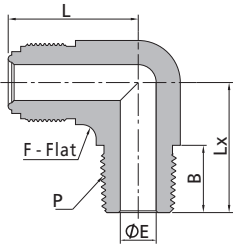

FR Body to Male NPT Elbow										
FR Size (in.)	P-NPT Size	Basic Ordering Number	Dimensions, in. (mm)					Working Pressure, psig (bar)		
			L	Lx	B	E	F	6L	CU	NI
1/4	1/8	-LM-FR4-NS2	1.07 (27.2)	0.87 (22.1)	0.38 (9.6)	0.18 (4.6)	1/2 (12.7)	10000 (690)	6400 (440)	8000 (551)
1/4	1/4	-LM-FR4-NS4	1.07 (27.2)	1.05 (26.7)	0.56 (14.2)	0.18 (4.6)	1/2 (12.7)	8000 (551)	8000 (551)	8000 (551)
1/2	3/8	-LM-FR8-NS6	1.45 (36.8)	1.26 (32.0)	0.56 (14.2)	0.40 (10.2)	13/16 (20.6)	4300 (296)	2800 (192)	3500 (241)
1/2	1/2	-LM-FR8-NS8	1.45 (36.8)	1.45 (36.8)	0.75 (19.1)	0.40 (10.2)	13/16 (20.6)	4300 (296)	2800 (192)	3500 (241)

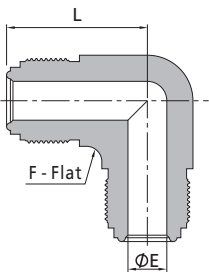

FR Body Union Elbow							
FR Size (in.)	Basic Ordering Number	Dimensions, in. (mm)			Working Pressure, psig (bar)		
		L	E	F	6L	CU	NI
1/8	-LU-FR2	0.89 (22.6)	0.09 (2.3)	7/16 (11.1)	11200 (772)	7200 (496)	9000 (620)
1/4	-LU-FR4	1.07 (27.2)	0.18 (4.6)	1/2 (12.7)	10000 (690)	6400 (440)	8000 (551)
1/2	-LU-FR8	1.45 (36.8)	0.40 (10.2)	13/16 (20.6)	4300 (296)	2800 (192)	3500 (241)
3/4	-LU-FR12	1.92 (48.8)	0.62 (15.7)	1 1/4 (31.8)	3700 (254)	2400 (165)	3000 (206)
1	-LU-FR16	2.00 (50.8)	0.87 (22.1)	1 11/16 (42.9)	3000 (206)	1900 (130)	2400 (165)

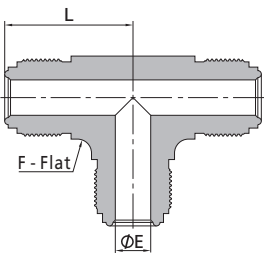

FR Body Union Tee							
FR Size (in.)	Basic Ordering Number	Dimensions, in. (mm)			Working Pressure, psig (bar)		
		L	E	F	6L	CU	NI
1/8	-TTT-FR2	0.89 (22.6)	0.09 (2.3)	7/16 (11.1)	11200 (772)	7200 (496)	9000 (620)
1/4	-TTT-FR4	1.07 (27.2)	0.18 (4.6)	1/2 (12.7)	10000 (690)	6400 (440)	8000 (551)
1/2	-TTT-FR8	1.45 (36.8)	0.40 (10.2)	13/16 (20.6)	4300 (296)	2800 (192)	3500 (241)
3/4	-TTT-FR12	1.92 (48.8)	0.62 (15.7)	1 1/4 (31.8)	3700 (254)	2400 (165)	3000 (206)
1	-TTT-FR16	2.00 (50.8)	0.87 (22.1)	1 11/16 (42.9)	3000 (206)	1900 (130)	2400 (165)

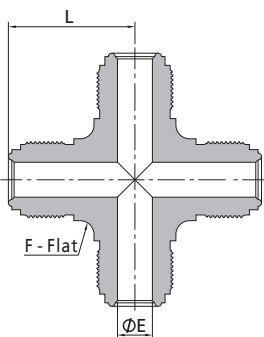

FR Body Union Cross							
FR Size (in.)	Basic Ordering Number	Dimensions, in. (mm)			Working Pressure, psig (bar)		
		L	E	F	6L	CU	NI
1/8	-C-FR2	0.89 (22.6)	0.09 (2.3)	7/16 (11.1)	11200 (772)	7200 (496)	9000 (620)
1/4	-C-FR4	1.07 (27.2)	0.18 (4.6)	1/2 (12.7)	10000 (690)	6400 (440)	8000 (551)
1/2	-C-FR8	1.45 (36.8)	0.40 (10.2)	13/16 (20.6)	4300 (296)	2800 (192)	3500 (241)
3/4	-C-FR12	1.92 (48.8)	0.62 (15.7)	1 1/4 (31.8)	3700 (254)	2400 (165)	3000 (206)
1	-C-FR16	2.00 (50.8)	0.87 (22.1)	1 11/16 (42.9)	3000 (206)	1900 (130)	2400 (165)

Welded Glands

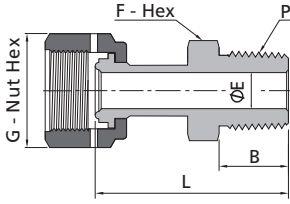

FR Welded Gland to Male NPT										
FR Size (in.)	P-NPT Size	Basic Ordering Number	Dimensions, in. (mm)					Working Pressure, psig (bar)		
			L	B	E	G	F	6L	CU	NI
1/4	1/8	-WG-FR4-NS2	1.58 (40.1)	0.38 (9.7)	0.18 (4.6)	3/4 (19.1)	7/16 (11.1)	8000 (551)	6400 (446)	8000 (551)
1/4	1/4	-WG-FR4-NS4	1.79 (45.5)	0.56 (14.2)	0.18 (4.6)	3/4 (19.1)	9/16 (14.3)	8000 (551)	6400 (446)	8000 (551)
1/2	3/8	-WG-FR8-NS6	1.89 (48.0)	0.56 (14.2)	0.40 (10.2)	1 1/16 (27.0)	11/16 (17.5)	4300 (296)	2800 (192)	3500 (241)
1/2	1/2	-WG-FR8-NS8	2.09 (53.1)	0.75 (19.1)	0.40 (10.2)	1 1/16 (27.0)	7/8 (22.2)	4300 (296)	2800 (192)	3500 (241)

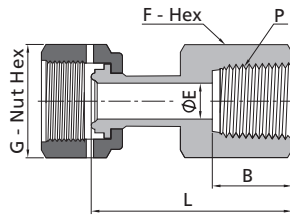

FR Welded Gland to Female NPT										
FR Size (in.)	P-NPT Size	Basic Ordering Number	Dimensions, in. (mm)					Working Pressure, psig (bar)		
			L	B	E	G	F	6L	CU	NI
1/4	1/4	-WG-FR4-FNS4	1.77 (45.0)	0.59 (15.0)	0.18 (4.6)	3/4 (19.1)	3/4 (19.1)	6600 (454)	5200 (458)	6600 (454)
1/2	3/8	-WG-FR8-FNS6	1.95 (49.5)	0.59 (15.0)	0.40 (10.2)	1 1/16 (27.0)	7/8 (22.2)	4300 (296)	2800 (192)	3500 (241)
1/2	1/2	-WG-FR8-FNS8	2.18 (55.4)	0.78 (19.8)	0.40 (10.2)	1 1/16 (27.0)	1 1/16 (27.0)	4300 (296)	2800 (192)	3500 (241)

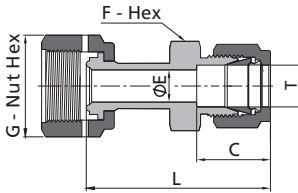

FR Welded Gland to Tube Fitting										
FR Size (in.)	T-Tube O.D. (in.)	Basic Ordering Number	Dimensions, in. (mm)					Working Pressure, psig (bar)		
			L ^①	C	E	G	F	6L	CU	NI
1/4	1/4	-WG-FR4-FL4	1.94 (49.3)	0.60 (15.2)	0.18 (4.6)	3/4 (19.1)	1/2 (12.7)	8000 (551)	6400 (440)	8000 (551)
1/4	3/8	-WG-FR4-FL6	1.97 (50.0)	0.66 (16.8)	0.18 (4.6)	3/4 (19.1)	5/8 (15.9)	6500 (447)	5200 (358)	6500 (447)
1/2	1/2	-WG-FR8-FL8	2.23 (56.6)	0.90 (22.9)	0.40 (10.2)	1 1/16 (27.0)	13/16 (20.6)	4300 (296)	2800 (192)	3500 (241)

① Dimension L is with FITOK nuts finger-tight.

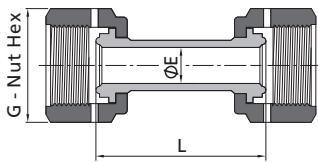

FR Welded Gland Union							
FR Size (in.)	Basic Ordering Number	Dimensions, in. (mm)			Working Pressure, psig (bar)		
		L	E	G	6L	CU	NI
1/4	-WG-FR4	1.71 (43.4)	0.18 (4.6)	3/4 (19.1)	8000 (551)	6400 (440)	8000 (551)
1/2	-WG-FR8	1.84 (46.7)	0.40 (10.2)	1 1/16 (27.0)	4300 (296)	2800 (192)	3500 (241)

Female Elbows

Basic ordering number: -LWG-FR4

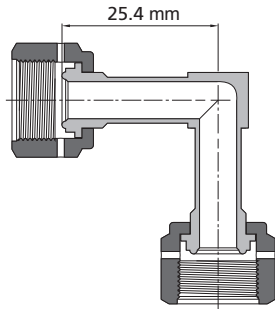

Female Tees

Basic ordering number: -TWG-FR4

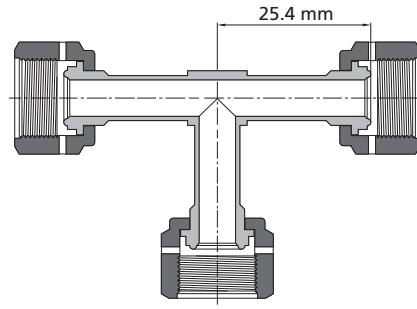

Nuts

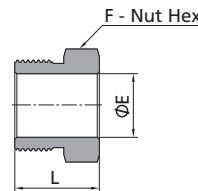
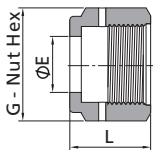

Female Nut				
FR Size (in.)	Basic Ordering Number	Dimensions, in. (mm)		
		L	E	G
1/8	-N-FR2	0.53 (13.5)	0.21 (5.3)	7/16 (11.1)
1/4	-N-FR4	0.81 (20.6)	0.36 (9.1)	3/4 (19.1)
1/2	-N-FR8	0.88 (22.4)	0.61 (15.5)	1 1/16 (27.0)
5/8	-N-FR10	0.88 (22.4)	0.74 (18.8)	1 3/16 (30.2)
3/4	-N-FR12	1.12 (28.4)	0.89 (22.6)	1 1/2 (38.1)
1	-N-FR16	1.34 (34.0)	1.20 (30.5)	1 3/4 (44.5)

Male Nut				
FR Size (in.)	Basic Ordering Number	Dimensions, in. (mm)		
		L	E	F
1/8	-MN-FR2	0.50 (12.7)	0.21 (5.3)	3/8 (9.5)
1/4	-MN-FR4	0.71 (18.0)	0.36 (9.1)	5/8 (15.9)
1/2	-MN-FR8	0.81 (20.6)	0.61 (15.5)	15/16 (23.8)
5/8	-MN-FR10	0.81 (20.6)	0.74 (18.8)	1 1/16 (27.0)
3/4	-MN-FR12	1.00 (25.4)	0.89 (22.6)	1 5/16 (33.3)
1	-MN-FR16	1.19 (30.2)	1.20 (30.5)	1 5/8 (41.3)

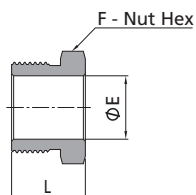

Short Male Nut				
FR Size (in.)	Basic Ordering Number	Dimensions, in. (mm)		
		L	E	F
1/4	-MN-FR4-0.54	0.54 (13.7)	0.36 (9.1)	5/8 (15.9)
1/4	-MN-FR4-0.65	0.65 (16.5)	0.36 (9.1)	5/8 (15.9)

For use with Gland to Short Tube Butt Weld

Split-Nut Assemblies

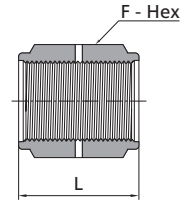
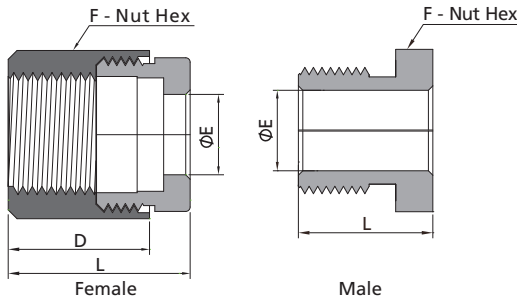

Split-Nut Assemblies						
FR Size (in.)	Split Nut Type	Basic Ordering Number	Dimensions, in. (mm)			
			L	E	F	D
1/4	Female	-N-FR4-SN	0.81 (20.6)	0.36 (9.1)	3/4 (19.1)	0.63 (16.0)
1/4	Male	-MN-FR4-SN	0.60 (15.2)	0.36 (9.1)	5/8 (15.9)	-

Coupling			
FR Size (in.)	Basic Ordering Number	Dimensions, in. (mm)	
		L	F
1/8	-BC-FR2	0.66 (16.8)	7/16 (11.1)
1/4	-BC-FR4	1.19 (30.2)	3/4 (19.1)
1/2	-BC-FR8	1.31 (33.3)	1 1/16 (27.0)
3/4	-BC-FR12	1.68 (42.7)	1 1/2 (38.1)
1	-BC-FR16	2.04 (51.8)	1 3/4 (44.5)

Plugs

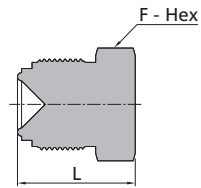

Plug			
FR Size (in.)	Basic Ordering Number	Dimensions, in. (mm)	
		L	F
1/8	-PG-FR2	0.68 (17.3)	3/8 (9.5)
1/4	-PG-FR4	0.92 (23.4)	5/8 (15.9)
1/2	-PG-FR8	1.08 (27.4)	15/16 (23.8)
3/4	-PG-FR12	1.43 (36.3)	1 5/16 (33.3)
1	-PG-FR16	1.52 (38.6)	1 5/8 (41.3)

Caps

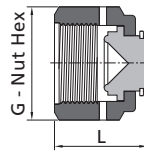

Cap			
FR Size (in.)	Basic Ordering Number	Dimensions, in. (mm)	
		L	G
1/8	-CP-FR2	0.63 (16.0)	7/16 (11.1)
1/4	-CP-FR4	0.94 (23.9)	3/4 (19.1)
1/2	-CP-FR8	1.01 (25.6)	1 1/16 (27.0)
3/4	-CP-FR12	1.29 (32.8)	1 1/2 (38.1)
1	-CP-FR16	1.54 (39.1)	1 3/4 (44.5)

Plugs with Lanyard

- ⊙ Lanyard material: 304 SS.
- ⊙ Lanyard length: 15.2 cm.



Plug with Lanyard			
FR Size (in.)	Basic Ordering Number	Dimensions, in. (mm)	
		L	F
1/4	-PG-FR4-BP	0.92 (23.4)	5/8 (15.9)
1/2	-PG-FR8-BP	1.08 (27.4)	15/16 (23.8)

Caps with Lanyard

- ⊙ Lanyard material: 304 SS.
- ⊙ Lanyard length: 15.2 cm.



Cap with Lanyard			
FR Size (in.)	Basic Ordering Number	Dimensions, in. (mm)	
		L	G
1/4	-CP-FR4-BP	0.94 (23.9)	3/4 (19.1)
1/2	-CP-FR8-BP	1.01 (25.6)	1 1/16 (27.0)

Flow Restrictors

- Working pressure up to: 10,000 psig (690 bar)

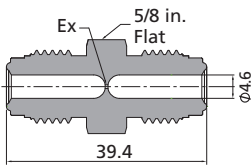

FR Body to Male FR	
Ex, in. (mm)	Ordering Number
0.015 (0.381)	6LV-R-FR4-015
0.017 (0.432)	6LV-R-FR4-017
0.020 (0.508)	6LV-R-FR4-020
0.023 (0.584)	6LV-R-FR4-023
0.025 (0.635)	6LV-R-FR4-025
0.026 (0.660)	6LV-R-FR4-026
0.027 (0.686)	6LV-R-FR4-027
0.030 (0.762)	6LV-R-FR4-030
0.035 (0.889)	6LV-R-FR4-035
0.040 (1.016)	6LV-R-FR4-040
0.045 (1.143)	6LV-R-FR4-045
0.050 (1.270)	6LV-R-FR4-050
0.055 (1.397)	6LV-R-FR4-055
0.060 (1.529)	6LV-R-FR4-060
0.065 (1.651)	6LV-R-FR4-065
0.070 (1.778)	6LV-R-FR4-070
0.075 (1.905)	6LV-R-FR4-075
0.080 (2.032)	6LV-R-FR4-080
0.085 (2.159)	6LV-R-FR4-085
0.090 (2.286)	6LV-R-FR4-090
0.093 (2.362)	6LV-R-FR4-093
0.095 (2.413)	6LV-R-FR4-095
0.100 (2.540)	6LV-R-FR4-100

Locking Device

- To help prevent unintentional disassembly of FR connections.
- Used for FITOK FR metal gasket face seal assemblies with standard male and female nuts.



Locking Device	
FR Size (in.)	Ordering Number
1/4	S4-FR4-LD
1/2	S4-FR8-LD

Gaskets

- Copper gaskets are unplated.
- Unplated SS gaskets and Nickel gaskets are electropolished.
- If Silver-plated SS or Nickel gaskets are required, please delete the suffix of "-UP" from the ordering number.

Nonretained

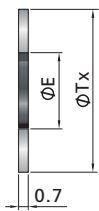

Unplated (UP)			
FR Size (in.)	Basic Ordering Number	Dimensions, in. (mm)	
		Tx	E
1/8	-GT-FR2-UP	0.26 (6.6)	0.09 (2.3)
1/4	-GT-FR4-UP	0.47 (11.9)	0.22 (5.6)
1/2	-GT-FR8-UP	0.78 (19.8)	0.44 (11.2)
5/8	-GT-FR10-UP	0.91 (23.1)	0.58 (14.7)
3/4	-GT-FR12-UP	1.14 (29.0)	0.66 (16.8)
1	-GT-FR16-UP	1.40 (35.6)	0.89 (22.6)

Gaskets are used without retainers.

Gasket Retainer Assemblies

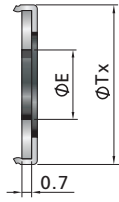

Unplated (UP)			
FR Size (in.)	Basic Ordering Number	Dimensions, mm	
		Tx	E
1/4	-GT-FR4-A-UP	0.50 (12.7)	0.24 (6.1)
1/2	-GT-FR8-A-UP	0.79 (20.1)	0.44 (11.2)
3/4	-GT-FR12-A-UP	1.14 (29.0)	0.66 (16.8)
1	-GT-FR16-A-UP	1.40 (35.6)	0.89 (22.6)

1. Gaskets are used with retainers.
2. Retainer material is 316L SS.
3. Retainers are available in different colors, please contact FITOK Group for more details.

Side-load Retainer

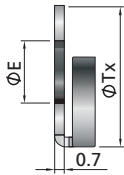

Unplated (UP)			
FR Size (in.)	Basic Ordering Number	Dimensions, in. (mm)	
		Tx	E
1/4	-GT-FR4-AS-UP	0.45 (11.4)	0.24 (6.1)
1/2	-GT-FR8-AS-UP	0.75 (19.1)	0.43 (11.0)

1. Gaskets are only available in 316L SS and Nickel.
2. Silver-plated gaskets are not available.

Blind



Unplated (UP)		
FR Size (in.)	Basic Ordering Number	Dimensions, in. (mm)
		Tx
1/8	-GT-FR2-B-UP	0.26 (6.6)
1/4	-GT-FR4-B-UP	0.47 (11.9)
1/2	-GT-FR8-B-UP	0.78 (19.8)
5/8	-GT-FR10-B-UP	0.91 (23.1)
3/4	-GT-FR12-B-UP	1.14 (29.0)
1	-GT-FR16-B-UP	1.40 (35.6)

Blind gasket retainer assemblies are available, please contact FITOK Group for more details.

Snubber

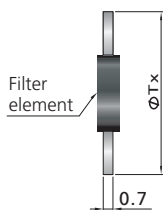

Unplated (UP)		
FR Size (in.)	Basic Ordering Number	Dimensions, mm
		Tx
1/4	-GT-FR4-UP-**M	0.47 (11.9)
1/2	-GT-FR8-UP-**M	0.78 (19.8)
3/4	-GT-FR12-UP-**M	1.14 (29.0)
1	-GT-FR16-UP-**M	1.40 (35.6)

1. Add the designator of filter element precision accuracy as a suffix to the basic ordering number to get the complete ordering number.
Example: For 1/4" 316L SS snubber with filter element precision accuracy of 5 μm, the ordering number is 6L-GT-FR4-UP-5M.

Knurled Gasket

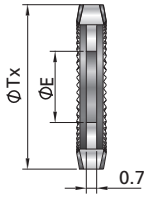

Unplated (UP)			
FR Size (in.)	Basic Ordering Number	Dimensions, in.(mm)	
		Tx	E
1/4	-GT-FR4-KN-A-UP	0.5(12.7)	0.22(5.5)

- Used for nut loose prevention caused by vibration.
- General 316L SS or Nickle gasket is assembled by 1/8 turn, but its installation method is 3/8 turn.

High-Flow Connections - "H" Type FR

"H" type FR connections with high flow capacity are compatible with regular FR connections. Gasket retainer assemblies are recommended to minimize flow resistance.

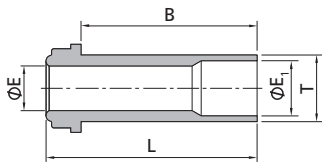

HFR Gland to Tube Butt Weld										
FR Size (in.)	T-Tube O.D. (in.)	Nominal Wall Thickness (in.)	Basic Ordering Number	Dimensions, in. (mm)				Working Pressure, psig (bar)		
				L	B	E	E ₁	6L	CU	NI
1/4	3/8	0.035	-G-HFR4-TB6-0.60	0.60 (15.2)	0.41 (10.4)	0.25 (6.4)	0.31 (7.9)	3300 (227)	3300 (227)	3300 (227)
1/4	3/8	0.035	-G-HFR4-TB6-1.19	1.19 (30.2)	1.00 (25.4)	0.25 (6.4)	0.31 (7.9)	3300 (227)	3300 (227)	3300 (227)
1/4	3/8	0.035	-G-HFR4-TB6-1.31	1.31 (33.3)	1.12 (28.4)	0.25 (6.4)	0.31 (7.9)	3300 (227)	3300 (227)	3300 (227)

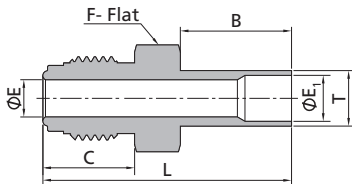

HFR Body to Tube Butt Weld												
FR Size (in.)	T-Tube O.D. (in.)	Basic Ordering Number	Dimensions, in. (mm)						Working Pressure, psig (bar)			
			L	B	C	E	E ₁	F	6L	CU	NI	
1/4	3/8	-CW-HFR4-TB6	1.68 (42.7)	0.75 (19.1)	0.62 (15.7)	0.25 (6.4)	0.31 (7.9)	5/8 (15.9)	3300 (227)	3300 (227)	3300 (227)	

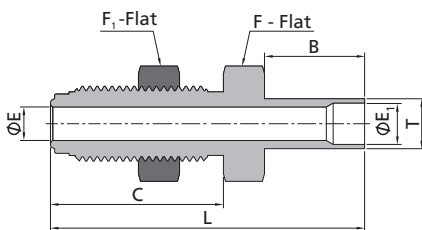

HFR Bulkhead Body to Tube Butt Weld														
FR Size (in.)	T-Tube O.D. (in.)	Basic Ordering Number	Dimensions, in. (mm)								Working Pressure, psig (bar)			
			L	B	C	E	E ₁	F	F ₁	Panel Hole Dia	Max. Panel Thickness Hole Dia	6L	CU	NI
1/4	3/8	-BW-HFR4-TB6	2.36 (59.9)	0.75 (19.1)	1.30 (33.0)	0.31 (7.9)	0.25 (6.4)	3/4 (19.1)	3/4 (19.1)	19/32 (15.0)	0.44 (11.2)	3300 (227)	3300 (227)	3300 (227)

F-37 Face Seal Fittings

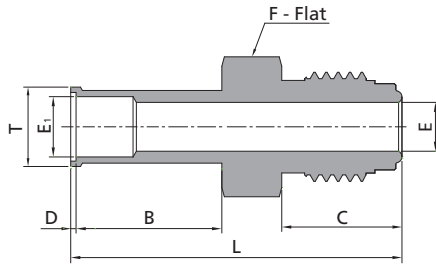

HFR Body to Automatic Tube Weld

FR Size (in.)	Tube Size (in.)	Basic Ordering Number	Dimensions, in. (mm)									Working Pressure, psig (bar)		
			L	B	C	D	E	E ₁	F	T	6L	CU	NI	
1/4	3/8	-AW-HFR4-TB6	1.71 (43.4)	0.75 (19.1)	0.62 (15.7)	0.03 (0.8)	0.25 (6.4)	0.31 (7.9)	5/8 (15.9)	0.41 (10.4)	3300 (227)	3300 (227)	3300 (227)	

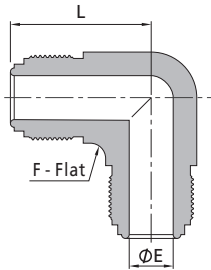

HFR Body Union Elbow

FR Size (in.)	Basic Ordering Number	Dimensions, in. (mm)			Working Pressure, psig (bar)		
		L	E	F	6L	CU	NI
1/4	-LU-HFR4	1.07 (27.2)	0.25 (6.4)	1/2 (12.7)	10000 (690)	6400 (440)	8000 (551)

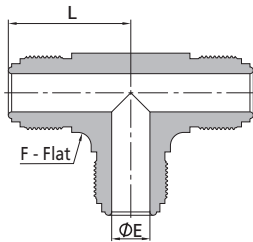

HFR Body Union Tee

FR Size (in.)	Basic Ordering Number	Dimensions, in. (mm)			Working Pressure, psig (bar)		
		L	E	F	6L	CU	NI
1/4	-TTT-HFR4	1.07 (27.2)	0.25 (6.4)	1/2 (12.7)	10000 (690)	6400 (440)	8000 (551)

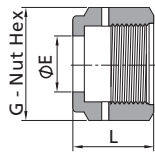

HFR Female Nut

FR Size (in.)	Basic Ordering Number	Dimensions, in. (mm)		
		L	E	G
1/4	-N-HFR4-9.9	0.81 (20.6)	0.39 (9.9)	3/4 (19.1)
1/4	-N-HFR4-11.7	0.81 (20.6)	0.46 (11.7)	3/4 (19.1)

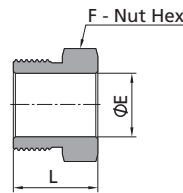

HFR Male Nut

FR Size (in.)	Basic Ordering Number	Dimensions, in. (mm)		
		L	E	F
1/4	-MN-HFR4	0.71 (18.0)	0.39 (9.9)	5/8 (15.9)

Face Seal Fittings

TFO Series L-ring Face Seal Fittings

Features

- ⦿ Reduced internal entrapment
- ⦿ Lubricant-free L-ring seal
- ⦿ Controlled L-ring extrusion to prevent over-tightening
- ⦿ Butt weld connection to ensure the system unhindered
- ⦿ Standard surface roughness finished to an average of Ra 20 $\mu\text{in.}$ (0.51 μm)
- ⦿ Each fitting marked with size, material and heat number



Technical Data

- ⦿ Sizes range from 1/4" to 1"
- ⦿ Materials:

Material	Bar Stock	Designator
316 SS	ASTM A276, ASME SA479	SS
316L SS		6L

- ⦿ Working Pressure @ 100°F (37°C):

Tube OD.	Working Pressure psig (bar)
1/4 in.	2500 (172)
1/2 in.	2000 (137)
3/4 in.	1500 (103)
1 in.	
12 mm	2000 (137)

- ⦿ Working Temperature:
Temperature ranges for TFO fittings are restricted by the L-ring materials.

Material	Designator	Working Temperature
PTFE	T	- 50°F to 450°F (- 45°C to 232°C)

Testing

Every TFO fitting is Helium leak tested to a maximum allowable leak rate of 4×10^{-9} std cm³/s.

Ordering Information

- ⦿ Each component can be ordered separately.
 - ⦿ Add the material designator as a prefix, cleaning and packaging code as a suffix to the basic ordering number to get the complete ordering number.
 - ⦿ Cleaning and Packaging
 - a. FC-01 Standard Cleaning and Packaging for general industrial procedures. No suffix is needed.
 - b. FC-02 Special Cleaning and Packaging, to ensure compliance with product cleanliness requirement as stated in ASTM G93 Level C. Add "-F2" as a suffix when needed.
- Example: For 316L SS standard 1/4" gland with FC-02 Special Cleaning and Packaging, the ordering number is 6L-G-TFO4-TB4-F2.

Installation Instructions

1. Assemble the gland, nut and gasket as below. Finger tight the nut.

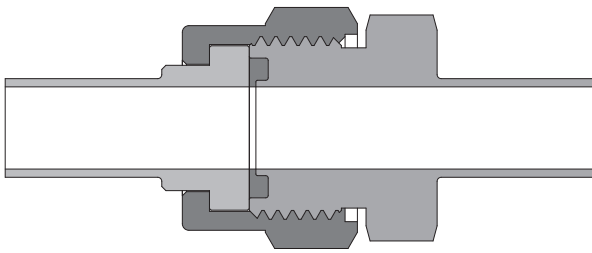

2. Tighten the nut 1/8 turn with a wrench while holding the fitting body steady.

Cautions

- ⦿ Dimensions are for reference only and are subject to change.
- ⦿ Inspect the O-ring each time the groove housing is dismantled.
- ⦿ Before welding the body, the L-ring should be removed to prevent possible damages.
- ⦿ Tungsten Inert Gas Welding (TIG) is recommended.
- ⦿ Do not loosen or tighten fittings when system is pressurized.

Glands

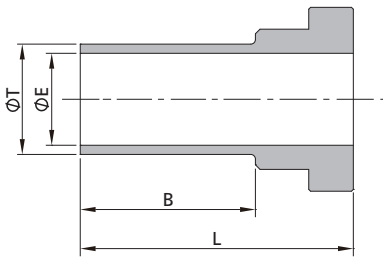

T-Tube O.D. (in.)	Wall Thickness (in.)	Basic Ordering Number	Dimensions, in. (mm)		
			L	B	E
1/4	0.035	-G-TFO4-TB4	0.67 (17.0)	0.25 (6.4)	0.18 (4.6)
1/4	0.035	-G-TFO4-TB4-12	1.17 (29.7)	0.75 (19.1)	0.18 (4.6)
1/2	0.049	-G-TFO8-TB8	1.17 (29.7)	0.75 (19.1)	0.40 (10.2)
1/2	0.065	-G-TFO8-TB8×0.065	1.17 (29.7)	0.75 (19.1)	0.37 (9.4)
3/4	0.065	-G-TFO12-TB12	1.24 (31.5)	0.75 (19.1)	0.62 (15.7)
1	0.065	-G-TFO16-TB16	1.45 (36.8)	0.96 (24.4)	0.87 (22.1)

T-Tube O.D. (mm)	Wall Thickness (mm)	Basic Ordering Number	Dimensions, in. (mm)		
			L	B	E
12	1	-G-TFO8-MTB12	1.17 (29.7)	0.75 (19.1)	0.39 (10.0)

Nuts

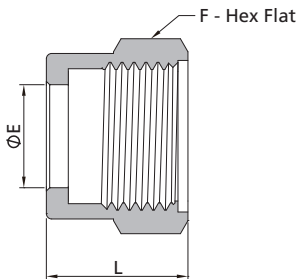

Basic Ordering Number	Dimensions, in. (mm)		
	L	E	F
-N-TFO4	0.75 (19.1)	0.39 (9.9)	11/16 (17.5)
-N-TFO8	0.84 (21.3)	0.61 (15.5)	1 (25.4)
-N-TFO12	0.90 (22.9)	0.94 (23.9)	1 1/2 (38.1)
-N-TFO16	0.90 (22.9)	1.25 (31.8)	1 3/4 (44.5)

Tube Butt Weld Bodies

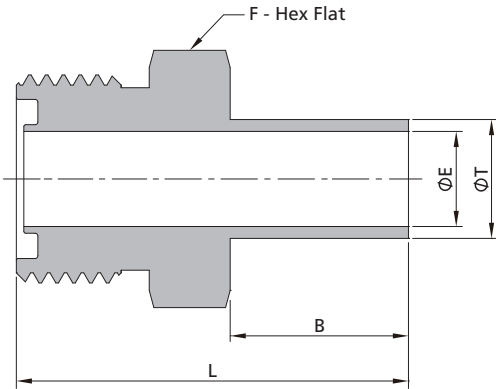

T-Tube OD. (in.)	Wall Thickness (in.)	Basic Ordering Number	Dimensions, in. (mm)			
			L	B	E	F
1/4	0.035	-CW-TFO4-TB4	1.03 (26.2)	0.25 (6.4)	0.18 (4.6)	5/8 (15.9)
1/4	0.035	-CW-TFO4-TB4-12	1.53 (38.9)	0.75 (19.1)	0.18 (4.6)	5/8 (15.9)
1/2	0.049	-CW-TFO8-TB8	1.65 (41.9)	0.75 (19.1)	0.40 (10.2)	15/16 (23.8)
1/2	0.065	-CW-TFO8-TB8×0.065	1.65 (41.9)	0.75 (19.1)	0.37 (9.4)	15/16 (23.8)
3/4	0.065	-CW-TFO12-TB12	1.75 (44.4)	0.75 (19.1)	0.62 (15.7)	1 5/16 (33.3)
1	0.065	-CW-TFO16-TB16	1.99 (50.5)	0.96 (24.4)	0.87 (22.1)	1 5/8 (47.6)

T-Tube OD. (mm)	Wall Thickness (mm)	Basic Ordering Number	Dimensions, in. (mm)			
			L	B	E	F
12	1	-CW-TFO8-MTB12	1.65 (41.9)	0.75 (19.1)	0.39 (10.0)	15/16 (23.8)

L-ring Seal

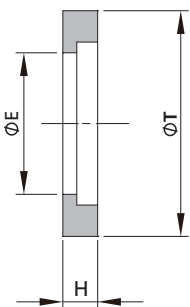

Basic Ordering Number	Dimensions, in. (mm)		
	T	E	H
-GT-TFO4	0.38 (9.6)	0.18 (4.6)	0.07 (1.8)
-GT-TFO8	0.64 (16.2)	0.40 (10.2)	0.10 (2.5)
-GT-TFO12	0.92 (23.4)	0.62 (15.7)	0.10 (2.5)
-GT-TFO16	1.30 (33.0)	0.87 (22.1)	0.14 (3.6)

Add the L-ring material designator in page F-38 as a prefix to the basic ordering number to get the complete ordering number.

Example: T-GT-TFO4

Face Seal Fittings

FO Series O-ring Face Seal Fittings

Features

- ⦿ O-ring seal to provide perfect leak-tight service for working conditions from critical vacuum to high pressure
- ⦿ O-ring contained completely for maximum efficiency
- ⦿ Smooth finish on gland face to ensure positive seal
- ⦿ Test ports at nut for easy leak testing
- ⦿ Easy installation and maintenance
- ⦿ Silver-plated female threads
- ⦿ Standard surface roughness finished to an average of Ra 10 μm . (0.25 μm)
- ⦿ Every gland and body marked with size, material and heat number



Technical Data

- ⦿ Sizes range from 1/8" to 1"
- ⦿ Thread Specifications:

Thread Type	Specification
NPT	ASME B1.20.1, SAE AS71051
Unified (SAE)	ASME B1.1, SAE J475

- ⦿ Materials:

Material	Bar Stock	Forging	Designator
316 SS	ASTM A276, ASME SA479	ASTM A182, ASME SA182	SS
316L SS			6L

- ⦿ Working Pressure:

Working pressures shown in the Catalog are calculated according to ASME B31.3 and B31.1 at ambient temperature.

- ⦿ Working Temperature:

Temperature ranges for FO fittings are restricted by the O-ring materials.

Material	Designator	Working Temperature
Fluorocarbon FKM (70 durometer)	VI7	-10°F to 400°F (-23°C to 204°C)
Fluorocarbon FKM (90 durometer)	VI9	-10°F to 400°F (-23°C to 204°C)
PTFE	T	-50°F to 450°F (-45°C to 232°C)
Buna N (70 durometer)	BN7	-10°F to 250°F (-23°C to 121°C)
Perfluoroelastomer	Z	-10°F to 550°F (-23°C to 287°C)
Ethylene Propylene	E	-50°F to 300°F (-45°C to 148°C)

Fluorocarbon FKM of 90 durometer is used for SAE/IMS threads end.

Testing

Every FO fitting is Helium leak tested to a maximum allowable leak rate of 4×10^{-9} std cm³/s.

Ordering Information

- ⦿ Each component can be ordered separately.
- ⦿ The FO body is supplied with O-rings of fluorocarbon FKM (70 durometer).
- ⦿ Add the material designator as a prefix, cleaning and packaging code as a suffix to the basic ordering number to get the complete ordering number.
- ⦿ Cleaning and Packaging
 - a. FC-01 Standard Cleaning and Packaging for general industrial procedures. No suffix is needed.
 - b. FC-02 Special Cleaning and Packaging, to ensure compliance with product cleanliness requirement as stated in ASTM G93 Level C. Add "-F2" as a suffix when needed.

Example: For 316L SS standard 1/4" gland with FC-02 Special Cleaning and Packaging, the ordering number is 6L-G-FO4-TB4-F2.

Installation Instructions

1. Assemble the gland, nut, O-ring and body as below. Finger tight the nut.

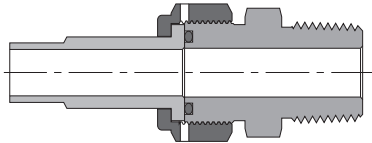

2. Tighten the nut 1/8 - 1/4 turn with a wrench while holding the fitting body steady, until there is a sharp rise in torque.

Cautions

- ⦿ Dimensions are for reference only and are subject to change.
- ⦿ Inspect the O-ring each time the groove housing is dismantled.
- ⦿ Before welding the body, the O-ring should be removed to prevent possible damages.
- ⦿ Tungsten Inert Gas Welding (TIG) is recommended.
- ⦿ Do not loosen or tighten fittings when system is pressurized.

Glands

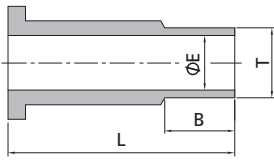

FO Gland to Tube Butt Weld						
FO Size (in.)	T-Tube O.D. (in.)	Basic Ordering Number	Dimensions, in. (mm)			Working Pressure psig (bar)
			L	B	E	
1/4	1/8	-G-FO4-TB2	0.77 (19.6)	0.28 (7.1)	0.06 (1.5)	11200 (771)
1/4	1/4	-G-FO4-TB4	1.12 (28.4)	0.41 (10.4)	0.12 (3.0)	11200 (771)
1/2	1/4	-G-FO8-TB4	0.91 (23.1)	0.41 (10.4)	0.12 (3.0)	11200 (771)
1/2	3/8	-G-FO8-TB6	0.84 (21.3)	0.41 (10.4)	0.23 (5.8)	8200 (564)
1/2	1/2	-G-FO8-TB8	1.06 (26.9)	0.50 (12.7)	0.33 (8.4)	7500 (516)

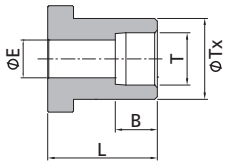

FO Gland to Tube Socket Weld							
FO Size (in.)	T-Tube O.D. (in.)	Basic Ordering Number	Dimensions, in. (mm)				Working pressure psig (bar)
			L	B	E	Tx	
1/8	1/8	-G-FO2-TS2	0.77 (19.6)	0.10 (2.5)	0.09 (2.3)	0.38 (9.7)	15400 (1061)
1/4	1/4	-G-FO4-TS4	0.77 (19.6)	0.28 (7.1)	0.18 (4.6)	0.38 (9.7)	6800 (468)
3/8	3/8	-G-FO6-TS6	0.81 (20.6)	0.31 (7.9)	0.28 (7.1)	0.60 (15.2)	8100 (558)
1/2	1/2	-G-FO8-TS8	0.81 (20.6)	0.38 (9.7)	0.40 (10.2)	0.60 (15.2)	3000 (206)
3/4	3/4	-G-FO12-TS12	0.94 (23.9)	0.44 (11.2)	0.62 (15.7)	0.92 (23.4)	3700 (255)
1	1	-G-FO16-TS16	0.98 (24.9)	0.62 (15.7)	0.87 (22.1)	1.19 (30.2)	3000 (206)

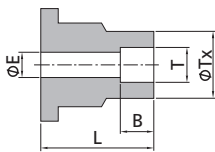

FO Gland to Tube Socket Weld Reducing							
FO Size (in.)	T-Tube O.D. (in.)	Basic Ordering Number	Dimensions, in. (mm)				Working pressure psig (bar)
			L	B	E	Tx	
1/4	1/8	-G-FO4-TS2	0.77 (19.6)	0.10 (2.5)	0.09 (2.3)	0.29 (7.4)	12600 (868)
1/2	1/4	-G-FO8-TS4	0.81 (20.6)	0.28 (7.1)	0.18 (4.6)	0.48 (12.2)	10700 (737)

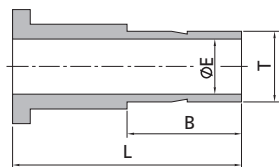

FO Gland to Tube Port						
FO Size (in.)	T-Tube O.D. (in.)	Basic Ordering Number	Dimensions, in. (mm)			Working Pressure psig (bar)
			L	B	E	
1/4	1/4	-G-FO4-FT4	1.31 (33.3)	0.64 (16.3)	0.18 (4.6)	10200 (702)
1/2	3/8	-G-FO8-FT6	1.38 (35.1)	0.70 (17.8)	0.27 (6.8)	6500 (447)
1/2	1/2	-G-FO8-FT8	1.62 (41.1)	0.96 (24.4)	0.37 (9.3)	6700 (461)
3/4	3/4	-G-FO12-FT12	1.80 (45.7)	1.02 (25.9)	0.58 (14.7)	5800 (399)
1	1	-G-FO16-FT16	2.05 (52.1)	1.30 (33.0)	0.80 (20.3)	4700 (323)

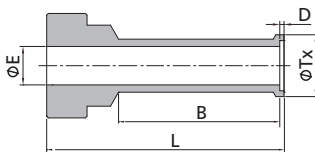

FO Gland to Automatic Tube Weld									
FO Size (in.)	Tube O.D. (in.)	Wall Thickness (in.)	Basic Ordering Number	Dimensions, in. (mm)					Working pressure psig (bar)
				L	B	D	E	Tx	
1/4	1/4	0.035	-G-FO4-TB4A	1.12 (28.4)	0.78 (19.8)	0.02 (0.5)	0.18 (4.6)	0.29 (7.4)	5100 (351)
1/2	3/8	0.035	-G-FO8-TB6A	1.13 (28.7)	0.79 (20.0)	0.03 (0.8)	0.31 (7.9)	0.41 (10.4)	3300 (227)
1/2	1/2	0.049	-G-FO8-TB8A	1.14 (29.0)	0.80 (20.3)	0.04 (1.0)	0.40 (10.2)	0.55 (14.0)	3500 (241)
3/4	3/4	0.049	-G-FO12-TB12A	1.20 (30.5)	0.80 (20.3)	0.04 (1.0)	0.65 (16.5)	0.80 (20.3)	2200 (151)
1	1	0.065	-G-FO16-TB16A	1.41 (35.8)	1.00 (25.4)	0.04 (1.0)	0.87 (22.1)	1.06 (26.9)	2200 (151)

Welded Glands

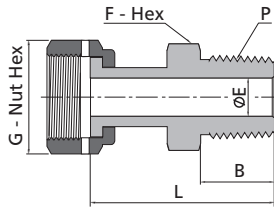

FO Welded Gland to Male NPT								
FO Size (in.)	P-NPT Size	Basic Ordering Number	Dimensions, in. (mm)					Working Pressure psig (bar)
			L	B	E	G	F	
1/4	1/4	-WG-FO4-NS4	1.59 (40.4)	0.56 (14.2)	0.18 (4.6)	11/16 (17.5)	5/8 (15.9)	9800 (675)
1/2	3/8	-WG-FO8-NS6	1.67 (42.4)	0.56 (14.2)	0.40 (10.2)	1 (25.4)	15/16 (23.8)	5600 (385)
1/2	1/2	-WG-FO8-NS8	1.87 (47.5)	0.75 (19.1)	0.40 (10.2)	1 (25.4)	15/16 (23.8)	5600 (385)
3/4	3/4	-WG-FO12-NS12	2.03 (51.6)	0.75 (19.1)	0.62 (15.7)	1 1/2 (38.1)	1 1/16 (27.0)	3900 (268)
1	1	-WG-FO16-NS16	2.36 (59.9)	0.94 (23.9)	0.87 (22.1)	1 3/4 (44.5)	1 5/8 (41.3)	2900 (199)

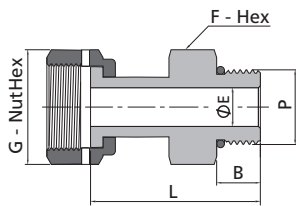

FO Welded Gland to SAE/MS Thread								
FO Size (in.)	P-SAE/MS Thread Size	Basic Ordering Number	Dimensions, in. (mm)					Working Pressure psig (bar)
			L	B	E	G	F	
1/4	7/16-20	-WG-FO4-ST7	1.54 (39.1)	0.36 (9.1)	0.18 (4.6)	11/16 (17.5)	9/16 (14.3)	4500 (310)
1/2	9/16-18	-WG-FO8-ST9	1.64 (41.7)	0.39 (9.9)	0.40 (10.2)	1 (25.4)	11/16 (17.5)	4500 (310)
1/2	3/4-16	-WG-FO8-ST12	1.71 (43.4)	0.45 (11.2)	0.40 (10.2)	1 (25.4)	7/8 (22.2)	4500 (310)
3/4	1 1/16-12	-WG-FO12-ST17	2.07 (52.6)	0.59 (15.0)	0.62 (15.7)	1 1/2 (38.1)	1 1/4 (31.8)	3600 (248)
1	1 5/16-12	-WG-FO16-ST21	2.17 (55.1)	0.59 (15.0)	0.87 (22.1)	1 3/4 (44.5)	1 1/2 (38.1)	2900 (199)

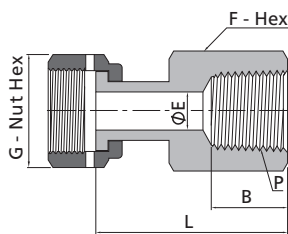

FO Welded Gland to Female NPT								
FO Size (in.)	P-NPT Size	Basic Ordering Number	Dimensions, in. (mm)					Working Pressure psig (bar)
			L	B	E	G	F	
1/4	1/4	-WG-FO4-FNS4	1.57 (39.9)	0.59 (15.0)	0.18 (4.6)	11/16 (17.5)	3/4 (19.1)	6600 (454)
1/2	3/8	-WG-FO8-FNS6	1.73 (43.9)	0.59 (15.0)	0.40 (10.2)	1 (25.4)	7/8 (22.2)	5300 (365)
1/2	1/2	-WG-FO8-FNS8	1.96 (49.8)	0.78 (19.8)	0.40 (10.2)	1 (25.4)	1 1/16 (27.0)	4900 (337)
3/4	3/4	-WG-FO12-FNS12	2.12 (53.8)	0.81 (20.6)	0.62 (15.7)	1 1/2 (38.1)	1 5/16 (33.3)	4000 (275)
1	1	-WG-FO16-FNS16	2.29 (58.2)	1.00 (25.4)	0.87 (22.1)	1 3/4 (44.5)	1 5/8 (41.3)	3000 (206)

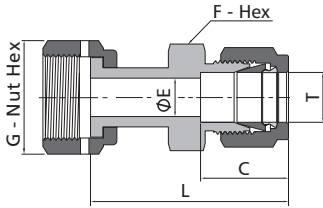

FO Welded Gland to Tube Fitting									
FO Size (in.)	T-Tube O.D. (in.)	Basic Ordering Number	Dimensions, in. (mm)					Working Pressure psig (bar)	
			L	C	E	G	F		
1/4	1/4	-WG-FO4-FL4	1.74 (44.2)	0.60 (15.2)	0.18 (4.6)	11/16 (17.5)	1/2 (12.7)	10200 (702)	
1/2	3/8	-WG-FO8-FL6	1.87 (47.5)	0.66 (16.8)	0.28 (7.1)	1 (25.4)	5/8 (15.9)	5800 (399)	
1/2	1/2	-WG-FO8-FL8	2.01 (51.1)	0.90 (22.9)	0.40 (10.2)	1 (25.4)	13/16 (20.6)	5800 (399)	
3/4	3/4	-WG-FO12-FL12	2.14 (54.4)	0.96 (24.4)	0.62 (15.7)	1 1/2 (38.1)	1 1/16 (27.0)	4000 (275)	
1	1	-WG-FO16-FL16	2.45 (62.2)	1.23 (31.2)	0.87 (22.1)	1 3/4 (44.5)	1 3/8 (34.9)	3000 (206)	

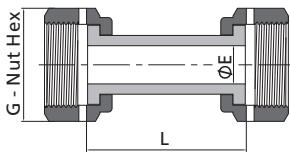

FO Welded Gland Union					
FO Size (in.)	Basic Ordering Number	Dimensions, in. (mm)			Working Pressure psig (bar)
		L	E	G	
1/4	-WG-FO4	1.42 (36.1)	0.18 (4.6)	11/16 (17.5)	10200 (702)
1/2	-WG-FO8	1.61 (40.9)	0.40 (10.2)	1 (25.4)	5800 (399)

Nuts

Female				
FO Size (in.)	Basic Ordering Number	Dimensions, in. (mm)		
		L	G	
1/8-1/4	-N-FO4	0.66 (16.8)	11/16 (17.5)	
3/8-1/2	-N-FO8	0.69 (17.5)	1 (25.4)	
3/4	-N-FO12	0.81 (20.6)	1 1/2 (38.1)	
1	-N-FO16	0.81 (20.6)	1 3/4 (44.5)	

Blind				
FO Size (in.)	Basic Ordering Number	Dimensions, in. (mm)		
		L	G	
1/8-1/4	-N-FO4-B	0.44 (11.2)	11/16 (17.5)	
3/8-1/2	-N-FO8-B	0.56 (14.2)	1 (25.4)	
3/4	-N-FO12-B	0.75 (19.1)	1 1/2 (38.1)	
1	-N-FO16-B	0.81 (20.6)	1 3/4 (44.5)	

Bodies

FO Body to Male NPT							
FO Size (in.)	P-NPT Size	Basic Ordering Number	Dimensions, in. (mm)				Working pressure psig (bar)
			L	F	B	E	
1/4	1/8	-CM-FO4-NS2	1.16 (29.5)	5/8 (15.9)	0.38 (9.7)	0.18 (4.6)	10000 (689)
1/4	1/4	-CM-FO4-NS4	1.34 (34.0)	5/8 (15.9)	0.56 (14.2)	0.18 (4.6)	13400 (923)
1/2	3/8	-CM-FO8-NS6	1.46 (37.1)	15/16 (23.8)	0.56 (14.2)	0.38 (9.7)	7800 (537)
1/2	1/2	-CM-FO8-NS8	1.65 (41.9)	15/16 (23.8)	0.75 (19.1)	0.40 (10.2)	10000 (689)
3/4	3/4	-CM-FO12-NS12	1.75 (44.5)	1 5/16 (33.3)	0.75 (19.1)	0.62 (15.7)	7300 (502)
1	1	-CM-FO16-NS16	1.97 (50.0)	1 5/8 (41.3)	0.94 (23.9)	0.87 (22.1)	5300 (365)

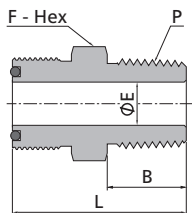

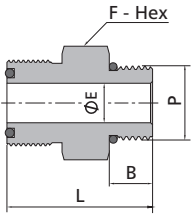

FO Body to SAE/MS Thread							
FO Size (in.)	P-SAE/MS Thread Size	Basic Ordering Number	Dimensions, in. (mm)				Working pressure psig (bar)
			L	F	B	E	
1/4	7/16-20	-CM-FO4-ST7	1.24 (31.5)	11/16 (17.5)	0.36 (9.1)	0.18 (4.6)	4500 (310)
1/4	9/16-18	-CM-FO4-ST9	1.17 (29.7)	11/16 (17.5)	0.39 (9.9)	0.18 (4.6)	4500 (310)
1/2	7/16-20	-CM-FO8-ST7	1.36 (34.5)	15/16 (23.8)	0.36 (9.1)	0.18 (4.6)	4500 (310)
1/2	9/16-18	-CM-FO8-ST9	1.39 (35.3)	15/16 (23.8)	0.39 (9.9)	0.30 (7.6)	4500 (310)
1/2	3/4-16	-CM-FO8-ST12	1.47 (37.3)	1 (25.4)	0.44 (11.2)	0.40 (10.2)	4500 (310)
3/4	1 1/16-12	-CM-FO12-ST17	1.73 (43.9)	1 3/8 (34.9)	0.59 (15.0)	0.62 (15.7)	3600 (248)
1	1 5/16-12	-CM-FO16-ST21	1.79 (45.5)	1 5/8 (41.3)	0.59 (15.0)	0.85 (21.6)	2900 (199)

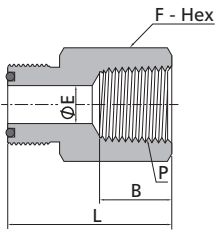

FO Body to Female NPT							
FO Size (in.)	P-NPT Size	Basic Ordering Number	Dimensions, in. (mm)				Working Pressure psig (bar)
			L	F	B	E	
1/4	1/8	-CF-FO4-NS2	1.25 (31.8)	5/8 (15.9)	0.41 (10.4)	0.18 (4.6)	8400 (578)
1/4	1/4	-CF-FO4-NS4	1.39 (35.3)	3/4 (19.1)	0.59 (15.0)	0.18 (4.6)	6600 (454)
1/2	3/8	-CF-FO8-NS6	1.57 (39.9)	15/16 (23.8)	0.59 (15.0)	0.40 (10.2)	6600 (454)
1/2	1/2	-CF-FO8-NS8	1.77 (45.0)	1 1/16 (27.0)	0.78 (19.8)	0.40 (10.2)	4900 (337)
3/4	3/4	-CF-FO12-NS12	1.93 (49.0)	1 5/16 (33.3)	0.81 (20.6)	0.62 (15.7)	4600 (316)
1	1	-CF-FO16-NS16	2.02 (51.3)	1 5/8 (41.3)	1.00 (25.4)	0.87 (22.1)	4400 (303)

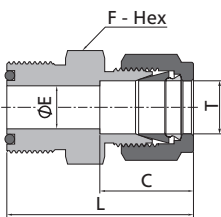

FO Body to Tube Fitting							
FO Size (in.)	T-tube O.D. (in.)	Basic Ordering Number	Dimensions, in. (mm)				Working Pressure psig (bar)
			L	F	C	E	
1/4	1/8	-U-FO4-FL2	1.38 (35.1)	5/8 (15.9)	0.51 (13.0)	0.09 (2.3)	10900 (751)
1/4	1/4	-U-FO4-FL4	1.47 (37.3)	5/8 (15.9)	0.60 (15.2)	0.18 (4.6)	10200 (702)
1/2	3/8	-U-FO8-FL6	1.65 (41.9)	15/16 (23.8)	0.66 (16.8)	0.28 (7.1)	6500 (447)
1/2	1/2	-U-FO8-FL8	1.78 (45.2)	15/16 (23.8)	0.90 (22.9)	0.40 (10.2)	6700 (461)
3/4	3/4	-U-FO12-FL12	1.86 (47.2)	1 5/16 (33.3)	0.96 (24.4)	0.62 (15.7)	5800 (399)
1	1	-U-FO16-FL16	2.06 (52.3)	1 5/8 (41.3)	1.23 (31.2)	0.87 (22.1)	4700 (323)

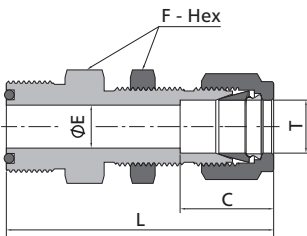

FO Body to Bulkhead Tube Fitting										
FO Size (in.)	T-tube O.D. (in.)	Basic Ordering Number	Dimensions, in. (mm)				Panel Hole Drill Size in. (mm)	Max. Panel Thickness in. (mm)	Working Pressure psig (bar)	
			L	F	C	E				
1/4	1/4	-UB-FO4-FL4	2.10 (53.4)	5/8 (15.9)	0.60 (15.2)	0.18 (4.6)	0.45 (11.5)	0.40 (10.2)	10200 (702)	
1/2	3/8	-UB-FO8-FL6	2.34 (59.4)	15/16 (23.8)	0.66 (16.8)	0.28 (7.1)	0.58 (14.7)	0.44 (11.2)	6500 (447)	
1/2	1/2	-UB-FO8-FL8	2.55 (64.8)	15/16 (23.8)	0.90 (22.9)	0.40 (10.2)	0.76 (19.4)	0.50 (12.7)	6700 (461)	
3/4	3/4	-UB-FO12-FL12	2.86 (72.6)	1 5/16 (33.3)	0.96 (24.4)	0.62 (15.7)	1.02 (25.8)	0.66 (16.8)	5800 (399)	
1	1	-UB-FO16-FL16	3.29 (83.6)	1 5/8 (41.3)	1.23 (31.2)	0.87 (22.1)	1.33 (33.7)	0.75 (19.1)	4700 (323)	

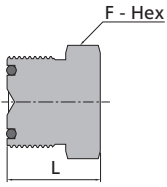

Blind Body			
FO Size (in.)	Basic Ordering Number	Dimensions, in. (mm)	
		L	F
1/4	-BY-FO4	0.77 (19.6)	5/8 (15.9)
1/2	-BY-FO8	0.89 (22.6)	15/16 (23.8)
3/4	-BY-FO12	0.99 (25.1)	1 5/16 (33.3)
1	-BY-FO16	1.02 (25.9)	1 5/8 (41.3)

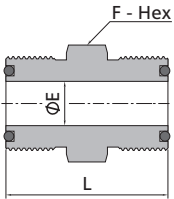

Union Body						
FO Size (in.)	FO Size (in.)	Basic Ordering Number	Dimensions, in. (mm)			Working Pressure psig (bar)
			L	F	E	
1/4	1/4	-U-FO4	1.25 (31.8)	5/8 (15.9)	0.18 (4.6)	14300 (985)
1/2	1/4	-U-FO8-FO4	1.43 (36.3)	15/16 (23.8)	0.18 (4.6)	11100 (764)
1/2	1/2	-U-FO8	1.50 (38.1)	15/16 (23.8)	0.40 (10.2)	11100 (764)

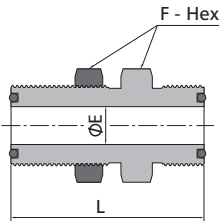

Bulkhead Union Body							
FO Size (in.)	Basic Ordering Number	Dimensions, in. (mm)			Panel Hole Drill Size in. (mm)	Max. Panel Thickness in. (mm)	Working Pressure psig (bar)
		L	F	E			
1/4	-BU-FO4	1.88 (47.8)	3/4 (19.1)	0.18 (4.60)	0.58 (14.7)	0.36 (9.10)	14300 (985)
1/2	-BU-FO8	2.09 (53.1)	1 1/16 (27.0)	0.40 (10.2)	0.89 (22.6)	0.40 (10.2)	11100 (764)

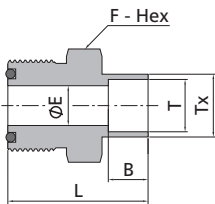

FO Body to Tube Socket Weld								
FO Size (in.)	T-Tube O.D. (in.)	Basic Ordering Number	Dimensions, in. (mm)					Working Pressure psig (bar)
			L	F	E	B	Tx	
1/8	1/8	-CW-FO4-TS2	0.88 (22.4)	5/8 (15.9)	0.09 (2.3)	0.10 (2.5)	0.29 (7.4)	12600 (868)
1/4	1/4	-CW-FO4-TS4	1.09 (27.7)	5/8 (15.9)	0.18 (4.6)	0.28 (7.1)	0.38 (9.7)	6800 (468)
3/8	3/8	-CW-FO8-TS6	1.28 (32.5)	15/16 (23.8)	0.28 (7.1)	0.31 (7.9)	0.60 (15.2)	8100 (558)
1/2	1/2	-CW-FO8-TS8	1.34 (34.0)	15/16 (23.8)	0.40 (10.2)	0.38 (9.7)	0.60 (15.2)	3000 (206)
3/4	3/4	-CW-FO12-TS12	1.50 (38.1)	1 5/16 (33.3)	0.62 (15.7)	0.44 (11.2)	0.92 (23.4)	3700 (254)
1	1	-CW-FO16-TS16	1.72 (43.7)	1 5/8 (41.3)	0.87 (22.1)	0.62 (15.7)	1.19 (30.2)	3000 (206)

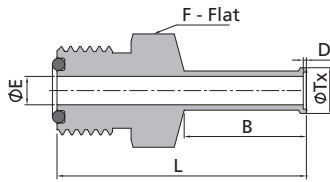

FO Body to Automatic Tube Weld											
FO Size (in.)	T-tube O.D. (in.)	Wall (in.)	Basic Ordering Number	Dimensions, in. (mm)						Working Pressure psig (bar)	
				L	B	D	E	Tx	F		
1/4	1/4	0.035	-CW-FO4-TB4A	1.59 (40.4)	0.78 (19.8)	0.02 (0.5)	0.18 (4.6)	0.29 (7.4)	5/8 (15.9)	5100 (351)	
1/2	3/8	0.035	-CW-FO8-TB6A	1.74 (44.2)	0.79 (20.0)	0.03 (0.8)	0.31 (7.9)	0.41 (10.4)	15/16 (23.8)	3300 (227)	
1/2	1/2	0.049	-CW-FO8-TB8A	1.75 (44.4)	0.80 (20.3)	0.04 (1.0)	0.40 (10.2)	0.55 (14.0)	15/16 (23.8)	3500 (241)	
3/4	3/4	0.049	-CW-FO12-TB12A	1.78 (45.2)	0.80 (20.3)	0.04 (1.0)	0.65 (16.5)	0.80 (20.3)	1 5/16 (23.8)	2200 (151)	
1	1	0.065	-CW-FO16-TB16A	2.03 (51.6)	1.00 (25.4)	0.04 (1.0)	0.87 (22.1)	1.06 (26.9)	1 5/8 (47.6)	2200 (151)	

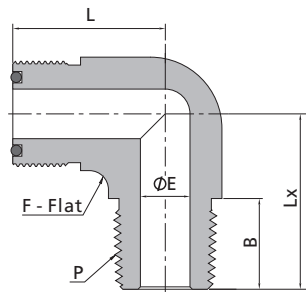

FO Body to Male NPT Elbow									
FO Size (in.)	P-NPT Size	Basic Ordering Number	Dimensions, in. (mm)					Working Pressure psig (bar)	
			L	F	B	E	Lx		
1/4	1/8	-LM-FO4-NS2	0.96 (24.4)	9/16 (14.3)	0.38 (9.7)	0.18 (4.6)	0.87 (22.1)	10000 (689)	
1/4	1/4	-LM-FO4-NS4	0.96 (24.4)	9/16 (14.3)	0.56 (14.2)	0.18 (4.6)	1.05 (26.7)	8000 (551)	
1/2	3/8	-LM-FO8-NS6	1.26 (32.0)	13/16 (20.6)	0.56 (14.2)	0.38 (9.7)	1.26 (32.0)	7800 (537)	
1/2	1/2	-LM-FO8-NS8	1.26 (32.0)	13/16 (20.6)	0.75 (19.1)	0.40 (10.2)	1.45 (36.8)	7700 (530)	
3/4	3/4	-LM-FO12-NS12	1.48 (37.6)	1 1/4 (31.8)	0.75 (19.1)	0.62 (15.7)	1.67 (42.4)	7300 (502)	
1	1	-LM-FO16-NS16	1.56 (39.6)	1 11/16 (42.9)	0.94 (23.9)	0.87 (22.0)	1.94 (49.3)	5300 (365)	

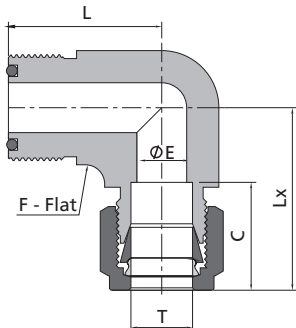

FO Body to Tube Fitting Elbow									
FO Size (in.)	T-Tube O.D. (in.)	Basic Ordering Number	Dimensions, in. (mm)					Working Pressure psig (bar)	
			L	F	C	E	Lx		
1/4	1/4	-LU-FO4-FL4	0.96 (24.4)	9/16 (14.3)	0.60 (15.2)	0.18 (4.6)	1.19 (30.2)	10200 (702)	
1/2	3/8	-LU-FO8-FL6	1.26 (32.0)	13/16 (20.6)	0.66 (16.8)	0.28 (7.1)	1.39 (35.3)	6500 (447)	
1/2	1/2	-LU-FO8-FL8	1.26 (32.0)	13/16 (20.6)	0.90 (22.9)	0.40 (10.2)	1.50 (38.1)	6700 (461)	
3/4	3/4	-LU-FO12-FL12	1.48 (37.6)	1 1/4 (31.8)	0.96 (24.4)	0.62 (15.7)	1.80 (45.7)	5800 (399)	
1	1	-LU-FO16-FL16	1.56 (39.6)	1 11/16 (42.9)	1.23 (31.2)	0.87 (22.1)	2.04 (51.8)	4700 (323)	

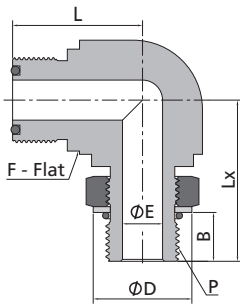

FO Body to Male SAE/MS Thread Adjustable Elbow									
FO Size (in.)	P-SAE/MS Thread Size	Basic Ordering Number	Dimensions, in. (mm)						Working Pressure psig (bar)
			L	F	B	E	D	Lx	
1/4	7/16-20	-LP-FO4-ST7	0.96 (24.4)	1/2 (12.7)	0.39 (9.9)	0.18 (4.6)	0.65 (16.5)	1.19 (30.2)	4500 (310)
1/2	9/16-18	-LP-FO8-ST9	1.33 (33.8)	13/16 (20.6)	0.44 (11.2)	0.30 (7.6)	0.79 (20.1)	1.54 (39.1)	3600 (248)
1/2	3/4-16	-LP-FO8-ST12	1.33 (33.8)	13/16 (20.6)	0.50 (12.7)	0.40 (10.2)	1.01 (25.7)	1.65 (41.9)	3600 (248)
3/4	1 1/16-12	-LP-FO12-ST17	1.53 (38.9)	1 1/4 (31.8)	0.66 (16.8)	0.62 (15.7)	1.44 (36.6)	2.13 (54.1)	2900 (199)
1	1 5/16-12	-LP-FO16-ST21	1.72 (43.7)	1 11/16 (42.9)	0.66 (16.8)	0.87 (22.1)	1.73 (43.9)	2.31 (58.7)	2300 (158)

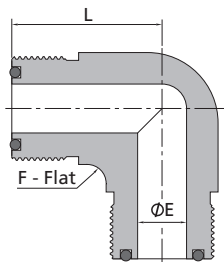

FO Body Union Elbow					
FO Size (in.)	Basic Ordering Number	Dimensions, in. (mm)			Working Pressure psig (bar)
		L	F	E	
1/4	-LU-FO4	0.96 (24.4)	9/16 (14.3)	0.18 (4.6)	14300 (985)
1/2	-LU-FO8	1.26 (32.0)	13/16 (20.6)	0.40 (10.2)	11100 (764)
3/4	-LU-FO12	1.48 (37.6)	1 1/4 (31.8)	0.62 (15.7)	10900 (751)
1	-LU-FO16	1.56 (39.6)	1 11/16 (42.9)	0.87 (22.1)	8800 (606)

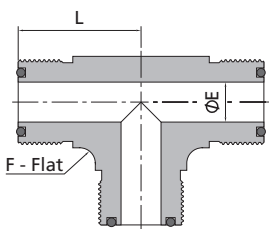

FO Body Union Tee					
FO Size (in.)	Basic Ordering Number	Dimensions, in. (mm)			Working Pressure psig (bar)
		L	F	E	
1/4	-TTT-FO4	0.96 (24.4)	9/16 (14.3)	0.18 (4.6)	14300 (985)
1/2	-TTT-FO8	1.26 (32.0)	13/16 (20.6)	0.40 (10.2)	11100 (764)
3/4	-TTT-FO12	1.48 (37.6)	1 1/4 (31.8)	0.62 (15.7)	10900 (751)
1	-TTT-FO16	1.56 (39.6)	1 11/16 (42.9)	0.87 (22.1)	8800 (606)

O-rings

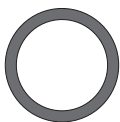

FO Size (in.)	Basic Ordering Number
1/8-1/4	-010
3/8-1/2	-111
3/4	-116
1	-215

Add the O-ring material designator in page F-42 as a prefix to the basic ordering number to get the complete ordering number.

Example: V17-010

Diaphragm Valves

DQ, DP, DH, DM, DS, DR, DV, DL and DF Series



Diaphragm Valves

DQ Series Low Pressure Manual Diaphragm Valves

Features

- Low internal volume, fully swept flow path
- Contained seat to provide excellent resistance to swelling and contamination
- Elgiloy diaphragm to provide high strength and corrosion resistance to ensure long cycle life
- Different handle types available
- Suitable for ultra high purity applications

Technical Data

Port Size	1/4" to 3/8" or 6 mm to 8 mm	
Flow Coefficient (Cv)	0.27	
Orifice Size	0.16 in. (4.1 mm)	
Max. Working Pressure	250 psig (17.2 bar)	
Temperature	PCTFE: -10~150°F (-23~65°C) PFA: -10~302°F (-23~150°C)	
Leak Rate (Helium)	Internal	≤ 1x10 ⁻⁹ mbar l/s
	External	≤ 1x10 ⁻⁹ mbar l/s

Flow Data

Air @ 70°F (21°C)
Water @ 60°F (16°C)

Pressure Drop to Atmosphere psi (bar)	Air (l/min)	Water (l/min)
10 (0.68)	86	3.2
50 (3.4)	230	7.2
100 (6.8)	410	10.2

Product Technology Grade

Product Grade Technology	General Purpose	Special Cleaning and Packaging (F2)	Ultra High Purity (F3)
Material/Specification	316L SS/ASTM A479		316L VAR/SEMI F20 316L VIM-VAR /SEMI F20
Wetted Surface Roughness	Ra 10 μin. (0.25 μm) ^①		Ra 5 μin. (0.13 μm)
Polishing Process	Machine finished ^①		Electropolished
Process Specification	FC-01 Standard Cleaning and Packaging	FC-02 Special Cleaning and Packaging	FC-03 Ultra High Purity Process Specification
Cleaning	Thrice degreasing ultrasonic cleaning	Special cleaning with non-ozone-depleting chemicals	Ultra high purity cleaning in continuously monitored ultrasonic cleaning system with deionized water
Assembly Environment	At atmosphere	In specially cleaned areas	In ISO Class 5/Federal Class 100 cleanroom
Packaging	Individually bagged	Double bagged	Double bagged and vacuum sealed in cleanroom

① For FR connections and tube butt connections, the standard polishing process is electropolishing and the internal surface roughness is finished to an average of Ra 5 μin. (0.13 μm).

Major Materials of Construction

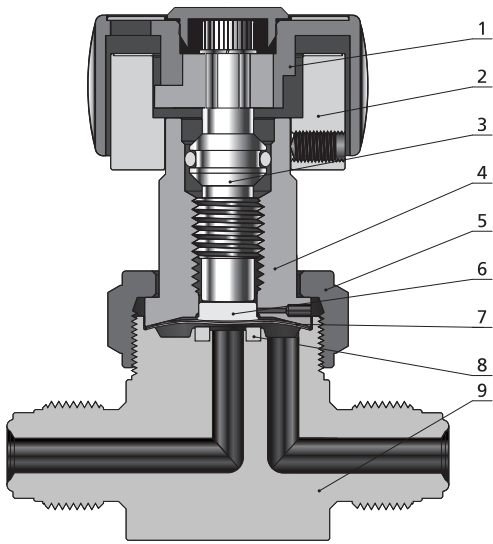

Round Handle Model

Item	Component		Material/Specification
1	Handle	Round	ABS
		Integral Lockout	Aluminum
2	Actuator		Aluminum
3	Stem		316 SS/ASTM A479
4	Bonnet		S17400/ASTM A564
5	Bonnet Nut		316 SS/ASTM A479
6	Button		316 SS/ASTM A479
7	Diaphragm (2)		Elgiloy/AMS 5876
8	Seat		PCTFE/ASTM D1430 or PFA/ASTM D3307
9	Body		316 SS/ASTM A479 or 316L SS/ASTM A479 or 316L VIM-VAR/SEMI F20

Manual Actuators

Round Handle

- ⦿ Quick, quarter-turn actuation
- ⦿ Handle with window to visually indicate open and closed states



OPEN

CLOSED

Integral Lockout Handle

- ⦿ Quick, quarter-turn actuation
- ⦿ Lockable in the closed position for safety



Dimensions and Ordering Information

Straight Type

Dimensions

Dimensions, in inches (millimeters), are for reference only.

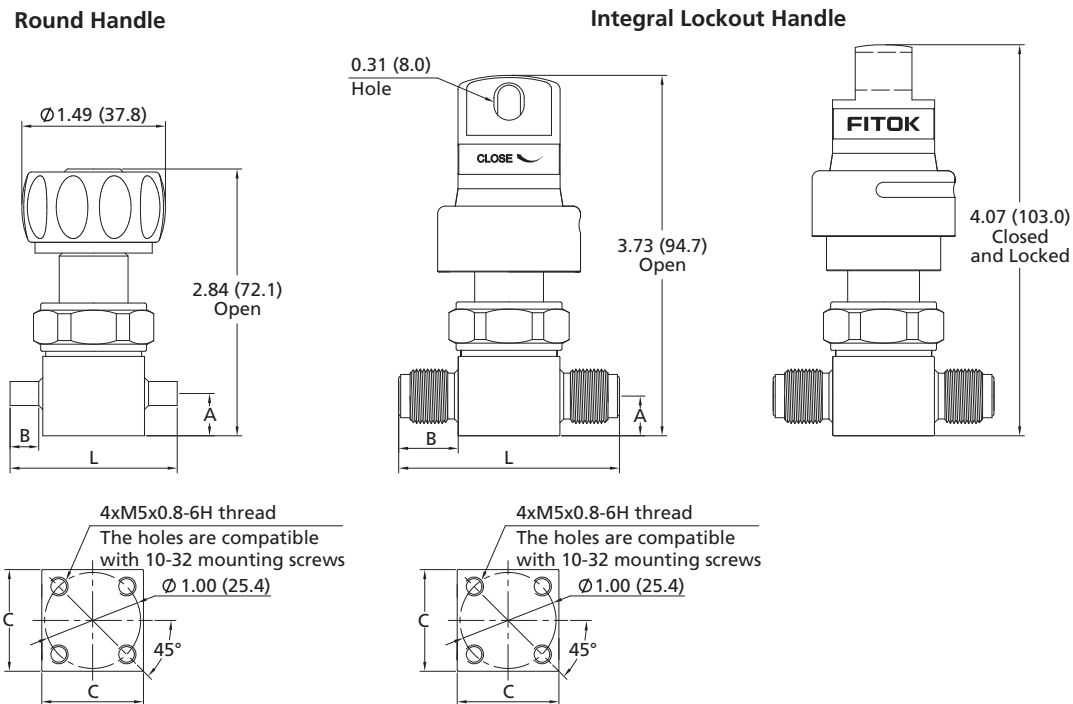

Basic Ordering Number	Connection Type and Size	Dimensions in. (mm)			
		A	B	C	L
DQ□□-TB4-	1/4" Tube Butt Weld	0.44 (11.2)	0.30 (7.6)	1.06 (26.9)	1.74 (44.2)
DQ□□-TB6-	3/8" Tube Butt Weld	0.44 (11.2)	0.26 (6.6)	1.06 (26.9)	1.74 (44.2)
DQ□□-FFR4-	1/4" Female FR	0.44 (11.2)	0.86 (21.8)	1.06 (26.9)	2.78 (70.6)
DQ□□-RFR4-	1/4" Rotatable Male FR	0.44 (11.2)	0.86 (21.8)	1.06 (26.9)	2.78 (70.6)
DQ□□-FR4-	1/4" Integral Male FR	0.44 (11.2)	0.62 (15.7)	1.06 (26.9)	2.30 (58.4)

Ordering Number Description

DQ6L - TB4 - FR4 - RAF2

Body Material		Inlet Type		Inlet Size		Outlet Type	Outlet Size	Handle Type		Seat	Technology Grade	
6L	316L SS	TB	Fractional Tube Butt Weld	4	1/4"	Same as Inlet	Specified in the same way as Inlet type and size	R	Round	PCTFE	General Purpose	
6LV	316L VAR	MTB	Metric Tube Butt Weld	6	6 mm or 3/8"			U	Integral Lockout	A	PFA	F2
6LW	316L VIM-VAR	FR	Integral Male FR Fitting	8	8 mm						F3	Ultra High Purity
		FFR	Female FR Fitting									
		RFR	Rotatable Male FR Fitting									
		FL	Fractional Tube Fitting									
		ML	Metric Tube Fitting									

Branch Type

Dimensions

Dimensions, in inches (millimeters), are for reference only.

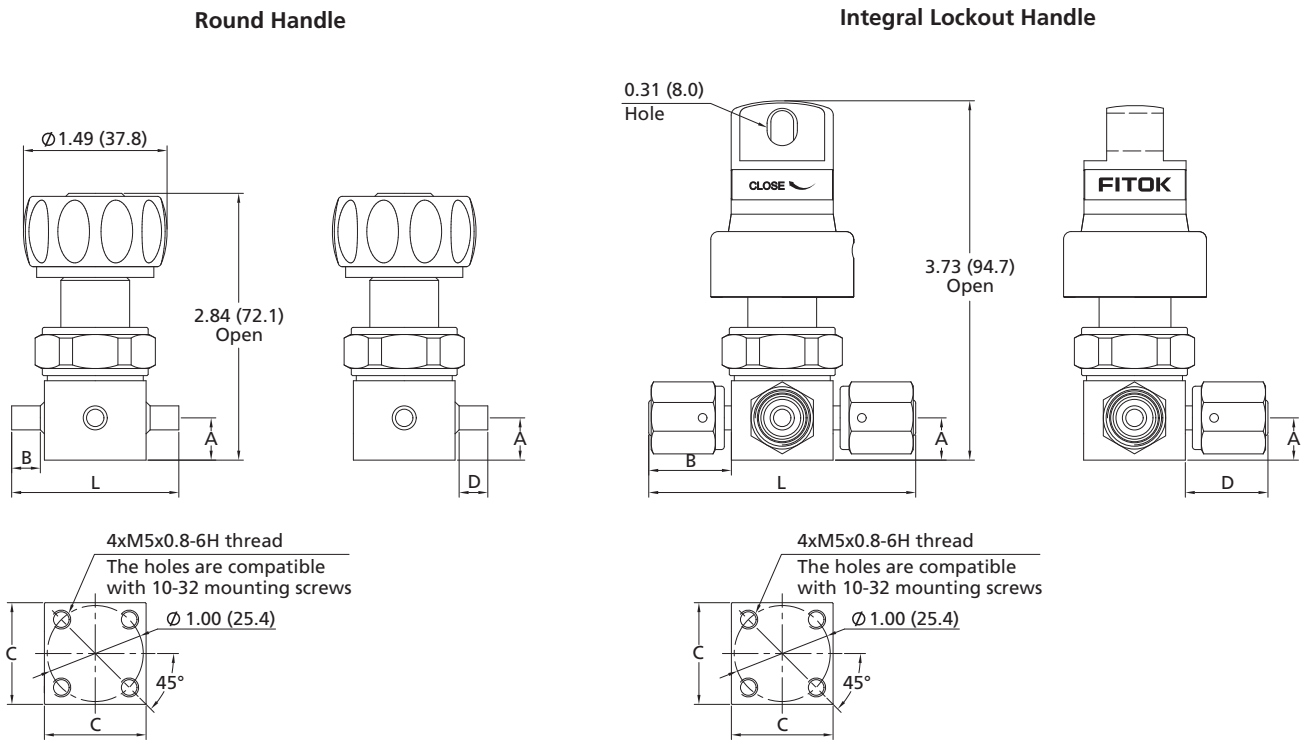

Basic Ordering Number	Connection Type and Size	Dimensions in. (mm)				
		A	B	C	D	L
DQ□□-TB4-	1/4" Tube Butt Weld	0.44 (11.2)	0.30 (7.6)	1.06 (26.9)	0.30 (7.6)	1.74 (44.2)
DQ□□-TB6-	3/8" Tube Butt Weld	0.44 (11.2)	0.26 (6.6)	1.06 (26.9)	0.26 (6.6)	1.74 (44.2)
DQ□□-FFR4-	1/4" Female FR	0.44 (11.2)	0.86 (21.8)	1.06 (26.9)	0.86 (21.8)	2.78 (70.6)
DQ□□-RFR4-	1/4" Rotatable Male FR	0.44 (11.2)	0.86 (21.8)	1.06 (26.9)	0.86 (21.8)	2.78 (70.6)
DQ□□-FR4-	1/4" Integral Male FR	0.44 (11.2)	0.62 (15.7)	1.06 (26.9)	0.62 (15.7)	2.30 (58.4)

Flow Paths

☉ Flow paths as viewed from the top

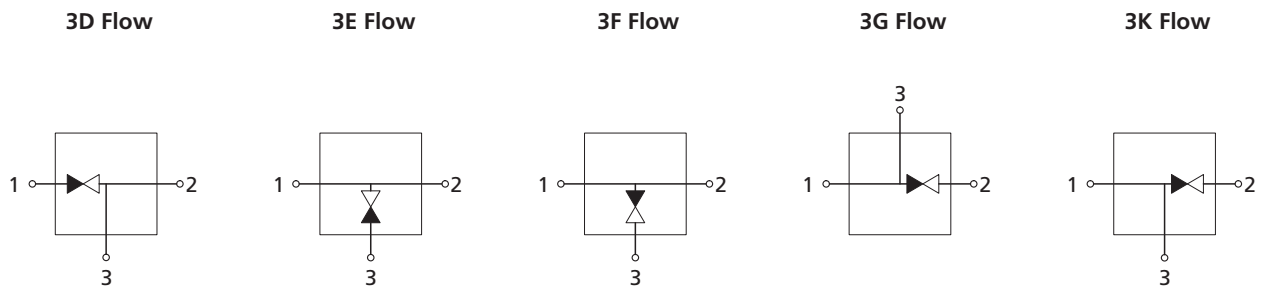

Ordering Number Description

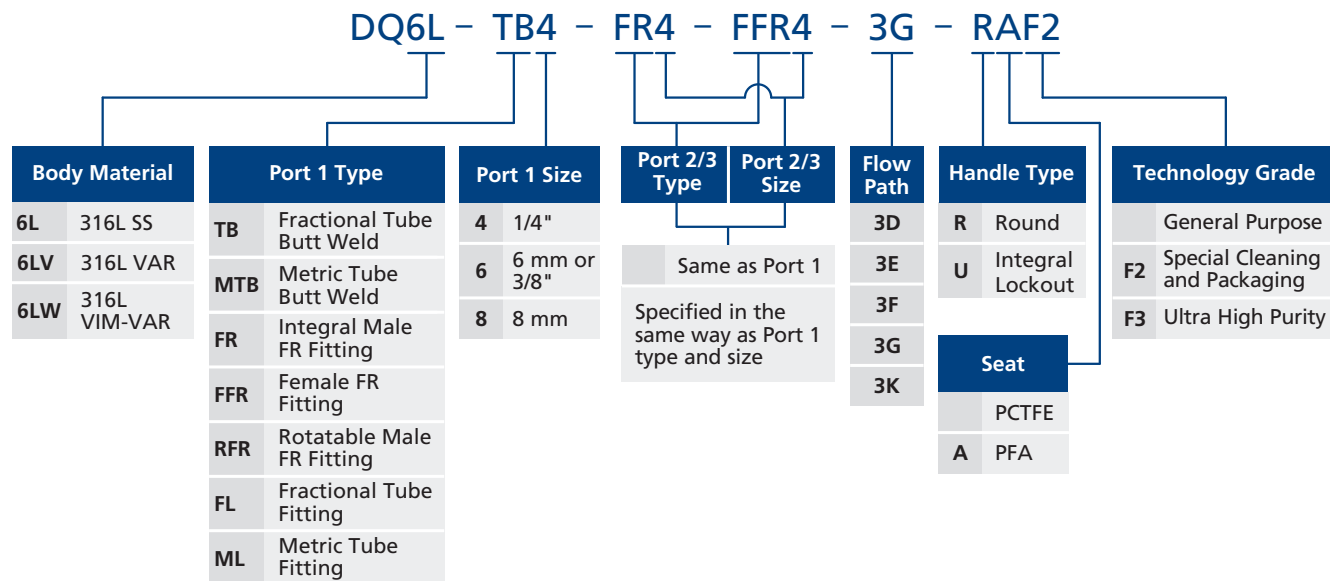

2-Valve 3-Way Block Type

Dimensions

Dimensions, in inches (millimeters), are for reference only.

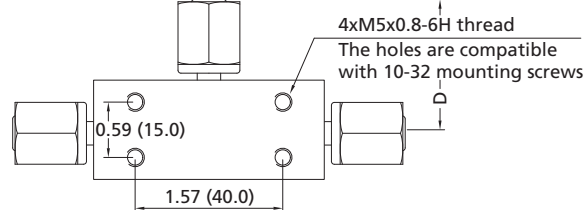
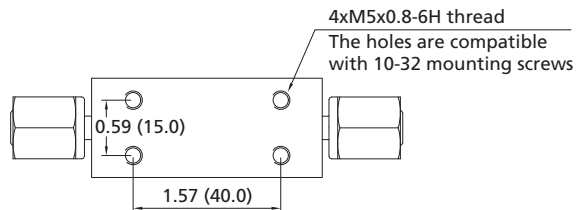
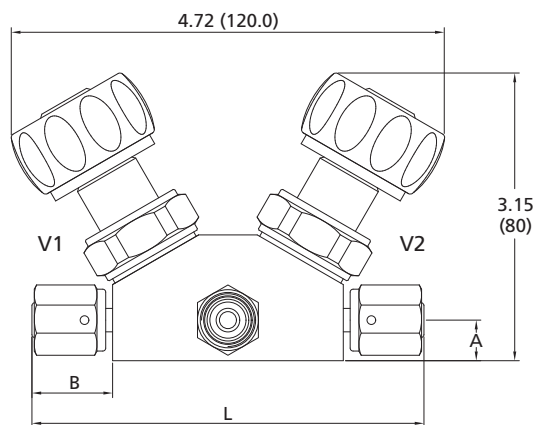
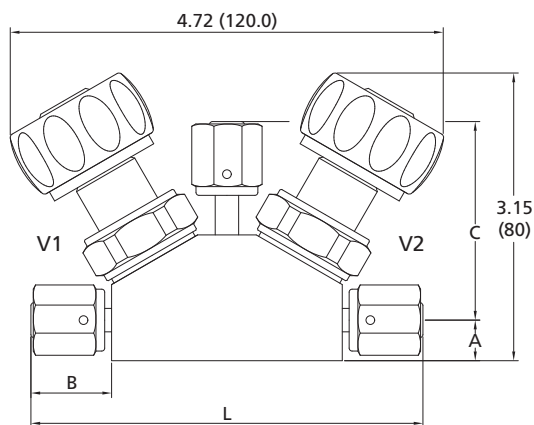

Basic Ordering Number	Connection Type and Size	Dimensions in. (mm)				
		A	B	C	D	L
DQ23□□-FFR4-	1/4" Female FR	0.44 (11.2)	0.86 (21.8)	2.12 (53.8)	—	4.24 (107.6)
DQ23□□-FFR4-	1/4" Female FR	0.44 (11.2)	0.86 (21.8)	—	1.37 (34.8)	4.24 (107.6)
DQ23□□-RFR4-	1/4" Rotatable Male FR	0.44 (11.2)	0.86 (21.8)	2.12 (53.8)	—	4.24 (107.6)
DQ23□□-RFR4-	1/4" Rotatable Male FR	0.44 (11.2)	0.86 (21.8)	—	1.37 (34.8)	4.24 (107.6)

Flow Paths

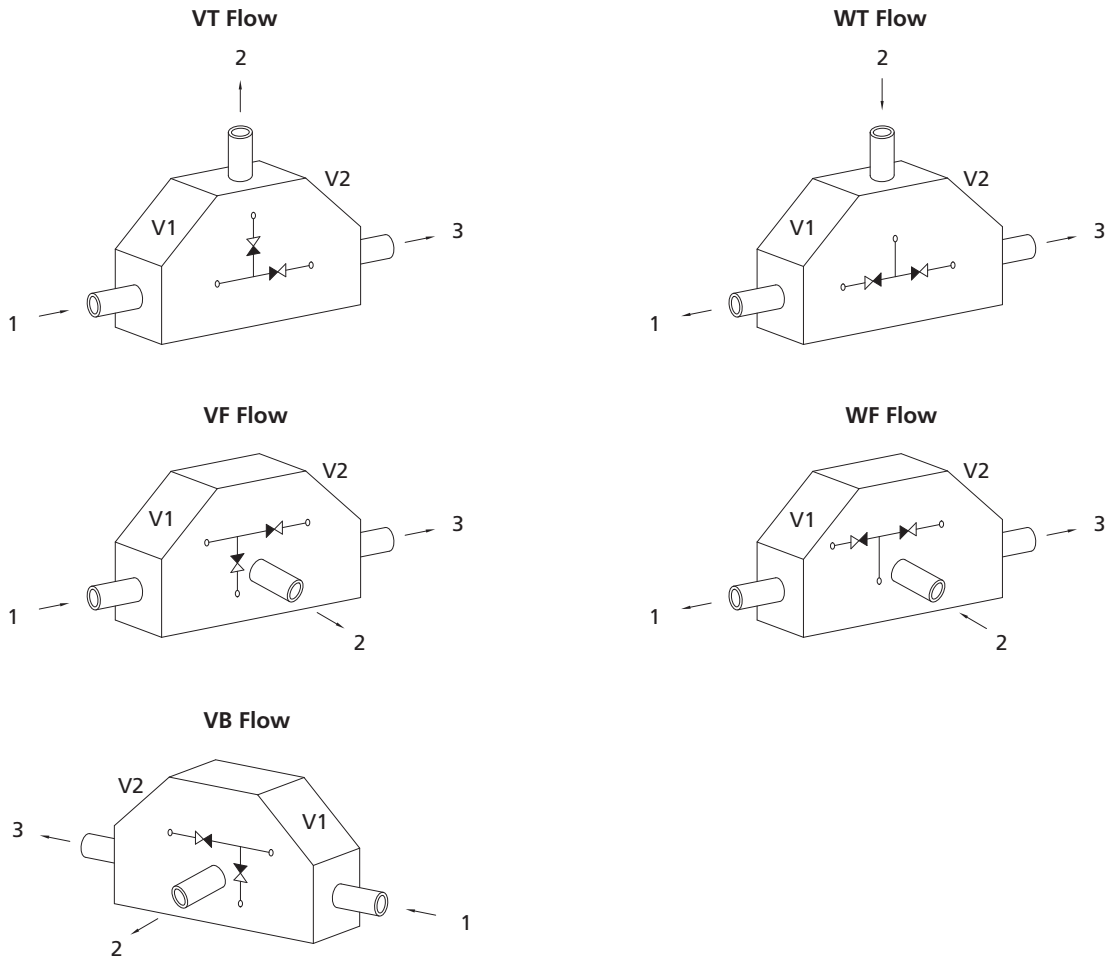

Ordering Number Description

DQ236L - FFR4 - RFR4 - FFR4 - VF - RAF2

Type	Body Material	Port 1 Type	Port 1 Size	Port 2/3 Type	Port 2/3 Size	Flow Path	Seat	Technology Grade
23 2 Valves and 3 Ports	6L 316L SS	FFR Female FR Fitting	4 1/4"	Same as Port 1	Specified in the same way as Port 1 type and size	VT	PCTFE	General Purpose
	6LV 316L VAR	RFR Rotatable Male FR Fitting				VF	A PFA	F2 Special Cleaning and Packaging
	6LW 316L VIM-VAR	RFR Rotatable Male FR Fitting				VB	Handle Type	F3 Ultra High Purity
						WT	R Round	
						WF	U Integral Lcokout	

3-Valve 4-Way Block Type

Dimensions

Dimensions, in inches (millimeters), are for reference only.

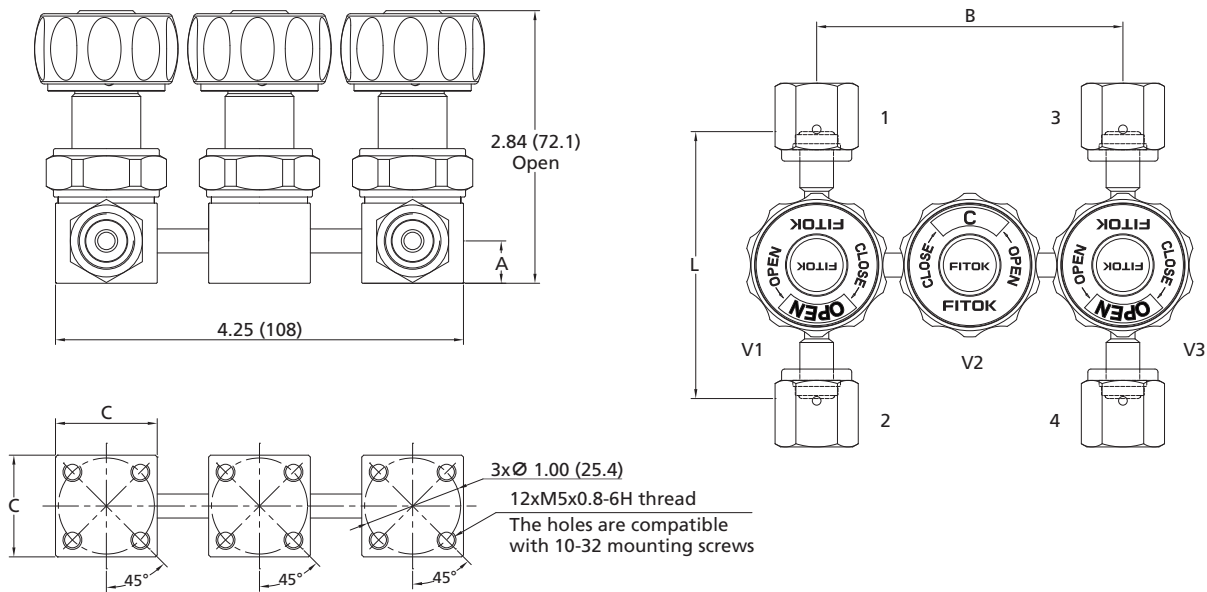

Basic Ordering Number	Connection Type and Size	Dimensions in. (mm)			
		A	B	C	L
DQ34□□-FFR4-	1/4" Female FR	0.44 (11.2)	3.19 (81.0)	1.06 (26.9)	2.78 (70.6)
DQ34□□-RFR4-	1/4" Rotatable Male FR	0.44 (11.2)	3.19 (81.0)	1.06 (26.9)	2.78 (70.6)

Flow Paths

☉ Flow paths as viewed from the top

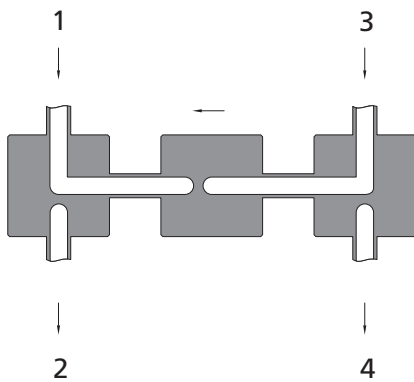

GK Flow

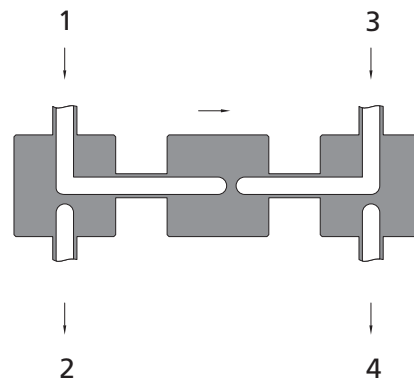

KG Flow

Ordering Number Description

DQ346L - FFR4 - RFR4 - FFR4 - FFR4 - GK - RAF3

Type	Body Material	Port 1 Type	Port 1 Size	Port 2/3/4 Type	Port 2/3/4 Size	Flow Path	Handle Type	Technology Grade
3 Valves and 4 Ports 34	6L 316L SS	FFR Female FR Fitting	4 1/4"	Same as Port 1	Specified in the same way as Port 1 type and size	GK	R Round	General Purpose
	6LV 316L VAR	RFR Rotatable Male FR Fitting				KG	U Integral Lockout	F2 Special Cleaning and Packaging
	6LW 316L VIM-VAR	RFR Rotatable Male FR Fitting				Seat		F3 Ultra High Purity
								PCTFE
								A PFA

Diaphragm Valves

DP Series Low Pressure Pneumatic Diaphragm Valves

Features

- ⦿ Minimum particle generation and dead space
- ⦿ Fully contained seat to provide excellent resistance to swelling and contamination
- ⦿ Elgiloy diaphragm to provide high strength and corrosion resistance
- ⦿ Long cycle life with high speed actuation
- ⦿ Internally threadless and springless
- ⦿ Fully functional under vacuum conditions
- ⦿ Indicator switch available assembled on normally closed valves, transmitting a signal to an electrical device to indicated either the open or closed position of the valves

Technical Data

Port Size	1/4" to 3/8" or 6 mm to 8 mm	
Flow Coefficient (Cv)	0.27	
Orifice Size	0.16 in. (4.1 mm)	
Max. Working Pressure	250 psig (17.2 bar)	
Pneumatic Actuator Operating Pressure	60 to 90 psig (4.2 to 6.2 bar)	
	70 psig (4.8 bar) for actuator with indicator switch	
Temperature	PCTFE: -10~150°F (-23~65°C) PFA: -10~302°F (-23~150°C)	
Leak Rate (Helium)	Internal	≤ 1x10 ⁻⁹ mbar l/s
	External	≤ 1x10 ⁻⁹ mbar l/s

Flow Data

Air @ 70°F (21°C)
Water @ 60°F (16°C)

Pressure Drop to Atmosphere psi (bar)	Air (l/min)	Water (l/min)
10 (0.68)	86	3.2
50 (3.4)	230	7.2
100 (6.8)	410	10.2

Product Technology Grade

Product Grade Technology	General Purpose	Special Cleaning and Packaging (F2)	Ultra High Purity (F3)
Material/Specification	316L SS/ASTM A479		316L VAR/SEMI F20 316L VIM-VAR /SEMI F20
Wetted Surface Roughness	Ra 10 μin. (0.25 μm) ^①		Ra 5 μin. (0.13 μm)
Polishing Process	Machine finished ^①		Electropolished
Process Specification	FC-01 Standard Cleaning and Packaging	FC-02 Special Cleaning and Packaging	FC-03 Ultra High Purity Process Specification
Cleaning	Thrice degreasing ultrasonic cleaning	Special cleaning with non-ozone-depleting chemicals	Ultra high purity cleaning in continuously monitored ultrasonic cleaning system with deionized water
Assembly Environment	At atmosphere	In specially cleaned areas	In ISO Class 5/Federal Class 100 cleanroom
Packaging	Individually bagged	Double bagged	Double bagged and vacuum sealed in cleanroom

① For FR connections and tube butt connections, the standard polishing process is electropolishing and the internal surface roughness is finished to an average of Ra 5 μin. (0.13 μm).

Major Materials of Construction

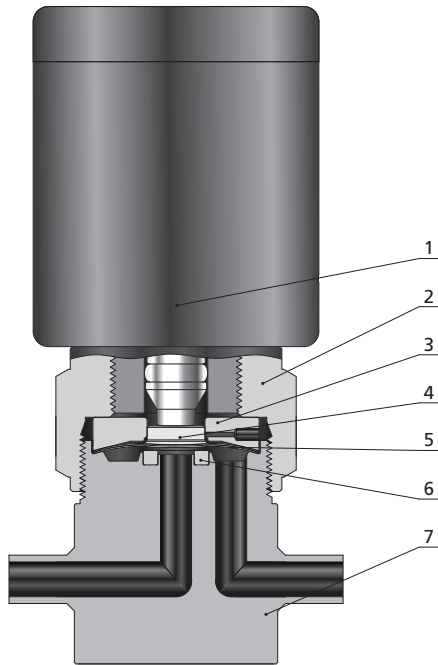

Normally Closed Model

Item	Component	Material/Specification
1	Actuator	Aluminum
2	Bonnet Nut	316 SS/ASTM A479
3	Bonnet	S17400/ASTM A564
4	Button	316 SS/ASTM A479
5	Diaphragm (2)	Elgiloy/AMS 5876
6	Seat	PCTFE/ASTM D1430 or PFA/ASTM D3307
7	Body	316 SS/ASTM A479 or 316L SS/ASTM A479 or 316L VIM-VAR/SEMI F20

Pneumatic Actuators

- ⊙ Normally open, "N.O." marked on the top of the cylinder
- ⊙ Normally closed, "N.C." marked on the top of the cylinder



Normally Open/Closed
Indicator Switch
Rated voltage: 220 V (ac)
Rated current: 1/2 A

Dimensions and Ordering Information

Straight Type

Dimensions

Dimensions, in inches (millimeters), are for reference only.

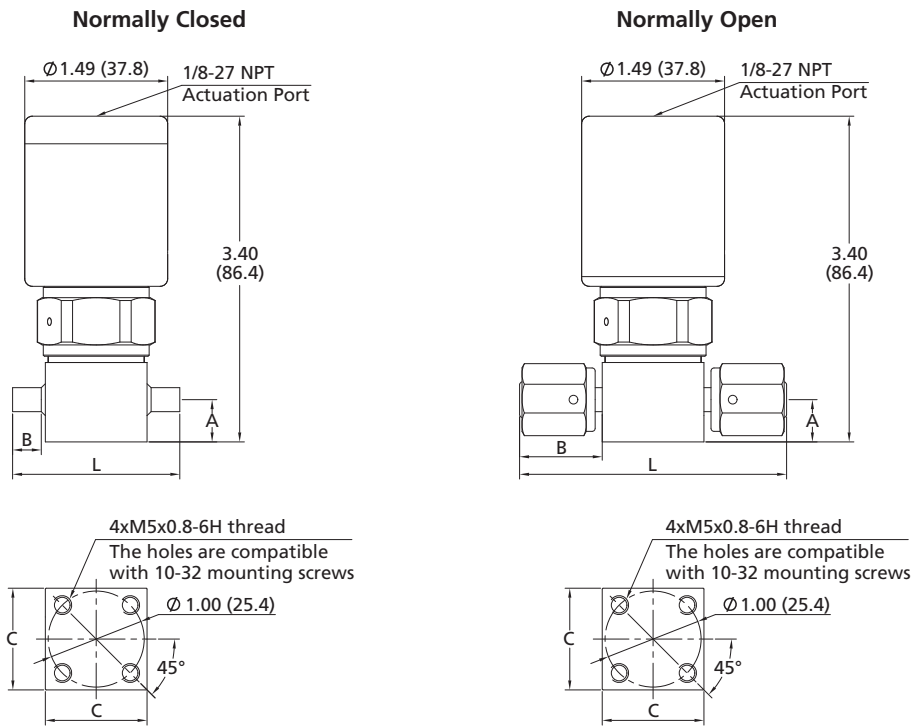

Basic Ordering Number	Connection Type and Size	Dimensions in. (mm)			
		A	B	C	L
DP□□-TB4-	1/4" Tube Butt Weld	0.44 (11.2)	0.30 (7.6)	1.06 (26.9)	1.74 (44.2)
DP□□-TB6-	3/8" Tube Butt Weld	0.44 (11.2)	0.26 (6.6)	1.06 (26.9)	1.74 (44.2)
DP□□-FFR4-	1/4" Female FR	0.44 (11.2)	0.86 (21.8)	1.06 (26.9)	2.78 (70.6)
DP□□-RFR4-	1/4" Rotatable Male FR	0.44 (11.2)	0.86 (21.8)	1.06 (26.9)	2.78 (70.6)
DP□□-FR4-	1/4" Integral Male FR	0.44 (11.2)	0.62 (15.7)	1.06 (26.9)	2.30 (58.4)

Ordering Number Description

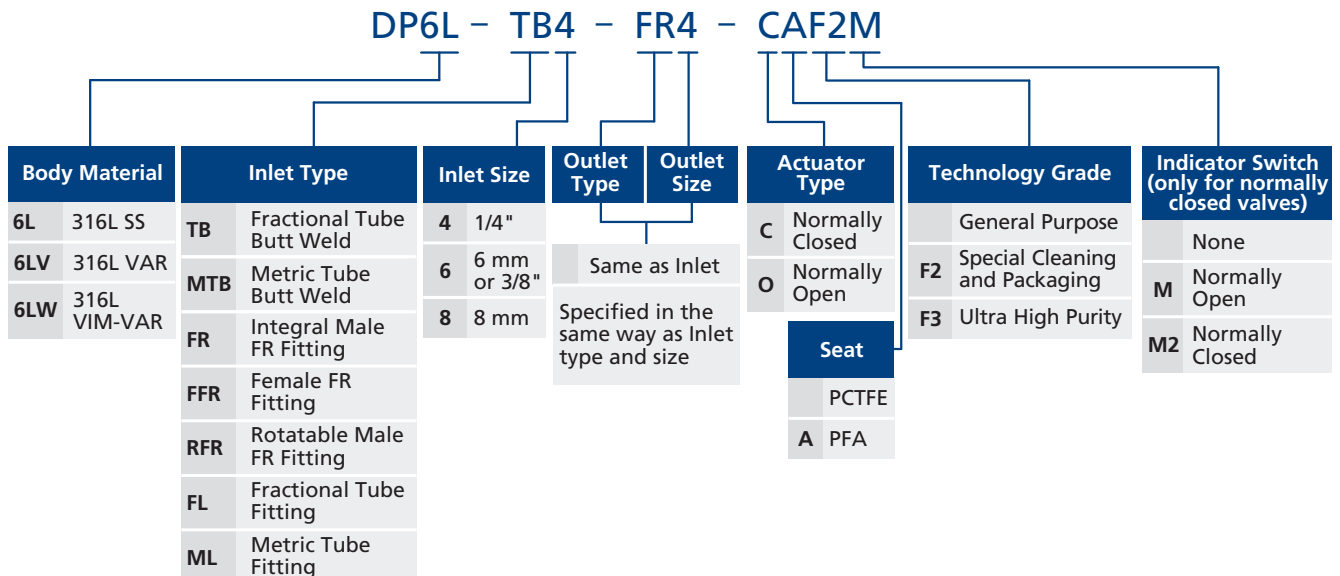

Branch Type

Dimensions

Dimensions, in inches (millimeters), are for reference only.

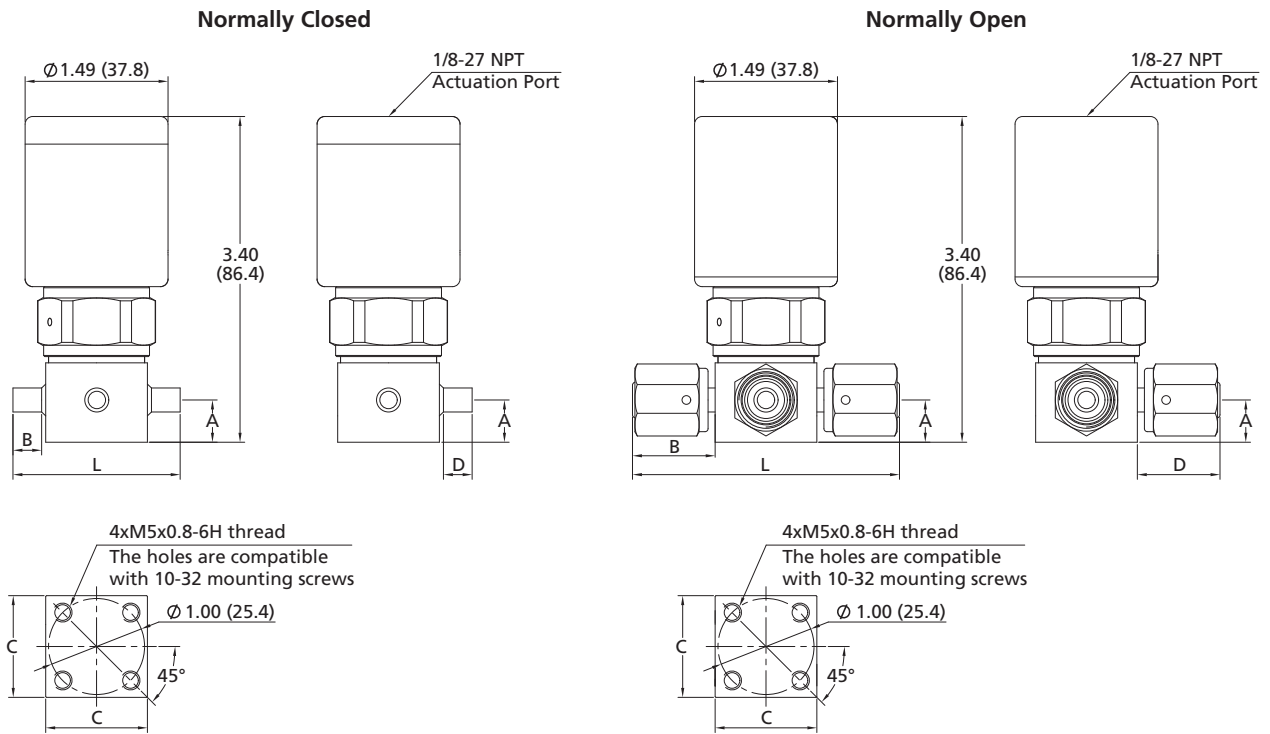

Basic Ordering Number	Connection Type and Size	Dimensions in. (mm)				
		A	B	C	D	L
DP□□-TB4-	1/4" Tube Butt Weld	0.44 (11.2)	0.30 (7.6)	1.06 (26.9)	0.30 (7.6)	1.74 (44.2)
DP□□-TB6-	3/8" Tube Butt Weld	0.44 (11.2)	0.26 (6.6)	1.06 (26.9)	0.26 (6.6)	1.74 (44.2)
DP□□-FFR4-	1/4" Female FR	0.44 (11.2)	0.86 (21.8)	1.06 (26.9)	0.86 (21.8)	2.78 (70.6)
DP□□-RFR4-	1/4" Rotatable Male FR	0.44 (11.2)	0.86 (21.8)	1.06 (26.9)	0.86 (21.8)	2.78 (70.6)
DP□□-FR4-	1/4" Integral Male FR	0.44 (11.2)	0.62 (15.7)	1.06 (26.9)	0.62 (15.7)	2.30 (58.4)

Flow Paths

☉ Flow paths as viewed from the top

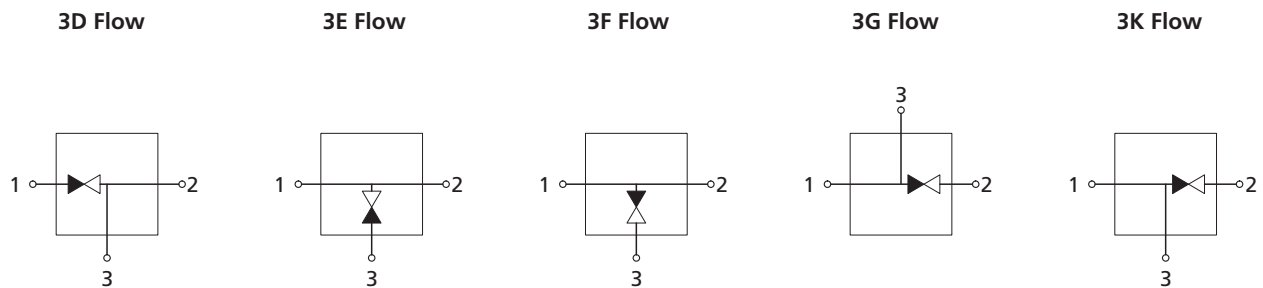

Ordering Number Description

DP6L - TB4 - FR4 - FFR4 - 3G - CAF2M

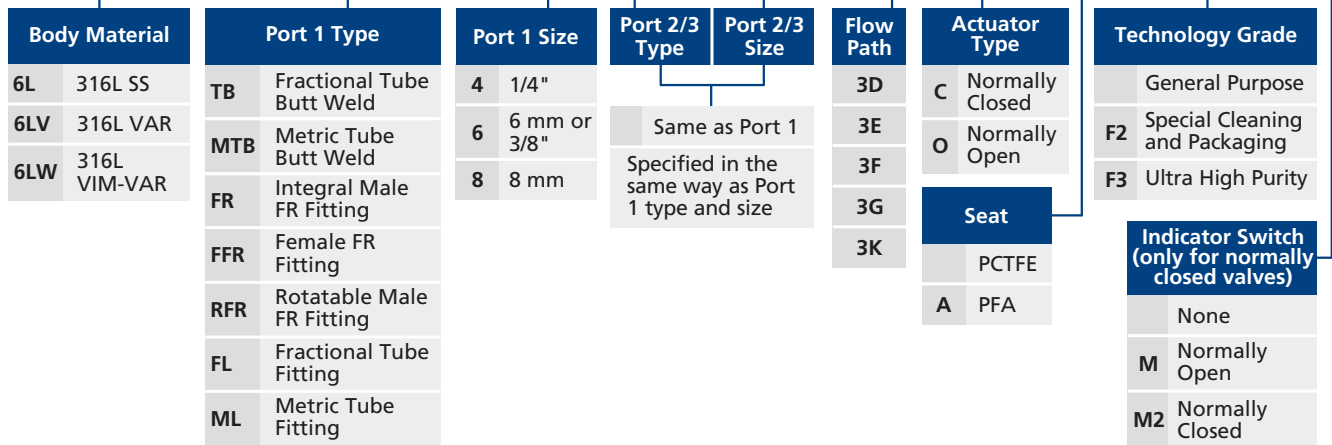

Fittings

Valves & Regulators

2-Valve 3-Way Block Type

Dimensions

Dimensions, in inches (millimeters), are for reference only.

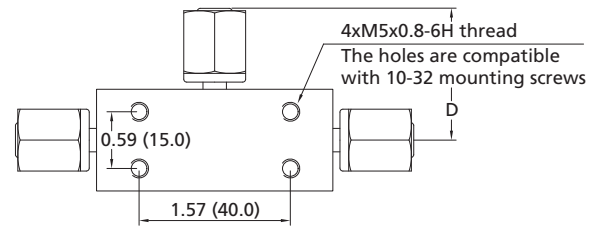
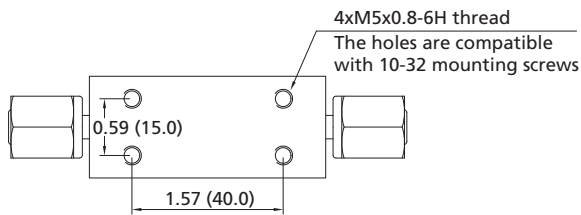
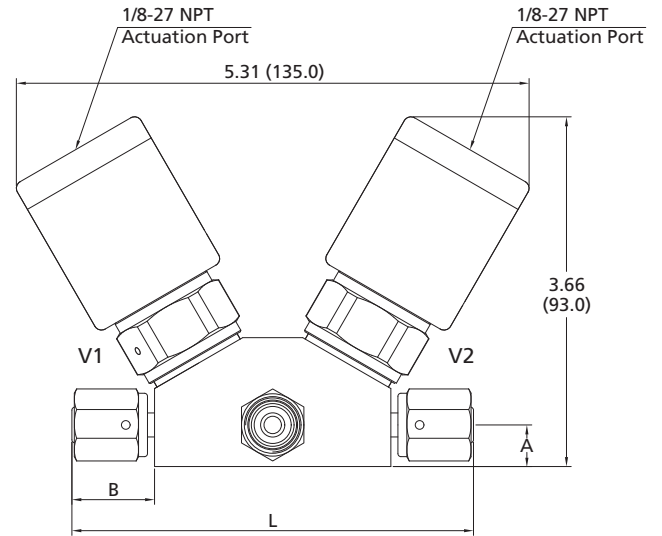
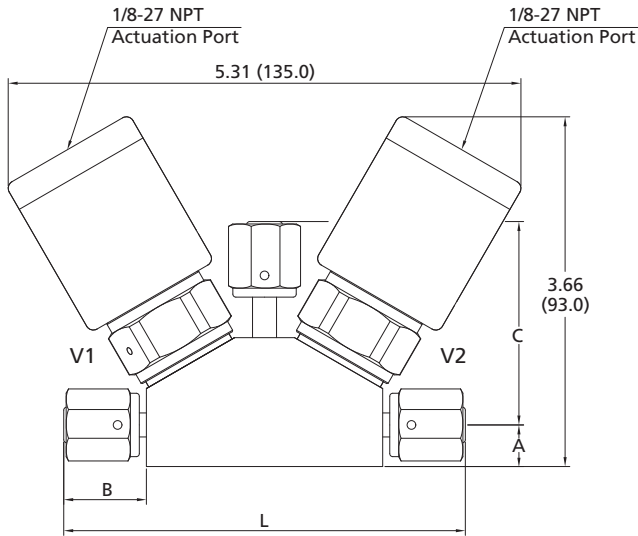

Basic Ordering Number	Connection Type and Size	Dimensions in. (mm)				
		A	B	C	D	L
DP23□□-FFR4-	1/4" Female FR	0.44 (11.2)	0.86 (21.8)	2.12 (53.8)	—	4.24 (107.6)
DP23□□-FFR4-	1/4" Female FR	0.44 (11.2)	0.86 (21.8)	—	1.37 (34.8)	4.24 (107.6)
DP23□□-RFR4-	1/4" Rotatable Male FR	0.44 (11.2)	0.86 (21.8)	2.12 (53.8)	—	4.24 (107.6)
DP23□□-RFR4-	1/4" Rotatable Male FR	0.44 (11.2)	0.86 (21.8)	—	1.37 (34.8)	4.24 (107.6)

Flow Paths

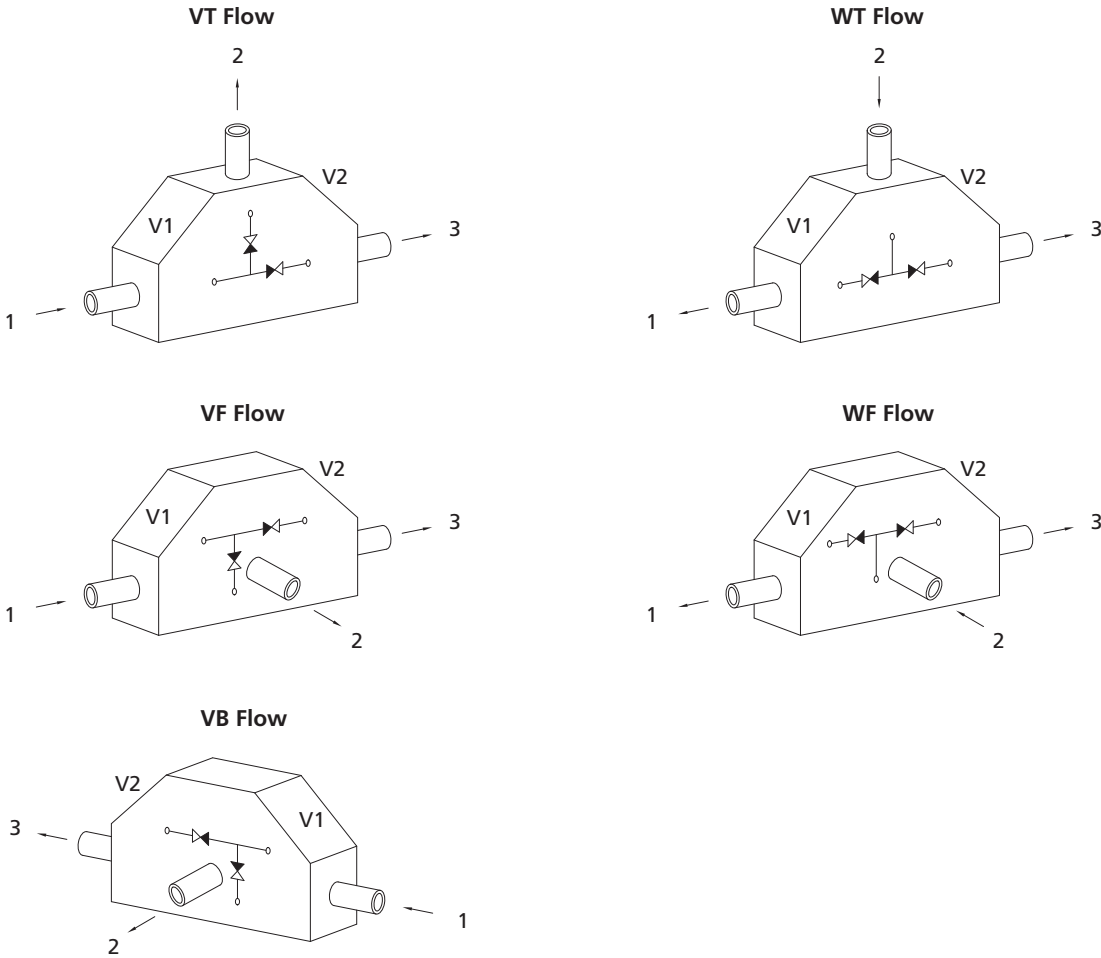

Ordering Number Description

DP236L - FFR4 - RFR4 - FFR4 - VF - COAF2M

Type	Body Material	Port 1 Type	Port 2/3 Type	Port 2/3 Size	Flow Path	Actuator Type V1 and V2	Technology Grade
23 2 Valves and 3 Ports	6L 316L SS 6LV 316L VAR 6LW 316L VIM-VAR	FFR Female FR Fitting RFR Rotatable Male FR Fitting	Same as Port 1	Specified in the same way as Port 1 type and size	VT VF VB WT WF	C V1 Closed V2 Closed O V1 Open V2 Open CO V1 Closed V2 Open OC V1 Open V2 Closed	General Purpose F2 Special Cleaning and Packaging F3 Ultra High Purity
		Port 1 Size 4 1/4"				Seat PCTFE A PFA	Indicator Switch (only for normally closed valves) None M Normally Open M2 Normally Closed

3-Valve 4-Way Block Type

Dimensions

Dimensions, in inches (millimeters), are for reference only.

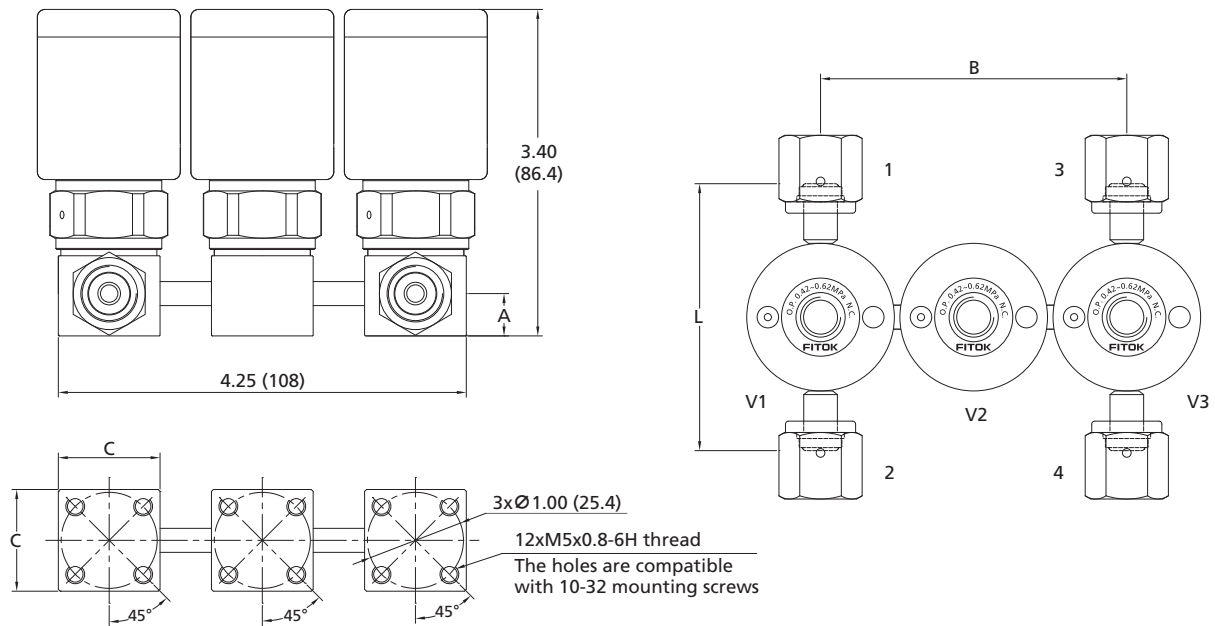

Basic Ordering Number	Connection Type and Size	Dimensions in. (mm)			
		A	B	C	L
DP34□□-FFR4-	1/4" Female FR	0.44 (11.2)	3.19 (81.0)	1.06 (26.9)	2.78 (70.6)
DP34□□-RFR4-	1/4" Rotatable Male FR	0.44 (11.2)	3.19 (81.0)	1.06 (26.9)	2.78 (70.6)

Flow Paths

☉ Flow paths as viewed from the top

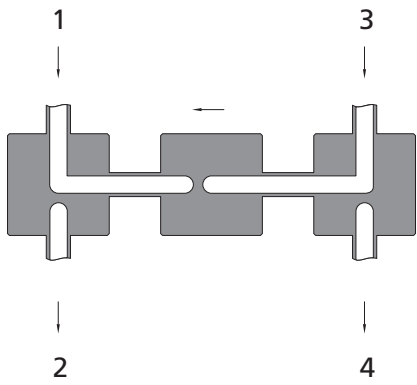

GK Flow

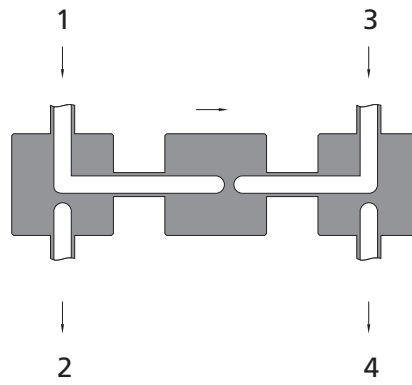

KG Flow

Ordering Number Description

DP346L - FFR4 - RFR4 - FFR4 - FFR4 - GK - CAF3M

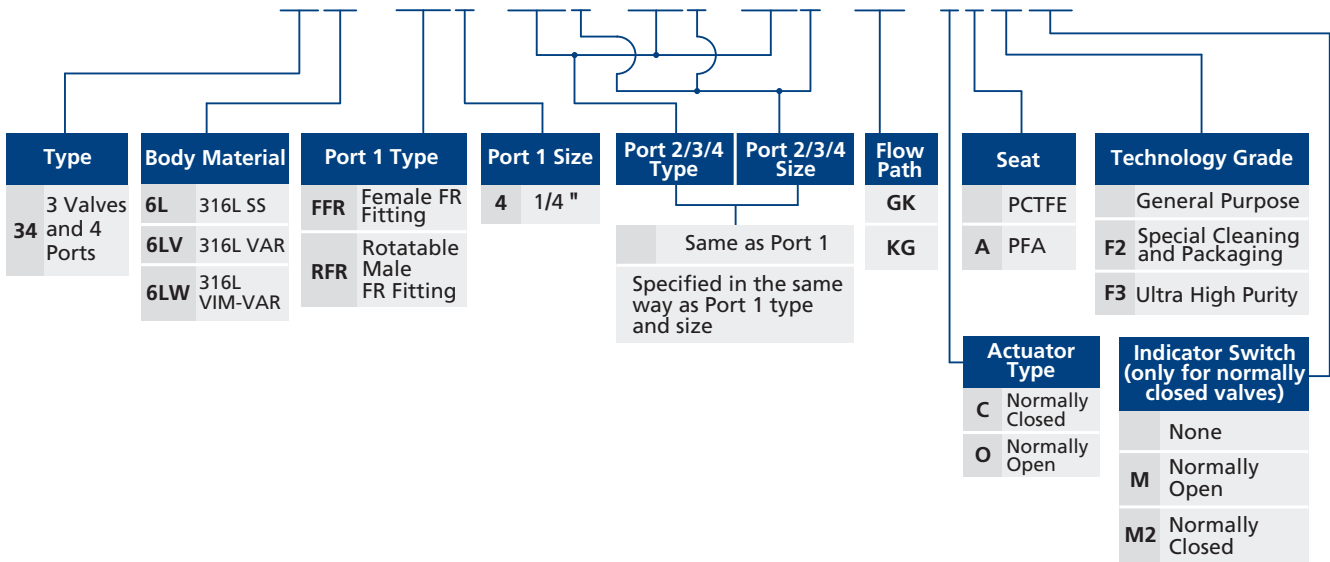

Diaphragm Valves

DH Series High Pressure Springless Diaphragm Valves

Features

- ⦿ Metal-to-metal diaphragm seal
- ⦿ Elgiloy diaphragm to provide high strength and corrosion resistance
- ⦿ Long cycle life in high pressure application
- ⦿ Manual and pneumatic actuators available
- ⦿ Indicator switch available assembled on pneumatic valves, transmitting a signal to an electrical device to indicated either the open or closed position of the valves
- ⦿ Normally open and normally closed indicator switches optional

Technical Data

Port Size	1/4" to 3/8" or 6 mm to 8 mm	
Flow Coefficient (Cv)	0.20	
Orifice Size	0.16 in. (4.1 mm)	
Max. Working Pressure	3000 psig (206 bar)	
Pneumatic Actuator Operating Pressure	60 to 90 psig (4.2 to 6.2 bar)	
Temperature	PCTFE: -10~150°F (-23~65°C)	
Leak rate (Helium)	Internal	≤1x10 ⁻⁹ mbar l/s
	External	≤1x10 ⁻⁹ mbar l/s

Flow Data

Air @ 70°F (21°C)
Water @ 60°F (16°C)

Pressure Drop to Atmosphere psi (bar)	Air (l/min)	Water (l/min)
10 (0.68)	64	2.4
50 (3.4)	170	5.4
100 (6.8)	300	7.6

Product Technology Grade

Product Grade Technology	General Purpose	Special Cleaning and Packaging (F2)	Ultra High Purity (F3)
Material/Specification	316L SS/ASTM A479		316L VAR/SEMI F20 316L VIM-VAR /SEMI F20
Wetted Surface Roughness	Ra 10 μin. (0.25 μm) ^①		Ra 5 μin. (0.13 μm)
Polishing Process	Machine finished ^①		Electropolished
Process Specification	FC-01 Standard Cleaning and Packaging	FC-02 Special Cleaning and Packaging	FC-03 Ultra High Purity Process Specification
Cleaning	Thrice degreasing ultrasonic cleaning	Special cleaning with non-ozone-depleting chemicals	Ultra high purity cleaning in continuously monitored ultrasonic cleaning system with deionized water
Assembly Environment	At atmosphere	In specially cleaned areas	In ISO Class 5/Federal Class 100 cleanroom
Packaging	Individually bagged	Double bagged	Double bagged and vacuum sealed in cleanroom

① For FR connections and tube butt connections, the standard polishing process is electropolishing and the internal surface roughness is finished to an average of Ra 5 μin. (0.13 μm).

Major Materials of Construction

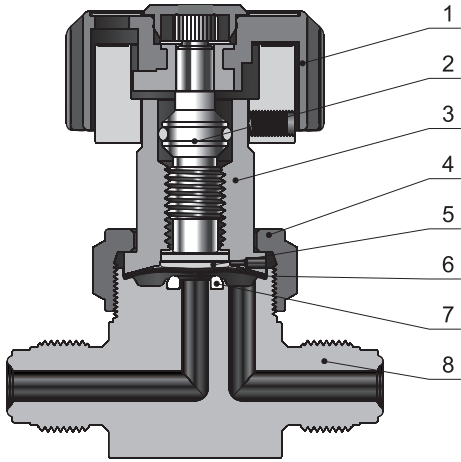

Round Handle Model

Item	Component	Material/Specification
1	Handle	ABS
2	Stem	316 SS/ASTM A479
3	Bonnet	S17400/ASTM A564
4	Bonnet Nut	316 SS/ASTM A479
5	Button	316 SS/ASTM A479
6	Diaphragm (5)	Elgiloy(3)/AMS 5876 + C17200(2)/ASTM B194
7	Seat	PCTFE/ASTM D1430
8	Body	316 SS/ASTM A479 or 316L SS/ASTM A479 or 316L VIM-VAR/SEMI F20

Actuators

Manual - Round Handle

- ⦿ Quick, quarter-turn actuation
- ⦿ Handle with window to visually indicate open and closed states

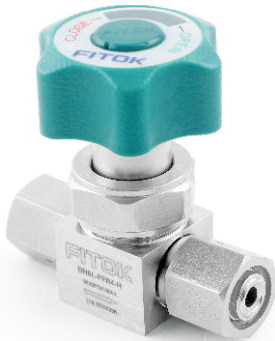

Pneumatic

- ⦿ Normally open, "N.O." marked on the top of the cylinder
- ⦿ Normally closed, "N.C." marked on the top of the cylinder



Dimensions and Ordering Information

Straight Type

Dimensions

Dimensions, in inches (millimeters), are for reference only.

Manual - Round Handle

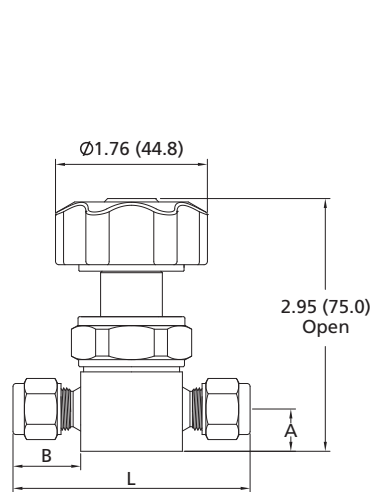

Pneumatic

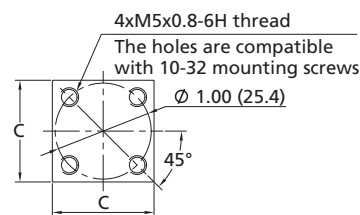
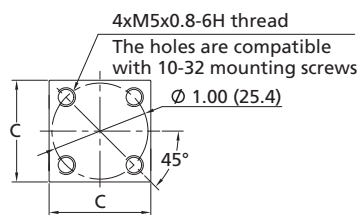
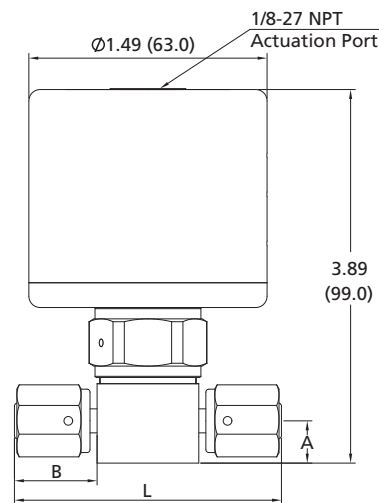

Basic Ordering Number	Connection Type and Size	Dimensions in. (mm)			
		A	B	C	L
DH□□-TB4-	1/4" Tube Butt Weld	0.44 (11.2)	0.30 (7.6)	1.06 (26.9)	1.74 (44.2)
DH□□-TB6-	3/8" Tube Butt Weld	0.44 (11.2)	0.26 (6.6)	1.06 (26.9)	1.74 (44.2)
DH□□-FFR4-	1/4" Female FR	0.44 (11.2)	0.86 (21.8)	1.06 (26.9)	2.78 (70.6)
DH□□-RFR4-	1/4" Rotatable Male FR	0.44 (11.2)	0.86 (21.8)	1.06 (26.9)	2.78 (70.6)
DH□□-FR4-	1/4" Integral Male FR	0.44 (11.2)	0.62 (15.7)	1.06 (26.9)	2.30 (58.4)
DH□□-ML6-	6 mm FITOK Tube Fitting	0.44 (11.2)	0.70 (17.9)	1.06 (26.9)	2.47 (62.7)

Ordering Number Description

DH6L - FL4 - ML6 - CF2M

Body Material		Inlet Type		Inlet Size		Outlet Type	Outlet Size	Actuator Type		Technology Grade		
6L	316L SS	TB	Fractional Tube Butt Weld	4	1/4"	Same as Inlet	Specified in the same way as Inlet type and size	R	Handle	General Purpose		
6LV	316L VAR	MTB	Metric Tube Butt Weld	6	6 mm or 3/8"			C	Pneumatic Normally Closed	F2	Special Cleaning and Packaging	
6LW	316L VIM-VAR	FR	Integral Male FR Fitting	8	8 mm			O	Pneumatic Normally Open	F3	Ultra High Purity	
		FFR	Female FR Fitting					Note: For butt weld connection, pneumatic actuator is not recommended unless it causes no interference to welding.		Indicator Switch (only for pneumatic valves)		
		RFR	Rotatable Male FR Fitting							None		
		FL	Fractional Tube Fitting							M		Normally Open
		ML	Metric Tube Fitting							M2		Normally Closed

Branch Type

Dimensions

Dimensions, in inches (millimeters), are for reference only.

Manual - Round Handle

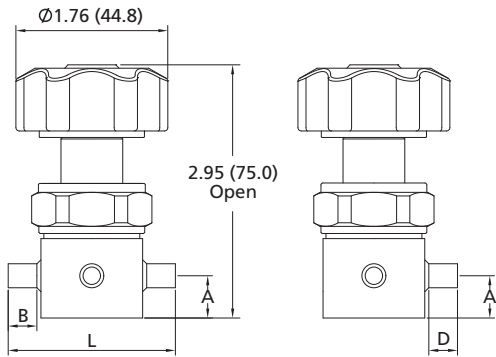

Pneumatic

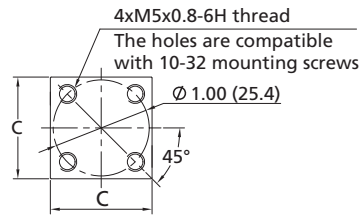
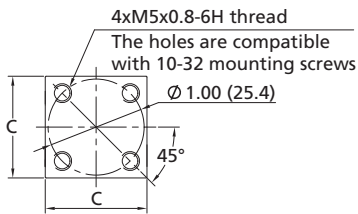
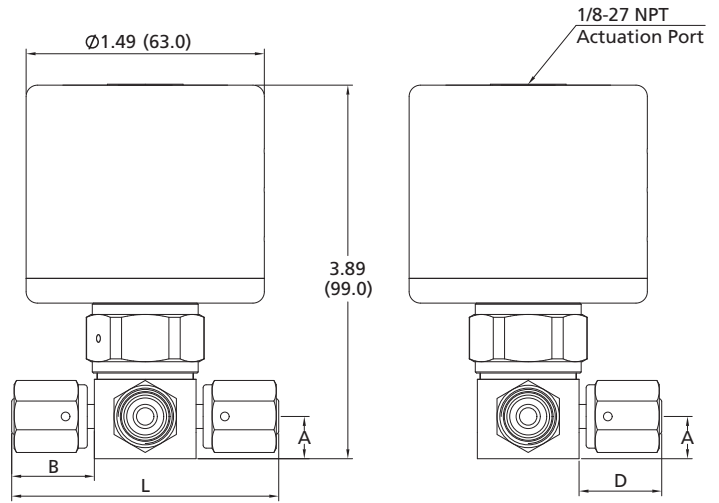

Basic Ordering Number	Connection Type and Size	Dimensions in. (mm)				
		A	B	C	D	L
DH□□-TB4-	1/4" Tube Butt Weld	0.44 (11.2)	0.30 (7.6)	1.06 (26.9)	0.30 (7.6)	1.74 (44.2)
DH□□-TB6-	3/8" Tube Butt Weld	0.44 (11.2)	0.26 (6.6)	1.06 (26.9)	0.26 (6.6)	1.74 (44.2)
DH□□-FFR4-	1/4" Female FR	0.44 (11.2)	0.86 (21.8)	1.06 (26.9)	0.86 (21.8)	2.78 (70.6)
DH□□-RFR4-	1/4" Rotatable Male FR	0.44 (11.2)	0.86 (21.8)	1.06 (26.9)	0.86 (21.8)	2.78 (70.6)
DH□□-FR4-	1/4" Integral Male FR	0.44 (11.2)	0.62 (15.7)	1.06 (26.9)	0.62 (15.7)	2.30 (58.4)
DH□□-FL4-	1/4" FITOK Tube Fitting	0.44 (11.2)	0.70 (17.9)	1.06 (26.9)	0.70 (17.9)	2.47 (62.7)

Flow Paths

☉ Flow paths as viewed from the top

3D Flow

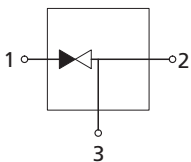

3E Flow

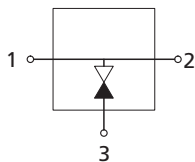

3F Flow

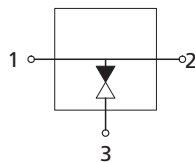

3G Flow

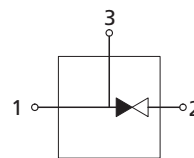

3K Flow

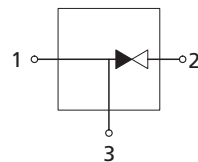

Ordering Number Description

DH6L - TB4 - TB4 - FR4 - 3F - CF2M

Fittings

Valves & Regulators

Body Material		Port 1 Type		Port 1 Size		Port 2/3 Type	Port 2/3 Size	Flow Path	Actuator Type		Technology Grade		
6L	316L SS	TB	Fractional Tube Butt Weld	4	1/4"	Same as Port 1	Specified in the same way as Port 1 type and size	3D	R	Handle	General Purpose		
6LV	316L VAR	MTB	Metric Tube Butt Weld	6	6 mm or 3/8"			3E	C	Pneumatic Normally Closed	F2	Special Cleaning and Packaging	
6LW	316L VIM-VAR	FR	Male FR Fitting	8	8 mm			3F	O	Pneumatic Normally Open	F3	Ultra High Purity	
		FFR	Female FR Fitting					3G	Note: For butt weld connection, pneumatic actuator is not recommended unless it causes no interference to welding.			Indicator Switch (only for pneumatic valves)	
		RFR	Rotatable Male FR Fitting					3K				None	
		FL	Fractional Tube Fitting									M	Normally Open
		ML	Metric Tube Fitting								M2	Normally Closed	

Diaphragm Valves

DM Series High Pressure Spring Diaphragm Valves

Features

- ⦿ All-metal containment, packless
- ⦿ Repetitive shutoff with fully contained soft-seat stem tip
- ⦿ Position indicator ring for lever handle
- ⦿ Reduced seat volume
- ⦿ Fully functional under vacuum conditions
- ⦿ Different handle types and pneumatic actuators available
- ⦿ Indicator switch available assembled on pneumatic valves, transmitting a signal to an electrical device to indicated either the open or closed position of the valves
- ⦿ Normally open and normally closed indicator switches optional

Technical Data

Port Size		1/4" to 3/8" or 6 mm to 8 mm
Flow Coefficient (Cv)	Lever Handle	0.14
	Round Handle	0.30
	Pneumatic Actuator	0.20
Orifice Size		0.16 in. (4.1 mm)
Max. Working Pressure		3500 psig (241 bar)
Max. Differential Back Pressure ^①		1500 psig (103 bar)
Pneumatic Actuator Operating Pressure		60 to 90 psig (4.2 to 6.2 bar)
Temperature		PCTFE: -100~250°F (-73~121°C) Vespel: -100~320°F (-73~160°C)
Leak Rate (Helium)	Internal	≤4x10 ⁻⁹ mbar l/s
	External	≤4x10 ⁻⁹ mbar l/s

① A 17-7 stainless steel spring is available to increase the rating to 2500 psig (172 bar). To order, please contact FITOK group or our authorized distributors.

Flow Data

Air @ 70°F (21°C)

Water @ 60°F (16°C)

Pressure Drop to Atmosphere psi (bar)	Lever Handle		Round Handle		Pneumatic Actuator	
	Air (l/min)	Water (l/min)	Air (l/min)	Water (l/min)	Air (l/min)	Water (l/min)
10 (0.68)	49	1.6	100	3.5	64	2.4
50 (3.4)	130	3.9	270	8.0	170	5.4
100 (6.8)	240	5.4	490	11.4	300	7.6

Product Technology Grade

Product Grade Technology	General Purpose	Special Cleaning and Packaging (F2)	Ultra High Purity (F3)
Material/Specification	316 SS/ASTM A479 or 316L SS/ASTM A479		316L SS/ASTM A479
Wetted Surface Roughness	Ra 20 µin. (0.51 µm)		Ra 10 µin. (0.25 µm)
Polishing Process	Machine finished		Electropolished
Process Specification	FC-01 Standard Cleaning and Packaging	FC-02 Special Cleaning and Packaging	FC-03 Ultra High Purity Process Specification
Cleaning	Thrice degreasing ultrasonic cleaning	Special cleaning with non-ozone-depleting chemicals	Ultra high purity cleaning in continuously monitored ultrasonic cleaning system with deionized water
Assembly Environment	At atmosphere	In specially cleaned areas	In ISO Class 5/Federal Class 100 cleanroom
Packaging	Individually bagged	Double bagged	Double bagged and vacuum sealed in cleanroom

Major Materials of Construction

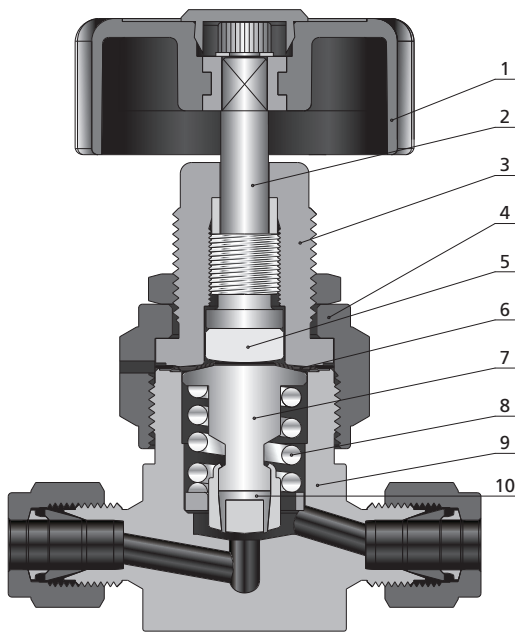

Round Handle Model

Item	Component	Material/Specification
1	Handle	ABS or Aluminum
2	Actuator	416 SS/ASTM A582
3	Bonnet	316 SS/ASTM A479
4	Bonnet Nut	316 SS/ASTM A479
5	Button	C36000/ASTM B16
6	Diaphragm (3)	Elgiloy/AMS 5876
7	Stem	316L SS/ASTM A479
8	Spring	316 SS/ASTM A313
9	Body	316 SS/ASTM A479 or 316L SS/ASTM A479
10	Seat	PCTFE/ASTM D1430 or Vespel

Actuators

Manual - Lever Handle

- ⦿ Quick, quarter-turn actuation
- ⦿ Position indicator ring to visually indicate open and closed states



Manual - Round Handle

- ⦿ One and a half turns to operate from fully open to closed



Pneumatic

- ⦿ Normally open, "N.O." marked on the top of the cylinder
- ⦿ Normally closed, "N.C." marked on the top of the cylinder



Dimensions and Ordering Information

Straight Type

Dimensions

Dimensions, in inches (millimeters), are for reference only.

Manual - Round Handle

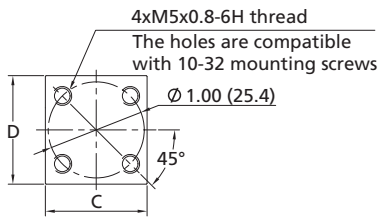
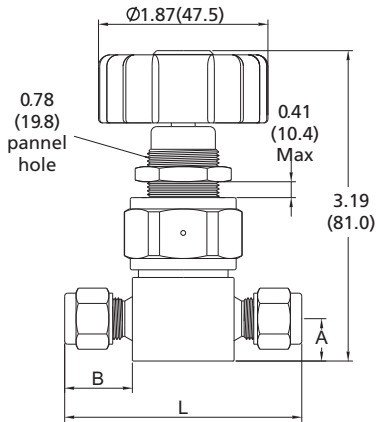

Manual - Lever Handle

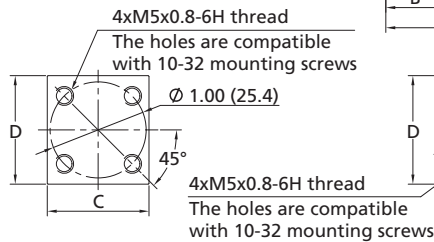
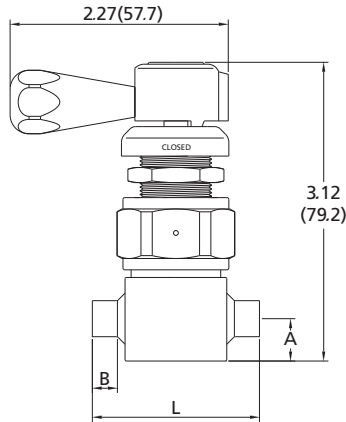

Pneumatic

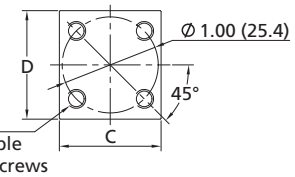
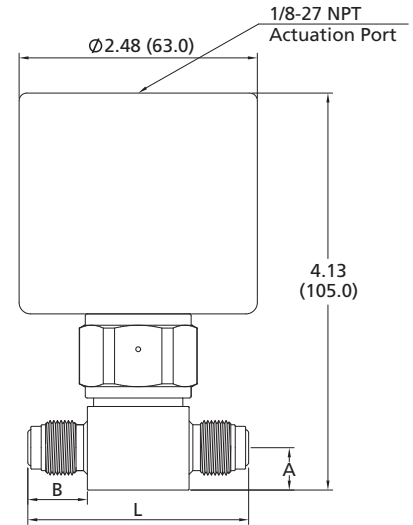

Basic Ordering Number	Connection Type and Size	Dimensions in. (mm)				
		A	B	C	D	L
DM□□-FL4-	1/4" FITOK Tube Fitting	0.44 (11.2)	0.70 (17.9)	1.06 (26.9)	1.13 (28.7)	2.46 (62.5)
DM□□-FL6-	3/8" FITOK Tube Fitting	0.44 (11.2)	0.76 (19.3)	1.06 (26.9)	1.13 (28.7)	2.58 (65.5)
DM□□-ML6-	6 mm FITOK Tube Fitting	0.44 (11.2)	0.70 (17.9)	1.06 (26.9)	1.13 (28.7)	2.46 (62.5)
DM□□-ML8-	8 mm FITOK Tube Fitting	0.44 (11.2)	0.74 (18.7)	1.06 (26.9)	1.13 (28.7)	2.53 (64.3)
DM□□-TB4-	1/4" Tube Butt Weld	0.44 (11.2)	0.30 (7.6)	1.06 (26.9)	1.13 (28.7)	1.74 (44.2)
DM□□-TB6-	3/8" Tube Butt Weld	0.44 (11.2)	0.26 (6.6)	1.06 (26.9)	1.13 (28.7)	1.74 (44.2)
DM□□-NS4-	1/4" Integral Male FR	0.44 (11.2)	—	1.06 (26.9)	1.13 (28.7)	2.46 (62.5)
DM□□-FNS4-	1/4" Female NPT	0.44 (11.2)	—	1.06 (26.9)	1.13 (28.7)	2.46 (62.5)
DM□□-FR4-	1/4" Male FR	0.44 (11.2)	0.62 (15.7)	1.06 (26.9)	1.13 (28.7)	2.30 (58.4)
DM□□-FFR4-	1/4" Female FR	0.44 (11.2)	0.85 (21.6)	1.06 (26.9)	1.13 (28.7)	2.76 (70.1)
DM□□-FO4-	1/4" Male FO	0.44 (11.2)	0.47 (11.9)	1.06 (26.9)	1.13 (28.7)	2.00 (50.8)

Angle Type

Dimensions

Dimensions, in inches (millimeters), are for reference only.

Manual - Round Handle

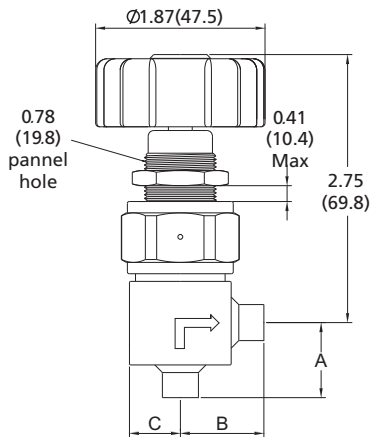

Manual - Lever Handle

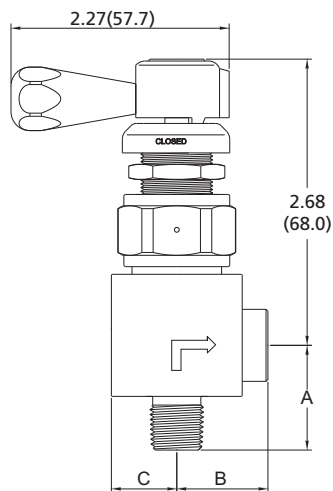

Pneumatic

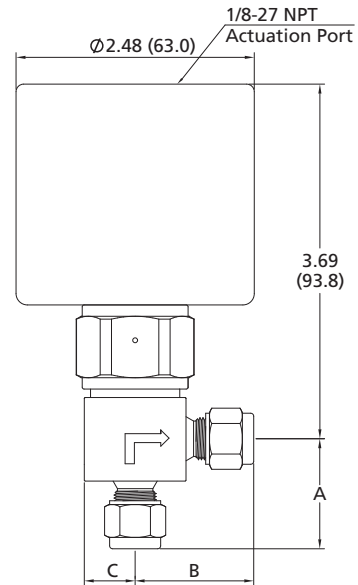

Basic Ordering Number	Connection Type and Size	Dimensions in. (mm)		
		A	B	C
DM□□-FL4-	1/4" FITOK Tube Fitting	1.14 (29.1)	1.23 (31.3)	0.53 (13.4)
DM□□-ML6-	6 mm FITOK Tube Fitting	1.14 (29.1)	1.23 (31.3)	0.53 (13.4)
DM□□-TB6-	3/8" Tube Butt Weld	0.78 (19.8)	0.87 (22.0)	0.53 (13.4)
DM□□-NS4-FNS4	Inlet 1/4" Male NPT	1.09 (27.7)	0.95 (24.1)	0.68 (17.3)
	Outlet 1/4" Female NPT			

Ordering Number Description

DMSS - FL4 - ML6 - A - CVF2M

Body Material		Inlet Type		Outlet Type	Outlet Size	Actuator Type		Stem Tip Material	Technology Grade		
6L	316L SS	TB	Fractional Tube Butt Weld	Same as Inlet	Specified in the same way as Inlet type and size	R	Round Handle	PCTFE	F2	General Purpose	
SS	316 SS	MTB	Metric Tube Butt Weld			L	Lever Handle	V	Vespel	F3	Special Cleaning and Packaging
		FR	Integral Male FR Fitting			C	Pneumatic Normally Closed			F3	Ultra High Purity
		FFR	Female FR Fitting			O	Pneumatic Normally Open				
		FL	Fractional Tube Fitting	Inlet Size	Flow Path	Note: For butt weld connection, pneumatic actuator is not recommended unless it causes no interference to welding.					
		ML	Metric Tube Fitting	4	1/4"						
		NS	Male NPT	6	6 mm or 3/8"						
		FNS	Female NPT	8	8 mm or 1/2"						
					A	Indicator Switch (only for pneumatic valves)					
						None					
						M Normally Open					
						M2 Normally Closed					

Branch Type

Dimensions

Dimensions, in inches (millimeters), are for reference only.

Manual - Round Handle

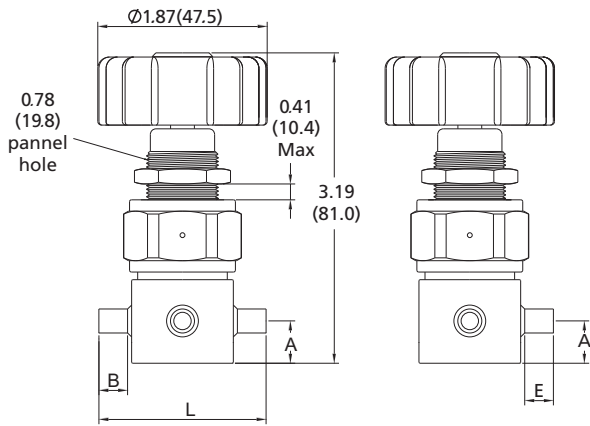

Pneumatic

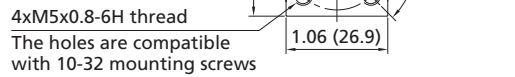
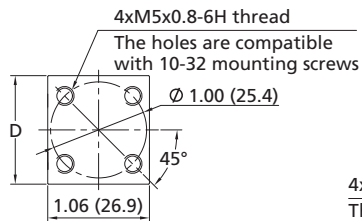
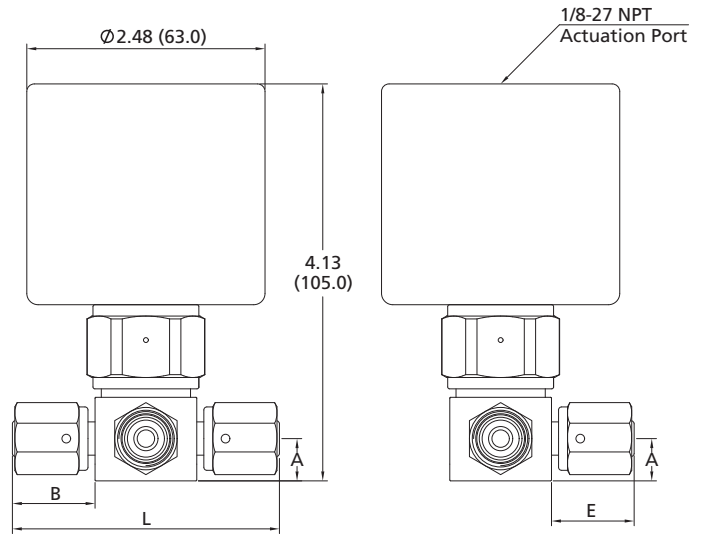

Basic Ordering Number	Connection Type and Size	Dimensions in. (mm)				
		A	B	D	E	L
DM□□-TB4-	1/4" Tube Butt Weld	0.44 (11.2)	0.30 (7.6)	1.13 (28.7)	0.30 (7.6)	1.74 (44.2)
DM□□-MTB6-	6 mm Tube Butt Weld	0.44 (11.2)	0.30 (7.6)	1.13 (28.7)	0.30 (7.6)	1.74 (44.2)
DM□□-FFR4-	1/4" Female FR	0.44 (11.2)	0.85 (21.6)	1.13 (28.7)	0.85 (21.6)	2.76 (70.1)
DM□□-RFR4-	1/4" Rotatable Male FR	0.44 (11.2)	1.21 (30.7)	1.13 (28.7)	1.21 (30.7)	3.48 (88.4)

Flow Paths

☉ Flow paths as viewed from the top

3D Flow

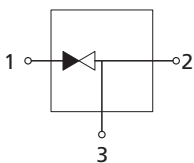

3E Flow

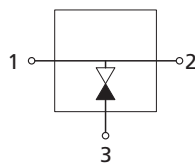

3F Flow

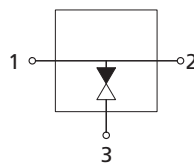

3G Flow

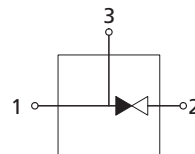

3K Flow

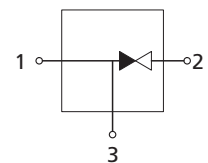

Ordering Number Description

DMSS - TB4 - TB4 - FFR4 - 3F - LVF2M

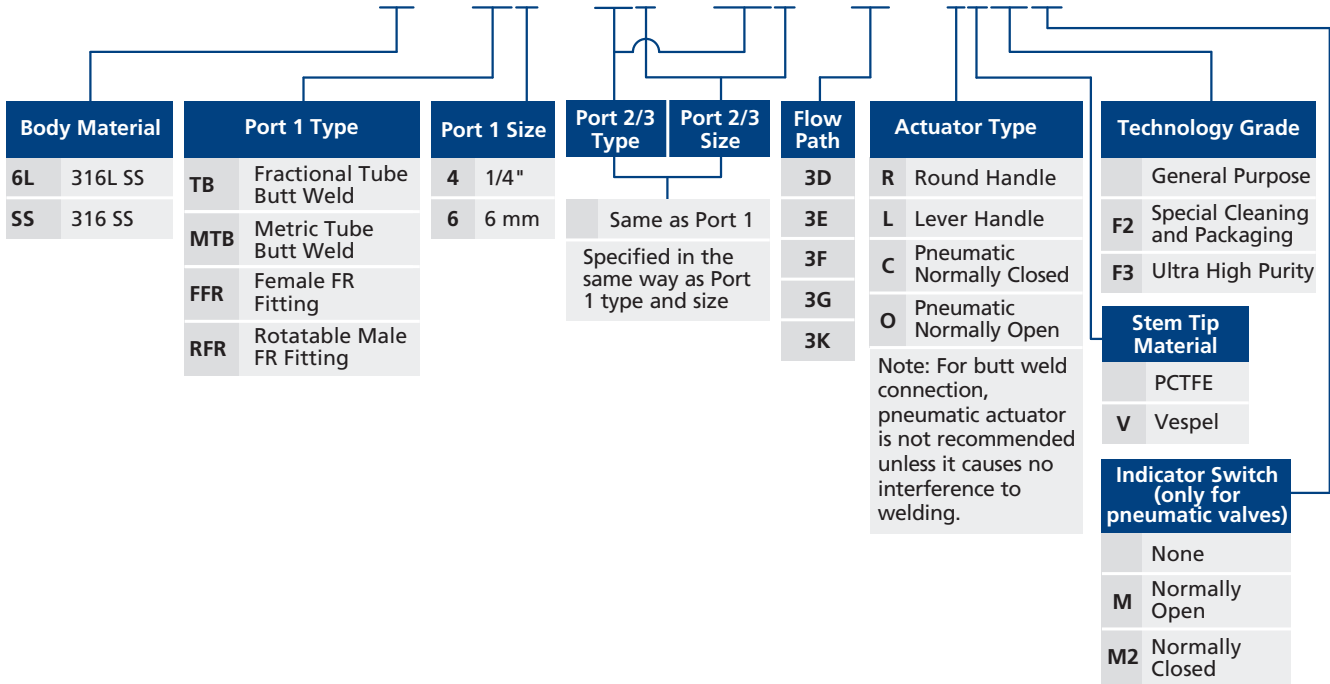

Fittings

Valves & Regulators

Diaphragm Valves

DS Series High Pressure Compact Diaphragm Valves

Features

- ⦿ Reduced inner volume
- ⦿ Packless diaphragm seal to ensure high purity
- ⦿ Minimized number of components
- ⦿ Manual and pneumatic actuators available
- ⦿ Aluminum piston to increase operation speed

Technical Data

Port Size			1/4" to 3/8" or 6 mm to 8 mm
Flow Coefficient (Cv)			0.17
Orifice Size			0.12 in. (3.0 mm)
Max. Working Pressure	Manual	4500 psig (310 bar)	
	Pneumatic	3000 psig (206 bar)	
Pneumatic Actuator Operating Pressure			60 to 90 psig (4.2 to 6.2 bar)
Temperature			PCTFE: -10~150°F (-23~65°C) VespeI: -10~250°F (-23~121°C)
Leak Rate (Helium)	Internal	≤ 1x10 ⁻⁹ mbar l/s	
	External	≤ 1x10 ⁻⁹ mbar l/s	

Flow Data

Air @ 70°F (21°C)
Water @ 60°F (16°C)

Pressure Drop to Atmosphere psi (bar)	Air (l/min)	Water (l/min)
10 (0.68)	55	1.9
50 (3.4)	150	4.5
100 (6.8)	260	6.4

Product Technology Grade

Product Grade	General Purpose	Special Cleaning and Packaging (F2)	Ultra High Purity (F3)
Material/Specification	316 SS/ASTM A479 316L SS/ASTM A479		316L VAR/SEMI F20 316L VIM-VAR /SEMI F20
Wetted Surface Roughness	Ra 20 µin. (0.51 µm)		Ra 10 µin. (0.25 µm)
Polishing Process	Machine finished		Electropolished
Process Specification	FC-01 Standard Cleaning and Packaging	FC-02 Special Cleaning and Packaging	FC-03 Ultra High Purity Process Specification
Cleaning	Thrice degreasing ultrasonic cleaning	Special cleaning with non-ozone-depleting chemicals	Ultra high purity cleaning in continuously monitored ultrasonic cleaning system with deionized water
Assembly Environment	At atmosphere	In specially cleaned areas	In ISO Class 5/Federal Class 100 cleanroom
Packaging	Individually bagged	Double bagged	Double bagged and vacuum sealed in cleanroom

Major Materials of Construction

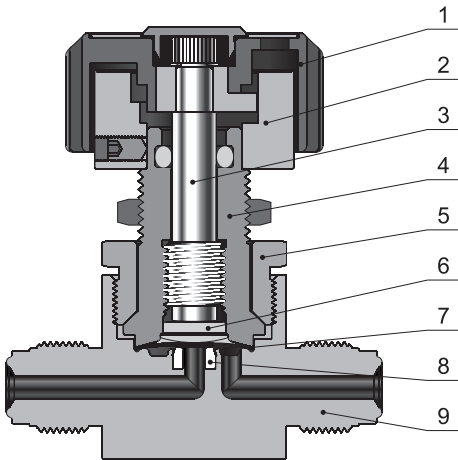

Round Handle Model

Item	Component	Material/Specification
1	Handle	ABS
2	Actuator	Aluminum
3	Stem	316 SS/ASTM A479
4	Bonnet	S17400/ASTM A564
5	Bonnet Nut	316 SS/ASTM A479
6	Button	C36000/B16
7	Diaphragm (5)	Elgiloy (3) /AMS 5876 + C17200 (2) /ASTM B194
8	Seat	PCTFE/ASTM D1430 or Vespel
9	Body	316 SS/ASTM A479 or 316L SS/ASTM A479 or 316L VIM-VAR/SEMI F20

Actuators

Manual - Round Handle

- ⦿ Quick, quarter-turn actuation
- ⦿ Handle with window to visually indicate open and closed states



Pneumatic

- ⦿ Normally open, "N.O." marked on the top of the cylinder
- ⦿ Normally closed, "N.C." marked on the top of the cylinder



2-Valve 3-Way Block Type

Dimensions

Dimensions, in inches (millimeters), are for reference only.

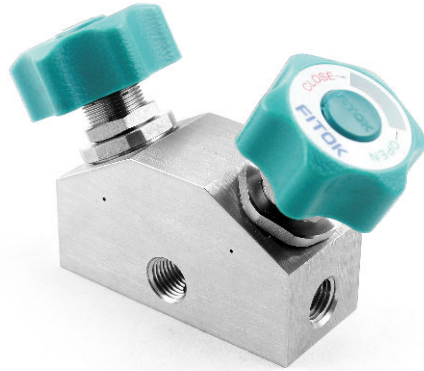

Manual - Round Handle

Pneumatic

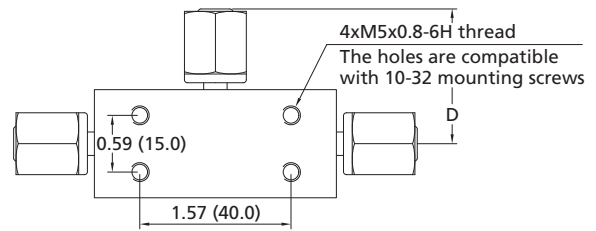
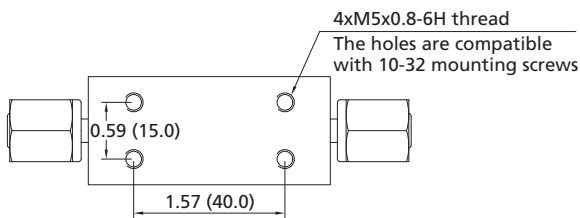
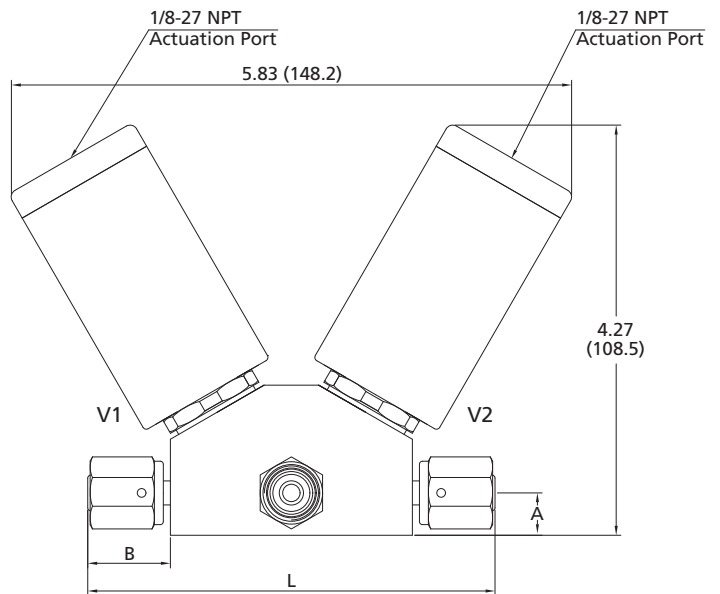
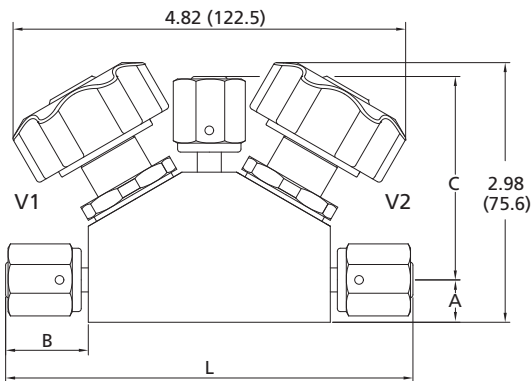

Basic Ordering Number	Connection Type and Size	Dimensions in. (mm)				
		A	B	C	D	L
DS23□□-FFR4-	1/4" Female FR	0.44 (11.2)	0.86 (21.8)	2.59 (65.7)	—	4.24 (107.6)
DS23□□-FFR4-	1/4" Female FR	0.44 (11.2)	0.86 (21.8)	—	1.54 (39.1)	4.24 (107.6)
DS23□□-FNS4-	1/4" Female NPT	0.44 (11.2)	—	—	0.68 (17.3)	3.07 (78.0)

Flow Paths

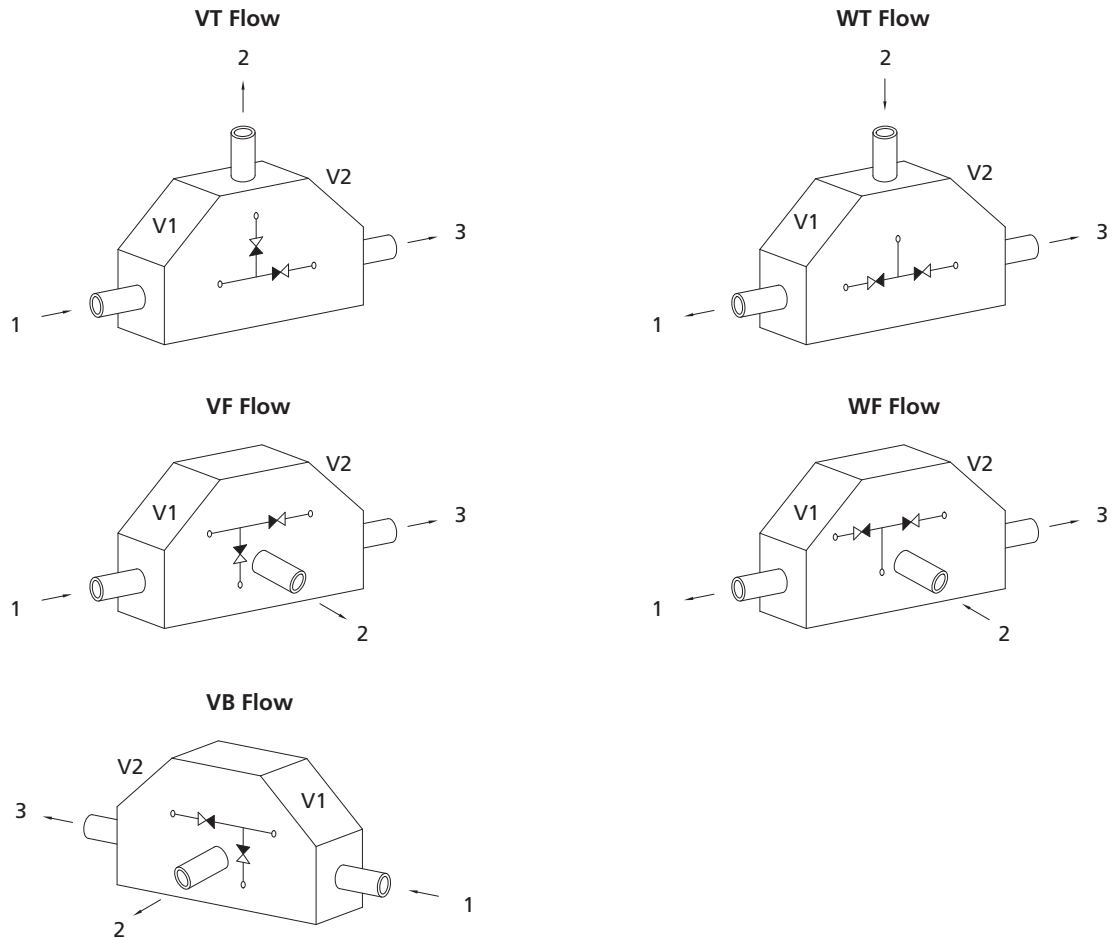

Ordering Number Description

DS236L - FFR4RFR4 - FFR4 - VF - COVF2

Type	Port 1 Type	Port 2/3 Type	Port 2/3 Size	Flow Path	Actuator Type V1 and V2	Technology Grade
23 2 Valves and 3 Ports	FFR Female FR Fitting	Same as Port 1	Specified in the same way as Port 1 type and size	VT	R All Handles	General Purpose
	RFR Rotatable Male FR Fitting			VF	C Pneumatic all Closed	F2 Special Cleaning and Packaging
	FNS Female NPT			VB	O Pneumatic all Open	F3 Ultra High Purity
				WT	RC V1 Handle V2 Closed	Seat
				WF	RO V1 Handle V2 Open	
					CR V1 Closed V2 Handle	V Vespel
					OR V1 Open V2 Handle	
					CO V1 Closed V2 Open	
					OC V1 Open V2 Closed	

Body Material	Port 1 Size
6L 316L SS	4 1/4"
6LV 316L VAR	
6LW 316L VIM-VAR	
SS 316 SS	

Diaphragm Valves

DR Series Low Pressure/Medium Flow Diaphragm Valves

Features

- ⦿ For medium flow applications
- ⦿ Minimum particle generation and dead space
- ⦿ Fully contained seat to provide excellent resistance to swelling and contamination
- ⦿ Elgiloy diaphragm to provide high strength and corrosion resistance to ensure long cycle life
- ⦿ Manual and pneumatic actuators available
- ⦿ Indicator switch available assembled on normally closed valves, transmitting a signal to an electrical device to indicated either the open or closed position of the valves

Technical Data

Port Size	3/8" to 1/2" or 10 mm to 12 mm	
Flow Coefficient (Cv)	0.70	
Orifice Size	0.31 in. (7.9 mm)	
Max. Working Pressure	145 psig (10 bar)	
Pneumatic Actuator Operating Pressure	60 to 90 psig (4.2 to 6.2 bar)	
Temperature	PCTFE: -10~150°F (-23~65°C) PFA: -10~302°F (-23~150°C)	
Leak Rate (Helium)	Internal	$\leq 1 \times 10^{-9}$ mbar l/s
	External	$\leq 1 \times 10^{-9}$ mbar l/s

Flow Data

Air @ 70°F (21°C)

Water @ 60°F (16°C)

Pressure Drop to Atmosphere psi (bar)	Air (l/min)	Water (l/min)
10 (0.68)	240	8.4
50 (3.4)	630	18.6
100 (6.8)	1120	26.6

Product Technology Grade

Product Grade Technology	General Purpose	Special Cleaning and Packaging (F2)	Ultra High Purity (F3)
Material/Specification	316L SS/ASTM A479		316L VAR/SEMI F20 316L VIM-VAR /SEMI F20
Wetted Surface Roughness	Ra 10 μ m. (0.25 μ m) ^①		Ra 5 μ m. (0.13 μ m)
Polishing Process	Machine finished ^①		Electropolished
Process Specification	FC-01 Standard Cleaning and Packaging	FC-02 Special Cleaning and Packaging	FC-03 Ultra High Purity Process Specification
Cleaning	Thrice degreasing ultrasonic cleaning	Special cleaning with non-ozone-depleting chemicals	Ultra high purity cleaning in continuously monitored ultrasonic cleaning system with deionized water
Assembly Environment	At atmosphere	In specially cleaned areas	In ISO Class 5/Federal Class 100 cleanroom
Packaging	Individually bagged	Double bagged	Double bagged and vacuum sealed in cleanroom

① For FR connections and tube butt connections, the standard polishing process is electropolishing and the internal surface roughness is finished to an average of Ra 5 μ m. (0.13 μ m).

Major Materials of Construction

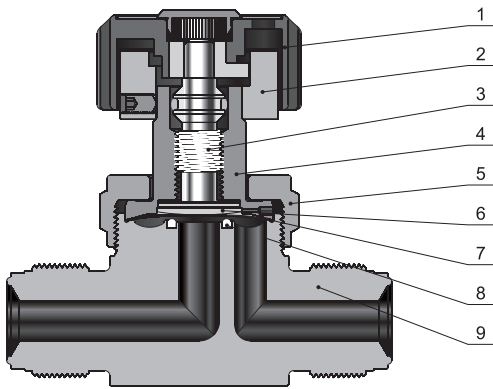

Round Handle Model

Item	Component	Material/Specification
1	Handle	ABS
2	Actuator	Aluminum
3	Stem	316 SS/ASTM A479
4	Bonnet	S17400/ASTM A564
5	Bonnet Nut	316 SS/ASTM A479
6	Button	316 SS/ASTM A479
7	Diaphragm (2)	Elgiloy/AMS 5876
8	Seat	PCTFE/ASTM D1430 or PFA/ASTM D3307
9	Body	316 SS/ASTM A479 or 316L SS/ASTM A479 or 316L VIM-VAR/SEMI F20

Actuators

Manual - Round Handle

- ⦿ Quick, quarter-turn actuation
- ⦿ Handle with windows to visually indicate open and closed states

Pneumatic

- ⦿ Normally open, "N.O." marked on the top of the cylinder
- ⦿ Normally closed, "N.C." marked on the top of the cylinder



Dimensions and Ordering Information

Straight Type

Dimensions

Dimensions, in inches (millimeters), are for reference only.

Manual - Round Handle

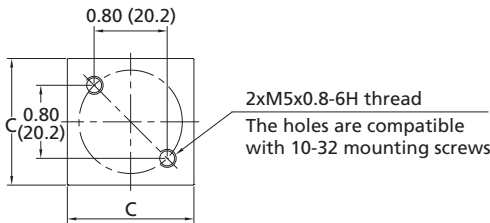
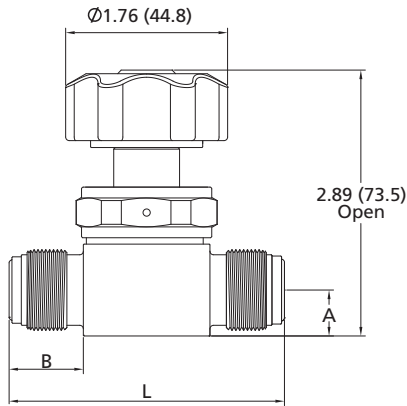

Pneumatic

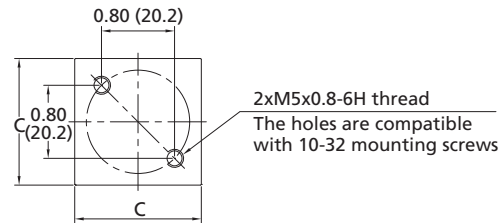
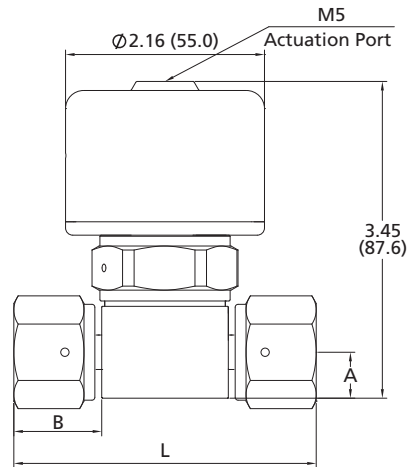

Basic Ordering Number	Connection Type and Size	Dimensions in. (mm)			
		A	B	C	L
DR□□-TB6-	3/8" Tube Butt Weld	0.50 (12.7)	0.67 (17.0)	1.38 (35.0)	2.72 (69.0)
DR□□-TB8-	1/2" Tube Butt Weld	0.50 (12.7)	0.67 (17.0)	1.38 (35.0)	2.72 (69.0)
DR□□-FFR8-	1/2" Female FR	0.50 (12.7)	0.94 (24.0)	1.38 (35.0)	3.27 (83.0)
DR□□-FR8-	1/2" Integral Male FR	0.50 (12.7)	0.81 (20.6)	1.38 (35.0)	3.00 (76.2)

Ordering Number Description

DR6L - FFR8 - RFR8 - RAF3M

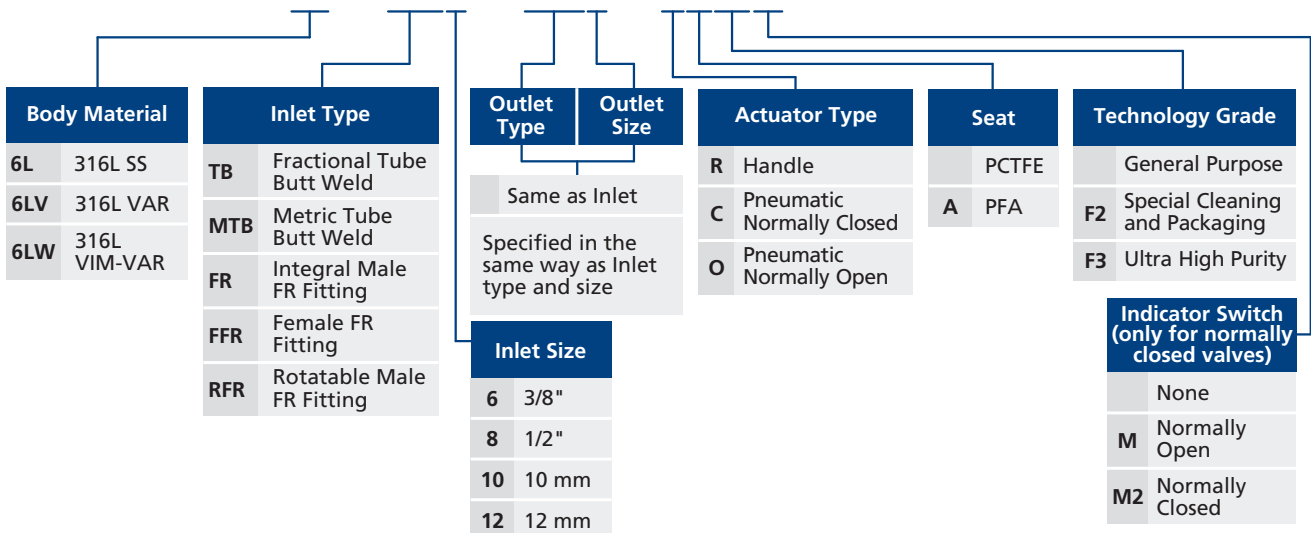

Branch Type

Dimensions

Dimensions, in inches (millimeters), are for reference only.

Manual - Round Handle

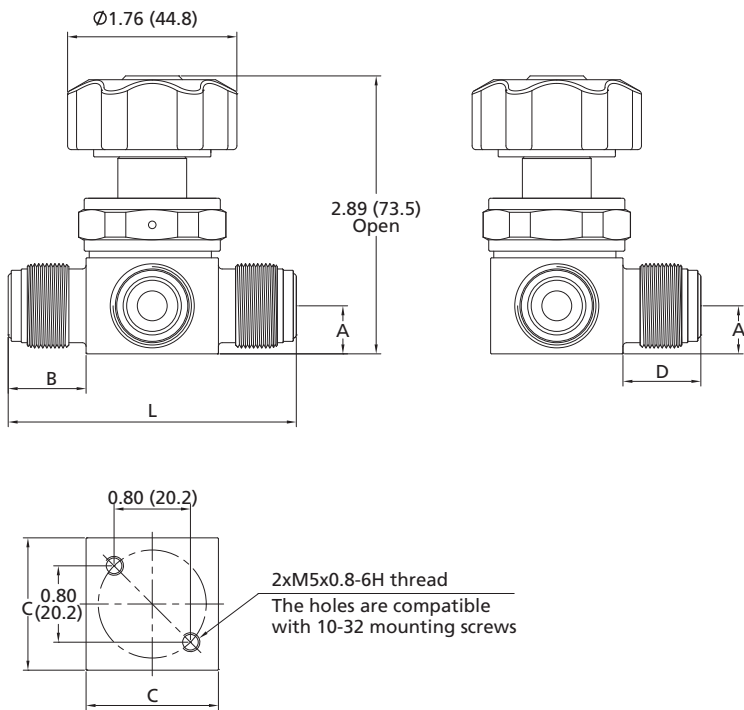

Pneumatic

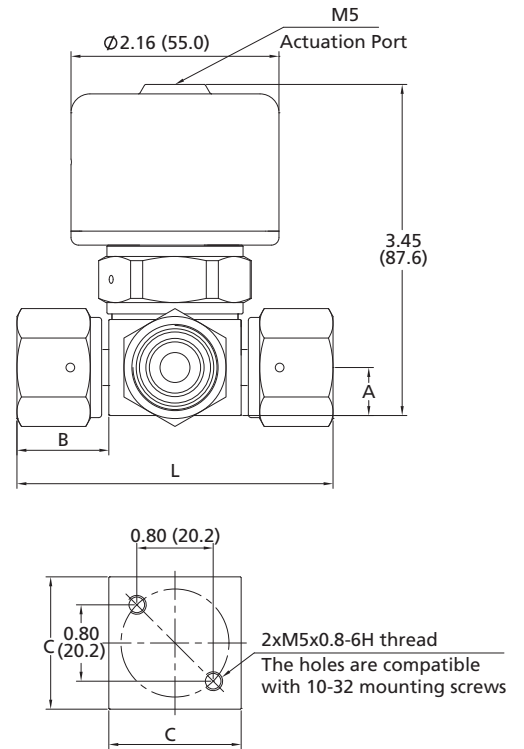

Basic Ordering Number	Connection Type and Size	Dimensions in. (mm)				
		A	B	C	D	L
DR□□-TB6-	3/8" Tube Butt Weld	0.50 (12.7)	0.67 (17.0)	1.38 (35.0)	0.67 (17.0)	2.72 (69.0)
DR□□-TB8-	1/2" Tube Butt Weld	0.50 (12.7)	0.67 (17.0)	1.38 (35.0)	0.67 (17.0)	2.72 (69.0)
DR□□-FFR8-	1/2" Female FR	0.50 (12.7)	0.94 (24.0)	1.38 (35.0)	0.94 (24.0)	3.27 (83.0)
DR□□-RFR8-	1/2" Rotatable Male FR	0.50 (12.7)	0.94 (24.0)	1.38 (35.0)	0.94 (24.0)	3.27 (83.0)
DR□□-FR8-	1/2" Integral Male FR	0.50 (12.7)	0.81 (20.6)	1.38 (35.0)	0.81 (20.6)	3.00 (76.2)

Flow Paths

☉ Flow paths as viewed from the top

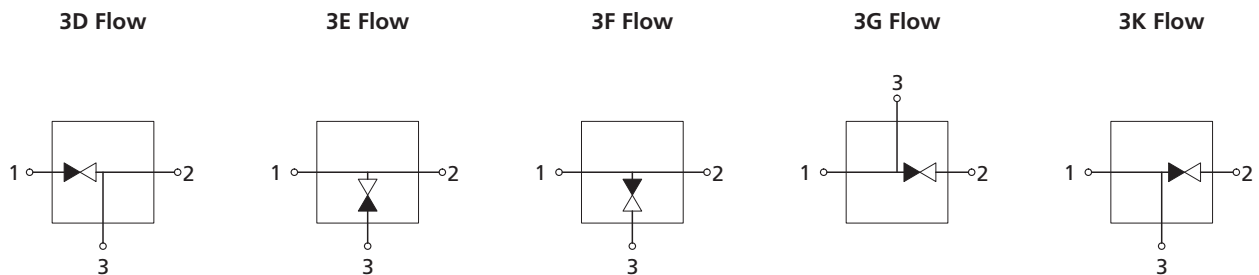

Ordering Number Description

DR6L - FFR8 - RFR8 - FR8 - 3D - RAF3M

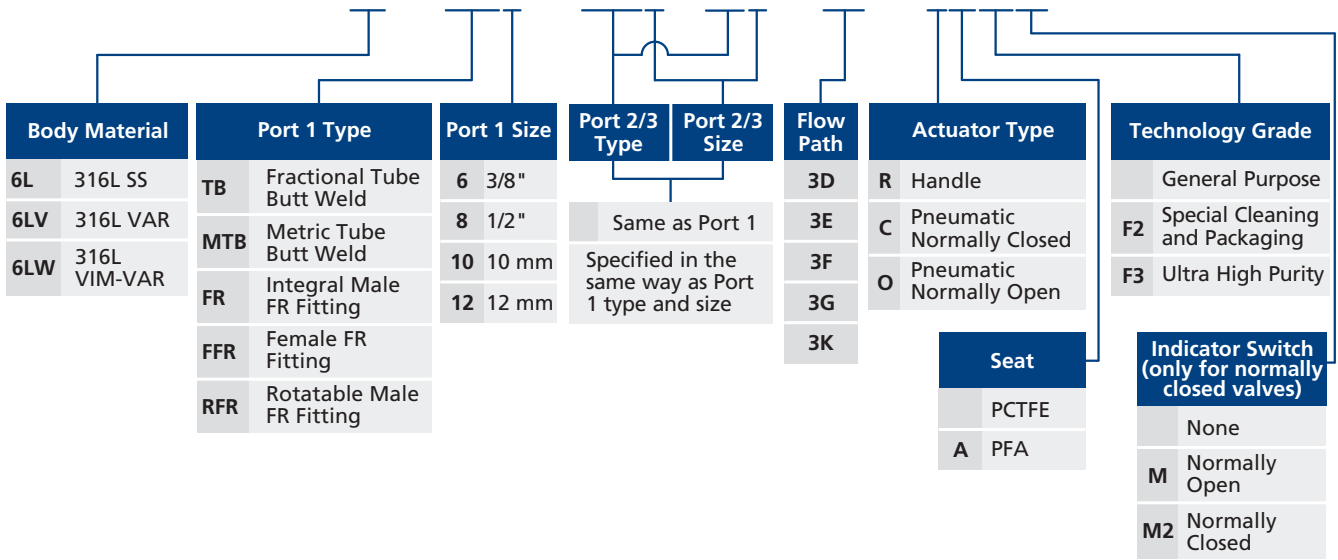

Fittings

Valves & Regulators

Diaphragm Valves

DV Series Low Pressure/High Flow Diaphragm Valves

Features

- ⦿ Ideal for high flow applications
- ⦿ Metal-to-metal seal
- ⦿ Tide-diaphragm design to provide positive stem retraction
- ⦿ No springs or threads in wetted areas to ensure clean operation

Technical Data

Port Size	1/2" to 1" or 12 mm to 18 mm	
Flow Coefficient (Cv)	2.8	
Orifice Size	0.5 in. (12.7 mm)	
Max. Working Pressure	300 psig (20.6 bar)	
Temperature	PCTFE: -10~150°F (-23~65°C) Vespel: -10~250°F (-23~121°C)	
Leak Rate (Helium)	Internal	≤1x10 ⁻⁹ mbar l/s
	External	≤1x10 ⁻⁹ mbar l/s

Flow Data

Air @ 70°F (21°C)
Water @ 60°F (16°C)

Pressure Drop to Atmosphere psi (bar)	Air (l/min)	Water (l/min)
10 (0.68)	870	34
50 (3.4)	2300	75
100 (6.8)	4100	100

Product Technology Grade

Product Grade Technology	General Purpose	Special Cleaning and Packaging (F2)	Ultra High Purity (F3)
Material/Specification	316 SS/ASTM A479 or 316L SS/ASTM A479		316L SS/ASTM A479
Wetted Surface Roughness	Ra 10 µin. (0.25 µm)		Ra 5 µin. (0.13 µm)
Polishing Process	Machine finished		Electropolished
Process Specification	FC-01 Standard Cleaning and Packaging	FC-02 Special Cleaning and Packaging	FC-03 Ultra High Purity Process Specification
Cleaning	Thrice degreasing ultrasonic cleaning	Special cleaning with non-ozone-depleting chemicals	Ultra high purity cleaning in continuously monitored ultrasonic cleaning system with deionized water
Assembly Environment	At atmosphere	In specially cleaned areas	In ISO Class 5/Federal Class 100 cleanroom
Packaging	Individually bagged	Double bagged	Double bagged and vacuum sealed in cleanroom

Major Materials of Construction

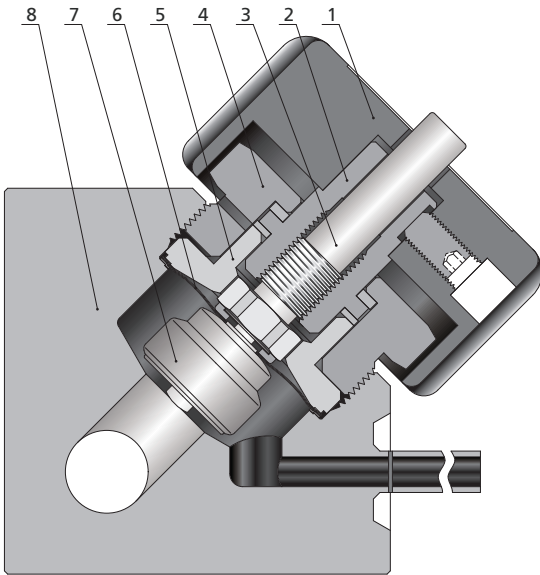

Item	Component	Material/Specification
1	Handle	Aluminum
2	Actuator	316 SS/ASTM A479
3	Upper Stem	316 SS/ASTM A479
4	Bonnet Nut	316 SS/ASTM A479
5	Bonnet	S17400/ASTM A564
6	Diaphragm (2)	Elgiloy/AMS 5876
7	Stem Subassembly	316L SS/ASTM A479 and PCTFE/ASTM D1430 or 316L SS/ASTM A479 and Vespel
8	Body	316 SS/ASTM A479 or 316L SS/ASTM A479

Actuators

Manual - Round Handle

© Upper stem position to indicate open and closed states

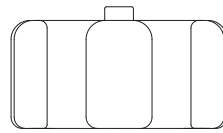

OPEN

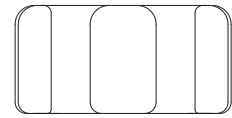

CLOSED

Notes: The upper stem protruding from the handle indicates open state.
The upper stem paralleling to or sinking into the handle indicates closed state.

Dimensions and Ordering Information

Straight Type

Dimensions

Dimensions, in inches (millimeters), are for reference only.

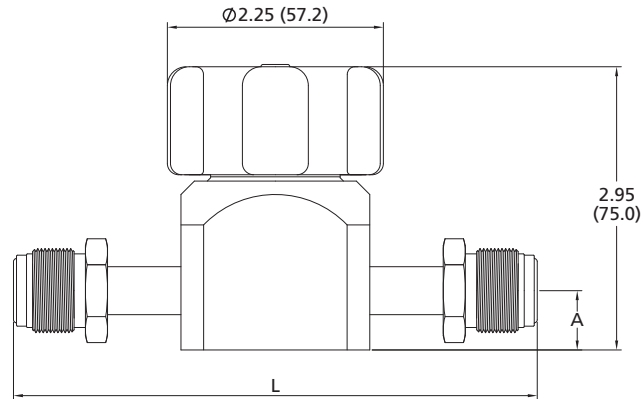

Basic Ordering Number	Connection Type and Size	Dimensions in. (mm)	
		A	L
DV□□-TB8-	1/2" Tube Butt Weld	0.62 (15.7)	5.91 (150.0)
DV□□-TB12-	3/4" Tube Butt Weld	0.62 (15.7)	5.91 (150.0)
DV□□-FR8-	1/2" Integral Male FR	0.62 (15.7)	5.46 (138.7)
DV□□-FFR8-	1/2" Female FR	0.62 (15.7)	5.46 (138.7)
DV□□-FL8-	1/2" FITOK Tube Fitting	0.62 (15.7)	3.71 (94.2)
DV□□-FL12-	3/4" FITOK Tube Fitting	0.62 (15.7)	3.72 (94.4)

Ordering Number Description

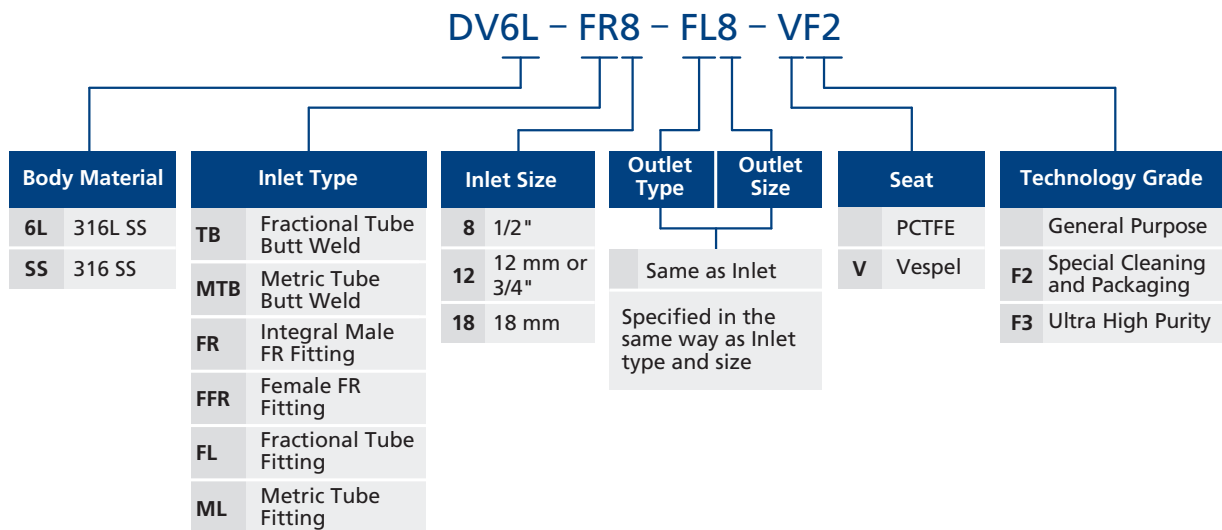

Branch Type

Dimensions

Dimensions, in inches (millimeters), are for reference only.

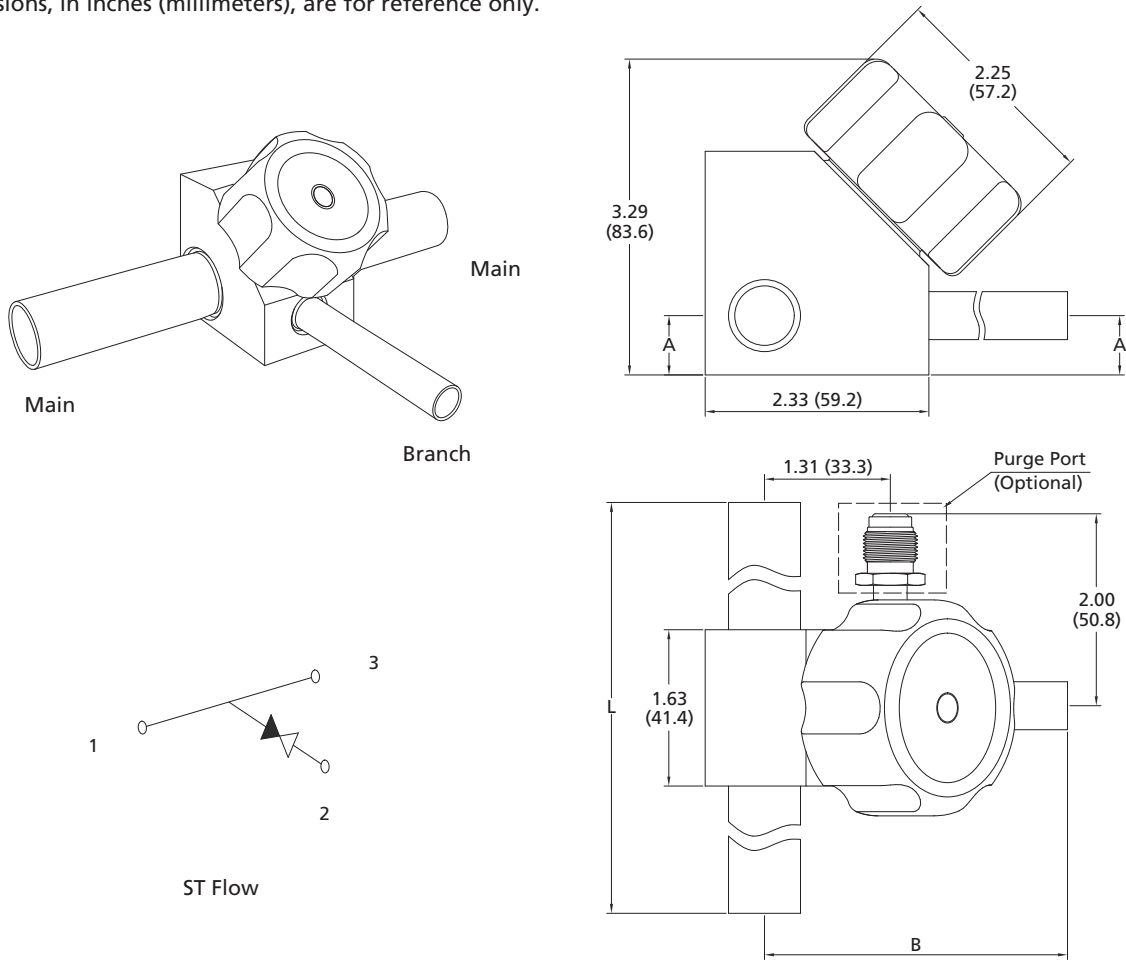

Basic Ordering Number	Connection Type and Size		Dimensions in. (mm)		
	Main	Branch	A	B	L
DV□□-TB8-TB4-	1/2" × 0.049"	1/4" × 0.035"	0.62 (15.7)	4.69 (119.0)	7.58 (193.0)
DV□□-TB8-TB8-	1/2" × 0.049"	1/2" × 0.049"	0.62 (15.7)	4.69 (119.0)	7.58 (193.0)
DV□□-TB8-RFR4-	1/2" × 0.049"	1/4" Rotatable Male FR	0.62 (15.7)	2.57 (65.0)	7.58 (193.0)
DV□□-TB8-RFR8-	1/2" × 0.049"	1/2" Rotatable Male FR	0.62 (15.7)	3.43 (87.0)	7.58 (193.0)
DV□□-TB12-TB8-	3/4" × 0.065"	1/2" × 0.049"	0.62 (15.7)	4.69 (119.0)	7.58 (193.0)
DV□□-TB12-RFR8-	3/4" × 0.065"	1/2" Rotatable Male FR	0.62 (15.7)	3.43 (87.0)	7.58 (193.0)
DV□□-TB16-TB8-	1" × 0.065"	1/2" × 0.049"	0.62 (15.7)	4.69 (119.0)	7.58 (193.0)
DV□□-TB16-RFR8-	1" × 0.065"	1/2" Rotatable Male FR	0.62 (15.7)	3.43 (87.0)	7.58 (193.0)

Block Type

Dimensions

Dimensions, in inches (millimeters), are for reference only.

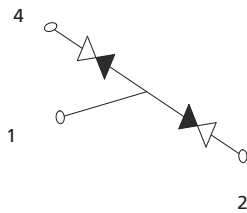
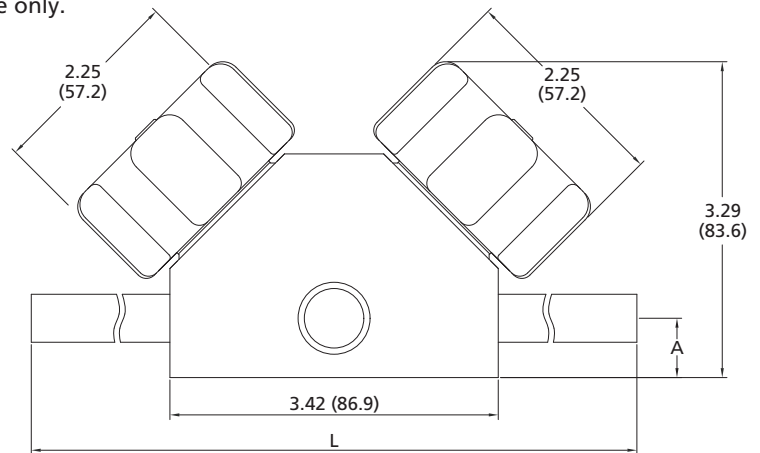
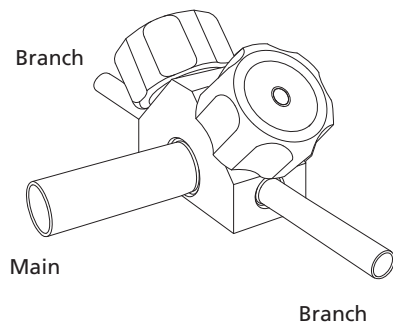

DT Flow

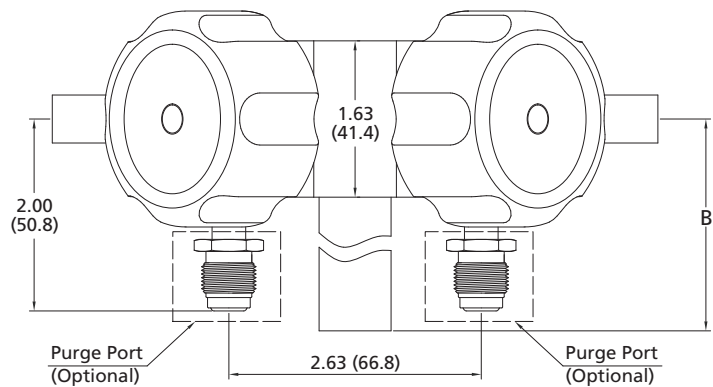

Basic Ordering Number	Connection Type and Size		Dimensions in. (mm)		
	Main	Branch	A	B	L
DV□□-TB12-TB8-	3/4" × 0.065"	1/2" × 0.049"	0.62 (15.7)	3.79 (96.3)	9.38 (238.0)
DV□□-TB12-RFR8-	3/4" × 0.065"	1/2" Rotatable Male FR	0.62 (15.7)	3.79 (96.3)	9.38 (238.0)
DV□□-TB16-TB8-	1" × 0.065"	1/2" × 0.049"	0.62 (15.7)	3.79 (96.3)	9.38 (238.0)
DV□□-TB16-RFR8-	1" × 0.065"	1/2" Rotatable Male FR	0.62 (15.7)	3.79 (96.3)	9.38 (238.0)

Block Type

Dimensions

Dimensions, in inches (millimeters), are for reference only.

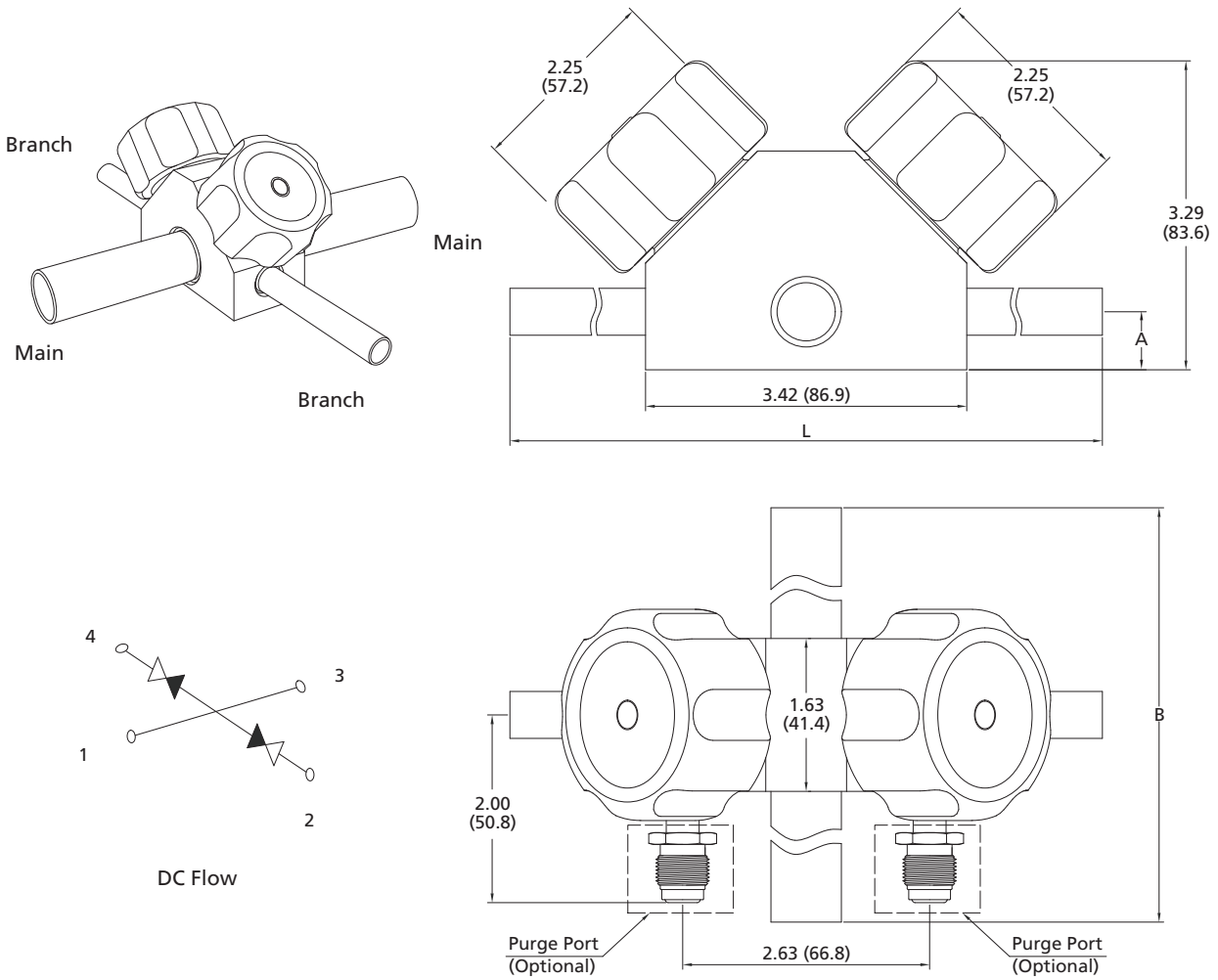

Basic Ordering Number	Connection Type and Size		Dimensions in. (mm)		
	Main	Branch	A	B	L
DV□□-TB8-TB8-	1/2" × 0.049"	1/2" × 0.049"	0.62 (15.7)	7.58 (193.0)	9.38 (238.0)
DV□□-TB8-RFR8-	1/2" × 0.049"	1/2" Rotatable Male FR	0.62 (15.7)	7.58 (193.0)	9.38 (238.0)
DV□□-TB12-TB8-	3/4" × 0.065"	1/2" × 0.049"	0.62 (15.7)	7.58 (193.0)	9.38 (238.0)
DV□□-TB12-RFR8-	3/4" × 0.065"	1/2" Rotatable Male FR	0.62 (15.7)	7.58 (193.0)	9.38 (238.0)
DV□□-TB16-TB8-	1" × 0.065"	1/2" × 0.049"	0.62 (15.7)	7.58 (193.0)	9.38 (238.0)
DV□□-TB16-RFR8-	1" × 0.065"	1/2" Rotatable Male FR	0.62 (15.7)	7.58 (193.0)	9.38 (238.0)

Ordering Number Description

Fittings

Valves & Regulators

DV6L - TB12 - TB8 - DC - P2 - VF2

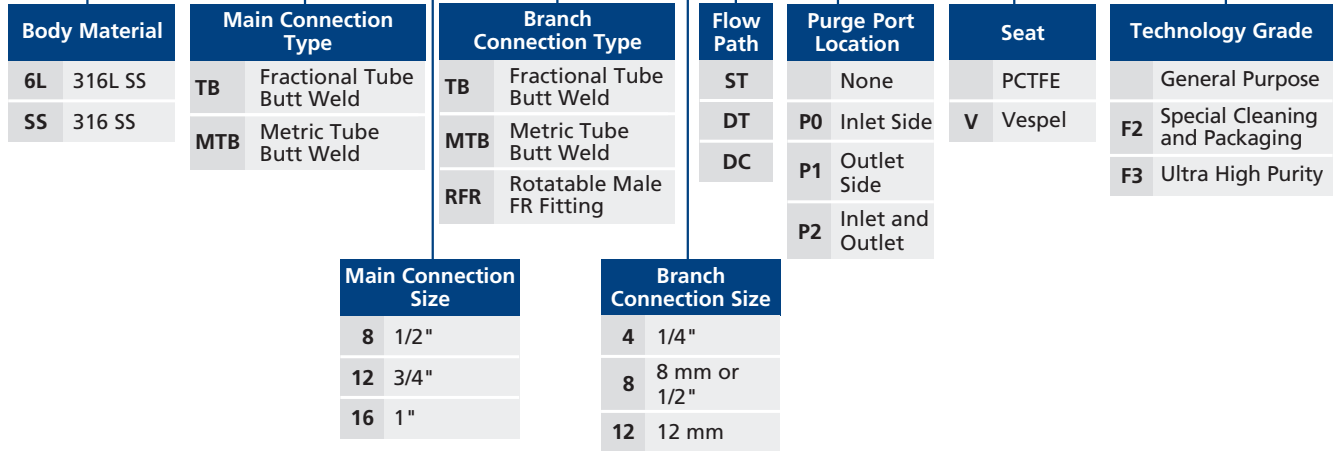

Diaphragm Valves

DL Series Low Pressure/Ultra High Flow Diaphragm Valves

Features

- ⦿ Ideal for ultra high flow applications
- ⦿ Metal to metal sealed diaphragm to ensure excellent leak integrity
- ⦿ Internally threadless and springless
- ⦿ PCTFE stem tip insert for leak-tight shutoff
- ⦿ Upper stem position to indicate open and closed states

Technical Data

Port Size	3/4" to 1" or 23 mm to 25 mm	
Flow Coefficient (Cv)	13	
Orifice Size	1.125 in. (28.6 mm)	
Max. Working Pressure	300 psig (20.6 bar)	
Temperature	PCTFE: -10~150°F (-23~65°C) Vespel: -10~250°F (-23~121°C)	
Leak Rate (Helium)	Internal	≤1x10 ⁻⁹ mbar l/s
	External	≤1x10 ⁻⁹ mbar l/s

Flow Data

Air @ 70°F (21°C)
Water @ 60°F (16°C)

Pressure Drop to Atmosphere psi (bar)	Air (l/min)	Water (l/min)
10(0.68)	3900	150
50(3.4)	11000	340
100(6.8)	19500	490

Product Technology Grade

Product Grade Technology	General Purpose	Special Cleaning and Packaging (F2)	Ultra High Purity (F3)
Material/Specification	CF8M/ASTM A351, CF3M/ASTM A351, 316 SS/ASTM A479		316L SS/ASTM A479
Wetted Surface Roughness	Ra 20 μin. (0.51 μm)		Ra 5 μin. (0.13 μm)
Polishing Process	Machine finished		Electropolished
Process Specification	FC-01 Standard Cleaning and Packaging	FC-02 Special Cleaning and Packaging	FC-03 Ultra High Purity Process Specification
Cleaning	Thrice degreasing ultrasonic cleaning	Special cleaning with non-ozone-depleting chemicals	Ultra high purity cleaning in continuously monitored ultrasonic cleaning system with deionized water
Assembly Environment	At atmosphere	In specially cleaned areas	In ISO Class 5/Federal Class 100 cleanroom
Packaging	Individually bagged	Double bagged	Double bagged and vacuum sealed in cleanroom

Major Materials of Construction

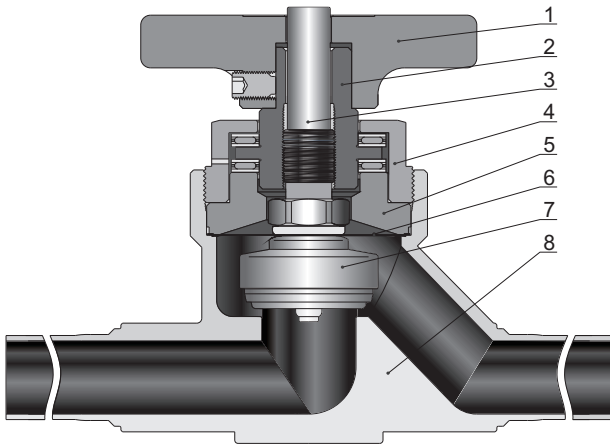

Item	Component	Material/Specification
1	Handle	Aluminum
2	Actuator	416 SS/ASTM A582
3	Upper stem	316 SS/ASTM A479
4	Bonnet nut	316 SS/ASTM A479
5	Bonnet	316 SS/ASTM A479
6	Diaphragm (3)	Elgiloy/AMS 5876
7	Stem subassembly	316L SS/ASTM A479 and PCTFE/ASTM D1430 or 316L SS/ASTM A479 and Vespel
8	Body	CF8M/ASTM A351, CF3M/ASTM A351 316 SS/ASTM A479 316L SS/ASTM A479

Actuators

Handle

- ⦿ Five turns and a half to operate from fully open to closed
- ⦿ Upper stem position to indicate open and closed states

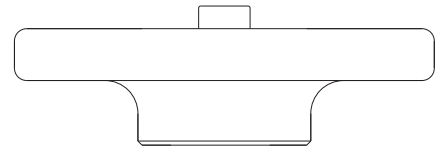

OPEN

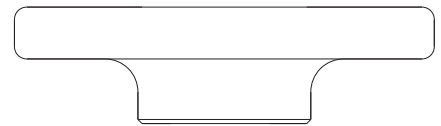

CLOSED

Notes: The upper stem protruding from the handle indicates open state.
The upper stem paralleling to or sinking into the handle indicates closed state.

Dimensions

Dimensions, in inches (millimeters), are for reference only.

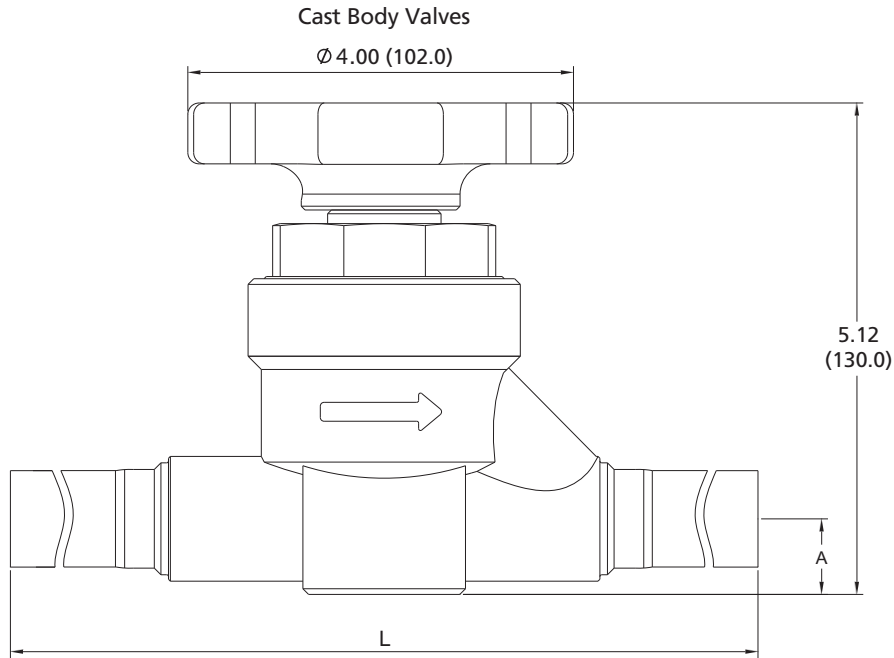

No purge ports

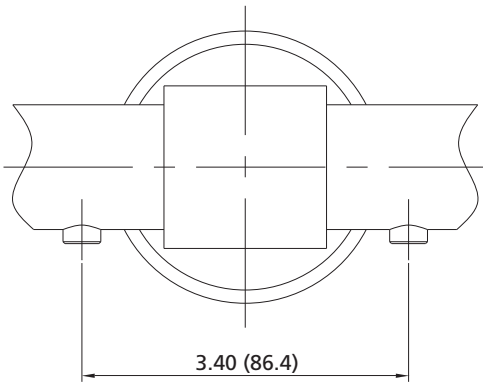

Integral 1/4" Male FR Fittings

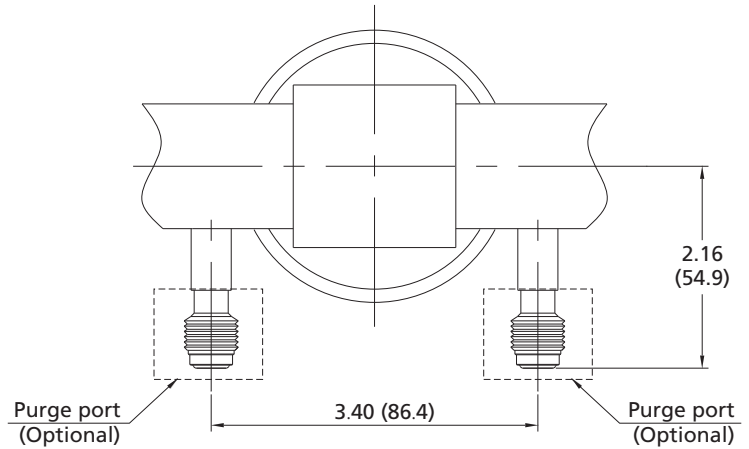

Basic Ordering Number	End Connections		Dimensions, in. (mm)	
	Type	Size	A	L
DL□□-FL12-	FITOK Tube Fitting	3/4"	0.79 (20.0)	8.27 (210.0)
DL□□-FL16-		1"		8.46 (215.0)
DL□□-ML25-		25 mm		8.63 (219.0)
DL□□-TB16-	Tube extension, 2.75 in. (69.8 mm) long	1" x 0.065"		10.90 (277.0)
DL□□-MTB23-		23 x 1.5 mm		
DL□□-MTB25-		25 x 1.5 mm		

Bar Stock Valves

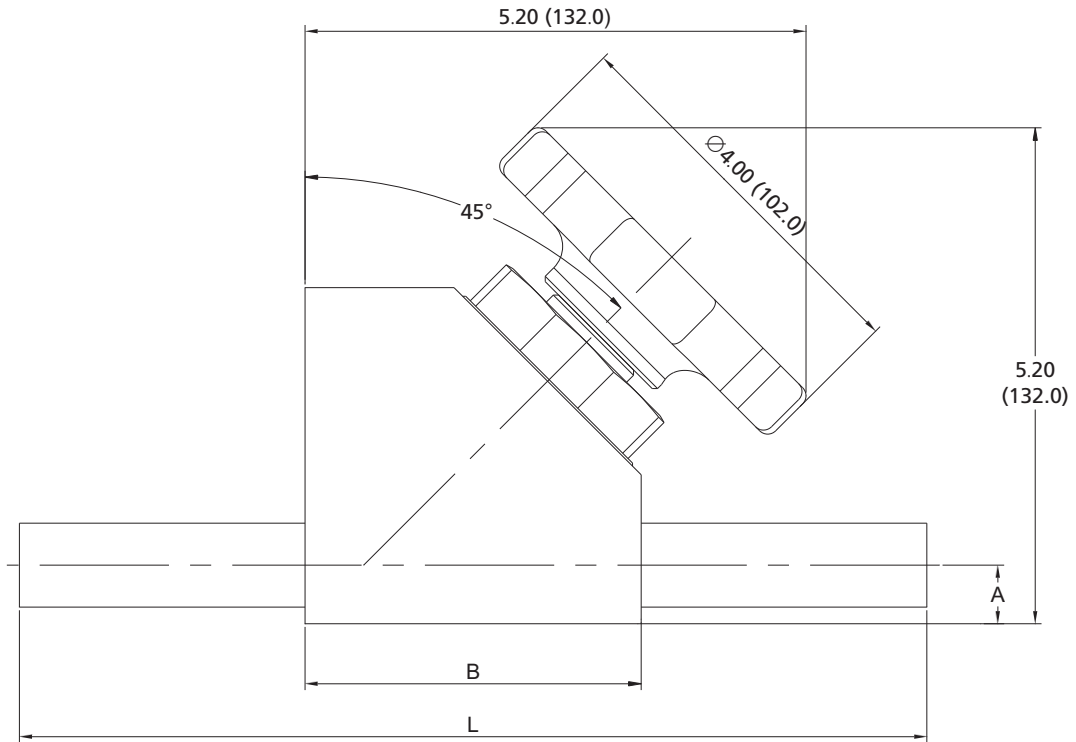

No purge ports

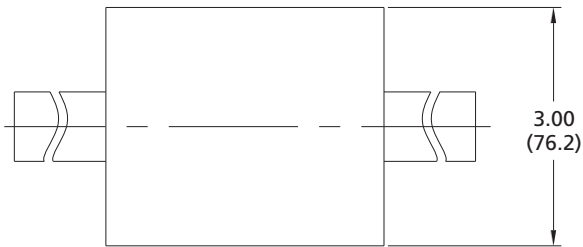

1/4" Rotatable Male FR Fittings

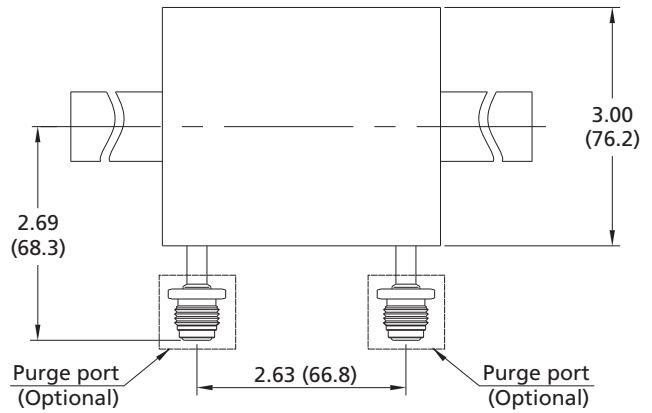

Basic Ordering Number	End Connections		Dimensions, in. (mm)		
	Type	Size	A	B	L
DL□□-TB12-B-	Tube Butt Weld	3/4" x 0.065"	0.61 (15.5)	3.50 (88.9)	9.46 (240.0)
DL□□-TB16-B-		1" x 0.065"			

Diaphragm Valves

DF Series High Pressure/High Flow Diaphragm Valves

Features

- Ideal for high flow applications
- Metal-to-metal seal
- Spring type design
- Elgiloy diaphragm to provide high strength and corrosion resistance to ensure long cycle life
- Indicator switch available assembled on pneumatic valves, transmitting a signal to an electrical device to indicated either the open or closed position of the valves
- Normally closed and normally open indicator switches optional

Technical Data

Port Size			3/8" to 1/2" or 8 mm to 12 mm
Flow Coefficient (Cv)			0.80
Orifice Size			0.31 in. (8.0 mm)
Max. Working Pressure	Handle	3500 psig (241 bar)	
	Pneumatic	3000 psig (206 bar)	
Max. Differential Back Pressure			150 psig (10.3 bar)
Pneumatic Actuator Operating Pressure			60 to 90 psig (4.2 to 6.2 bar)
Temperature			PCTFE: -10~150°F (-23~65°C) Vespel: -10~250°F (-23~121°C)
Leak Rate (Helium)	Internal	≤4x10 ⁻⁹ mbar l/s	
	External	≤4x10 ⁻⁹ mbar l/s	

Flow Data

Air @ 70°F (21°C)

Water @ 60°F (16°C)

Pressure Drop to Atmosphere psi (bar)	Air (l/min)	Water (l/min)
10 (0.68)	274	9.5
50 (3.4)	733	21.5
100 (6.8)	1300	30.3

Product Technology Grade

Product Grade Technology	General Purpose	Special Cleaning and Packaging (F2)	Ultra High Purity (F3)
Material/Specification	316 SS/ASTM A479 or 316L SS/ASTM A479		316L SS/ASTM A479
Wetted Surface Roughness	Ra 20 µin. (0.51 µm)		Ra 10 µin. (0.25 µm)
Polishing Process	Machine finished		Electropolished
Process Specification	FC-01 Standard Cleaning and Packaging	FC-02 Special Cleaning and Packaging	FC-03 Ultra High Purity Process Specification
Cleaning	Thrice degreasing ultrasonic cleaning	Special cleaning with non-ozone-depleting chemicals	Ultra high purity cleaning in continuously monitored ultrasonic cleaning system with deionized water
Assembly Environment	At atmosphere	In specially cleaned areas	In ISO Class 5/Federal Class 100 cleanroom
Packaging	Individually bagged	Double bagged	Double bagged and vacuum sealed in cleanroom

Major Materials of Construction

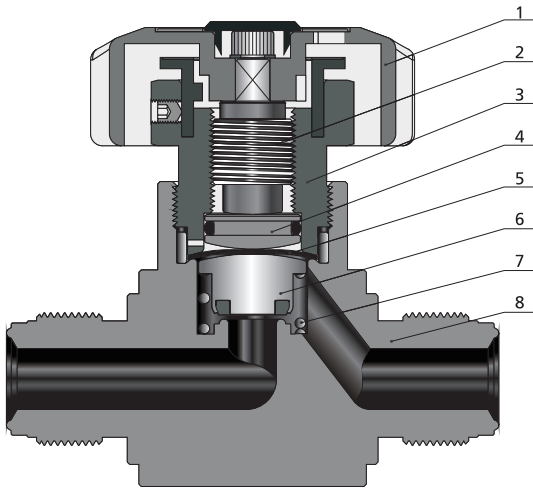

Round Handle Model

Item	Component	Material/Specification
1	Handle	Aluminum
2	Actuator	316 SS/ASTM A479
3	Bonnet Nut	S17400/ASTM A564
4	Button	C36000/ASTM B16
5	Diaphragm (5)	Elgiloy (3) /AMS 5876 + C17200 (2) /ASTM B194
6	Stem Subassembly	316L SS/ASTM A479 and PCTFE/ASTM D1430 or 316L SS/ASTM A479 and Vespel
7	Spring	316 SS/ASTM A313
8	Body	316 SS/ASTM A479 or 316L SS/ASTM A479

Actuators

Manual - Round Handle

- ⦿ One-half turn to operate from fully open to closed
- ⦿ Handle with window to visually indicate open and closed states



Pneumatic

- ⦿ Normally open, "N.O." marked on the top of the cylinder
- ⦿ Normally closed, "N.C." marked on the top of the cylinder



Dimensions

Dimensions, in inches (millimeters), are for reference only.

Manual - Round Handle

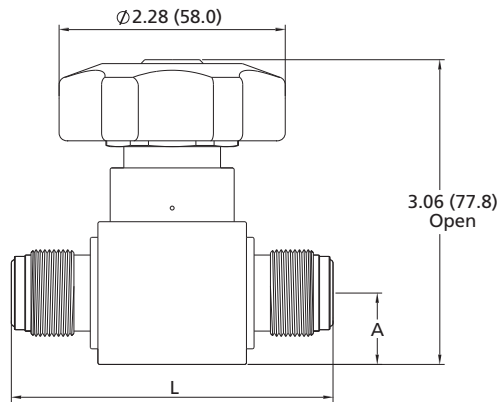

Pneumatic

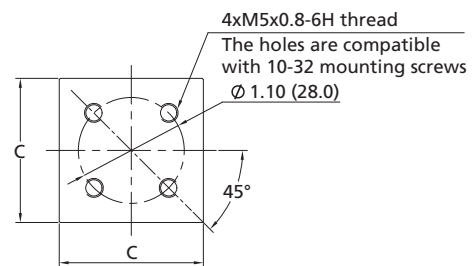
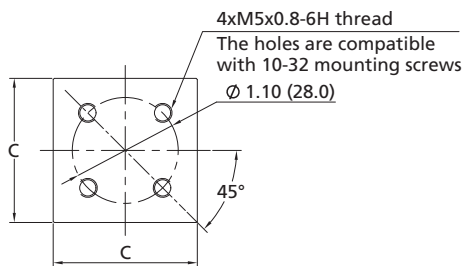
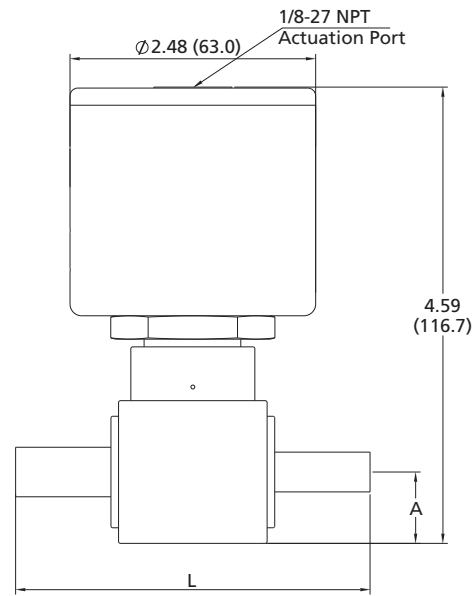

Basic Ordering Number	Connection Type and Size	Dimensions in. (mm)		
		A	C	L
DF□□-TB6-	3/8" Tube Butt Weld	0.71 (18.0)	1.50 (38.1)	3.58 (90.9)
DF□□-TB8-	1/2" Tube Butt Weld	0.71 (18.0)	1.50 (38.1)	3.58 (90.9)
DF□□-FR8-	1/2" Integral Male FR	0.71 (18.0)	1.50 (38.1)	3.25 (82.5)
DF□□-FFR8-	1/2" Female FR	0.71 (18.0)	1.50 (38.1)	3.89 (98.8)
DF□□-FL6-	3/8" FITOK Tube Fitting	0.71 (18.0)	1.50 (38.1)	3.27 (83.0)
DF□□-FL8-	1/2" FITOK Tube Fitting	0.71 (18.0)	1.50 (38.1)	3.47 (88.2)
DF□□-FNS8-	1/2" Female NPT	0.71 (18.0)	1.50 (38.1)	3.30 (84.0)

Ordering Number Description

DFSS - FR8 - FL8 - CVF2M

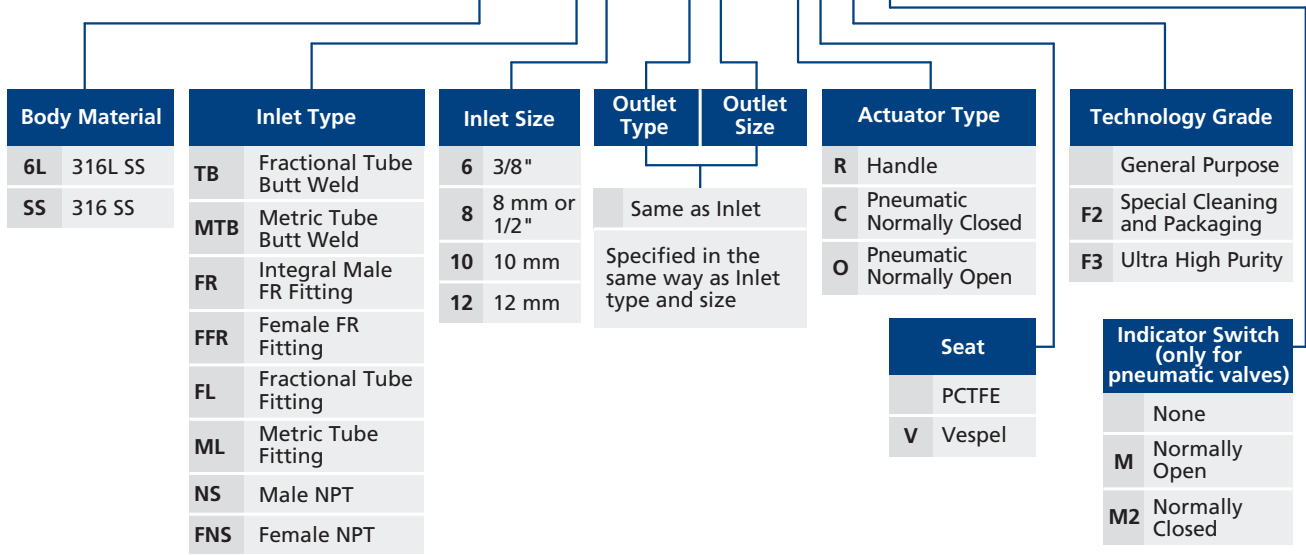

Fittings

Valves & Regulators

Bellows-sealed Valves

SM, SVH Series

Fittings

Valves & Regulators



Bellows-sealed Valves

SM Series Low Pressure Bellows-sealed Valves

Features

- ⦿ Metal-to-metal gasket seal without external leakage
- ⦿ Precision-formed metal bellows to ensure reliability
- ⦿ Non-rotating stem tip to increase shutoff cycle life
- ⦿ Handle and pneumatic actuator available
- ⦿ Pneumatic actuator to rotate 360° for ease of installation
- ⦿ Panel mounting and bottom mounting available
- ⦿ Indicator switch available assembled on normally closed valves, transmitting a signal to an electrical device to indicated either the open or closed position of the valves

Technical Data

Type		SM4	SM8
Ports Size		1/4" to 3/8" or 6 mm to 8 mm	3/8" to 1/2" or 10 mm to 12 mm
Flow Coefficient (Cv)		0.30	0.80
Orifice Size		0.16 in. (4.1mm)	0.31 in. (8.0 mm)
Max Working Pressure	Handle	500 psig (34.4 bar)	
	Pneumatic	145 psig (10 bar)	
Pneumatic Actuator Operating Pressure		60 to 90 psig (4.2 to 6.2 bar)	
Temperature		PCTFE: 10 ~ 200°F (-23 ~ 93°C) PFA: -10 ~ 302°F (-23 ~ 150°C) Vespel: 10 ~ 400°F (-23 ~ 204°C)	
Leak rate (Helium)	Internal	≤ 4x10 ⁻⁹ mbar l/s	
	External	≤ 4x10 ⁻⁹ mbar l/s	

Flow Data

Air @ 70°F (21°C)

Water @ 60°F (16°C)

Pressure Drop to Atmosphere psi (bar)	Sm4: Cv 0.30		Sm8: Cv 0.80	
	Air (l/min)	Water (l/min)	Air (l/min)	Water (l/min)
10 (0.68)	96	3.6	270	9.6
50 (3.4)	250	7.9	730	21.6
100 (6.8)	450	11.0	1280	30.0

Product Technology Grade

Product Grade Technology	General Purpose	Special Cleaning and Packaging (F2)	Ultra High Purity (F3)
Material/Specification	316 SS/ASTM A479 316L SS/ASTM A479		316L VAR/SEMI F20
Wetted Surface Roughness	Ra 20 µin. (0.51 µm)		Ra 8 µin. (0.20 µm)
Polishing Process	Machine finished		Electropolished
Process Specification	FC-01 Standard Cleaning and Packaging	FC-02 Special Cleaning and Packaging	FC-03 Ultra High Purity Process Specification
Cleaning	Thrice degreasing ultrasonic cleaning	Special cleaning with non-ozone-depleting chemicals	Ultra high purity cleaning in continuously monitored ultrasonic cleaning system with deionized water
Assembly Environment	At atmosphere	In specially cleaned areas	In ISO Class 5/Federal Class 100 cleanroom
Packaging	Individually bagged	Double bagged	Double bagged and vacuum sealed in cleanroom

Major Materials of Construction

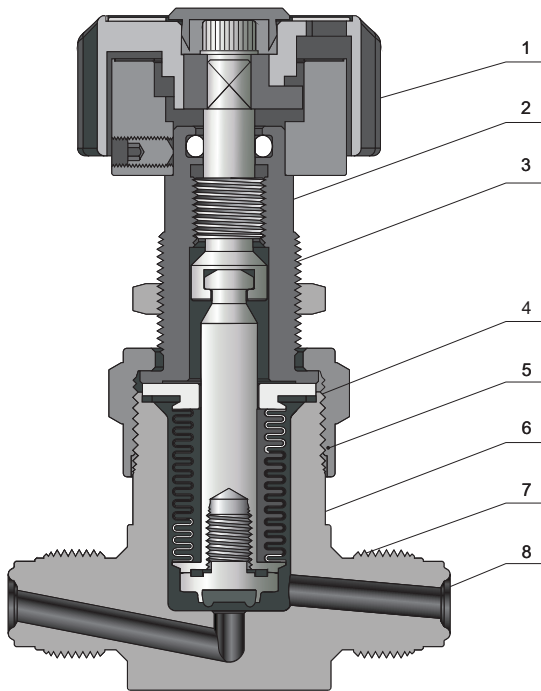

Round Handle Model

Item	Component	Material/Specification
1	Handle	ABS
2	Actuator	416 SS/ASTM A582
3	Bonnet	316 SS/ASTM A479
4	Bonnet Gasket	316L SS/ASTM A269
5	Bonnet nut	316 SS/ASTM A479
6	Bellows	316L SS/ASTM A269
7	Seat	PCTFE/ASTM D1430 or PFA/ASTM D3307
8	Body	316 SS/ASTM A479 or 316L SS/ASTM A479

Actuators

Manual - Round Handle

- ⦿ Half turn to operate from fully open to closed
- ⦿ Handle with window to visually indicate open and closed states



Pneumatic

- ⦿ Normally open, "N.O." marked on the top of the cylinder
- ⦿ Normally closed, "N.C." marked on the top of the cylinder



Dimensions and Ordering Information

Straight Type

Dimensions

Dimensions, in inches (millimeters), are for reference only.

Manual - Handle

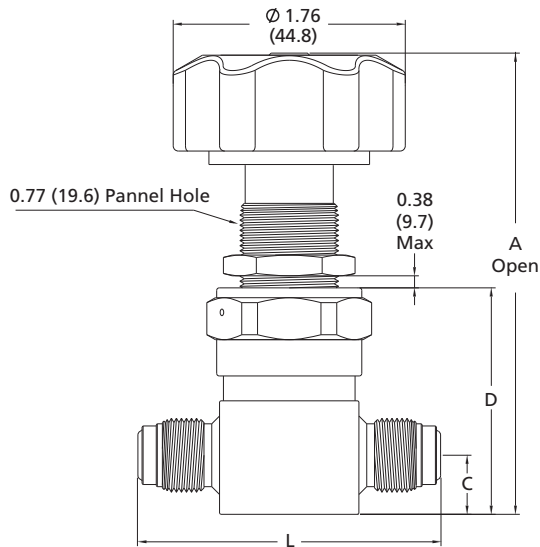

Pneumatic

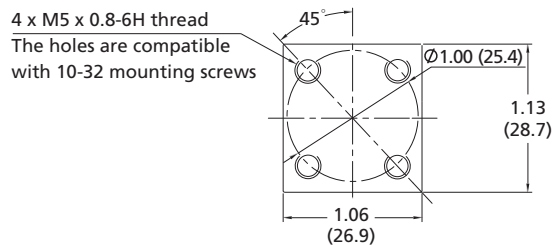
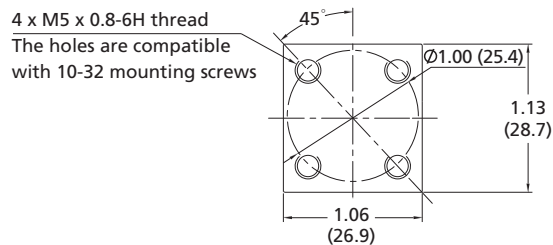
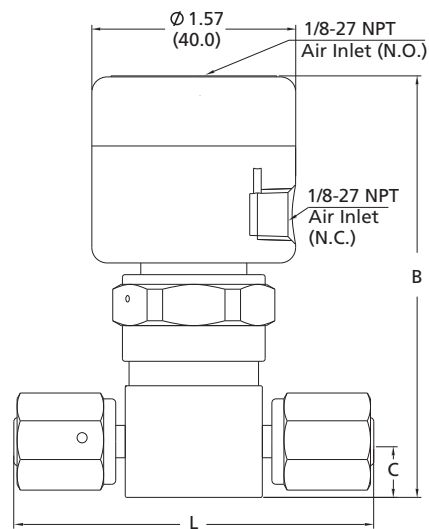

Basic Ordering Number	Connection Type and Size	Dimensions, in. (mm)				
		A	B	C	D	L
SM4 Series						
SM4□□-FL4-	1/4" FITOK Tube Fitting	3.51 (89.4)	3.31 (84.0)	0.45 (11.4)	1.78 (45.2)	2.46(62.5)
SM4□□-FL6-	3/8" FITOK Tube Fitting					2.58(65.5)
SM4□□-ML6-	6 mm FITOK Tube Fitting					2.46(62.5)
SM4□□-ML8-	8 mm FITOK Tube Fitting					2.53(64.3)
SM4□□-TB4-	1/4" Tube Butt Weld					1.74(44.2)
SM4□□-TB6-	3/8" Tube Butt Weld					
SM4□□-MTB6-	6 mm Tube Butt Weld					
SM4□□-TS4-	1/4" Tube Socket Weld					
SM4□□-FR4-	1/4" Integral Male FR					
SM4□□-FFR4-	1/4" Female FR					
SM4□□-FO4-	1/4" Male FO					
SM8 Series						
SM8□□-FL6-	3/8" FITOK Tube Fitting	3.77 (95.7)	3.76 (95.5)	0.53 (13.5)	2.02 (51.3)	2.58(65.5)
SM8□□-FL8-	1/2" FITOK Tube Fitting					2.80(71.1)
SM8□□-ML10-	10 mm FITOK Tube Fitting					2.60(66.0)
SM8□□-ML12-	12 mm FITOK Tube Fitting					2.80(71.1)
SM8□□-TB6-	3/8" Tube Butt Weld					1.74(44.2)
SM8□□-TB8-	1/2" Tube Butt Weld					
SM8□□-FR8-	1/2" Integral Male FR	3.87 (98.2)	3.86 (98.0)	0.63 (16.0)	2.12 (53.8)	2.58(65.5)
SM8□□-FFR8-	1/2" Female FR					3.15(80.0)

Ordering Number Description

SM4SS - FL4 - ML6 - RAF2M

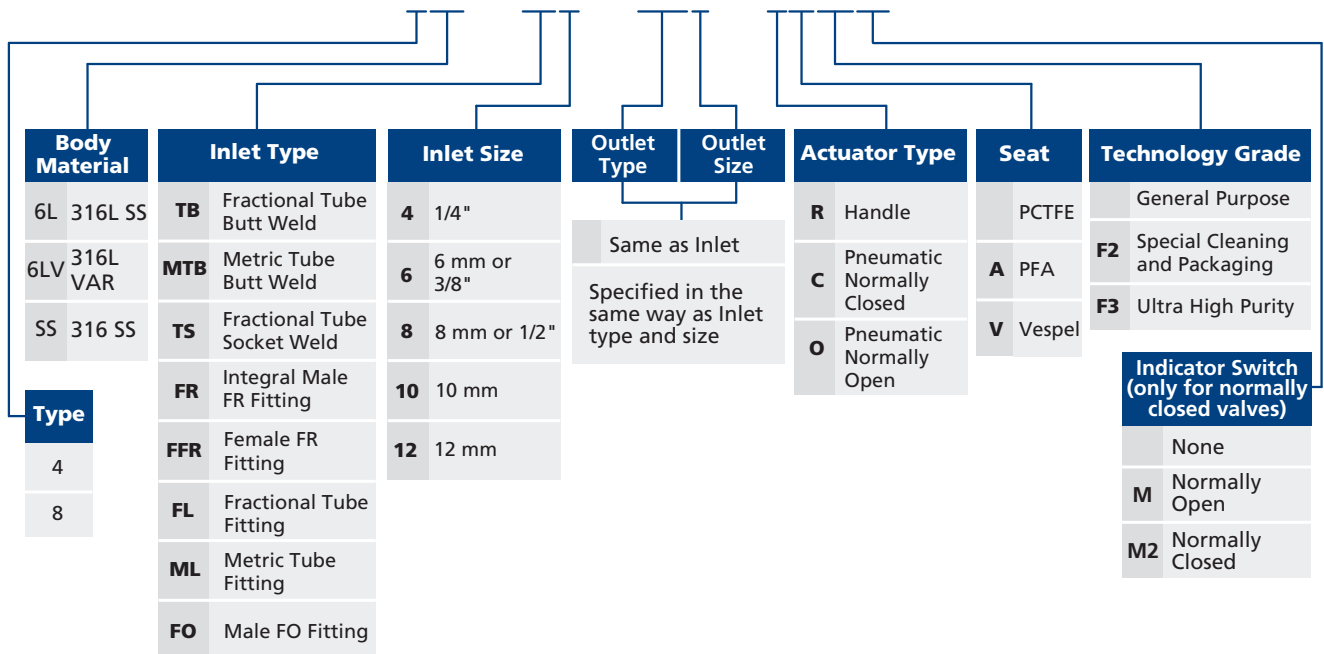

Branch Type

Dimensions

Dimensions, in inches (millimeters), are for reference only.

Manual - Handle

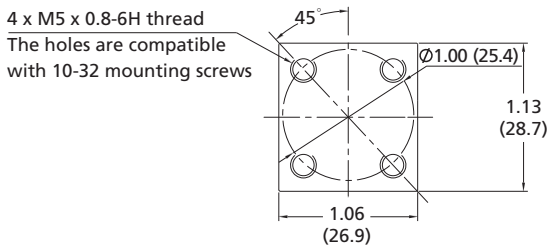
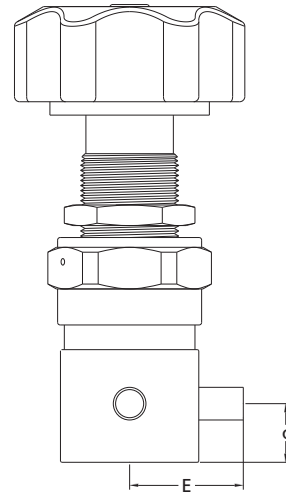
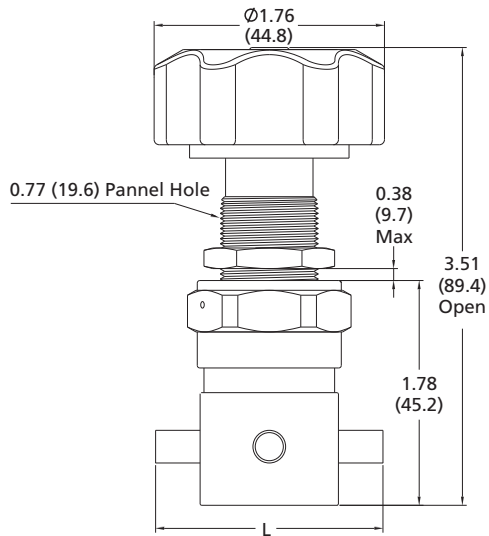

Pneumatic

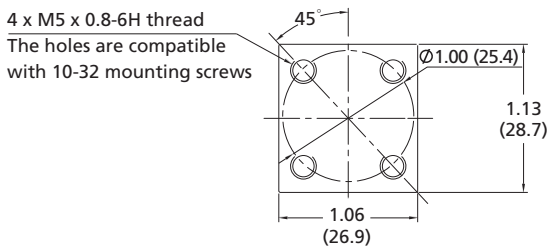
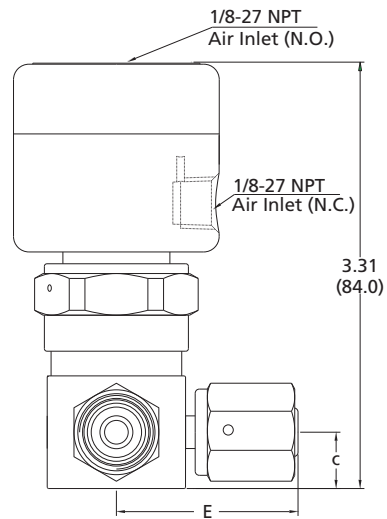
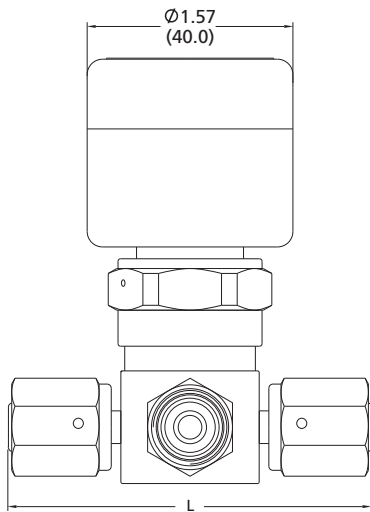

Basic Ordering Number	Connection Type and Size	Dimensions, in. (mm)		
		C	E	L
SM4□□-TB4-	1/4" Tube Butt Weld	0.45 (11.4)	0.87 (22.1)	1.74 (44.2)
SM4□□-MTB6-	6 mm Tube Butt Weld			
SM4□□-FFR4-	1/4" Female FR		1.38 (35.1)	2.76 (70.1)
SM4□□-RFR4-	1/4" Rotatable Male FR		1.74 (44.2)	3.48 (88.4)

Flow Paths

☉ Flow paths as viewed from the top

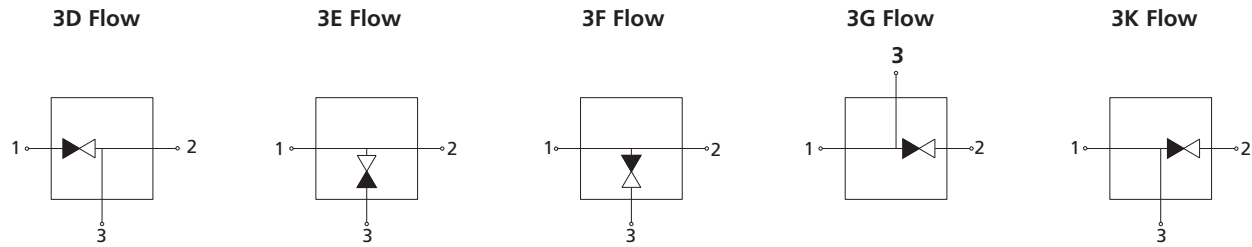

Ordering Number Description

SM4SS - TB4 - FR4 - FFR4 - 3G - RAF2M

Type	Body Material	Port 1 Type	Port 1 Size	Port 2/3 Type	Port 2/3 Size	Actuator Type	Seat	Indicator Switch (only for normally closed valves)
4	6L 316L SS	TB Fractional Tube Butt Weld	4 1/4"	Same as Port 1	Specified in the same way as Port 1 type and size	R Handle	PCTFE	None
6LV	316L VAR	MTB Metric Tube Butt Weld	6 6 mm or 3/8"			C Pneumatic Normally Closed	A PFA	M Normally Open
SS	316 SS	TS Fractional Tube Socket Weld	8 8 mm	O Pneumatic Normally Open	V Vespel	M2 Normally Closed		
		FR Integral Male FR Fitting						
		FFR Female FR Fitting						
		FL Fractional Tube Fitting						
		ML Metric Tube Fitting						
		FO Male FO Fitting						
						Flow Path	Technology Grade	
						3D	General Purpose	
						3E	F2 Special Cleaning and Packaging	
						3F	F3 Ultra High Purity	
						3G		
						3K		

Bellows-sealed Valves

SVH Series High Pressure Bellows-sealed Valves

Features

- ⦿ Packless valves with all-metal seal to atmosphere
- ⦿ Compact designed body with minimal dead space
- ⦿ 316L SS precision-formed bellows for long cycle life
- ⦿ PCTFE stem tip material with remarkable chemical and thermal resistance
- ⦿ Normally closed and normally open pneumatic actuator optional
- ⦿ Bottom mounting
- ⦿ Indicator switch available assembled on pneumatic valves, transmitting a signal to an electrical device to indicated either the open or closed position of the valves
- ⦿ Normally open and normally closed indicator switches optional

Technical Data

Ports Size	1/4" to 3/8" or 6 mm to 8 mm	
Flow Coefficient (Cv)	0.30	
Orifice Size	0.15 in. (3.8 mm)	
Max. Working Pressure	3500 psig (241 bar)	
Pneumatic Actuator Operating Pressure	60 to 90 psig (4.2 to 6.2 bar)	
Temperature	PCTFE: -40~150°F (-40~65°C) Vespel: -40~400°F (-40~204°C)	
Leak Rate (Helium)	Internal	≤4x10 ⁻⁹ mbar l/s
	External	≤4x10 ⁻⁹ mbar l/s

Flow Data

Air @ 70°F (21°C)
Water @ 60°F (16°C)

Pressure Drop to Atmosphere psi (bar)	Air (l/min)	Water (l/min)
10 (0.68)	96	3.6
50 (3.4)	250	7.9
100 (6.8)	450	11.0

Product Technology Grade

Product Grade Technology	General Purpose	Special Cleaning and Packaging (F2)	Ultra High Purity (F3)
Material/Specification	316 SS/ASTM A479 316L SS/ASTM A479		316L SS/ASTM A479
Wetted Surface Roughness	Ra 20 μin. (0.51 μm)		Ra 10 μin. (0.25 μm)
Polishing Process	Machine finished		Electropolished
Process Specification	FC-01 Standard Cleaning and Packaging	FC-02 Special Cleaning and Packaging	FC-03 Ultra High Purity Process Specification
Cleaning	Thrice degreasing ultrasonic cleaning	Special cleaning with non-ozone-depleting chemicals	Ultra high purity cleaning in continuously monitored ultrasonic cleaning system with deionized water
Assembly Environment	At atmosphere	In specially cleaned areas	In ISO Class 5/Federal Class 100 cleanroom
Packaging	Individually bagged	Double bagged	Double bagged and vacuum sealed in cleanroom

Major Materials of Construction

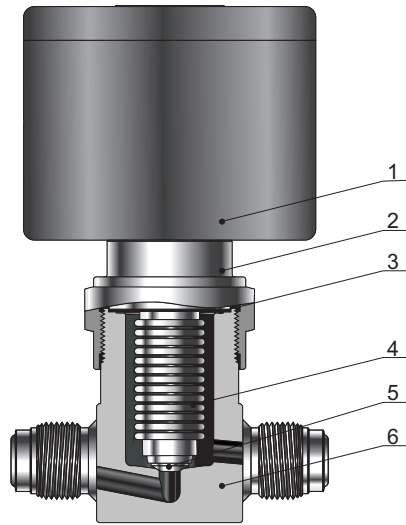

Normally Closed Model

Item	Component	Material/Specification
1	Pneumatic Actuator	Aluminum
2	Bonnet Nut	304 SS/ASTM A479
3	Gasket	PTFE-coated 316L SS/A240
4	Bellows	316L SS/ASTM A269
5	Seat	PCTFE/ASTM D1430 or Vsepel
6	Body	316 SS/ASTM A479 or 316L SS/ASTM A479

Pneumatic Actuators

- ⊙ Normally open, "N.O." marked on the top of the cylinder
- ⊙ Normally closed, "N.C." marked on the top of the cylinder



Dimensions and Ordering Information

Straight Type

Dimensions

Dimensions, in inches (millimeters), are for reference only.

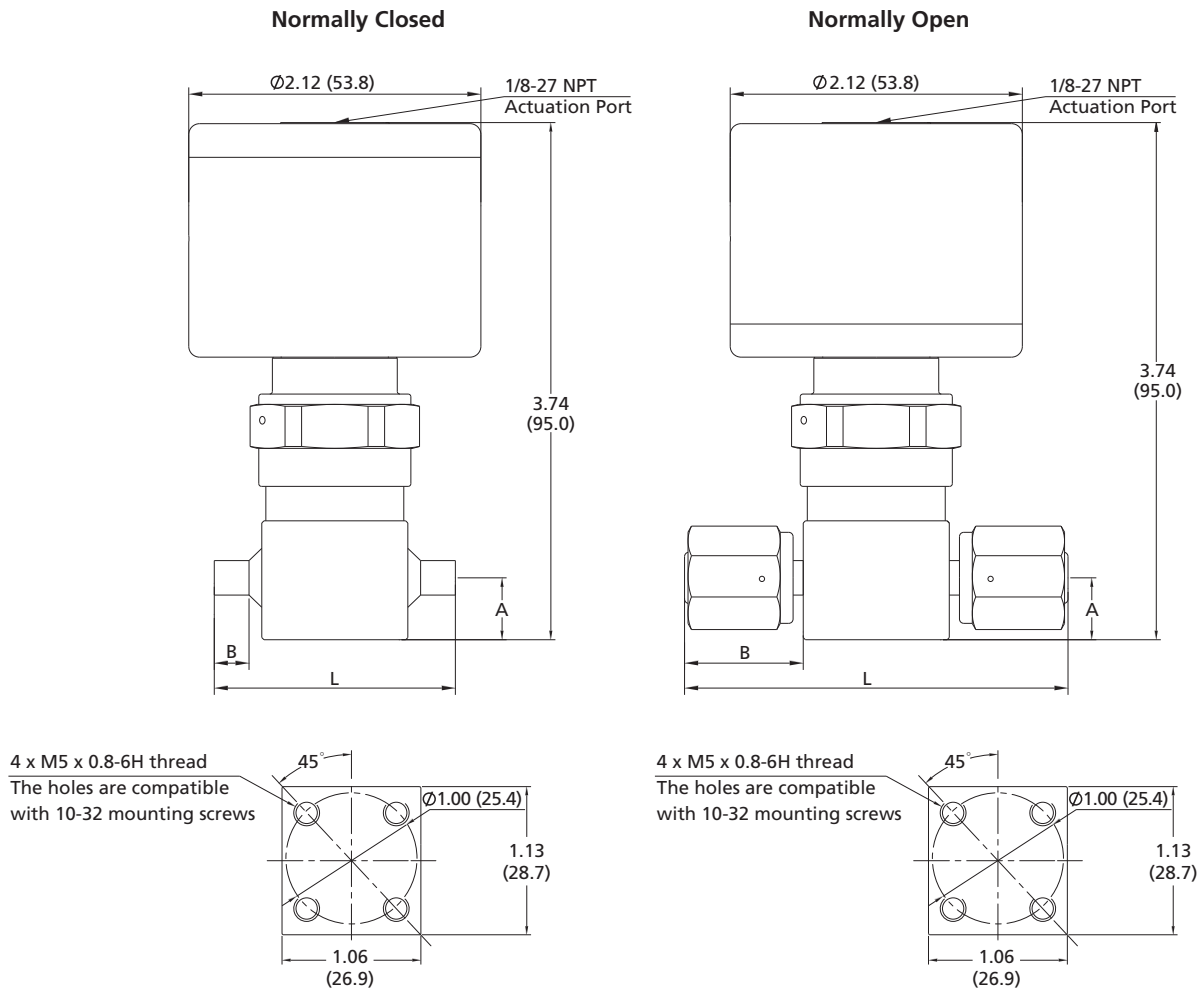

Basic Ordering Number	Connection Type and Size	Dimensions in. (mm)		
		A	B	L
SVH□□-TB4-	1/4" Tube Butt Weld	0.44 (11.2)	0.25 (6.4)	1.75 (44.4)
SVH□□-FFR4-	1/4" Female FR	0.44 (11.2)	0.85 (21.6)	2.76 (70.1)
SVH□□-FR4-	1/4" Integral Male FR	0.44 (11.2)	0.62 (15.7)	2.30 (58.4)
SVH□□-FL4-	1/4" FITOK Tube Fitting	0.44 (11.2)	0.70 (17.8)	2.46 (62.5)
SVH□□-FL6-	3/8" FITOK Tube Fitting	0.44 (11.2)	0.76 (19.3)	2.58 (65.5)
SVH□□-ML6-	6 mm FITOK Tube Fitting	0.44 (11.2)	0.70 (17.8)	2.46 (62.5)

Ordering Number Description

SVHSS – FL4 – ML6 – CVF2M

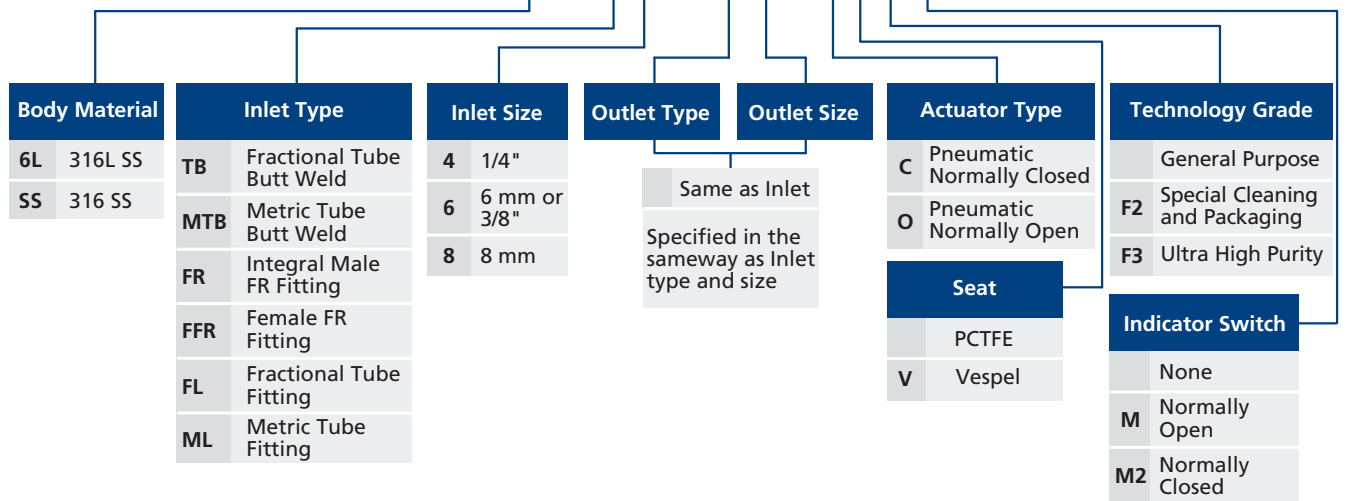

Fittings

Valves & Regulators

Branch Type

Dimensions

Dimensions, in inches (millimeters), are for reference only.

Normally Closed

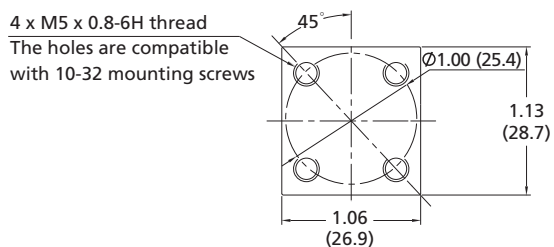
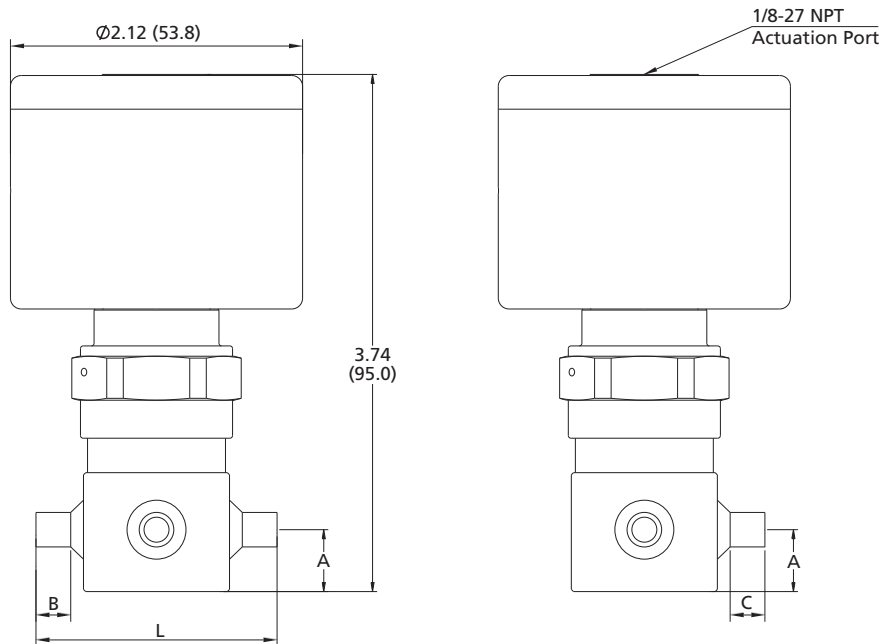

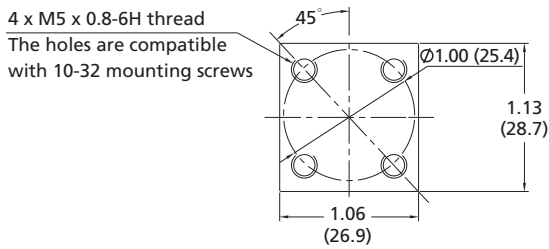
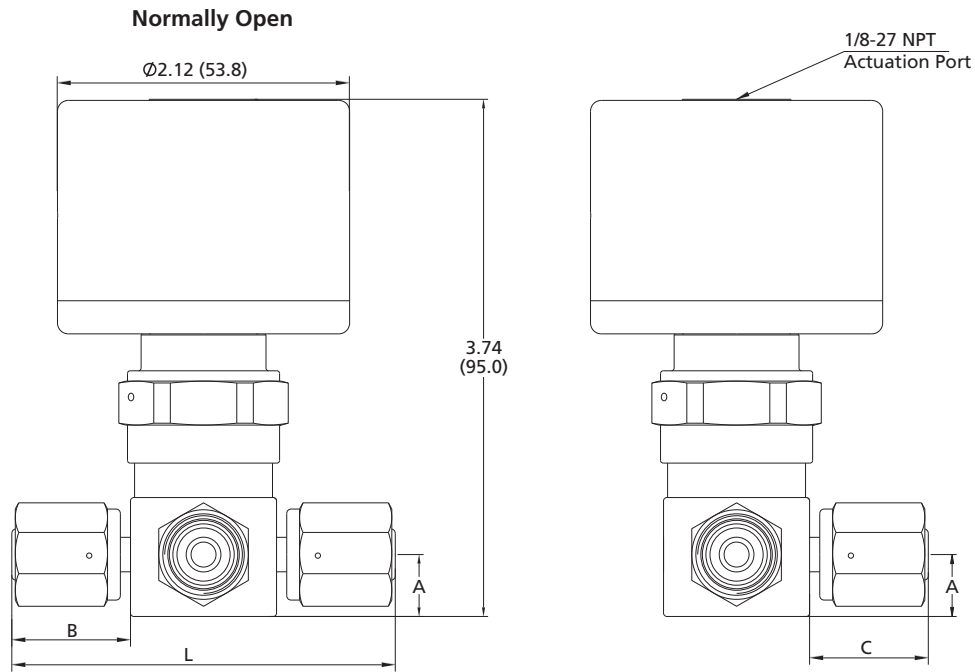

Basic Ordering Number	Connection Type and Size	Dimensions in. (mm)			
		A	B	C	L
SVH□□-TB4-	1/4" Tube Butt Weld	0.44 (11.2)	0.25 (6.4)	0.25 (6.4)	1.75 (44.4)
SVH□□-FFR4-	1/4" Female FR	0.44 (11.2)	0.85 (21.6)	0.85 (21.6)	2.76 (70.1)
SVH□□-FR4-	1/4" Integral Male FR	0.44 (11.2)	0.62 (15.7)	0.62 (15.7)	2.30 (58.4)
SVH□□-FL4-	1/4" FITOK Tube Fitting	0.44 (11.2)	0.70 (17.8)	0.70 (17.8)	2.46 (62.5)
SVH□□-FL6-	3/8" FITOK Tube Fitting	0.44 (11.2)	0.76 (19.3)	0.76 (19.3)	2.58 (65.5)
SVH□□-ML6-	6 mm FITOK Tube Fitting	0.44 (11.2)	0.70 (17.8)	0.70 (17.8)	2.46 (62.5)

Flow Paths

☉ Flow paths as viewed from the top

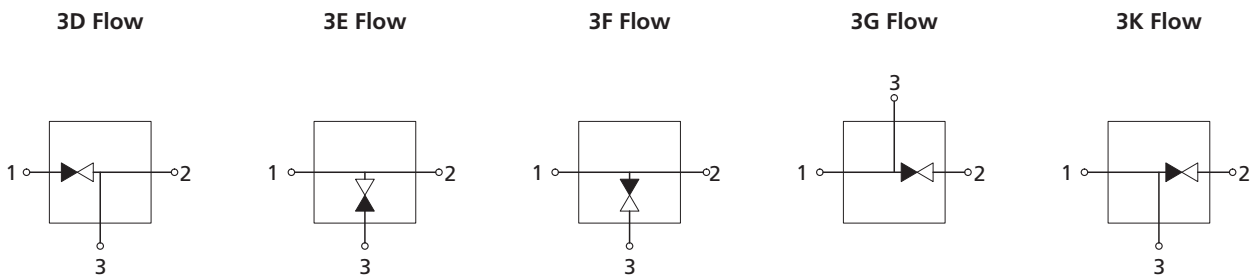

Ordering Number Description

SVHSS – TB4 – FR4 – FFR4 – 3G – CVF2M

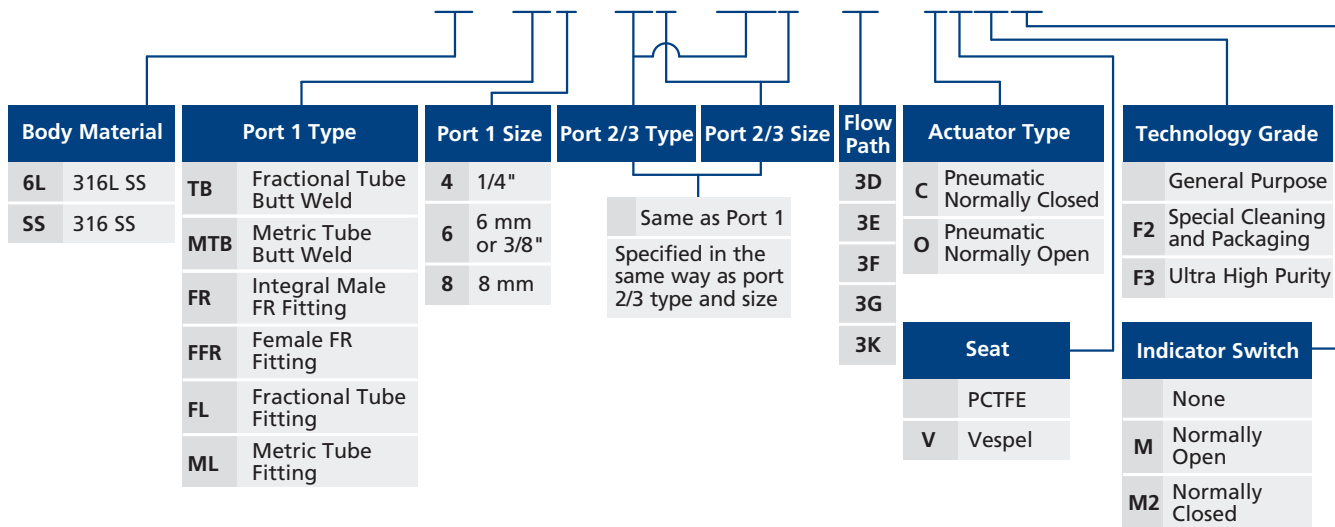

All-Welded Check Valves

CW Series

Features

- Internally threadless and all-welded design
- Forward flow starts at less than 2 psig (0.14 bar) pressure differential
- Valve closes with less than 2 psig (0.14 bar) back pressure
- Standard surface roughness finished to an average of Ra 20 $\mu\text{in.}$ (0.51 μm) or electropolished to Ra 10 $\mu\text{in.}$ (0.25 μm) optional
- Variety of end connections available



Technical Data

Ports Size	1/4" to 1/2" or 6 mm to 12 mm
Flow Coefficient (Cv)	0.55 or 0.70
Cracking Pressure ^①	Less than 2 psig (0.14 bar)
Max. Working Pressure	3000 psig (206 bar)
Max. Pressure Drop	145 psig (10 bar)
Working Temperature	-10~400°F (-23~204°C)

① For valves not actuated for a period of time, initial cracking pressure may be higher than the set cracking pressure.

Flow Data

Air @ 70°F (21°C)

Pressure Drop to Atmosphere psi (bar)	Cv 0.55 (l/min)	Cv 0.70 (l/min)
10 (0.68)	170	220
50 (3.4)	450	590
100 (6.8)	820	1040

Product Technology Grade

Product Grade Technology	General Purpose	Special Cleaning and Packaging (F2)	Ultra High Purity (F3)
Material/Specification	316L SS/ASTM A479		316L SS/ASTM A479 316L VAR/SEMI F20
Wetted Surface Roughness	Ra 20 $\mu\text{in.}$ (0.51 μm)		Ra 10 $\mu\text{in.}$ (0.25 μm)
Polishing Process	Machine finished		Electropolished
Process Specification	FC-01 Standard Cleaning and Packaging	FC-02 Special Cleaning and Packaging	FC-03 Ultra High Purity Process Specification
Cleaning	Thrice degreasing ultrasonic cleaning	Special cleaning with non-ozone-depleting chemicals	Ultra high purity cleaning in continuously monitored ultrasonic cleaning system with deionized water
Assembly Environment	At atmosphere	In specially cleaned areas	In ISO Class 5/Federal Class 100 cleanroom
Packaging	Individually bagged	Double bagged	Double bagged and vacuum sealed in cleanroom

Major Materials of Construction

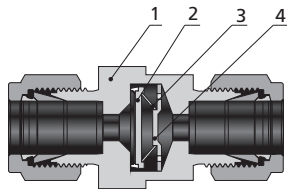

Component	Material Grade/ASTM Specification	
1	Body	316L SS/A479
2	Poppet	Fluorocarbon FKM-bonded 316 SS/A479
3	Belleville Spring	Hastelloy
4	Poppet Stop	316L SS/A240

Note: Check valves are designed for directional flow control only and should never be used as code safety relief devices.

Dimensions

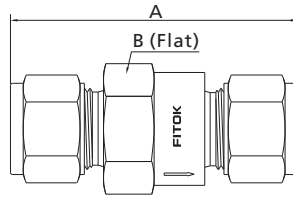

Basic Ordering Number	Connection Type and Size		Cv	Dimensions, in. (mm)	
	Inlet	Outlet		A	B
CW□□-TB4	1/4" TB	1/4" TB	0.55	1.24 (31.5)	7/8 (22.22)
CW□□-TB6	3/8" TB	3/8" TB	0.70		
CW□□-TB8	1/2" TB	1/2" TB	0.55		
CW□□-MTB6	6 mm MTB	6 mm MTB	0.55	1.80 (45.7)	1 (25.4)
CW□□-FR4	1/4" Male FR	1/4" Male FR	0.70		
CW□□-FR8	1/2" Male FR	1/2" Male FR	0.55	2.06 (52.3)	1 (25.4)
CW□□-FL4	1/4" FITOK	1/4" FITOK	0.55	1.96 (49.8)	7/8 (22.22)
CW□□-ML6	6 mm FITOK	6 mm FITOK			

Ordering Number Description

CW6L - FL8 - ML10 - B - F2

Series	Body Material	Inlet Type	Inlet Size	Outlet Type	Outlet Size	Seal Material	Technology Grade
CW	6L 316L SS 6LV 316L VAR SS	FL Fractional Tube Fitting ML Metric Tube Fitting FFR Female FR Fitting FR Male FR Fitting RFR Rotatable Male FR Fitting TB Fractional Tube Butt Weld MTB Metric Tube Butt Weld	4 1/4" 6 3/8" or 6 mm 8 1/2" or 8 mm 10 10 mm 12 12 mm	Same as Inlet Specified in the same way as the inlet type and size		Fluorocarbon FKM B Buna N E EPDM	General Purpose F2 Special Cleaning and Packaging F3 Ultra High Purity

Regulators

FHR-1 Series High Performance High Purity Regulators

Features

- ⦿ 316L stainless steel body for corrosive gases and toxic gases
- ⦿ Standard Hastelloy poppet and diaphragm
- ⦿ Tied diaphragm for added safety
- ⦿ Metal to metal diaphragm to body seal
- ⦿ No springs or threads are exposed to the wetted area
- ⦿ Internal surfaces are finished with Ra 10 μm . (0.25 μm) or Ra 5 μm . (0.13 μm) to ensure minimal particle generation
- ⦿ Every step of assembly, welding, testing, final cleaning and packaging is conducted in Class 100 cleanroom
- ⦿ Ultra High Purity applications



Technical Data

Port Size	1/4" , 3/8" or 1/2"	
Max. Working Pressure	3500 psig	
Outlet Pressure Range	0~30, 0~60, 0~100, 0 ~150 psig	
Flow Coefficient (Cv)	3500 psig Inlet: 0.06 600,1000 psig Inlet: 0.15	
Temperature	PCTFE: -40~149°F (-40~65°C) VespeI: -15~302°F (-26~150°C)	
Leak Rate (Helium)	Internal	$\leq 5 \times 10^{-8}$ mbar l/s
	External	$\leq 1 \times 10^{-9}$ mbar l/s
Weight (regulator only)	≈ 1.5 lbs (0.7 kg)	

Flow Data

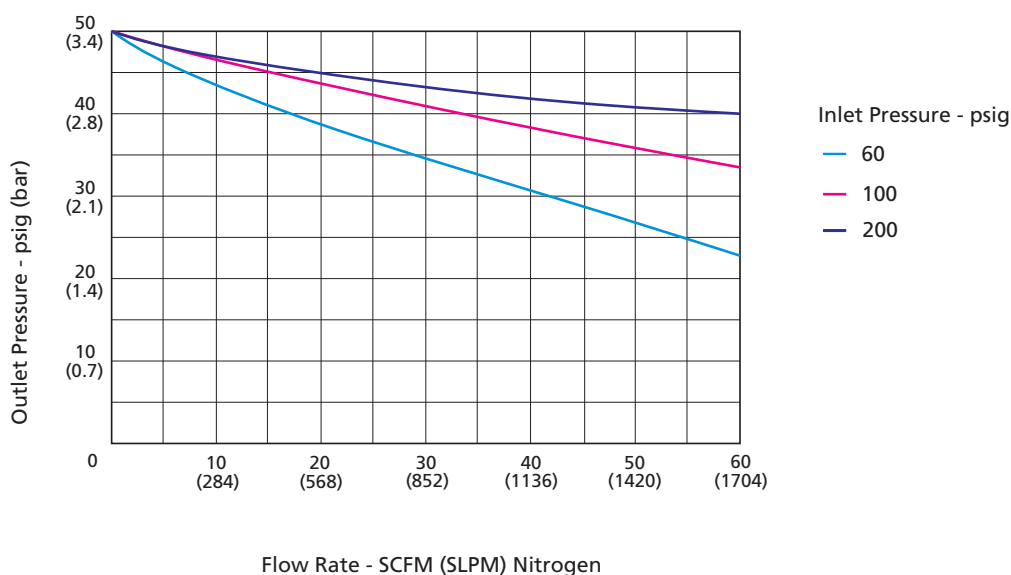

Product Technology Grade

Product Grade Technology	General Purpose	Special Cleaning and Packaging (F2)	Ultra High Purity (F3)
Material/Specification	316L SS/ASTM A479		316L VAR /SEMI F20
Wetted Surface Roughness	Ra 10 µin. (0.25 µm) ^①		Ra 5 µin. (0.13 µm)
Polishing Process	Machine finished ^①		Electropolished
Process Specification	FC-01 Standard Cleaning and Packaging	FC-02 Special Cleaning and Packaging	FC-03 Ultra High Purity Process Specification
Cleaning	Thrice degreasing ultrasonic cleaning	Special cleaning with non-ozone-depleting chemicals	Ultra high purity cleaning in continuously monitored ultrasonic cleaning system with deionized water
Assembly Environment	At atmosphere	In specially cleaned areas	In ISO Class 5/Federal Class 100 cleanroom
Packaging	Individually bagged	Double bagged	Double bagged and vacuum sealed in cleanroom

① For FR connections and tube butt connections, the standard polishing process is electropolishing and the internal surface roughness is finished to an average of Ra 5 µin. (0.13 µm).

Major Materials of Construction

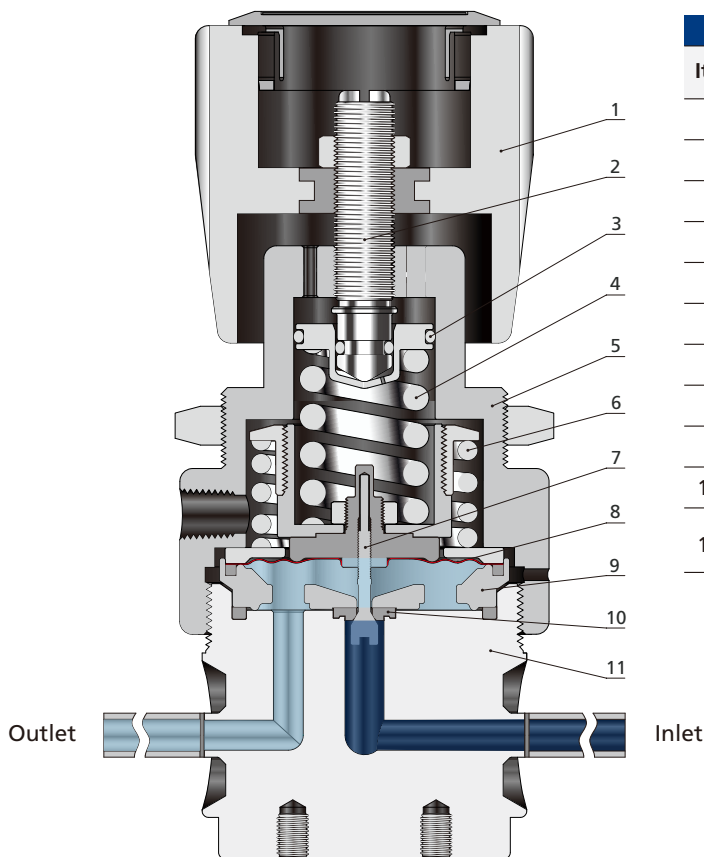

Item	Component	Material/Specification
1	Handle	Aluminum
2	Stem	C36000/ASTM B16
3	O-ring	Viton
4	Range Spring	S17700/ASTM A313
5	Bonnet	304 SS/ASTM A479
6	Back Move Spring	302 SS/ASTM A313
7	Lift Poppet	N06022/ASTM B574
8	Diaphragm	Hastelloy
9	Support	316L SS/ASTM A479
10	Seat	PCTFE/ASTM D1430 or Vespel
11	Body	316L SS/ASTM A479 or 316L VAR /SEMI F20 or 316L VIM-VAR /SEMI F20

Porting Configurations

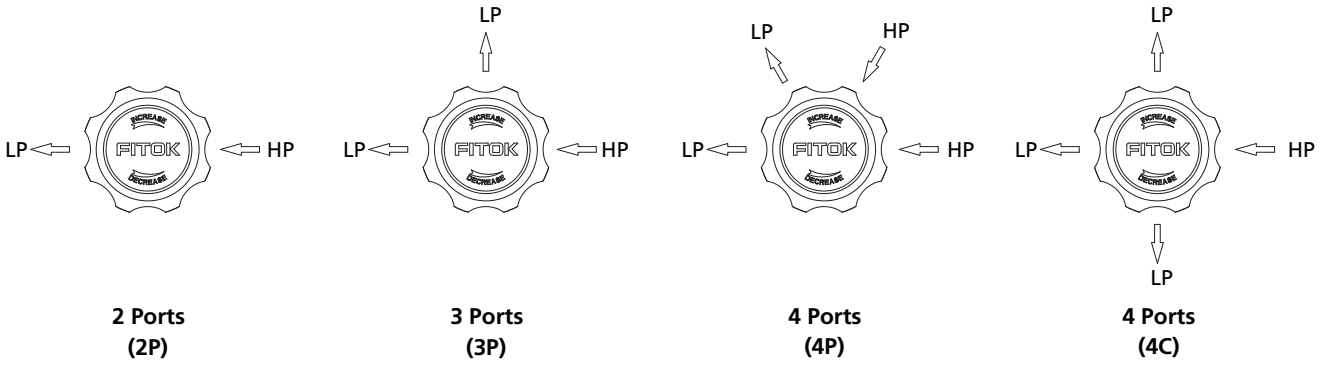

Dimensions

Dimensions, in inches (millimeters), are for reference only.

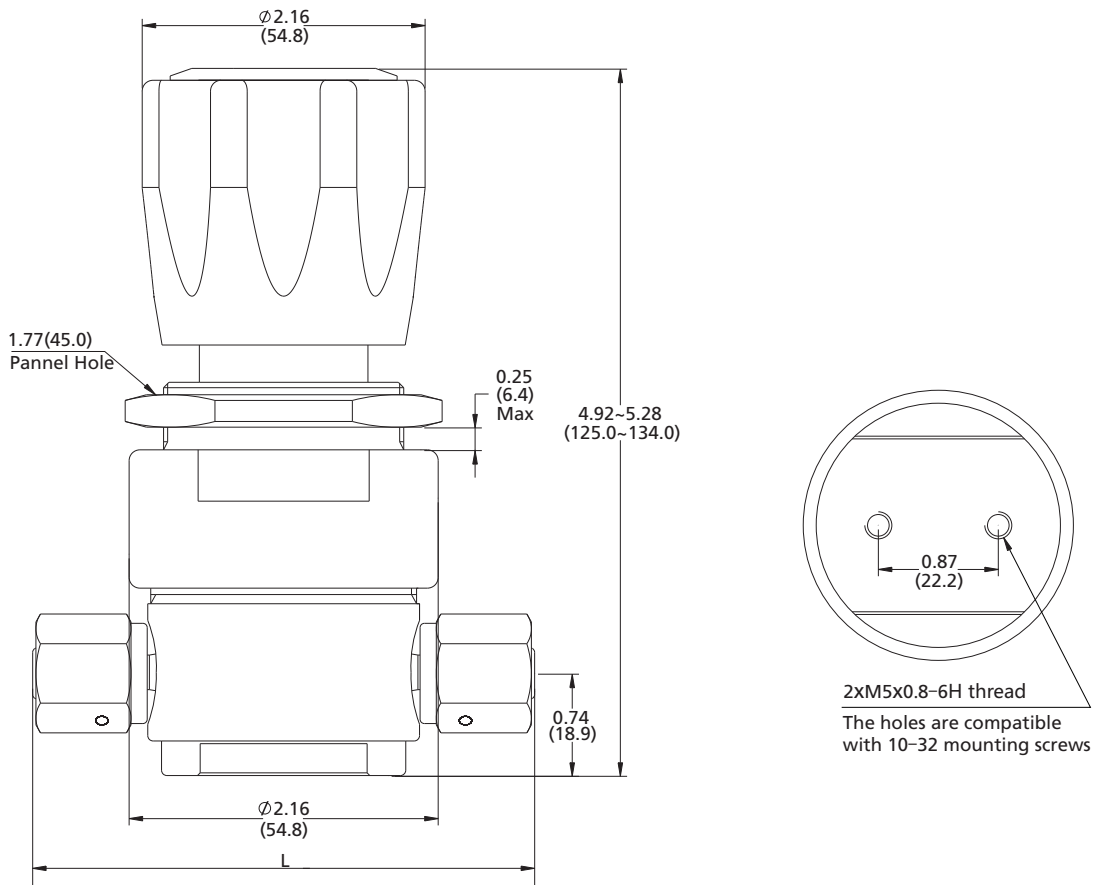

Connection Code	Connection Type and Size	L
C4	1/4" Fractional Tube Fitting	4.97" (126.2)
C6	3/8" Fractional Tube Fitting	5.99" (152.1)
T4	1/4" Fractional Tube Butt Weld	3.70 (94.0)
T6	3/8" Fractional Tube Butt Weld	
F4	1/4" Female Face Seal	4.75" (120.6)
F8	1/2" Female Face Seal	
M4	1/4" Rotatable Male Face Seal	3.70 (94.0)
M8	1/2" Rotatable Male Face Seal	4.75" (120.6)
IF4	1/4" Internal Female Face Seal	1.09" (27.7)

Ordering Number Description

FHR - 16L - 35 - 100 - 4P - B - M4M4M4M4 - ZV - F2

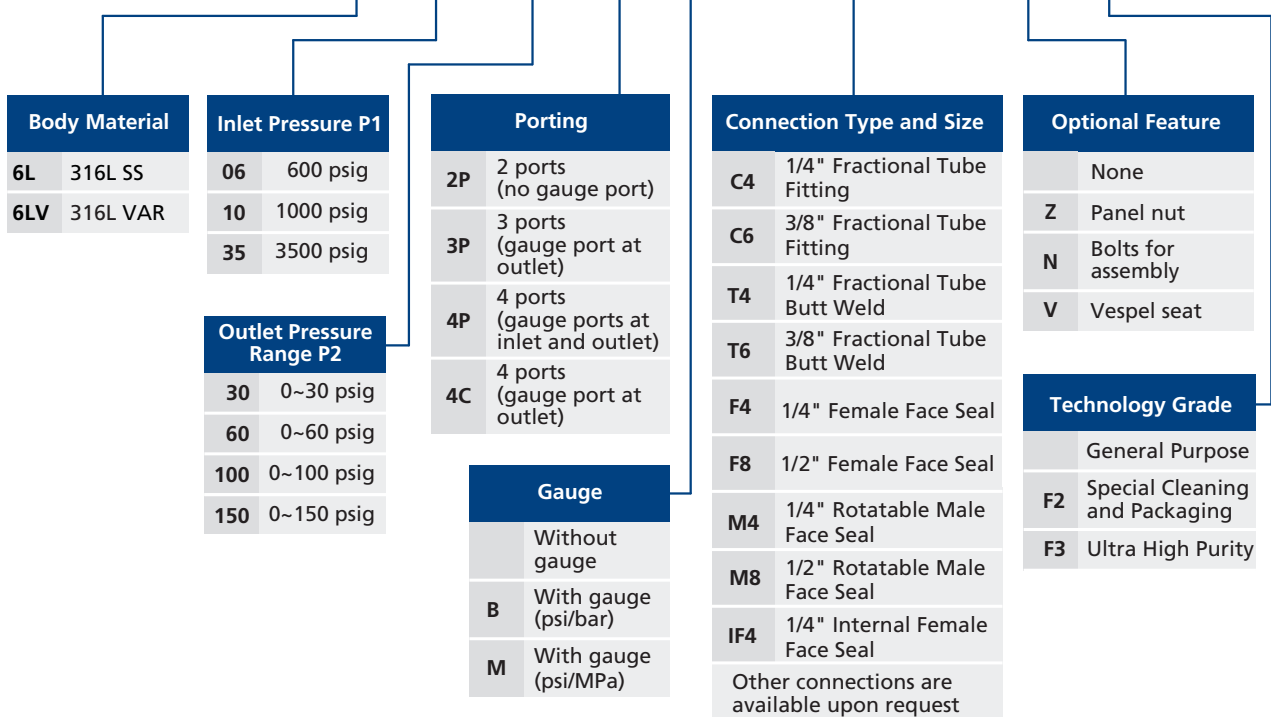

Note: "Ordering Number Description" is a reference to understand the combination rules of FITOK product part number. Not all combinations are available.

Warranty Information

FITOK products are backed by the FITOK Limited Lifetime Warranty. For a copy, contact FITOK Group or our authorized distributors.

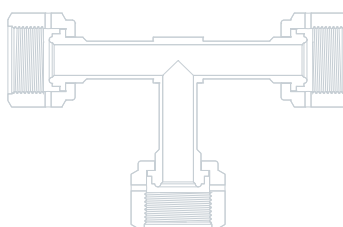
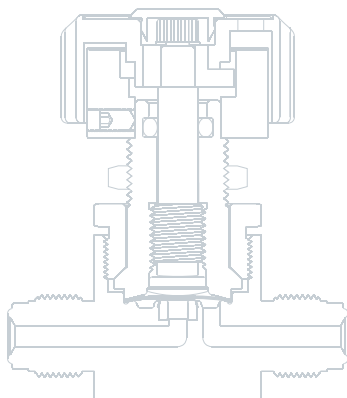
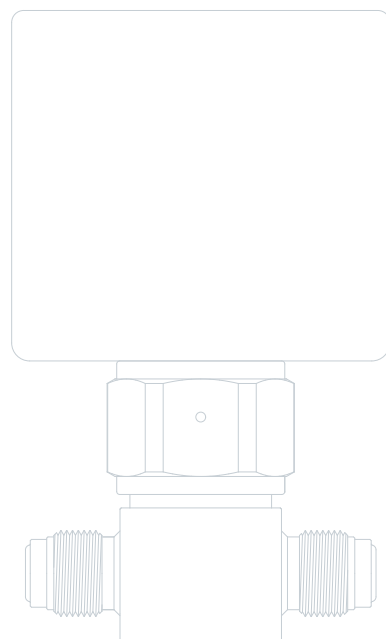
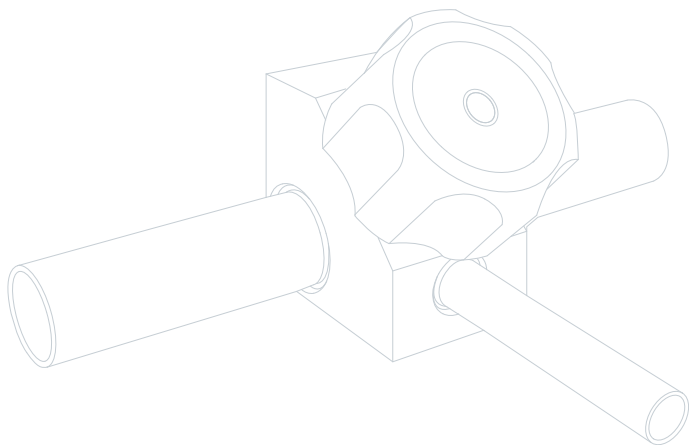

FITOK Group

FITOK GmbH (Headquarter)

Sprendlinger Landstr. 115, 63069 Offenbach am Main, Germany
 Tel.: +49 69 8900 4498 Fax: +49 69 8900 4495

FITOK, Inc.

13843 North Promenade Blvd., Suite 750, Stafford, Texas 77477, USA
 Tel.: +1 281 888 0077 Fax: +1 281 582 4051

FITOK Incorporated

Block C, Zone E, Yingtai Industrial Park, Dalang Street,
 Longhua District, Shenzhen, 518109, China
 Tel.: +86 755 2803 2500 Fax: +86 755 2803 2619

FITOK Middle East Oil Equipment Trading LLC

208-209, Makateb Building, P.O.Box 185412, Airport Road, Deira, Dubai, UAE
 Tel.: +971 4 2959 853 Fax: +971 4 2959 854

info@fitokgroup.com
 www.fitokgroup.com

