

Gauge Valves and Instrumentation Manifolds

GV, GVH, GR Series

2-valve, 3-valve and 5-valve Manifold Series

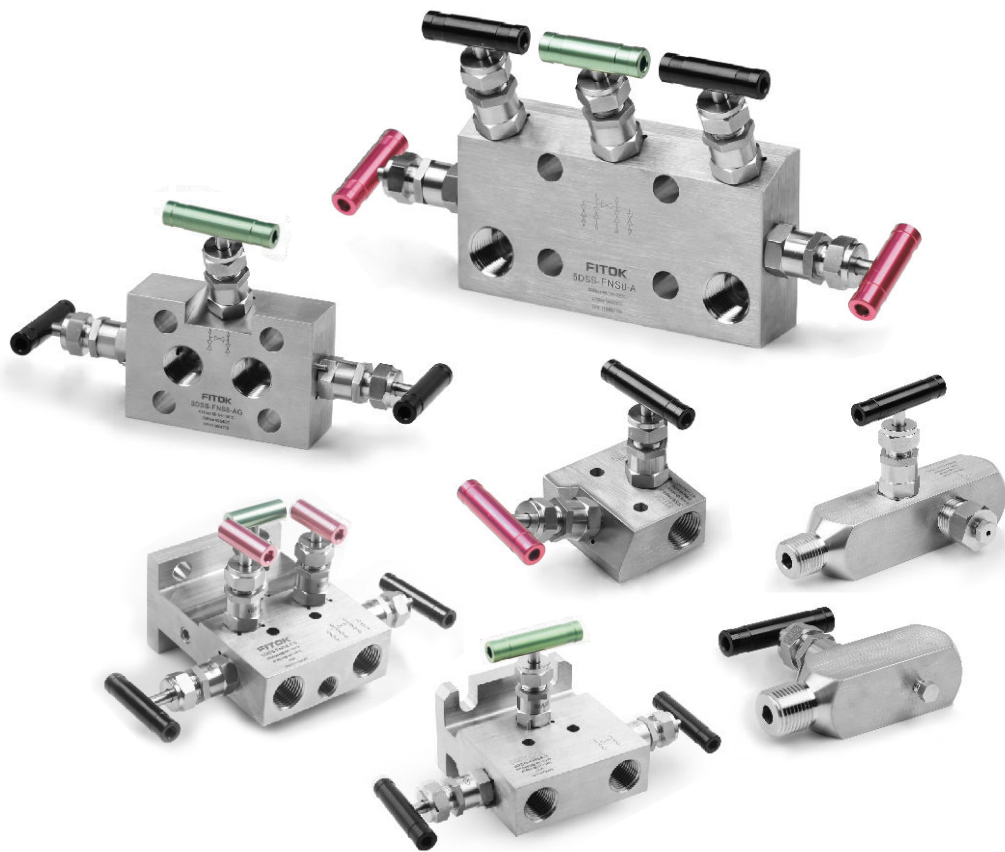

Contents

Gauge Valves

GV Series, GVH Series and GR Series



C-04

Instrumentation Manifolds

2-valve Manifolds

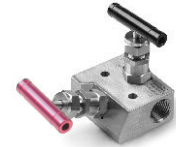

C-09

3-valve Manifolds



C-12

5-valve Manifolds



C-14

C Integral Manifolds

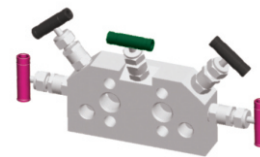

C-18

Accessories

Manifold Bracket Supports

C-21

Kidney Flange / Eccentric Flange

C-21

Bleed Valves

C-22

Calibration Fittings

C-22

Gauge Valves

GV Series, GVH Series and GR Series

Features

- ⦿ Working pressure up to:
 - Stainless steel: GV, GR up to 6000 psig (414 bar)
 - GVH up to 10000 psig (690 bar)
- ⦿ GV Series and GVH Series working temperature:
 - PTFE packing: -65°F to 450°F (-54°C to 232°C)
 - Graphite packing: -65°F to 1200°F (-54°C to 649°C)
- ⦿ GR Series working temperature:
 - Acetal seat: -20°F to 250°F (-28°C to 121°C)
 - PEEK seat: -20°F to 400°F (-28°C to 204°C)
- ⦿ Non-rotating lower stem, ball tip and plug tip designs
- ⦿ Variety of materials for seat and packing
- ⦿ Safety back seating seals in fully open position
- ⦿ Rolled spindle operating threads
- ⦿ Lubricant for stem thread isolated from the media
- ⦿ Externally adjustable gland
- ⦿ Bonnet locking pin fitted as standard
- ⦿ Low torque operating T bar handle
- ⦿ Option for different colored handles
- ⦿ Steady and durable fastening of the handle by double lock-pins
- ⦿ Each GV/GR Series gauge valve leak tested with Nitrogen or compressed air at the maximum working pressure, each GVH Series gauge valve leak tested with water at 1.1 times the maximum working pressure

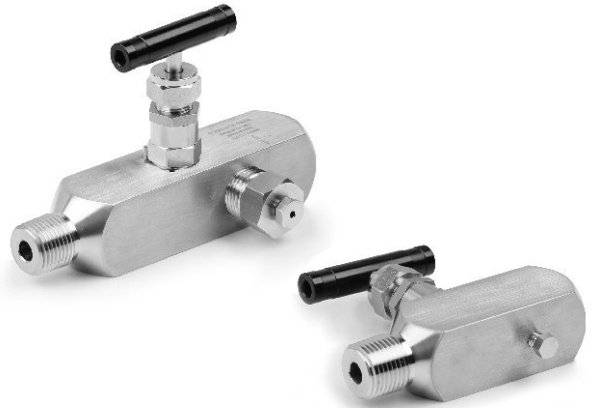

Standard Materials of Construction

Item	Component	Valve Body Material	
		316 SS	
		Material Grade/ASTM Specification	
1	Handle	6061/B211	
2	Set Screw	Stainless steel	
3	Packing Bolt	304 SS/A479	
4	Upper Stem	316 SS/A479	
5	Lock Nut	Stainless steel	
6	Bonnet	316 SS/A479	
7	Gland	316 SS/A479	
8	Packing	PTFE or graphite	
9	Lock Pin	Stainless steel	
10	Lower Stem	Hardened 316 SS/A479	
11	Body	316 SS/A479 316 SS/A182	
12	Seat	Acetal or PEEK	
	Lubricant	Molybdenum disulfide-based	

Ball Tip Design Valves (GV, GVH)

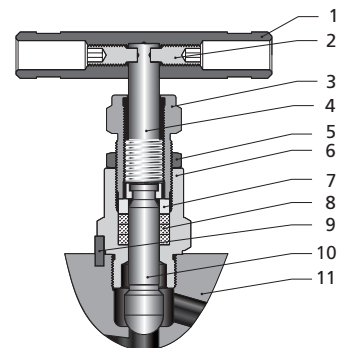

Plug Tip Design Valves (GR)

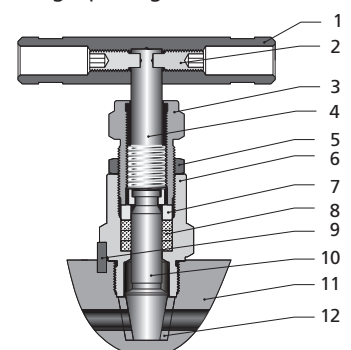

Process interface valves for sour gas service are available. Materials are selected in accordance with NACE MR0175/ISO 15156. Contact FITOK Group or our authorized distributors if you have any request.

Pressure vs. Temperature

GV Series Ball Tip Design Gauge Valves

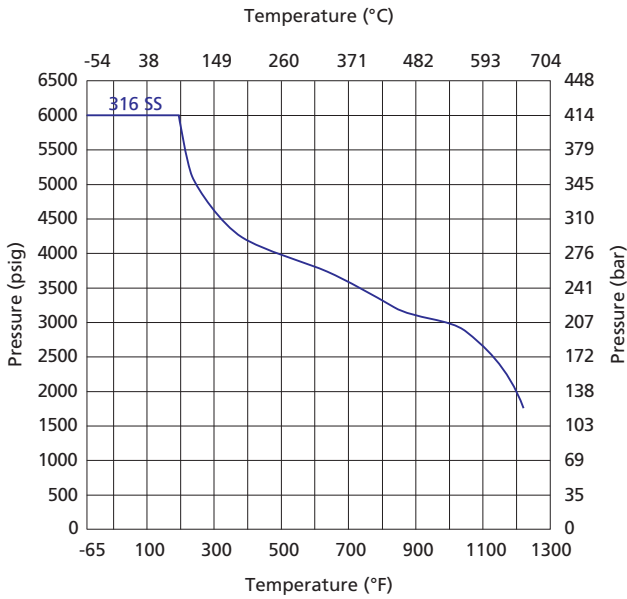

GVH Series Ball Tip Design Gauge Valves

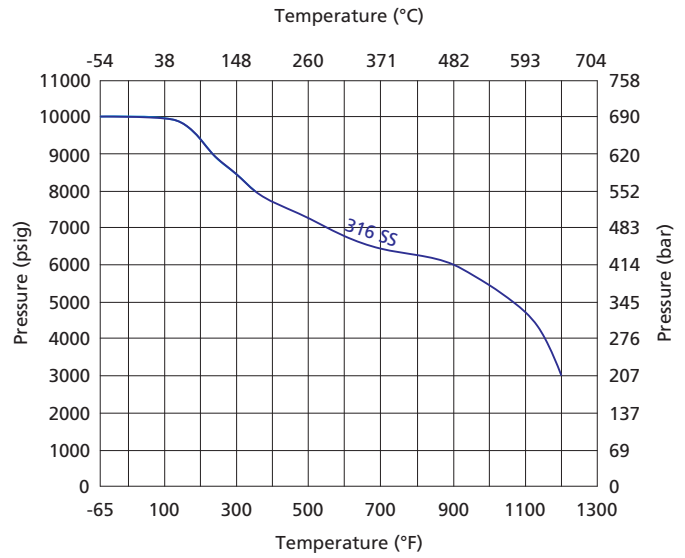

Based on graphite packing.

GR Series Plug Tip Design Gauge Valves

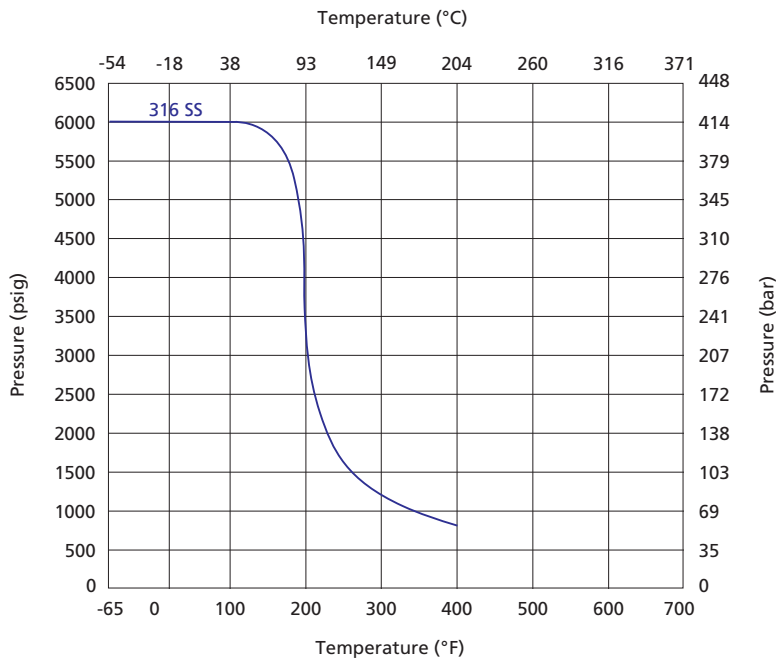

1. For manifolds of Acetal seat, the maximum medium temperature is 250°F (121°C), not recommended for temperature higher than 200°F (93°C) for water and steam application.
2. Based on PEEK seat and PTFE packing.

Types and Dimensions

Standard Type

Basic Ordering Number	Design	Inlet/Process	Outlet/Instrument	Test/Vent/Plug
GV□□-NS8-FNS8	Ball Tip	1/2 Male NPT	1/2 Female NPT	1/2 Female NPT
GVH□□-NS8-FNS8				
GR□□-NS8-FNS8	Plug Tip			
GV□□-NS12-FNS8	Ball Tip	3/4 Male NPT	1/2 Female NPT	1/2 Female NPT
GVH□□-NS12-FNS8				
GR□□-NS12-FNS8	Plug Tip			

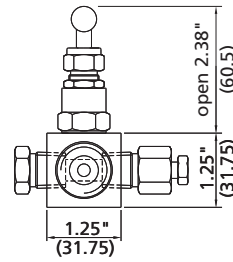
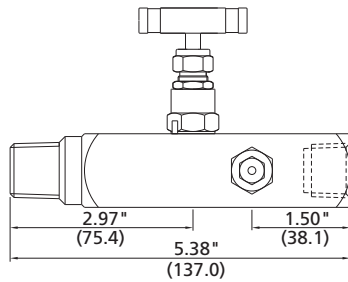
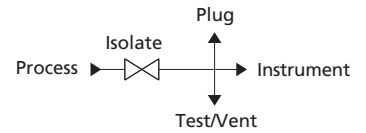

The dimensions shown are for GV series gauge valves. If you need the dimensions of GVH series, please contact FITOK Group.

Lagging Extension Body Type

Basic Ordering Number	Inlet/Process	Outlet/Instrument	Test/Vent/Plug
GV□□-NS8-FNS8-E	1/2 Male NPT	1/2 Female NPT	1/2 Female NPT
GVH□□-NS8-FNS8-E			
GR□□-NS8-FNS8-E			

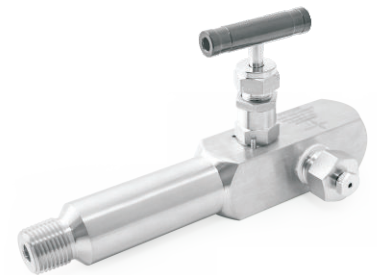
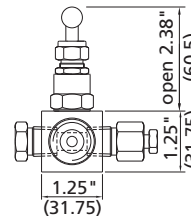
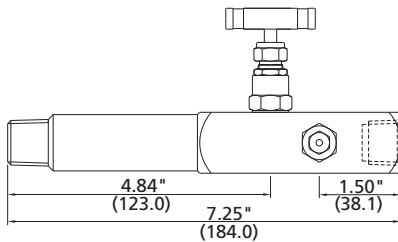
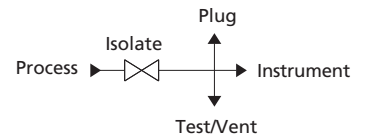

Lagging extension body is inserted through pipe insulation.

The dimensions shown are for GV series gauge valves. If you need the dimensions of GVH series, please contact FITOK Group.

Miniature Type

Basic Ordering Number	Inlet/Process	Outlet/Instrument	Vent
GV□□-NS8-FNS8-C	1/2 Male NPT	1/2 Female NPT	Vent stem
GVH□□-NS8-FNS8-C			
GR□□-NS8-FNS8-C			

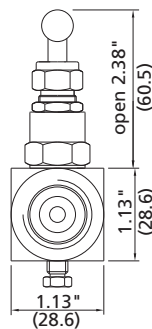
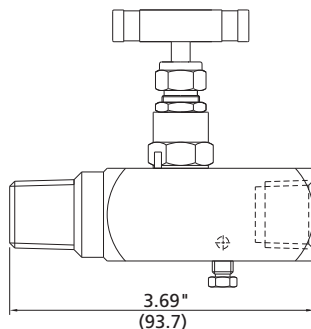
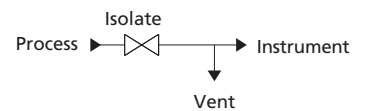

The dimensions shown are for GV series gauge valves. If you need the dimensions of GVH series, please contact FITOK Group.

Ordering Number Description

GRSS – NS8 – FNS8 – CPW – GR – SF2

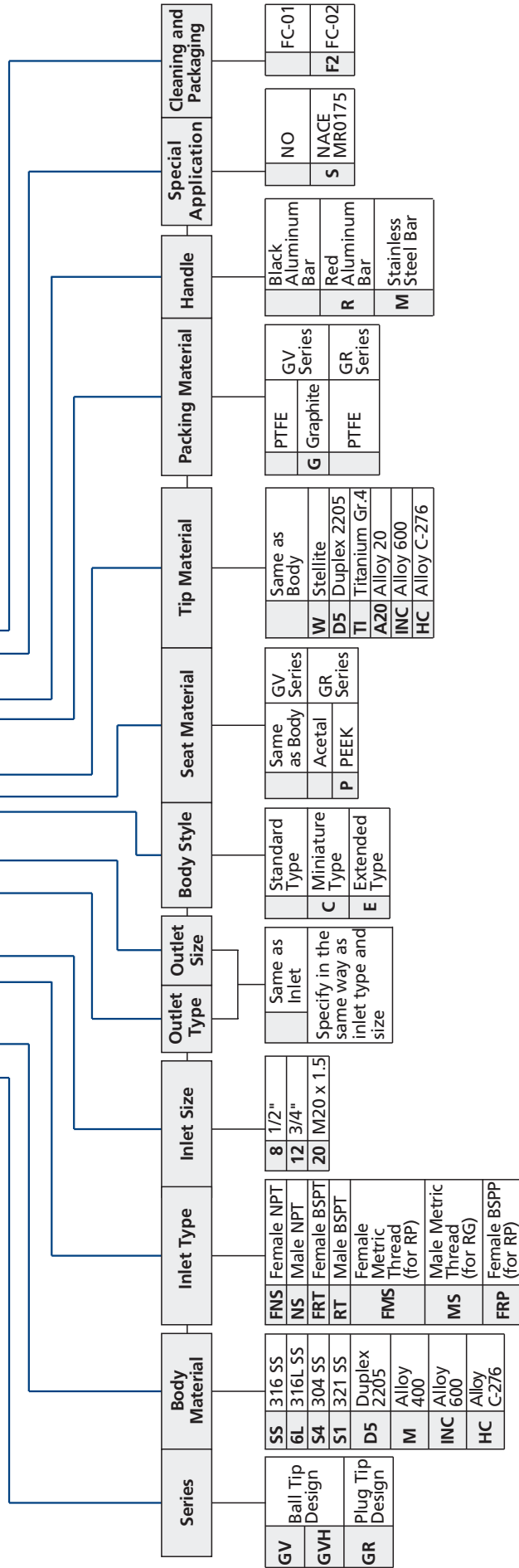

Note: "Ordering Number Description" is a reference to understand the combination rules of FITOK product part number. Not all combinations are available.

Cleaning and Packaging:

FC-01: Standard cleaning and packaging for general industrial procedures.

FC-02: Special cleaning and packaging for wetted system components to ensure compliance with product cleanliness requirement as stated in ASTM G93 Level C.

Instrumentation Manifolds

Features

- ⦿ Working pressure up to:
 - Stainless steel: 2D, 2R, 3D, 3R, 5D, 5R up to 6000 psig (414 bar)
 - 2DH, 2RH, 3DH, 3RH, 5DH, 5RH up to 10000 psig (690 bar)
 - Alloy C-276: 2D, 2R, 3D, 3R, 5D, 5R up to 6000 psig (414 bar)
- ⦿ Working temperature:
 - PTFE packing: -65°F to 450°F (-54°C to 232°C)
 - Graphite packing: -65°F to 1200°F (-54°C to 649°C)
- ⦿ Orifice: 0.157" (4.0 mm)
- ⦿ Two-piece stem design: Upper stem threads cold rolled and hardened lower stem for high strength and smooth operation
- ⦿ Upper stem thread lubricant isolated from system media
- ⦿ Linear instead of rotary motion of the rising, non-rotating stem minimizes packing abrasion and reduces the friction between the seat and the tip
- ⦿ Safety back seating seals in fully open position
- ⦿ Steady and durable fastening of the handle by double lock-pins
- ⦿ Each 2D/2R/3D/3R/5D/5R Series manifold leak tested with Nitrogen or compressed air at the maximum working pressure, each 2DH/2RH/3DH/3RH/5DH/5RH Series manifold leak tested with water at 1.1 times the maximum working pressure



Pressure vs. Temperature

2D, 2R, 3D, 3R, 5D, 5R Series

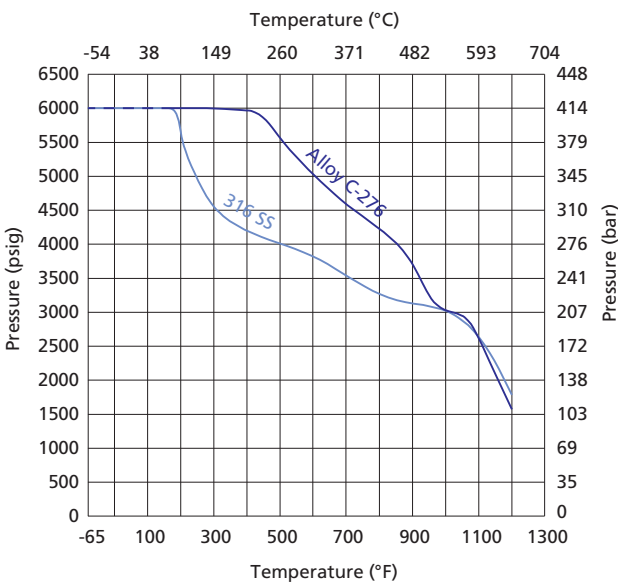

2DH, 2RH, 3DH, 3RH, 5DH, 5RH Series

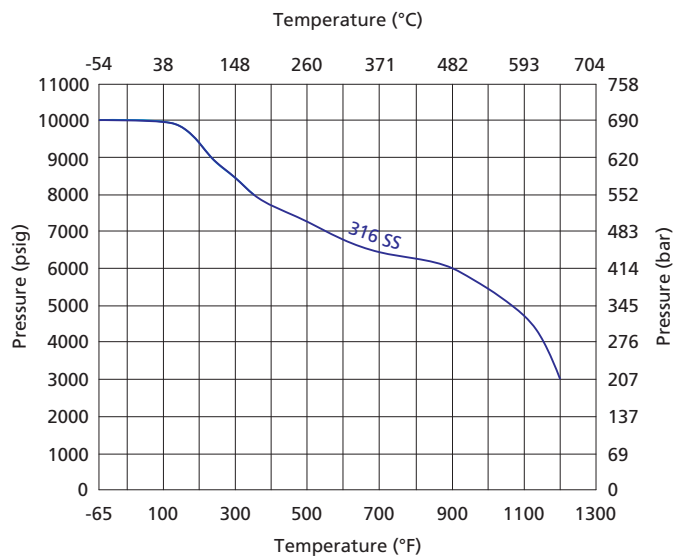

1. Based on graphite packing.
 2. Contact FITOK Group or our authorized distributors for curve graph of other materials.

Standard Materials of Construction

Item	Component	Valve Body Material	
		316 SS	Alloy C-276
		Material Grade/ASTM Specification	
1	Handle	6061/B211	
2	Set Screw	Stainless steel	
3	Packing Bolt	304 SS/A479	
4	Upper Stem	316 SS/A479	
5	Lock Nut	Stainless steel	
6	Bonnet	316 SS/A479	Alloy C-276/B574
7	Gland	316 SS/A479	
8	Packing	PTFE or Graphite	
9	Lock Pin	Stainless steel	
10	Lower Stem	Hardened 316 SS/A479	Alloy C-276/B574
11	Body	316 SS/A479 316 SS/A182	Alloy C-276/B564
Lubricant		Molybdenum disulfide-based	

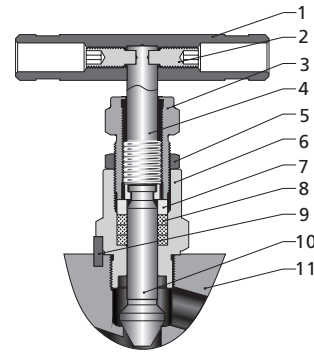

Handle colors indicate function:
 BLACK=Isolate/block
 RED=Test/vent
 GREEN=Equalize

Process interface valves for sour gas service are available. Materials are selected in accordance with NACE MR0175/IISO 15156. Contact FITOK Group or our authorized distributors if you have any request.

Design Standards

- Instrumentation manifolds are designed and manufactured in accordance with ASME B31.3 and MSS-SP-105. Flange design meets the requirements of MSS SP-99.
- 2-valve manifold is used with pressure gauges or pressure transmitters.
- 3-valve and 5-valve manifolds are used with differential pressure transmitters.

Types and Dimensions

2-valve Manifolds

Consist of one block valve and one bleed valve

Basic Ordering Number	Inlet/Process	Outlet/Instrument	Test/Vent
2D□□-FNS8-A	1/2 Female NPT	Flange	1/4 Female NPT
2DH□□-FNS8-A			

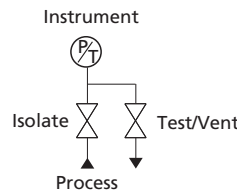
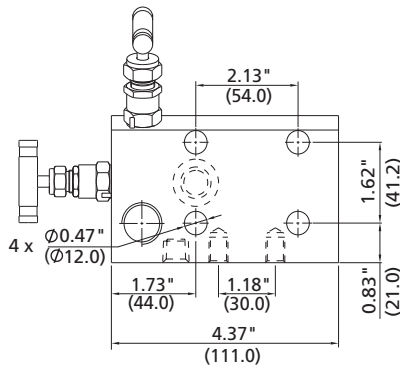
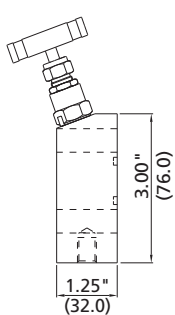

- Notes: 1. Every manifold is supplied with one PTFE sealing ring for manifold-to-instrument and four 7/16" UNF x 1.75" high tensile bolts
 2. Dimensions shown are for 2D Series manifolds. For dimensions of 2DH Series manifolds, please contact FITOK Group or our authorized distributors

C-10 Gauge Valves and Instrumentation Manifolds

Basic Ordering Number	Inlet/Process	Outlet/Instrument	Test/Vent
2D□□-FNS8-L	1/2 Female NPT	Flange	1/4 Female NPT

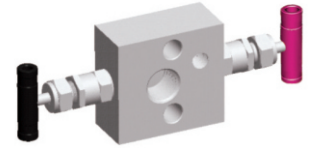
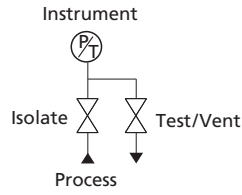
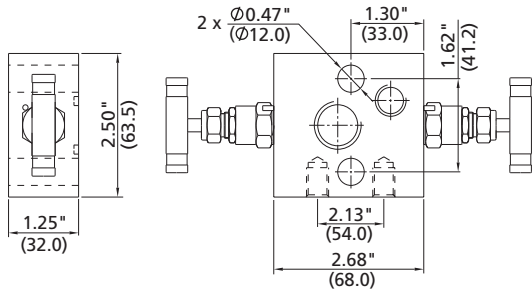

Every manifold is supplied with one PTFE sealing ring for manifold-to-instrument and two 7/16" UNF x 1.75" high tensile bolts.

Basic Ordering Number	Inlet/Process	Outlet/Instrument	Test/Vent
2D□□-FNS8-V	1/2 Female NPT	Flange	1/4 Female NPT

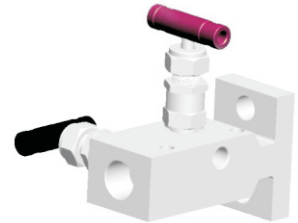
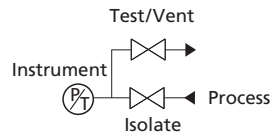
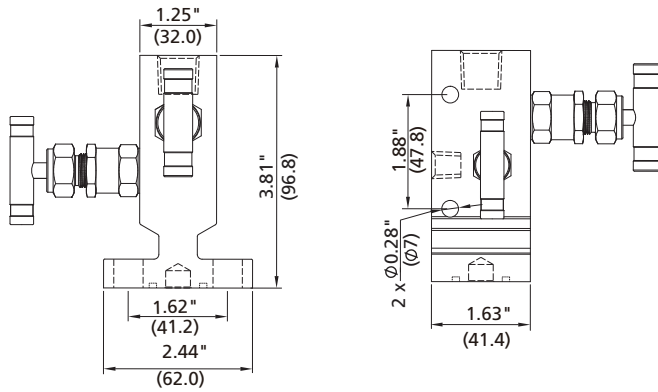

Every manifold is supplied with one PTFE sealing ring for manifold-to-instrument and two 7/16" UNF x 24 mm high tensile bolts.

Basic Ordering Number	Inlet/Process	Outlet/Instrument	Test/Vent
2R□□-FNS4-A	1/4 Female NPT	1/4 Female NPT	1/4 Female NPT
2RH□□-FNS4-A			

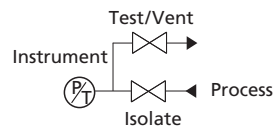
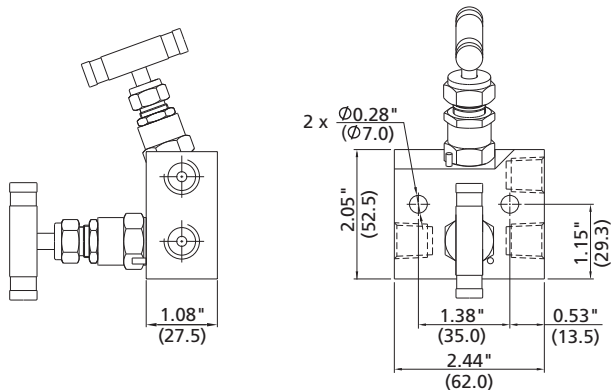

Dimensions shown are for 2R Series manifolds. For dimensions of 2RH Series manifolds, please contact FITOK Group or our authorized distributors.

Basic Ordering Number	Inlet/Process	Outlet/Instrument	Test/Vent
2R □□ -FNS8-L	1/2 Female NPT	1/2 Female NPT	1/4 Female NPT

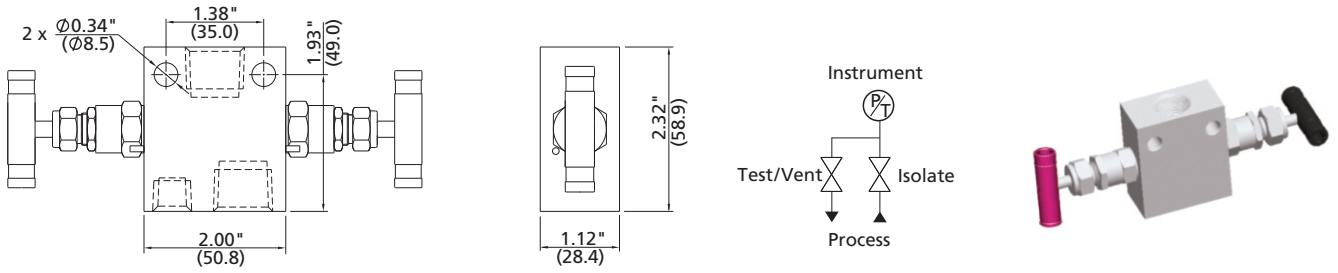

Basic Ordering Number	Inlet/Process	Outlet/Instrument	Test/Vent
2R □□ -FNS8-NS8-H	1/2 Female NPT	1/2 Male NPT	1/4 Female NPT
2RH □□ -FNS8-NS8-H			
2R □□ -NS8-H	1/2 Male NPT	1/2 Male NPT	1/4 Female NPT
2RH □□ -NS8-H			

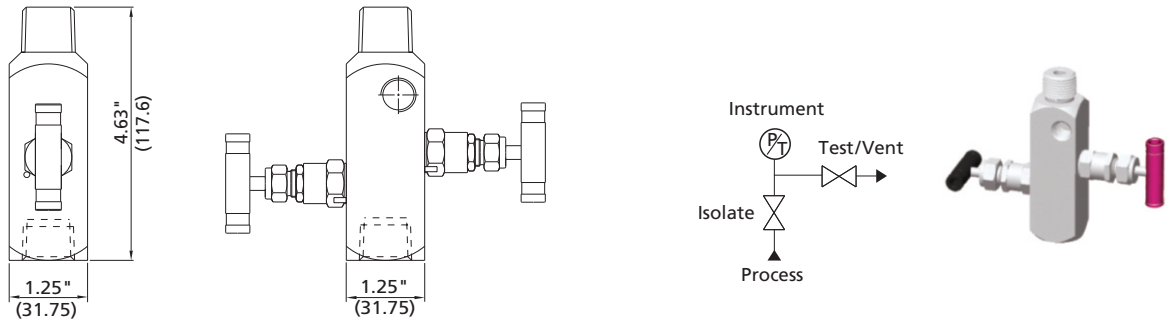

Dimensions shown are for 2R Series manifolds. For dimensions of 2RH Series manifolds, please contact FITOK Group or our authorized distributors.

Basic Ordering Number	Inlet/Process	Outlet/Instrument	Test/Vent
2R □□ -FNS8-V	1/2 Female NPT	1/2 Female NPT	1/4 Female NPT

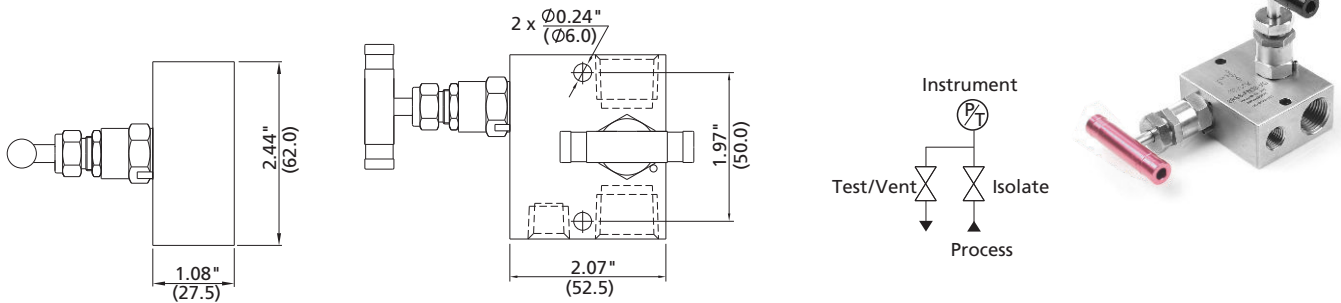

Manifolds

3-valve Manifolds

Consist of two block valves and one equalizer valve

Basic Ordering Number	Inlet/Process	Outlet/Instrument
3D □□ -FNS8-A	1/2 Female NPT	Flange
3DH □□ -FNS8-A		
3D □□ -FL8-A	1/2" FITOK	Flange

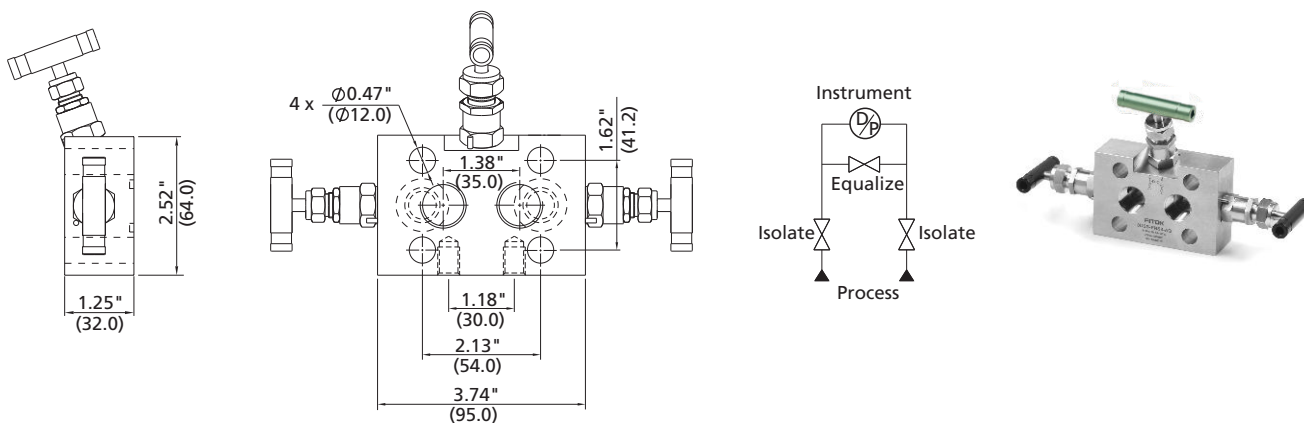

- Notes: 1. Every manifold is supplied with two PTFE sealing rings manifold-to-instrument and four 7/16" UNF x 1.75" high tensile bolts.
 2. FL8 connections are obtained by adding an extra CM tube fitting to the FNS8 connections.
 3. Dimensions shown are for 3D Series manifolds. For dimensions of 3DH Series manifolds, please contact FITOK Group or our authorized distributors.

Basic Ordering Number	Inlet/Process	Outlet/Instrument	Test/Vent
3D □□ -FNS8-L	1/2 Female NPT	Flange	Optional
3D □□ -FL8-L	1/2" FITOK	Flange	Optional

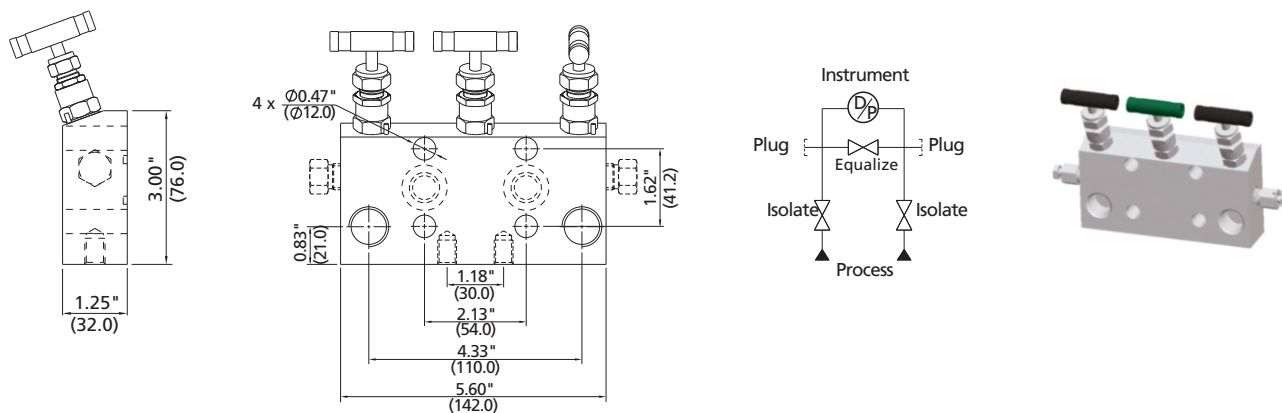

- Notes: 1. Every manifold is supplied with two PTFE sealing rings for manifold-to-instrument and four 7/16" UNF x 1.75" high tensile bolts.
 2. FL8 connections are obtained by adding an extra CM tube fitting to the FNS8 connections.

Basic Ordering Number	Inlet/Process	Outlet/Instrument	Test
3D□□-FNS8-V	1/2 Female NPT	Flange	Optional

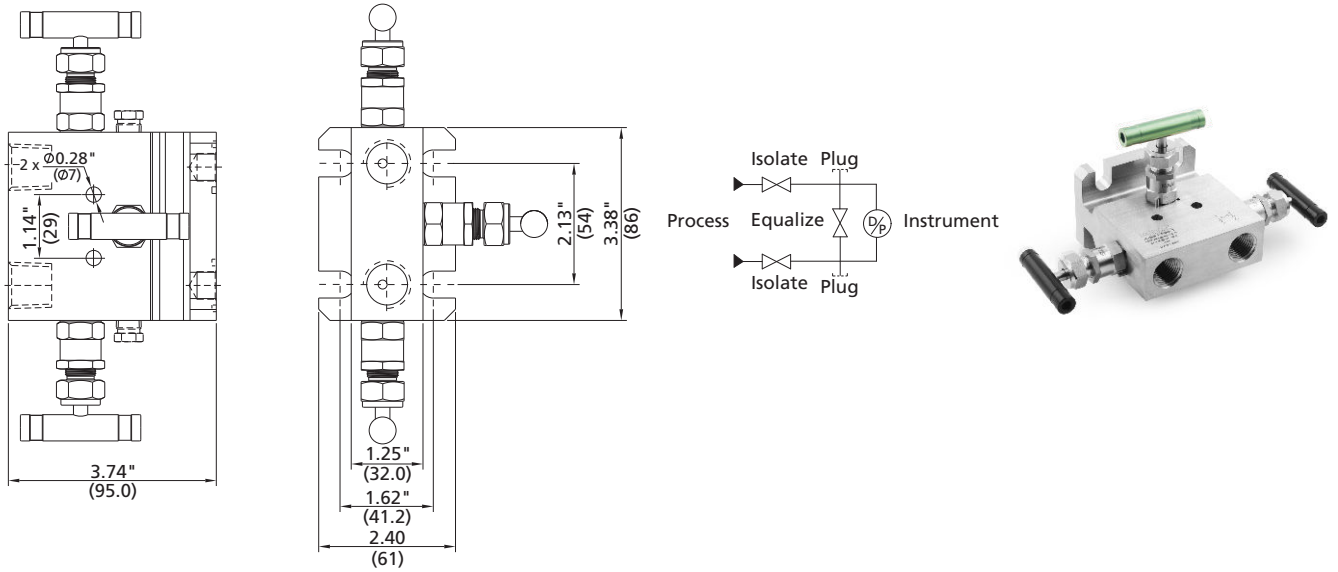

Every manifold is supplied with two PTFE sealing ring for manifold-to-instrument and four 7/16" UNF x 24 mm high tensile bolts.

Basic Ordering Number	Inlet/Process	Outlet/Instrument	Test
3D□□-F-V	Flange	Flange	Optional

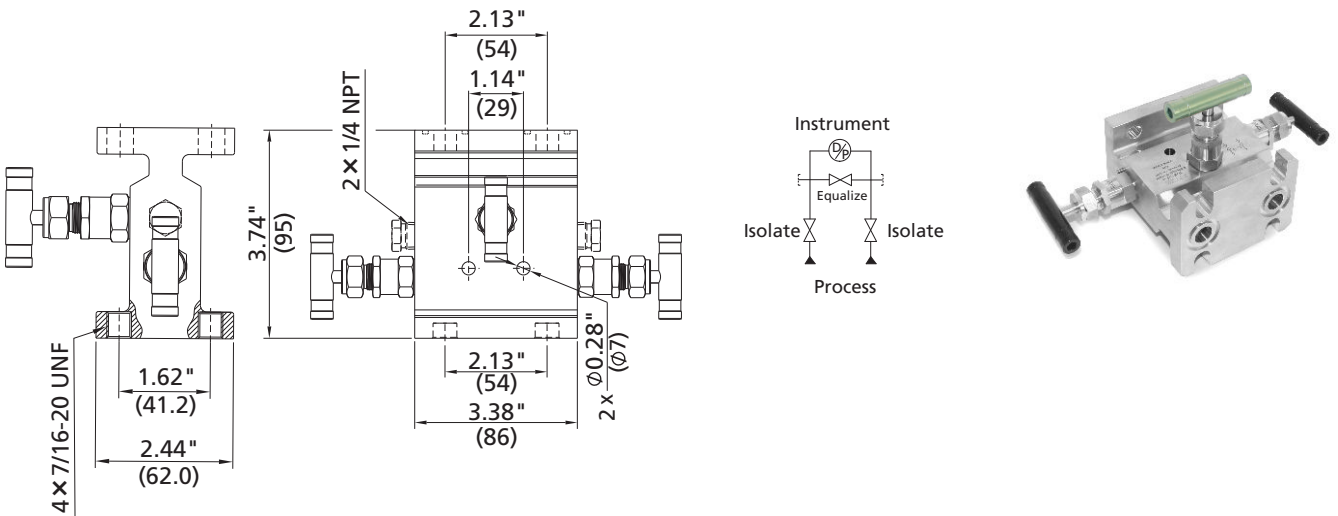

Every manifold is supplied with two PTFE sealing ring for manifold-to-instrument and four 7/16" UNF x 24 mm high tensile bolts.

Manifolds

C-14 Gauge Valves and Instrumentation Manifolds

Basic Ordering Number	Inlet/Process	Outlet/Instrument	Test
3R □□ -FNS8-V	1/2 Female NPT	1/2 Female NPT	Optional
3RH □□ -FNS8-V			
3R □□ -FL8-V	1/2" FITOK	1/2" FITOK	Optional

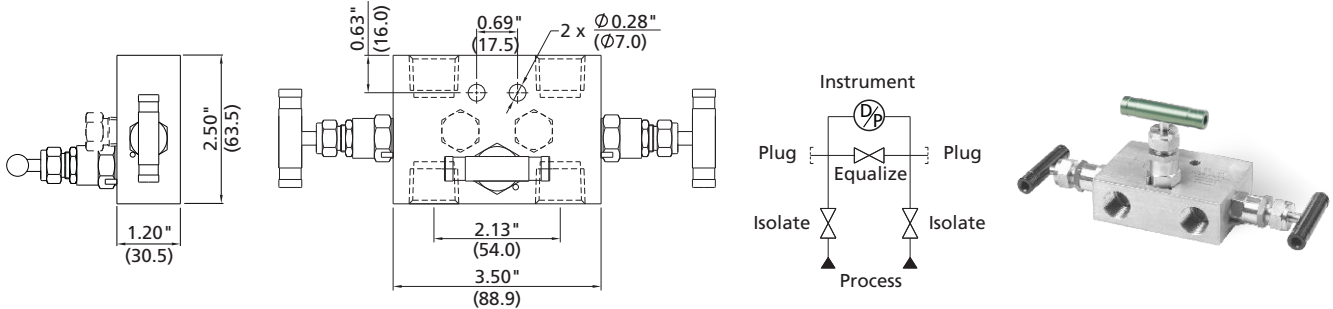

Notes: 1. FL8 connections are obtained by adding an extra CM tube fitting to the FNS8 connections.

2. Dimensions shown are for 3R Series manifolds. For dimensions of 3RH Series manifolds, please contact FITOK Group or our authorized distributors.

5-valve Manifolds

1. 5-valve Manifold of Double-bleed Function:

consist of two block valves, two bleed valves and one equalizer valve

Basic Ordering Number	Inlet/Process	Outlet/Instrument	Test
5D □□ -FNS8-A	1/2 Female NPT	Flange	1/4 Female NPT
5DH □□ -FNS8-A			
5D □□ -FL8-A	1/2" FITOK	Flange	1/4 Female NPT

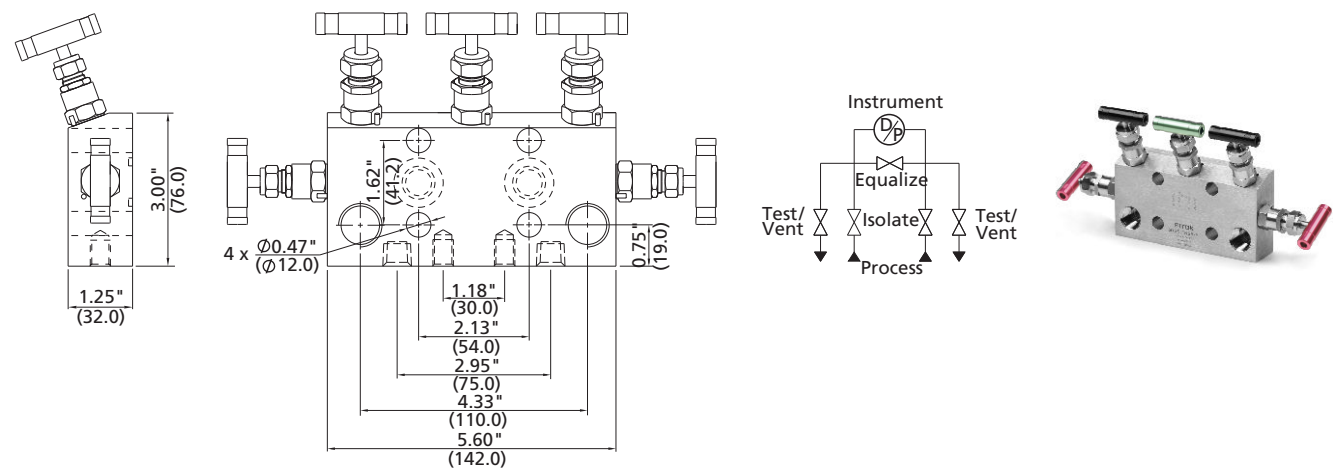

Notes: 1. Every manifold is supplied with two PTFE sealing rings for manifold-to-instrument and four 7/16" UNF x 1.75" high tensile bolts.

2. FL8 connections are obtained by adding an extra CM tube fitting to the FNS8 connections.

3. Dimensions shown are for 5D Series manifolds. For dimensions of 5DH Series manifolds, please contact FITOK Group or our authorized distributors.

Basic Ordering Number	Inlet/Process	Outlet/Instrument	Test/Vent
5D□□-FNS8-V	1/2 Female NPT	Flange	1/4 Female NPT

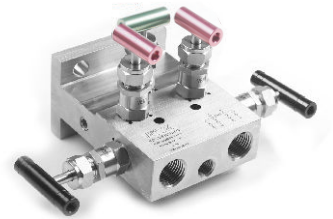
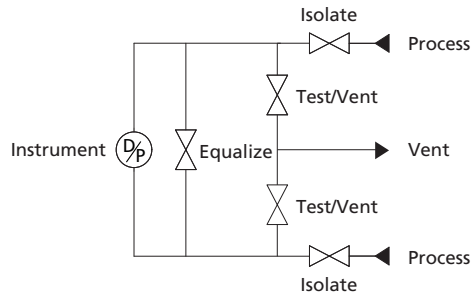
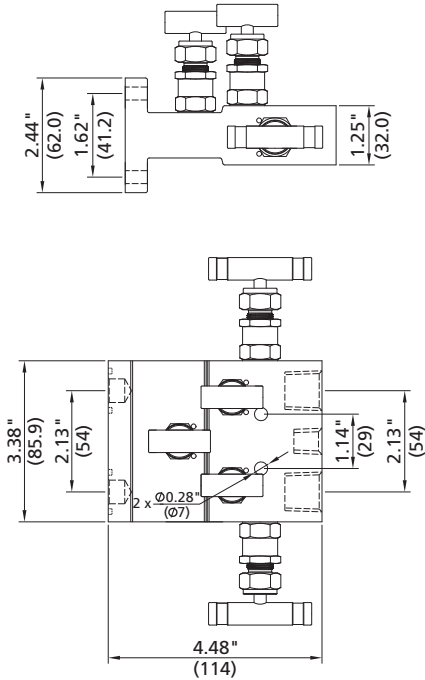

Every manifold is supplied with two PTFE sealing ring for manifold-to-instrument and four 7/16" UNF x 24 mm high tensile bolts.

Basic Ordering Number	Inlet/Process	Outlet/Instrument	Test/Vent
5R□□-FNS8-L	1/2 Female NPT	1/2 Female NPT	1/4 Female NPT
5RH□□-FNS8-L			
5R□□-FL8-FNS8-L	1/2" FITOK	1/2 Female NPT	1/4 Female NPT

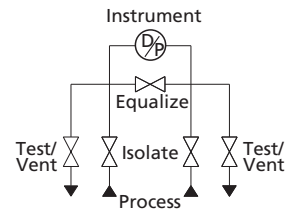
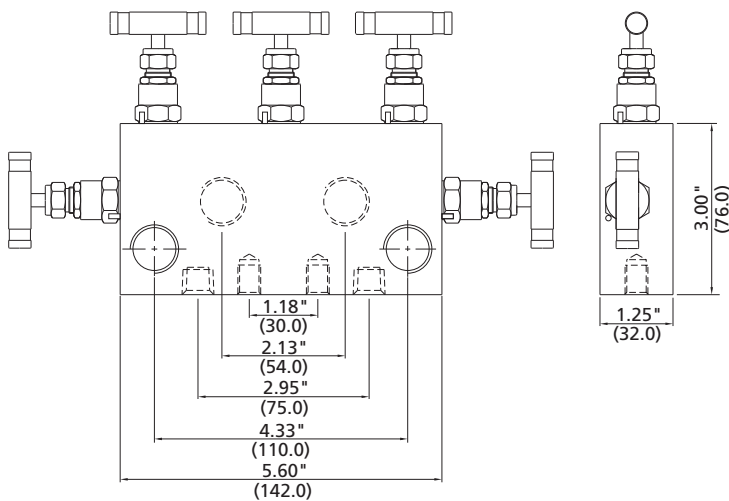

Notes: 1. FL8 connections are obtained by adding an extra CM tube fitting to the FNS8 connections.
 2. Dimensions shown are for 5R Series manifolds. For dimensions of 5RH Series manifolds, please contact FITOK Group or our authorized distributor.

Manifolds

C-16 Gauge Valves and Instrumentation Manifolds

Basic Ordering Number	Inlet/Process	Outlet/Instrument	Test/Vent
5R □□-FNS8-V	1/2 Female NPT	1/2 Female NPT	1/4 Female NPT

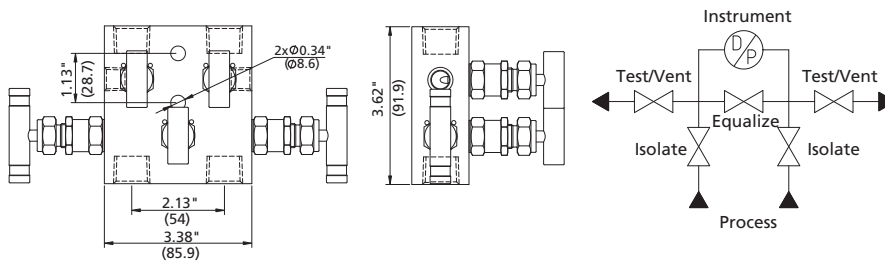

2. 5-valve Custody Transfer/Fiscal Metering Manifold (double-equalizer): consist of two block valves, one bleed valve and two equalizer valves

Basic Ordering Number	Inlet/Process	Outlet/Instrument	Vent	Test
5D □□-FNS8-AB	1/2 Female NPT	Flange	1/4 Female NPT	Optional
5D □□-FL8-AB	1/2" FITOK	Flange	1/4 Female NPT	Optional

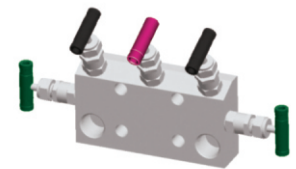
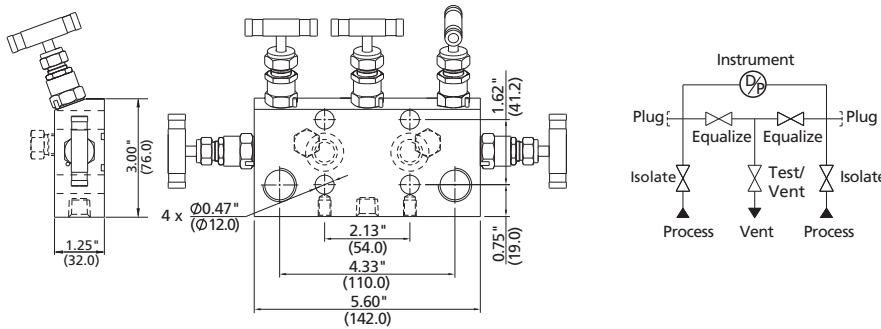

Notes: 1. Every manifold is supplied with two PTFE sealing rings for manifold-to-instrument and four 7/16" UNF x 1.75" high tensile bolts.
2. FL8 connections are obtained by adding an extra CM tube fitting to the FNS8 connections.

Basic Ordering Number	Inlet/Process	Outlet/Instrument	Vent	Test
5D □□-FNS8-VB	1/2 Female NPT	Flange	1/4 Female NPT	Optional

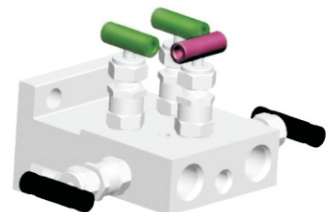
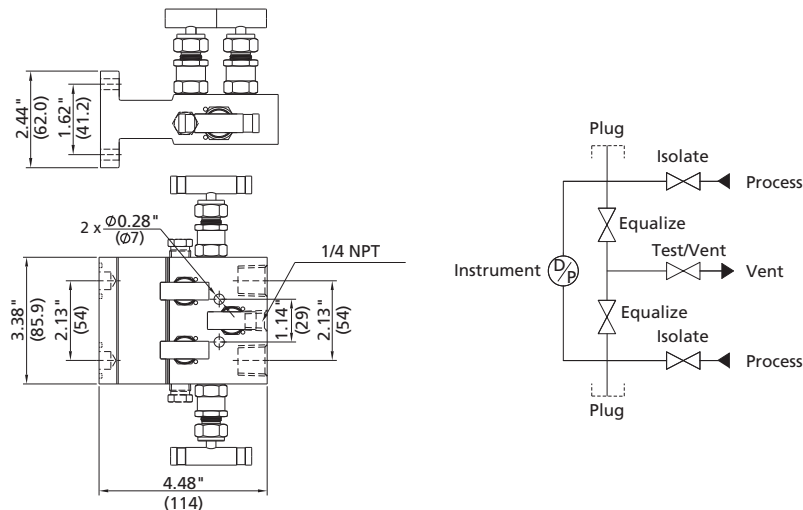

Every manifold is supplied with two PTFE sealing ring for manifold-to-instrument and four 7/16" UNF x 24 mm high tensile bolts.

Basic Ordering Number	Inlet/Process	Outlet/Instrument	Vent	Test
5D□□-F-VB	Flange	Flange	1/4 Female NPT	Optional

Every manifold is supplied with two PTFE sealing ring for manifold-to-instrument and four 7/16" UNF x 24 mm high tensile bolts.

Basic Ordering Number	Inlet/Process	Outlet/Instrument	Test/Vent
5R□□-FNS8-VB	1/2 Female NPT	1/2 Female NPT	1/4 Female NPT

Manifolds

C-18 Gauge Valves and Instrumentation Manifolds

Basic Ordering Number	Inlet/Process	Outlet/Instrument	Vent	Test
5R□□-FNS8-AB	1/2 Female NPT	1/2 Female NPT	1/4 Female NPT	Optional
5R□□-FL8-FNS8-AB	1/2" FITOK	1/2 Female NPT	1/4 Female NPT	Optional

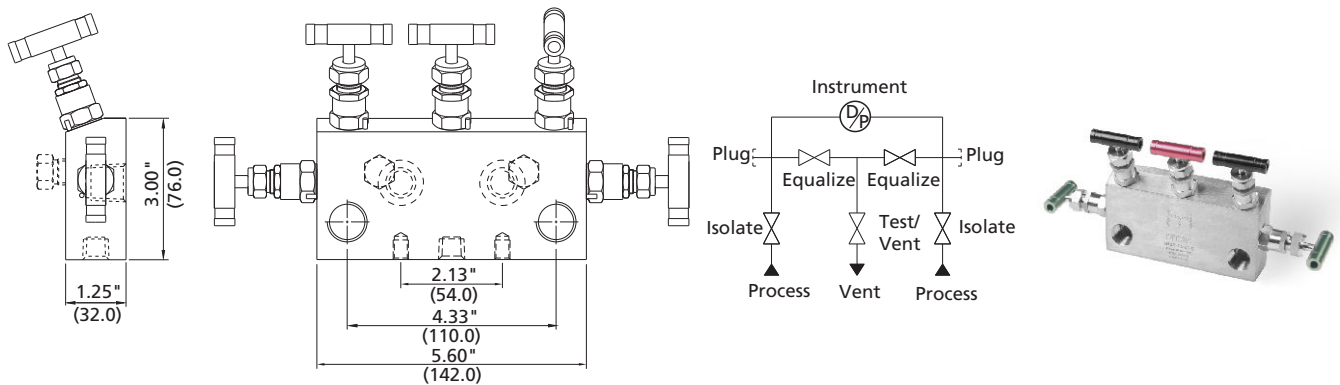

FL8 connections are obtained by adding an extra CM tube fitting to the FNS8 connections.

C Integral Manifolds

C Integral Manifold is specifically designed for the pressure transmitters of Rosemount® coplanar™, including Model 3051C, 3051S, 2024 and 3095. It can be assembled directly to transmitters, eliminating the need for flanges. Each of the following manifolds contains four 7/16" UNF x 2" high tensile bolts.

Basic Ordering Number	Inlet/Process	Outlet/Instrument	Test/Vent
2D□□-FNS8-C	1/2 Female NPT	Flange	1/4 Female NPT
2DH□□-FNS8-C			

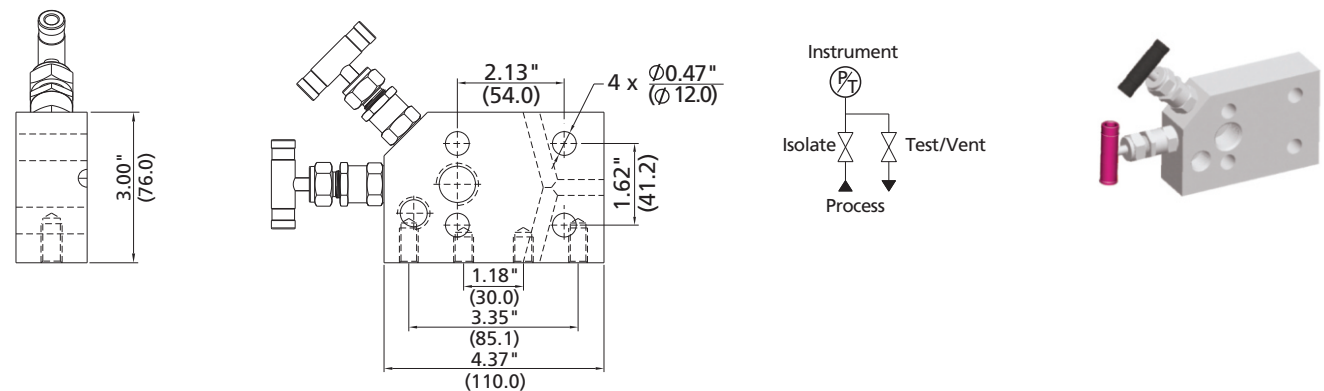

Basic Ordering Number	Inlet/Process	Outlet/Instrument	Test/Vent
3D □ □ -FNS8-C	1/2 Female NPT	Flange	Optional
3DH □ □ -FNS8-C			
3D □ □ -FL8-C	1/2" FITOK	Flange	Optional

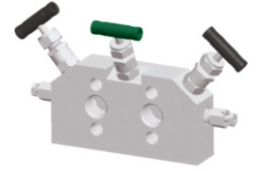
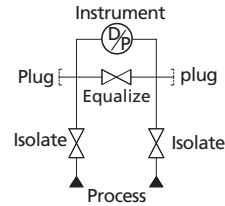
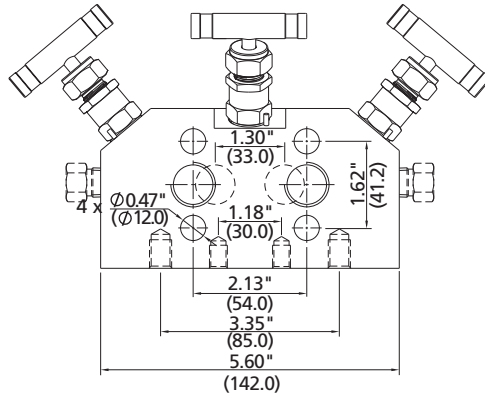
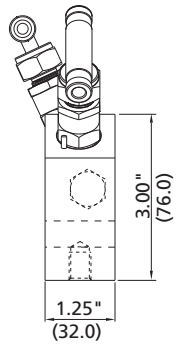

Basic Ordering Number	Inlet/Process	Outlet/Instrument	Test/Vent
5D □ □ -FNS8-C	1/2 Female NPT	Flange	1/4 Female NPT
5DH □ □ -FNS8-C			
5D □ □ -FL8-C	1/2" FITOK	Flange	1/4 Female NPT

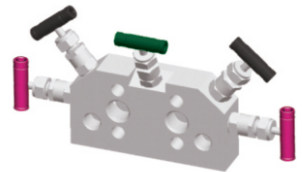
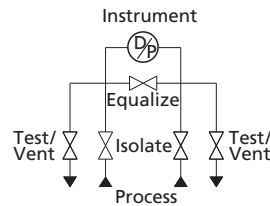
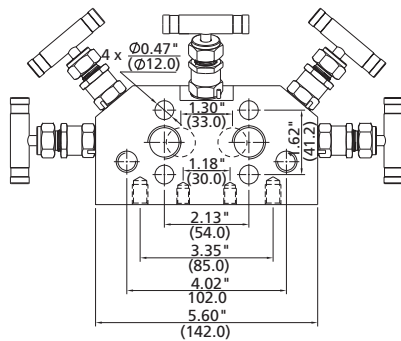
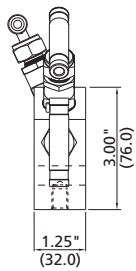

Manifolds

Dimensions shown are for 2DI/3DI/5D Series manifolds. For dimensions of 2DH/3DH/5DH Series manifolds, please contact FITOK Group or our authorized distributors.
 FL8 connections are obtained by adding an extra CM tube fitting to the FNS8 connections.

Ordering Number Description

3DSS - FNS8 - LG - ET - 1M - SF2

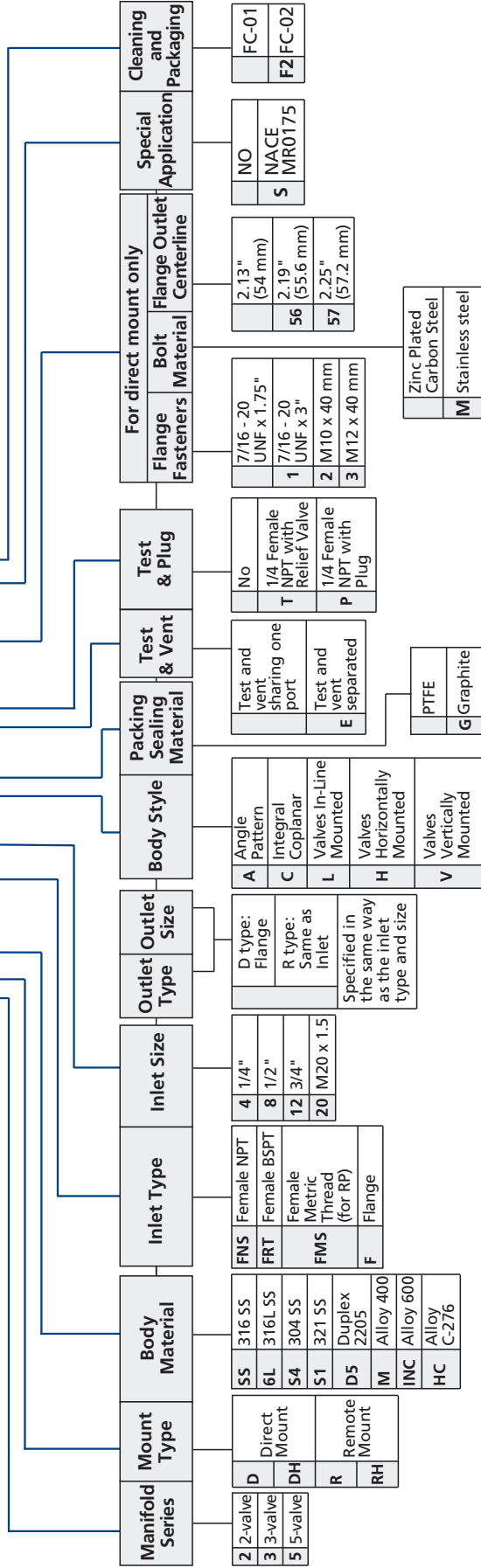

Notes:

- To order 5-valve manifolds with double-equalize function, add B to the Body Style of the manifold ordering number. Example: 5DSS-FNS8-AB
- Plug options are as follows:
 - If option of test and vent sharing one port with plug is needed, add "-P" to the ordering number. Example: 5DSS - FNS8 - AB - P;
 - If option of test and vent separating with a plug to the test port is needed, add "-EP" to the ordering number. Example: 5DSS - FNS8 - AB - EP;
 - If option of test and vent separating with plug for each port is needed, add "-E2P" to the ordering number. Example: 5DSS - FNS8 - AB - E2P.
- The standard center line distance of direct mounting flange outlet of 3-valve manifold and 5-valve manifold is 2.13" (54 mm).
 - Center line distance of 2.188" (55.6 mm) is suitable for range 6 and 7, 1151 series transmitter.
 - Center line distance of 2.250" (57.2 mm) is suitable for range 8, 1151 series transmitter.
- The standard configuration of direct mounting manifold contains PTFE flange seal ring and 7/16-20 UNF X 1.75" high tensile bolts; can be connected with transmitters under main brands, such as EJA, Honeywell, Foxboro 843 dlp, and Rosemount® 151, 2024, 3051H series.
- 7/16-20 UNF x 3" high tensile bolts can be supplied, can be used for coplanar mounting of the Rosemount® 3051C transmitter with process flange and the manifold.
- Cleaning and Packaging:
 - FC-01: Standard cleaning and packaging for general industrial procedures.
 - FC-02: Special cleaning and packaging for wetted system components to ensure compliance with product cleanliness requirement as stated in ASTM G93 Level C.
- "Ordering Number Description" is a reference to understand the combination rules of FITOK product part number. Not all combinations are available.

Accessories

Manifold Bracket Supports

SS-M2P-2BK

1. The integral assembly includes: bracket, U-bolts, bolts, gaskets, nuts
2. Fits with 2R□□-XX-A, 2R□□-XX-L, 2RH□□-XX-A

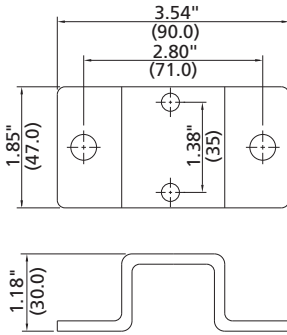

3. SS-M2P-2BK-50 fits with 2R□□-XX-V
4. SS-M2P-2BK-17.5 fits with 3R□□-XX-V
5. SS-M2P-2BK-28.7 fits with 5R□□-XX-VB, 5R□□-XX-V

SS-M2P-6BK

1. The integral assembly includes: bracket, U-bolts, bolts, gaskets, nuts
2. Fits with 2D□□-XX-C, 3D□□-XX-C, 5D□□-XX-C, 2DH□□-XX-C, 3DH□□-XX-C, 5DH□□-XX-C

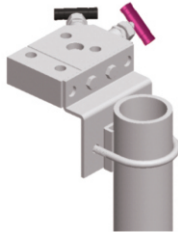
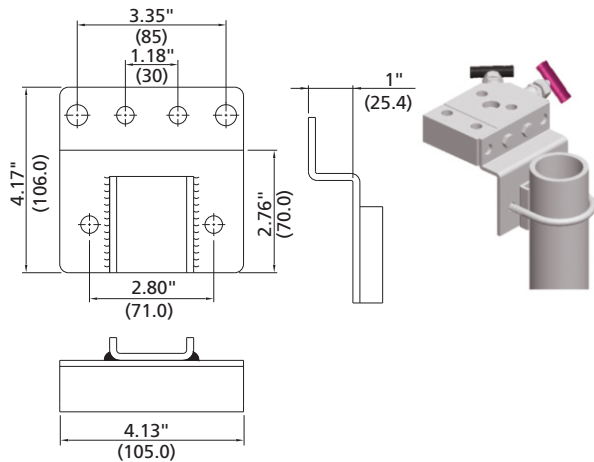

SS-M2P-4BK

1. The bracket support is available for horizontal or vertical installation
2. The integral assembly includes: bracket, U-bolts, bolts, gaskets, nuts
3. Fits with 2D□□-XX-A, 2D□□-XX-L, 3D□□-XX-A, 3D□□-XX-L, 5D□□-XX-A, 5D□□-XX-AB, 5R□□-XX-L, 5R□□-XX-AB, 2DH□□-XX-A, 3DH□□-XX-A, 5DH□□-XX-A, 5RH□□-XX-AB

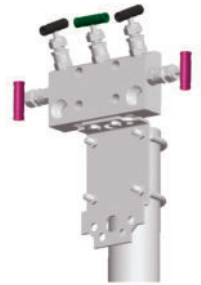
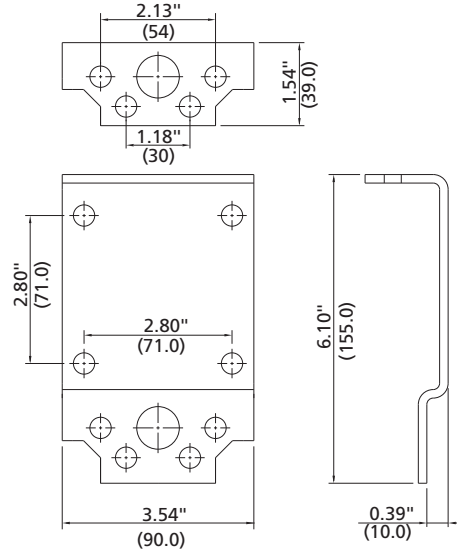

SS-M2P-8BK

1. The bracket support is available for horizontal or vertical installation
2. The integral assembly includes: bracket, U-bolts, bolts, gaskets, nuts
3. Fits with 2D□□-XX-A, 3D□□-XX-A, 3D□□-XX-L, 2D□□-XX-C, 3D□□-XX-C, 5D□□-XX-C

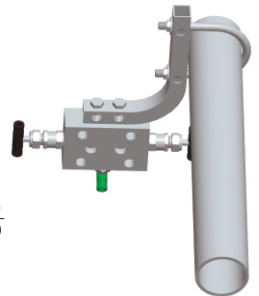
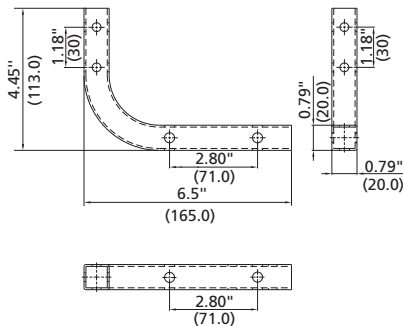

For more installation information regarding other manifolds, please contact FITOK Group or our authorized distributors.

Kidney Flanges and Eccentric Flanges

Features

- ⦿ Working temperature:
 - PTFE: -65°F to 450°F (-54°C to 232°C)
 - Graphite: -65°F to 1200°F (-54°C to 649°C)
- ⦿ Integral forged body
- ⦿ Standard material: A182 F316

Types and Dimensions

Kidney Flanges

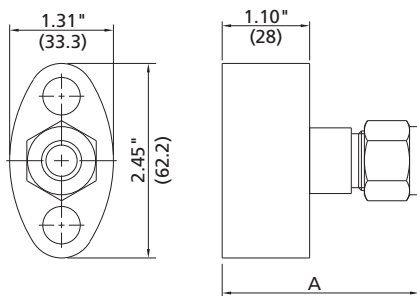

Eccentric Flanges

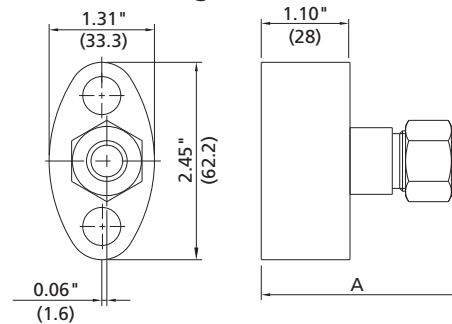

The process connection type of transmitter can be transformed to other connection types.

Ordering Information

Basic Ordering Number	Connection Type and Size	Dimension in. (mm)
		A
SS-KF-FNS4	1/4 Female NPT	1.10 (28)
SS-KF-FNS8	1/2 Female NPT	1.10 (28)
SS-KF-FL8	1/2" FITOK	2.48 (63)
SS-KF-PB8	1/2 PB	2.10 (53.3)

A kidney flange set contains a PTFE flange seal ring and two 7/16 - 20 UNF high tensile bolts.

Ordering Information

Basic Ordering Number	Connection Type and Size	Dimension in. (mm)
		A
SS-EF-FNS4	1/4 Female NPT	1.10 (28)
SS-EF-FNS8	1/2 Female NPT	1.10 (28)
SS-EF-FL8	1/2" FITOK	2.48 (63)
SS-EF-PB8	1/2 PB	2.10 (53.3)

1. Eccentric flange needs to be ordered in whole set.
2. A whole eccentric flange set contains two eccentric flanges, two PTFE flange seal rings and four 7/16 - 20 UNF high tensile bolts.

The Selection of Flange Seal Materials

The standard flange seal material is PTFE, graphite is an option. To order graphite flange seal material, add "- G" as a suffix.

Various Combinations of Eccentric Flange Set

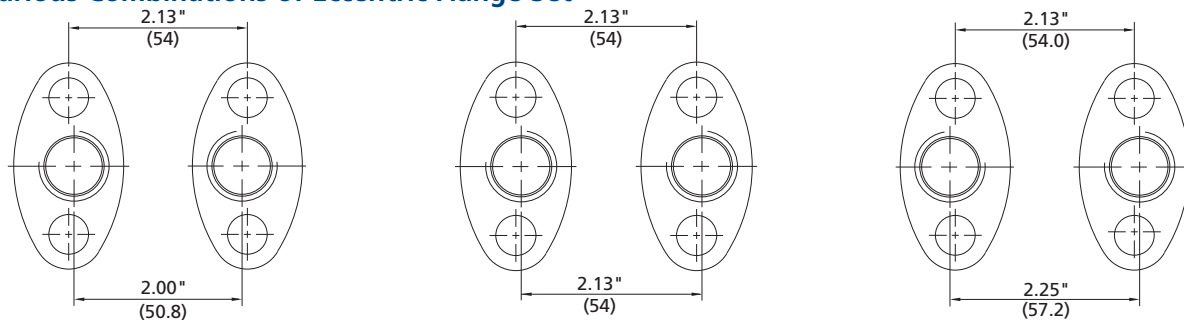

Combinations of eccentric flange set can give different center line distances of 2.0" (50.8 mm), 2.13" (54 mm) and 2.25" (57 mm).

Bleed Valves

- ⦿ RB Series RBSS-NS4 Bleed Valve is used as standard test/vent valve.
- ⦿ For more information, refer to FITOK Bleed Valve RB Series.

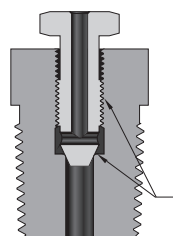

Chrome-plated Stem and Tip Extend Cycle Life.

Calibration Fittings

- ⦿ The calibration fittings can be connected directly with the bleed port of transmitter so that the calibration process can be simplified.
- ⦿ For more information, refer to FITOK Calibration Fittings.

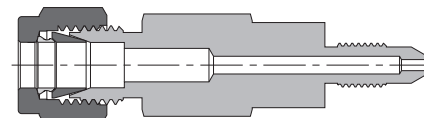

Block and Bleed Valves

BB, DB, SB and DBB Series



Contents

BB Series: Single Block and Bleed Valves	C-28
---	-------------

DB Series: Double Block Valves	C-34
---------------------------------------	-------------

SB Series: Single Block Valves	C-35
---------------------------------------	-------------

DBB Series: Double Block and Bleed Valves	C-36
--	-------------

Features

- ⦿ Pressure ratings in accordance with ASME B16.34
- ⦿ Color coded handles indicate functions
- ⦿ Every valve is factory tested in accordance with API 598 or EN 12266
- ⦿ Flange connections comply with ASME B16.5, EN 1092-1 compliance is also available upon request
- ⦿ Bleed port equipped with plug
- ⦿ Weight, space and cost saving over traditional design

Ball Valve Model

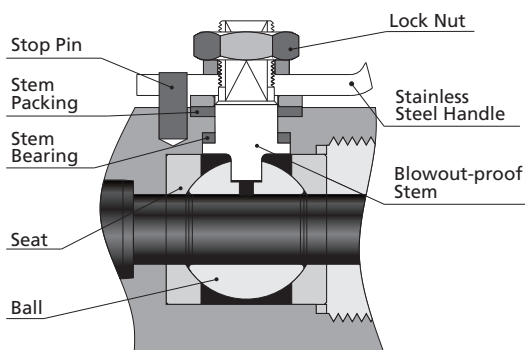

Features

- ⦿ Pressure rating up to: Class 2500
- ⦿ Working temperature : -65°F to 450°F (-54°C to 232°C)
- ⦿ Actuate at quarter-turn
- ⦿ Directional stem flats show open or closed position
- ⦿ Bottom-loaded stem prevents stem blowout and enhances system safety
- ⦿ High-strength stem bearing provides smooth actuation and eliminates galling between valve stem and body
- ⦿ It may be required to adjust the packing during the service life of the valve
- ⦿ FITOK ball valves are designed to be operated in a fully open or fully closed position

Needle Type Valve Model

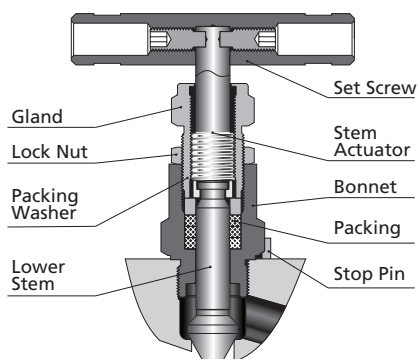

Features

- ⦿ Pressure rating up to: Class 4500
- ⦿ Working temperatures are as follows:
PTFE: -65°F to 450°F (-54°C to 232°C)
Graphite: -65°F to 1200°F (-54°C to 649°C)
- ⦿ Two-piece stem design: Upper stem threads cold rolled and hardened lower stem for high strength and smooth operation
- ⦿ Upper stem thread lubricant is isolated from system fluid
- ⦿ Linear instead of rotary motion of the rising, non-rotating stem minimizes packing abrasion and reduces the friction between the seat and the tip
- ⦿ Stem back seating seals in fully open position
- ⦿ Double lock-pins enable steady and durable fastening of the handle

OS&Y Needle Type Valve Model

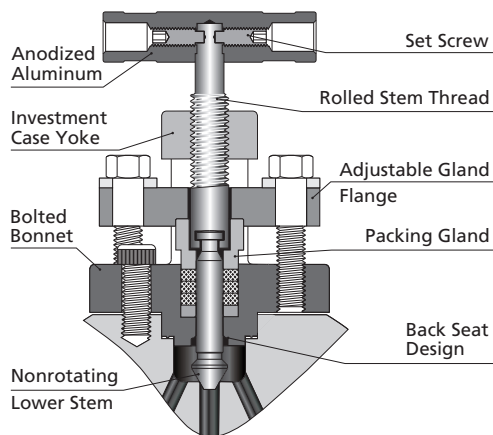

Features

- ⦿ Pressure rating up to: Class 2500
- ⦿ Working temperatures are as follows:
PTFE: -65°F to 450°F (-54°C to 232°C)
Graphite: -65°F to 1200°F (-54°C to 649°C)
- ⦿ Two-piece stem design: Upper stem threads cold rolled and hardened lower stem for high strength and smooth operation
- ⦿ Upper stem thread lubricant is isolated from system fluid
- ⦿ Linear instead of rotary motion of the rising, non-rotating stem minimizes packing abrasion and reduces the friction between the seat and the tip
- ⦿ Bolted bonnet enhances strength and reliability
- ⦿ Back seat design provides secondary stem sealing and prevents stem blowout
- ⦿ Adjustable gland flange allows easy access to the packing gland and packing adjustment for an effective stem seal
- ⦿ Investment case yoke is formed by precision casting which enhances strength and perfect stem alignment
- ⦿ Two handle pins make the handle fixed firmly and lastingly

Handle colors indicate functions:

Needle and OS&Y valves:

BLACK = Isolate/Block **RED** = Vent/Bleed

Ball valves:

YELLOW = Isolate/Block **RED** = Vent/Bleed

Standard Materials of Construction

Component	Body Material					
	Stainless Steel		Carbon Steel	Duplex Stainless Steel		
	Material Grade/Specification					
Body/End Connector	316 SS, 316L SS /A182	316 SS, 316L SS /A479	A105, LF2/A350	F51/A182	S31803/A479	
Ball Valve	Ball				S31803/A479	
	Stem	316 SS, 316L SS/A479				
	Washer					
	Stop Block	304 SS/A240				
	Seat	PEEK/PCTFE				
	Needle Type Globe Valve	Stem Tip				S31803/A479
Stem		316 SS, 316L SS/A479				
Bonnet						
OS&Y Needle Type Globe Valve	Stem Tip				S31803/A479	
	Stem	316 SS, 316L SS/A479				
	Packing Gland					
	Yoke	F316 SS/A182, A105 or LF2/A350				

Stainless steel is standard material, others are available upon request.

Flange Connection

Pressure - Temperature Rating

FITOK Block and Bleed Valves offer a variety of sizes and pressure ratings of the flange in accordance with ASME B16.5 Specifications. Ratings are taken from ASME B16.5, Table 2-2.2 and Table F2-2.2. The rating data are based on stainless steel F316/A182.

Temp. °C	ASME Ratings					
	150	300	600	900	1500	2500
	Working Pressure, bar					
-29 to 38	19.0	49.6	99.3	148.9	248.2	413.7
50	18.4	48.1	96.2	144.3	240.6	400.9
100	16.2	42.2	84.4	126.6	211.0	351.6
150	14.8	38.5	77.0	115.5	192.5	320.8
200	13.7	35.7	71.3	107.0	178.3	297.2
250	12.1	33.4	66.8	100.1	166.9	278.1
300	10.2	31.6	63.2	94.9	158.1	263.5
325	9.3	30.9	61.8	92.7	154.4	257.4
350	8.4	30.3	60.7	91.0	151.6	252.7
375	7.4	29.9	59.8	89.6	149.4	249.0
400	6.5	29.4	58.9	88.3	147.2	245.3
425	5.5	29.1	58.3	87.4	145.7	242.9
450	4.6	28.8	57.7	86.5	144.2	240.4

Temp. °F	ASME Ratings					
	150	300	600	900	1500	2500
	Working Pressure, psig					
-20 to 100	275	720	1440	2160	3600	6000
200	235	620	1240	1860	3095	5160
300	215	560	1120	1680	2795	4660
400	195	515	1025	1540	2570	4280
500	170	480	955	1435	2390	3980
600	140	450	900	1355	2255	3760
650	125	440	885	1325	2210	3680
700	110	435	870	1305	2170	3620
750	95	425	855	1280	2135	3560
800	80	420	845	1265	2110	3520
850	65	420	835	1255	2090	3480

Sour Gas Service/NACE Compliant

Process interface valves for sour gas service are available. Materials are selected in accordance with NACE MR0175/ISO 15156. Contact FITOK Group or our authorized distributors if you have any request.

BB Series: Single Block and Bleed Valves

Instrument Single Block and Bleed Valves

Features

- ⊙ Threaded or one-piece forged body
- ⊙ Orifice (all-ball-valve configuration, ball-and-needle-valve configuration) : Ball 3/8 in. (9.5 mm), Needle 0.16 in. (4 mm); Orifice (all-needle-valve configuration) : 0.16 in. (4 mm) is standard, 0.25 in. (6.4 mm) and 0.38 in. (9.5 mm) are available upon request.

Block: ball Bleed: ball (configuration: BB)

Basic Ordering Number	Inlet/Process	Outlet/Instrument	Vent/Bleed
BB□□-BB-FNS8-V4-C	1/2 female NPT	1/2 female NPT	1/4 female NPT
BB□□-BB-FNS8-V4-CG	1/2 female NPT	1/2 female NPT	1/4 female NPT

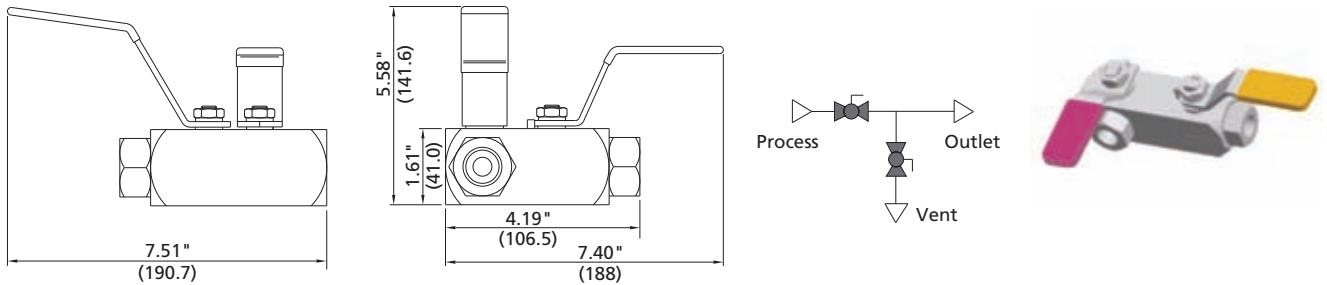

Block: ball Bleed: needle (configuration: BN)

Basic Ordering Number	Inlet/Process	Outlet/Instrument	Vent/Bleed
BB□□-BN-FNS8-V4-V	1/2 female NPT	1/2 female NPT	1/4 female NPT
BB□□-BN-FNS8-V4-VG	1/2 female NPT	1/2 female NPT	1/4 female NPT
BB□□-BN-FNS8-NS8-V4-V	1/2 female NPT	1/2 male NPT	1/4 female NPT
BB□□-BN-FNS8-NS8-V4-VG	1/2 female NPT	1/2 male NPT	1/4 female NPT

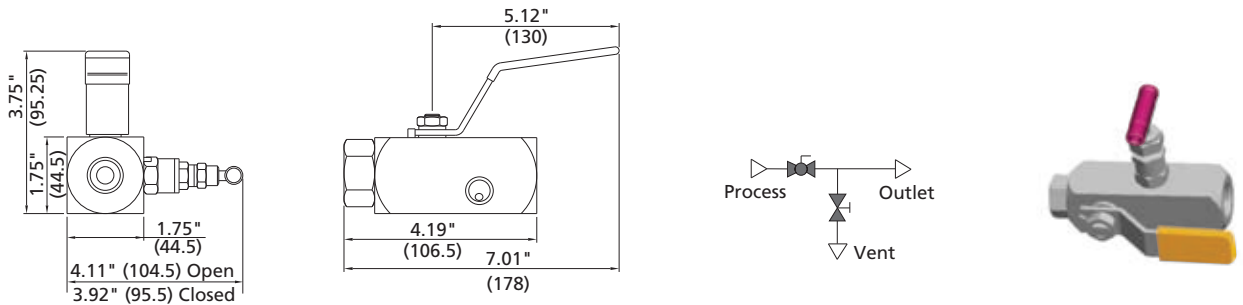

Manifolds

Block: needle Bleed: needle (configuration: NN)

Basic Ordering Number	Inlet/Process	Outlet/Instrument	Vent/Bleed
BB□□-NN-NS8-FNS8-V4-H	1/2 male NPT	1/2 female NPT	1/4 female NPT
BB□□-NN-NS12-FNS8-V4-HG	3/4 male NPT	1/2 female NPT	1/4 female NPT

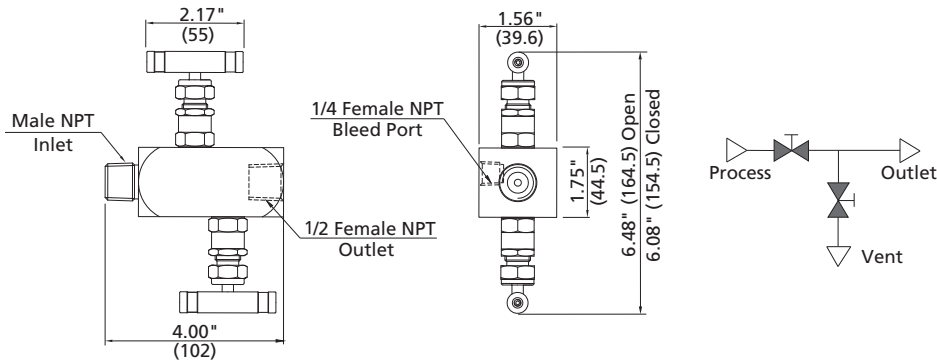

Flange Single Block and Bleed Valves

Features

- ⦿ Threaded or one-piece forged body
- ⦿ Piping and instrument valves in one body
- ⦿ 1/2 female NPT standard outlet
- ⦿ Orifice (ball-and-needle-valve configuration) : Ball 3/8 in. (9.5 mm), Needle 0.16 in. (4 mm);
Orifice (all-ball-valve configuration) : 3/8 in. (9.5 mm)

Block: ball Bleed: needle (configuration: BN)

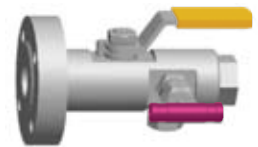
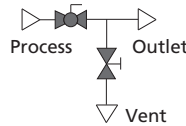
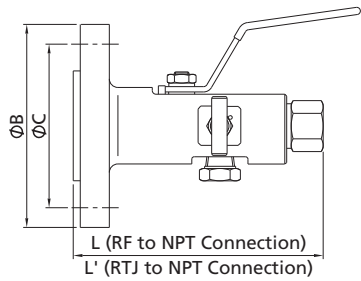

Block: ball Bleed: needle (configuration: BN)

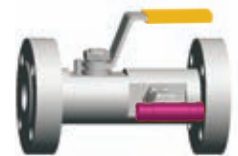
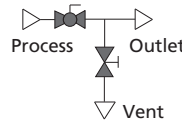
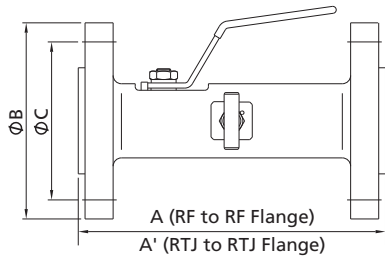

C-30 Block and Bleed Valves

Block: ball Bleed: ball (configuration: BB)

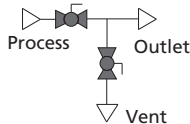
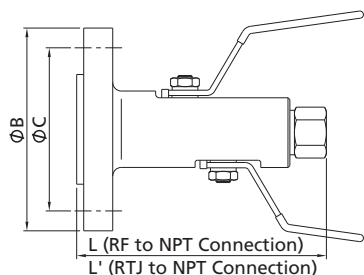

Block: ball Bleed: ball (configuration: BB)

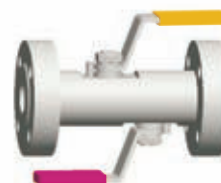
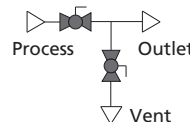
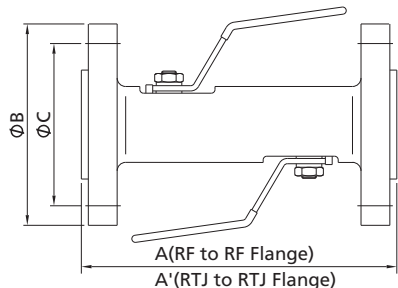

Flange Size	Bore Size in. (mm)	ASME Class	L in. (mm)	L' in. (mm)	A in. (mm)	A' in. (mm)	ØB in. (mm)	ØC in. (mm)		
NPS 1/2 (DN 15)	3/8 (9.5)	150	4.88 (124.0)	—	6.41 (162.8)	—	3.54 (90)	2.37 (60.3)		
		300		4.88 (124.0)	6.81 (173.0)	6.81 (173.0)	3.74 (95)	2.63 (66.7)		
		600	5.67 (144.0)	5.67 (144.0)	7.99 (202.9)	7.99 (202.9)	4.72 (120)	3.25 (82.6)		
		900/1500					5.31 (135)	3.50 (88.9)		
		2500					5.31 (135)	3.50 (88.9)		
NPS 3/4 (DN 20)	3/8 (9.5)	150	4.88 (124.0)	—	6.41 (162.8)	—	3.94 (100)	2.75 (69.9)		
		300		4.88 (124.0)	6.81 (173.0)	6.81 (173.0)	4.53 (115)	3.25 (82.6)		
		600	5.67 (144.0)	5.67 (144.0)	7.99 (202.9)	7.99 (202.9)	5.12 (130)	3.50 (88.9)		
		900/1500					5.51 (140)	3.75 (95.2)		
		2500					5.51 (140)	3.75 (95.2)		
NPS 1 (DN 25)	3/8 (9.5)	150	4.88 (124.0)	4.88 (124.0)	6.41 (162.8)	6.61 (167.9)	4.33 (110)	3.13 (79.4)		
		300			7.00 (177.8)	7.00 (177.8)	4.92 (125)	3.50 (88.9)		
		600	5.98 (151.9)	5.98 (151.9)	10.30 (261.6)	10.30 (261.6)	5.91 (150)	4.00 (101.6)		
		900/1500					10.70 (271.8)	10.70 (271.8)	6.30 (160)	4.25 (108.0)
		2500					10.70 (271.8)	10.70 (271.8)	6.30 (160)	4.25 (108.0)
NPS 1 1/2 (DN 40)	3/8 (9.5)	150	5.98 (151.9)	5.98 (151.9)	8.90 (226.1)	9.49 (241.0)	4.92 (125)	3.87 (98.4)		
		300			9.89 (251.2)	9.89 (251.2)	6.10 (155)	4.50 (114.3)		
		600	6.61 (167.9)	6.61 (167.9)	11.50 (292.1)	11.50 (292.1)	7.09 (180)	4.87 (123.8)		
		900/1500					12.40 (315.0)	12.40 (315.0)	8.07 (205)	5.75 (146)
		2500					12.40 (315.0)	12.40 (315.0)	8.07 (205)	5.75 (146)
NPS 2 (DN 50)	3/8 (9.5)	150	5.98 (151.9)	5.98 (151.9)	9.09 (230.9)	9.49 (241.0)	5.91 (150)	4.75 (120.7)		
		300			10.10 (256.5)	10.30 (261.6)	6.50 (165)	5.00 (127.0)		
		600	6.61 (167.9)	6.61 (167.9)	12.00 (304.8)	12.00 (304.8)	8.46 (215)	6.50 (165.1)		
		900/1500					13.60 (345.4)	13.60 (345.4)	9.25 (235)	6.75 (171.4)
		2500					13.60 (345.4)	13.60 (345.4)	9.25 (235)	6.75 (171.4)

Dimensions are for reference only and are subject to change.

Root Single Block and Bleed Valves

Features

- ⦿ Directly-mounted root valves available to the vessel or process pipe
- ⦿ Weld inlet connection sizes from NPS 1/2 to NPS 2
- ⦿ 1/2 female NPT standard vent with plug
- ⦿ 1/2 female NPT standard outlet
- ⦿ Orifice (ball-and-needle-valve configuration) : Ball 3/8 in. (9.5 mm), Needle 0.16 in. (4 mm);
Orifice (all-needle-valve configuration) : 0.16 in. (4 mm) is standard, 0.25 in. (6.4 mm) and 0.38 in. (9.5 mm) are available upon request.

Block: ball Bleed: needle (configuration: BN)

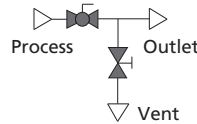
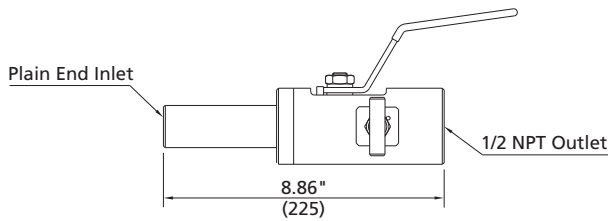

Block: ball Bleed: OS&Y (configuration: BO)

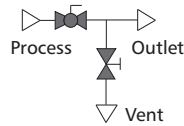
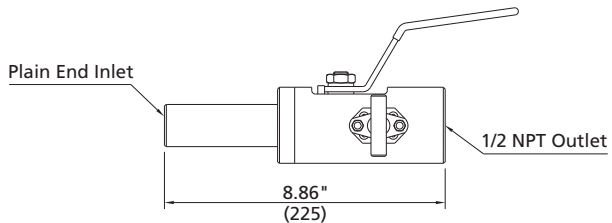

Block: OS&Y Bleed: needle (configuration: ON)

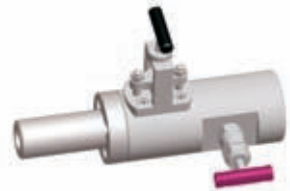
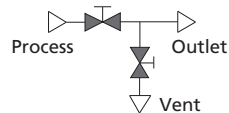
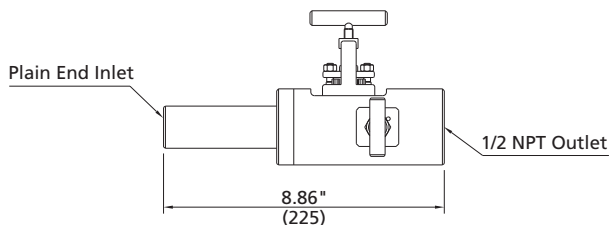

Block: needle Bleed: needle (configuration: NN)

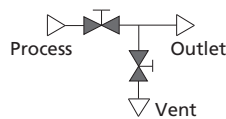
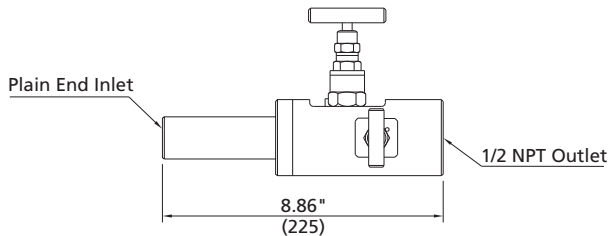

Dimensions are for reference only and are subject to change.

Manifolds

Monoflange Single Block and Bleed Valves

Features

- Piping and instrument valves in one body
- 1/4 female NPT standard vent with plug
- 1/2 female NPT standard outlet
- Orifice: 0.16 in. (4 mm) is standard, 0.25 in. (6.4 mm) and 0.38 in. (9.5 mm) are available for some flange sizes

Block: OS&Y Bleed: needle (configuration: ON)

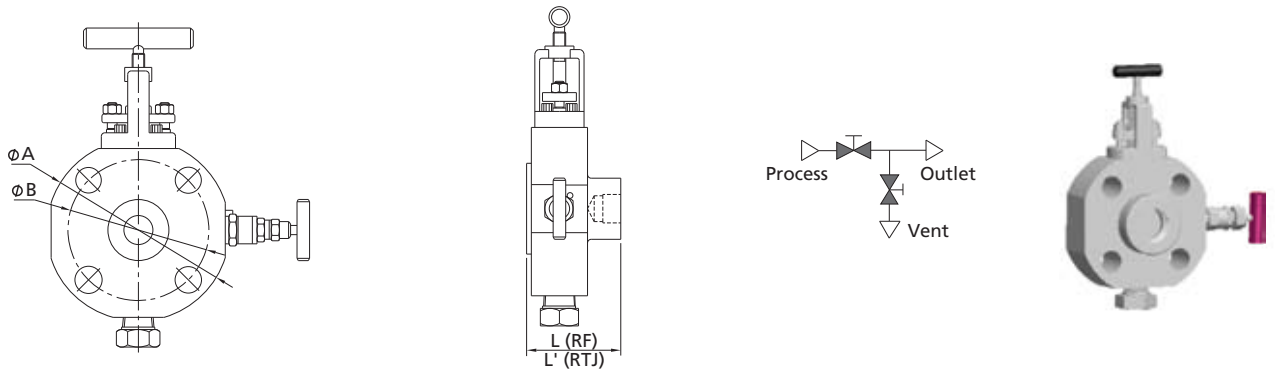

Block: needle Bleed: needle (configuration: NN)

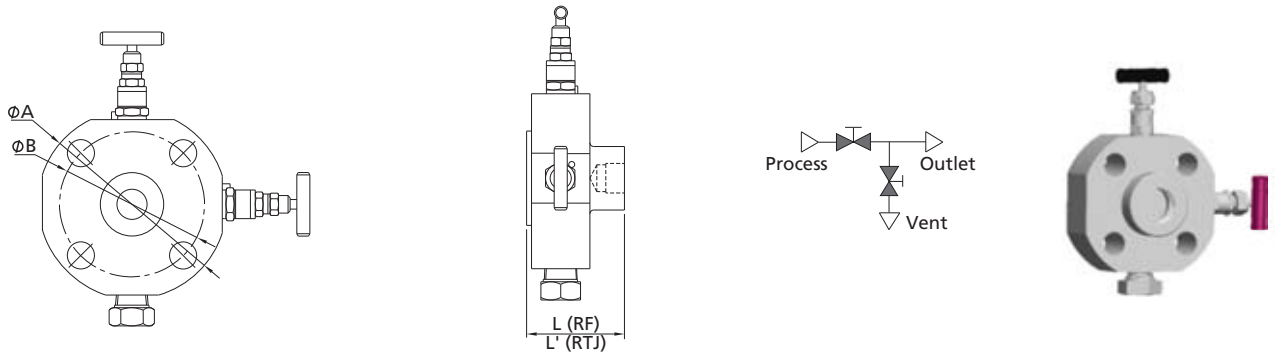

Block: OS&Y Bleed: needle (configuration: ON, Two Vents)

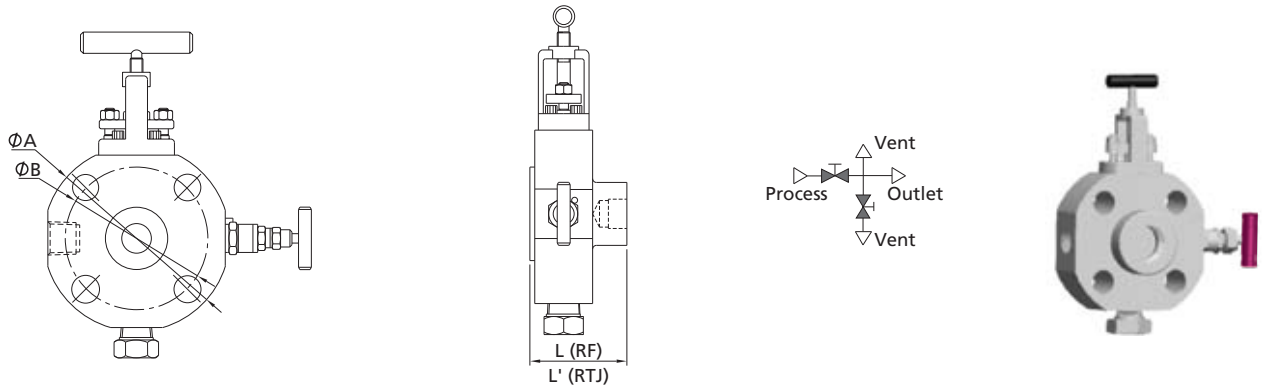

Manifolds

Block: needle Bleed: needle (configuration: NN, Two Vents)

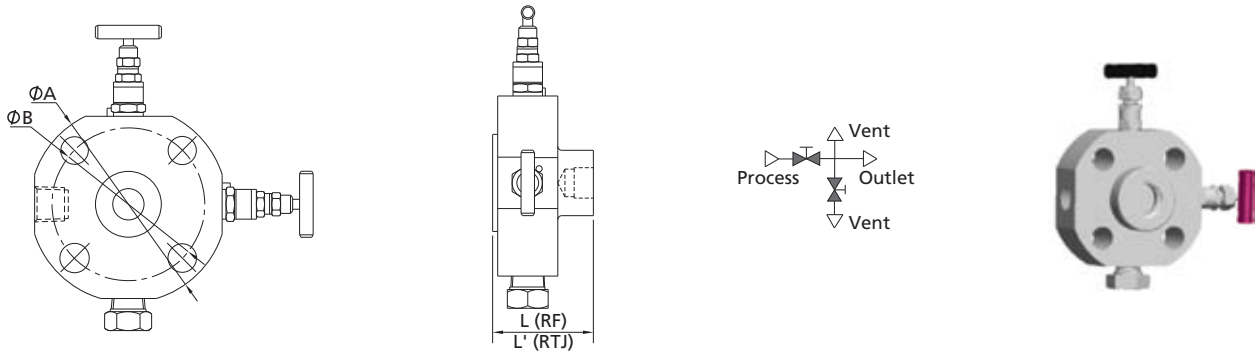

Flange Size	Bore Size in. (mm)	ASME Class	L in. (mm)	L' in. (mm)	Ø A in. (mm)	Ø B in. (mm)
NPS 1/2 (DN 15)	0.16 (4.0)	150	2.03 (51.6)	—	3.54 (90)	2.37 (60.3)
		300		2.03 (51.6)	3.74 (95)	2.63 (66.7)
		600			4.72 (120)	3.25 (82.6)
		900/1500			5.31 (135)	3.50 (88.9)
		2500			5.91 (150)	4.00 (101.6)
NPS 3/4 (DN 20)		150	2.03 (51.6)	—	3.94 (100)	2.75 (69.9)
		300		2.03 (51.6)	4.53 (115)	3.25 (82.6)
		600			5.12 (130)	3.50 (88.9)
		900/1500			5.51 (140)	3.75 (95.2)
		2500	2.11 (53.5)	2.11 (53.5)	5.91 (150)	4.00 (101.6)
NPS 1 (DN 25)	150	2.03 (51.6)	2.03 (51.6)	4.33 (110)	3.13 (79.4)	
	300			4.92 (125)	3.50 (88.9)	
	600			5.91 (150)	4.00 (101.6)	
	900/1500	2.11 (53.5)	2.11 (53.5)	6.30 (160)	4.25 (108.0)	
	2500	2.11 (53.5)	2.11 (53.5)	6.30 (160)	4.25 (108.0)	
NPS 1 1/2 (DN 40)	150	2.03 (51.6)	2.03 (51.6)	4.92 (125)	3.87 (98.4)	
	300			6.10 (155)	4.50 (114.3)	
	600	2.11 (53.5)	2.11 (53.5)	6.10 (155)	4.50 (114.3)	
	900/1500	2.19 (55.5)	2.19 (55.5)	7.09 (180)	4.87 (123.8)	
	2500	2.67 (67.9)	2.67 (67.9)	8.07 (205)	5.75 (146)	
NPS 2 (DN 50)	150	2.11 (53.5)	2.11 (53.5)	5.91 (150)	4.75 (120.7)	
	300			6.50 (165)	5.00 (127.0)	
	600	2.19 (55.5)	2.19 (55.5)	6.50 (165)	5.00 (127.0)	
	900/1500	2.42 (61.5)	2.42 (61.5)	8.49 (215)	6.50 (165.1)	
	2500	2.88 (73.4)	2.88 (73.4)	9.25 (235)	6.75 (171.4)	

Dimensions are for reference only and are subject to change.

DB Series: Double Block Valves

Monoflange Double Block Valves

Features

- Piping and instrument valves in one body
- 1/2 female NPT standard outlet
- Orifice: 0.16 in. (4 mm) is standard, 0.25 in. (6.4 mm) and 0.38 in. (9.5 mm) are available for some flange sizes

Primary: OS&Y Secondary: needle (configuration: ON)

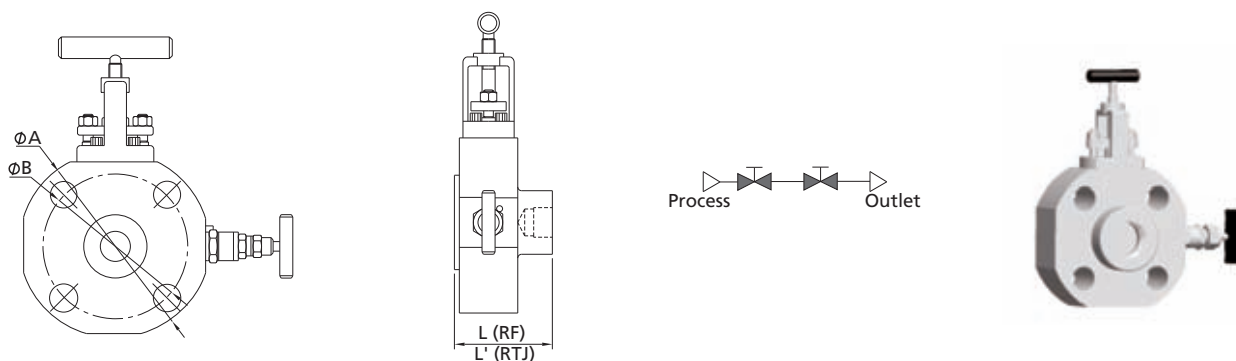

Primary: needle Secondary: needle (configuration: NN)

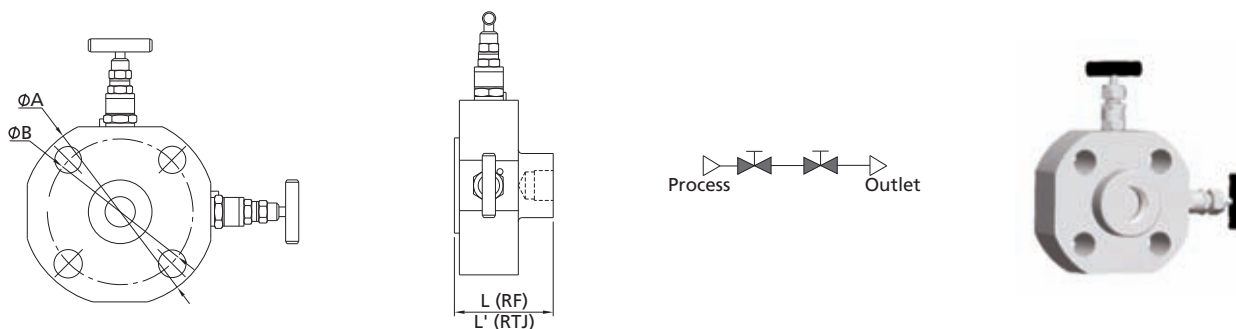

Dimensions are the same as the monoflange single block & bleed valves

Manifolds

SB Series: Single Block Valves

Monoflange Single Block Valves

Features

- Piping and instrument valves in one body
- 1/2 female NPT standard outlet
- Orifice: 0.16 in. (4 mm) is standard, 0.25 in. (6.4 mm) and 0.38 in. (9.5 mm) are available for some flange sizes

Block: OS&Y (O)

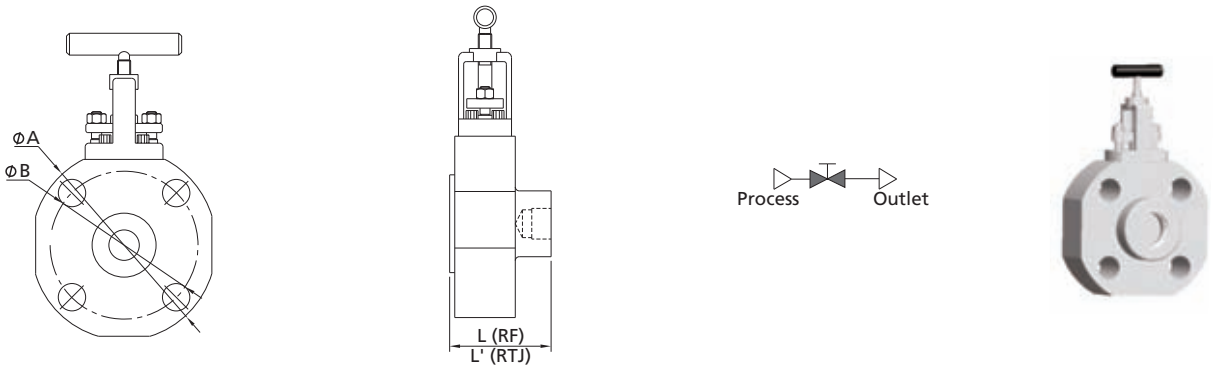

Block: needle (N)

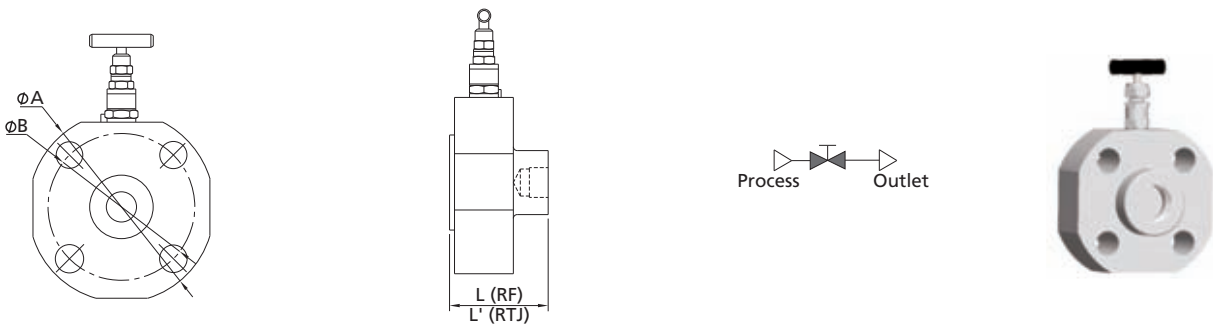

Dimensions are the same as the Monoflange single block & bleed valves

DBB Series: Double Block and Bleed Valves

Instrument Double Block and Bleed Valves

Features

- ⊙ Threaded or one-piece forged body
- ⊙ Optional port sizes and thread forms available
- ⊙ Orifice (all-ball-valve configuration, ball-and-needle-valve configuration) : Ball 3/8 in. (9.5 mm), Needle 0.16 in. (4 mm); Orifice (all-needle-valve configuration) : 0.16 in. (4 mm) is standard, 0.25 in. (6.4 mm) and 0.38 in. (9.5 mm) are available upon request

Primary: ball Secondary: needle Bleed: needle (configuration: BNN)

Basic Ordering Number	Inlet/Process	Outlet/Instrument	Vent/Bleed
DBB□□-BNN-FNS8-V4-V	1/2 female NPT	1/2 female NPT	1/4 female NPT
DBB□□-BNN-FNS8-V4-VG	1/2 female NPT	1/2 female NPT	1/4 female NPT

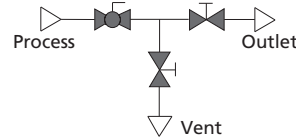
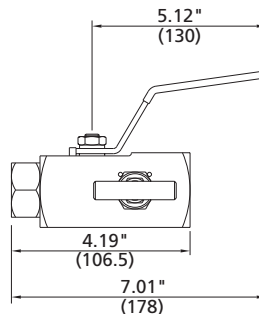
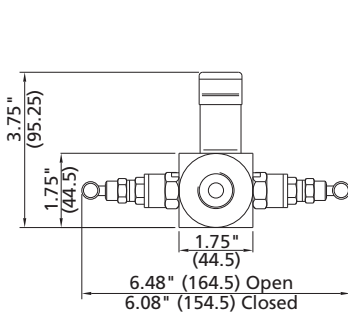

Primary: ball Secondary: ball Bleed: needle (configuration: BBN)

Basic Ordering Number	Inlet/Process	Outlet/Instrument	Vent/Bleed
DBB□□-BBN-FNS8-V4-V	1/2 female NPT	1/2 female NPT	1/4 female NPT
DBB□□-BBN-FNS8-V4-VG	1/2 female NPT	1/2 female NPT	1/4 female NPT

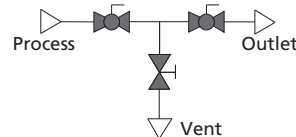
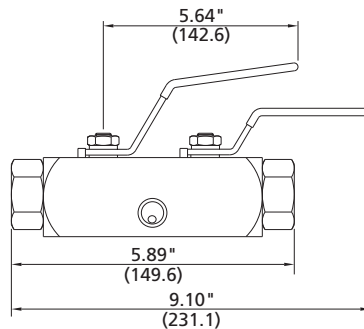
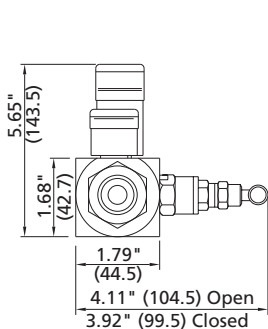

Primary: ball Secondary: ball Bleed: ball (configuration: BBB)

Basic Ordering Number	Inlet/Process	Outlet/Instrument	Vent/Bleed
DBB□□-BBB-FNS8-V4-C	1/2 female NPT	1/2 female NPT	1/4 female NPT
DBB□□-BBB-FNS8-V4-CG	1/2 female NPT	1/2 female NPT	1/4 female NPT

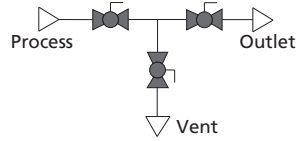
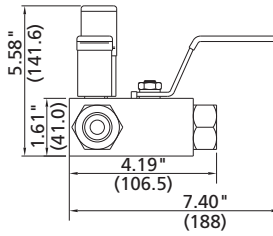
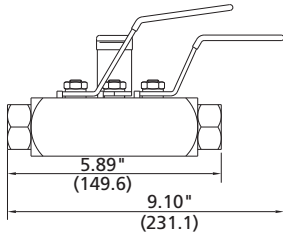

Primary: ball Secondary: ball Bleed: ball (configuration: BBB)

Basic Ordering Number	Inlet/Process	Outlet/Instrument	Vent/Bleed
DBB□□-BBB-FNS8-V4-L	1/2 female NPT	1/2 female NPT	1/4 female NPT
DBB□□-BBB-FNS8-V4-LG	1/2 female NPT	1/2 female NPT	1/4 female NPT

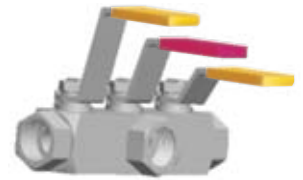
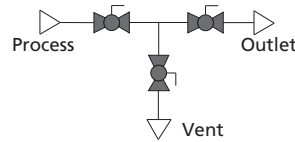
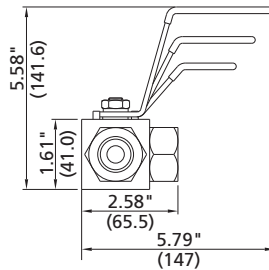
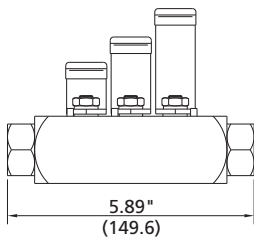

Primary: needle Secondary: needle Bleed: needle (configuration: NNN)

Basic Ordering Number	Inlet/Process	Outlet/Instrument	Vent/Bleed
DBB□□-NNN-NS8-FNS8-V4-V	1/2 male NPT	1/2 female NPT	1/4 female NPT
DBB□□-NNN-NS12-FNS8-V4-VG	3/4 male NPT	1/2 female NPT	1/4 female NPT

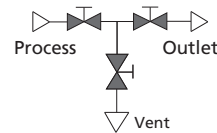
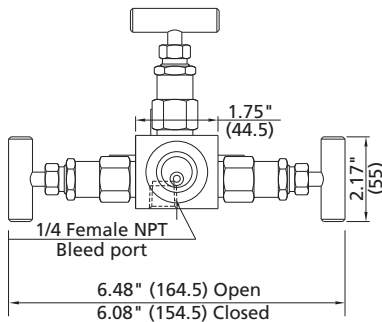
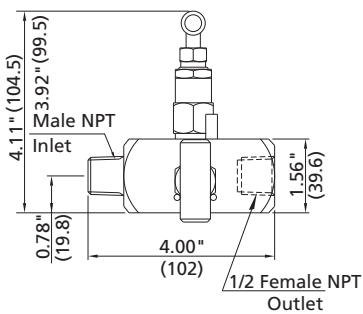

Flange Double Block and Bleed Valves

Features

- ⦿ One piece forged body minimizes potential leak paths
- ⦿ Piping and instrument valves in one body
- ⦿ 1/2 female NPT standard outlet
- ⦿ Orifice (ball-and-needle-valve configuration) : Ball 3/8 in. (9.5 mm), Needle 0.16 in. (4 mm);
Orifice (all-needle-valve configuration) : 0.38 in. (9.5 mm)

Primary: ball Secondary: ball Bleed: needle (configuration: BBN)

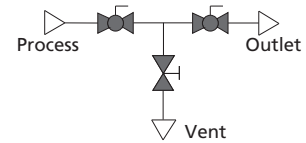
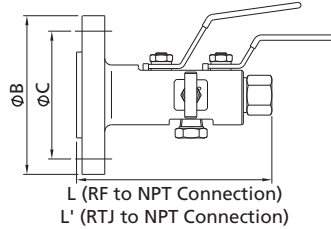
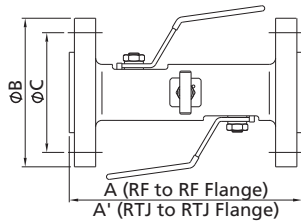

Flange Size	Bore Size in. (mm)	ASME Class	L in. (mm)	L' in. (mm)	A in. (mm)	A' in. (mm)	ØB in. (mm)	ØC in. (mm)
NPS 1/2 (DN 15)	3/8 (9.5)	150	5.91 (150.1)	—	6.41 (162.8)	—	3.54 (90)	2.37 (60.3)
		300		5.91 (150.1)	6.81 (173.0)	6.81 (173.0)	3.74 (95)	2.63 (66.7)
		600	6.69 (170.0)	6.69 (170.0)	7.99 (202.9)	7.99 (202.9)	4.72 (120)	3.25 (82.6)
		900/1500					5.31 (135)	3.50 (88.9)
		2500					5.51 (140)	3.75 (95.2)
NPS 3/4 (DN 20)	3/8 (9.5)	150	5.91 (150.1)	—	6.41 (162.8)	—	3.94 (100)	2.75 (69.9)
		300		5.91 (150.1)	6.81 (173.0)	6.81 (173.0)	4.53 (115)	3.25 (82.6)
		600	6.69 (170.0)	6.69 (170.0)	7.99 (202.9)	7.99 (202.9)	5.12 (130)	3.50 (88.9)
		900/1500					5.51 (140)	3.75 (95.2)
		2500					5.91 (150.1)	5.91 (150.1)
NPS 1 (DN 25)	3/8 (9.5)	300	7.00 (177.8)	7.00 (177.8)	7.00 (177.8)	7.00 (177.8)	4.92 (125)	3.50 (88.9)
		600			10.30 (261.6)	10.30 (261.6)	5.91 (150)	4.00 (101.6)
		900/1500			10.70 (271.8)	10.70 (271.8)	6.30 (160)	4.25 (108.0)
		2500	8.90 (226.1)	9.49 (241.0)	4.92 (125)	3.87 (98.4)		
		NPS 1 1/2 (DN 40)	3/8 (9.5)	150	7.64 (194.1)	7.64 (194.1)	8.90 (226.1)	9.49 (241.0)
300	9.89 (251.2)			9.89 (251.2)			6.10 (155)	4.50 (114.3)
600	11.50 (292.1)			11.50 (292.1)			7.09 (180)	4.87 (123.8)
900/1500	12.40 (315.0)			12.40 (315.0)	8.07 (205)	5.75 (146)		
2500	9.09 (230.9)			9.49 (241.0)	5.91 (150)	4.75 (120.7)		
NPS 2 (DN 50)	3/8 (9.5)	150	7.00 (177.8)	7.00 (177.8)	10.10 (256.5)	10.30 (261.6)	6.50 (165)	5.00 (127.0)
		300			12.00 (304.8)	12.00 (304.8)	8.46 (215)	6.50 (165.1)
		600			13.60 (345.4)	13.60 (345.4)	9.25 (235)	6.75 (171.4)
		900/1500	7.64 (194.1)	7.64 (194.1)	12.00 (304.8)	12.00 (304.8)	8.46 (215)	6.50 (165.1)
		2500	8.03 (204.0)	8.03 (204.0)	13.60 (345.4)	13.60 (345.4)	9.25 (235)	6.75 (171.4)

Primary: OS&Y Secondary: OS&Y Bleed: needle (configuration: OON)

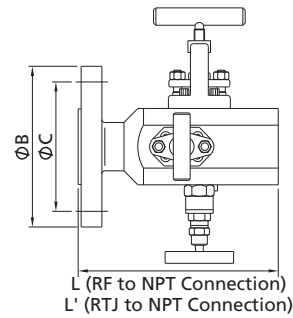
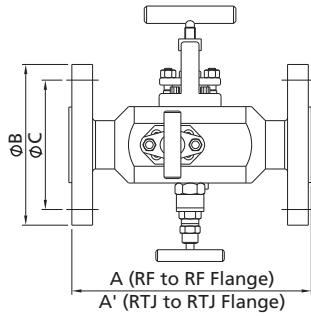

Flange Size	Bore Size in. (mm)	ASME Class	L in. (mm)	L' in. (mm)	A in. (mm)	A' in. (mm)	ϕB in. (mm)	ϕC in. (mm)		
NPS 1/2 (DN 15)	0.38 (9.5)	150	4.88 (124.0)	—	6.41 (162.8)	—	3.54 (90)	2.37 (60.3)		
		300		4.88 (124.0)	6.81 (173.0)	6.81 (173.0)	3.74 (95)	2.63 (66.7)		
		600	5.60 (142.2)	5.60 (142.2)	7.99 (202.9)	7.99 (202.9)	4.72 (120)	3.25 (82.6)		
		900/1500					5.31 (135)	3.50 (88.9)		
		2500					5.31 (135)	3.50 (88.9)		
NPS 3/4 (DN 20)	0.38 (9.5)	150	4.88 (124.0)	—	6.41 (162.8)	—	3.94 (100)	2.75 (69.9)		
		300		4.88 (124.0)	6.81 (173.0)	6.81 (173.0)	4.53 (115)	3.25 (82.6)		
		600	5.60 (142.2)	5.60 (142.2)	7.99 (202.9)	7.99 (202.9)	5.12 (130)	3.50 (88.9)		
		900/1500					5.51 (140)	3.75 (95.2)		
		2500					5.51 (140)	3.75 (95.2)		
NPS 1 (DN 25)	0.38 (9.5)	150	4.88 (124.0)	4.88 (124.0)	6.41 (162.8)	6.61 (167.9)	4.33 (110)	3.13 (79.4)		
		300			7.00 (177.8)	7.00 (177.8)	4.92 (125)	3.50 (88.9)		
		600	5.98 (151.9)	5.98 (151.9)	8.90 (226.1)	9.49 (241.0)	5.91 (150)	4.00 (101.6)		
		900/1500					10.30 (261.6)	10.30 (261.6)	6.30 (160)	4.25 (108.0)
		2500					10.70 (271.8)	10.70 (271.8)	6.30 (160)	4.25 (108.0)
NPS 1 1/2 (DN 40)	0.38 (9.5)	150	5.98 (151.9)	5.98 (151.9)	8.90 (226.1)	9.49 (241.0)	4.92 (125)	3.87 (98.4)		
		300			9.89 (251.2)	9.89 (251.2)	6.10 (155)	4.50 (114.3)		
		600	6.61 (167.9)	6.61 (167.9)	11.50 (292.1)	11.50 (292.1)	7.09 (180)	4.87 (123.8)		
		900/1500					12.40 (315.0)	12.40 (315.0)	8.07 (205)	5.75 (146)
		2500					12.40 (315.0)	12.40 (315.0)	8.07 (205)	5.75 (146)
NPS 2 (DN 50)	0.38 (9.5)	150	5.98 (151.9)	5.98 (151.9)	9.09 (230.9)	9.49 (241.0)	5.91 (150)	4.75 (120.7)		
		300			10.10 (256.5)	10.30 (261.6)	6.50 (165)	5.00 (127.0)		
		600	6.61 (167.9)	6.61 (167.9)	12.00 (304.8)	12.00 (304.8)	8.46 (215)	6.50 (165.1)		
		900/1500					7.00 (177.8)	7.00 (177.8)	9.25 (235)	6.75 (171.4)
		2500					7.00 (177.8)	7.00 (177.8)	9.25 (235)	6.75 (171.4)

Three-Piece Bolted Flange Double Block and Bleed Valves

Features

- ⦿ Complementing the existing one-piece range, flange to flange bolted construction DBB valves available in bore sizes from 3/8 in. to 2 in. (9.5 mm ~ 50.8 mm)
- ⦿ Designed and manufactured according to ASME SI B16.34 and ASME Boiler and Pressure Vessel Code, Section VIII
- ⦿ Three-piece, bolted joint, forged body design
- ⦿ API 607 Fire safe approved by TÜV SÜD. Anti-static design is also available.
- ⦿ Blowout-proof valve stems and needles
- ⦿ Materials are selected in accordance with NACE MR0175/ISO 15156
- ⦿ 1/2 female NPT standard vent

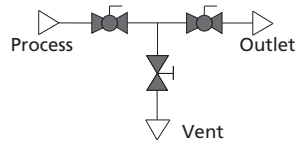
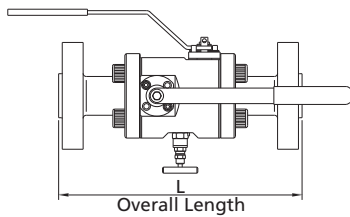

Dimensions

Basic Ordering Number	Flange Size	Bore Size in. (mm)	ASME Class	L in. (mm)
DBB□□-BBN1-□□8□□□-V□-FS-I	NPS 1/2 (DN 15)	1/2 (14)	150	12.6 (321)
			300	12.9 (327)
			600	13.4 (340)
			900/1500	14.4 (366)
			2500	15.0 (382)
DBB□□-BBN2-□□12□□□-V□-FS-I	NPS 3/4 (DN 20)	3/4 (20)	150	12.7 (323)
			300	13.2 (336)
			600	13.7 (349)
			900/1500	14.6 (372)
			2500	15.2 (385)
DBB□□-BBN3-□□16□□□-V□-FS-I	NPS 1 (DN 25)	1 (25.4)	150	13.0 (330)
			300	13.2 (336)
			600	13.8 (350)
			900/1500	15.4 (392)
			2500	16.2 (412)
DBB□□-BBN4-□□24□□□-V□-FS-I	NPS 1 1/2 (DN 40)	1 1/2 (38.1)	150	14.2 (361)
			300	14.4 (367)
			600	15.1 (384)
			900/1500	15.8 (402)
			2500	18.2 (463)
DBB□□-BBN5-□□32□□□-V□-FS-I	NPS 2 (DN 50)	2 (50.8)	150	15.4 (390)
			300	15.7 (398)
			600	16.4 (416)
			900/1500	18.9 (481)

Basic Ordering Number	Flange Size	Bore Size in. (mm)	ASME Class	L in. (mm)
DBB□□-BBN□□8□□□-V□-FS-I	NPS 1/2 (DN 15)	3/8 (9.5)	150	9.1 (232)
			300	9.9 (252)
			600	10.7 (272)
			900/1500	12.3 (312)
			2500	13.5 (342)
DBB□□-BBN1-□□12□□□-V□-FS-I	NPS 3/4 (DN 20)	1/2 (14)	150	12.8 (324)
			300	13.2 (336)
			600	13.8 (350)
			900/1500	14.6 (372)
			2500	15.2 (385)
DBB□□-BBN2-□□16□□□-V□-FS-I	NPS 1 (DN 25)	3/4 (20)	150	12.9 (327)
			300	13.4 (340)
			600	13.9 (353)
			900/1500	15.1 (384)
			2500	15.6 (397)
DBB□□-BBN3-□□24□□□-V□-FS-I	NPS 1 1/2 (DN 40)	1 (25.4)	150	13.1 (332)
			300	13.9 (352)
			600	15.0 (382)
			900/1500	15.8 (402)
			2500	16.6 (422)
DBB□□-BBN4-□□32□□□-V□-FS-I	NPS 2 (DN 50)	1 1/2 (38.1)	150	12.3 (312)
			300	13.1 (332)
			600	13.9 (352)
			900/1500	15.8 (402)
			2500	16.6 (422)
DBB□□-BBN5-□□48□□□-V□-FS-I	NPS 3 (DN 80)	2 (50.8)	150	14.3 (364)
			300	14.6 (372)
			600	16.9 (428)
			900	17.4 (441)
			1500	19.7 (500)

Dimensions are for reference only and are subject to change.

Root Double Block and Bleed Valves

Features

- ⦿ Directly-mounted root valves available to the vessel or process pipe
- ⦿ Weld inlet connections in sizes from NPS 1/2 to NPS 2
- ⦿ 1/2 female NPT standard vent with plug
- ⦿ 1/2 female NPT standard outlet
- ⦿ Orifice (ball-and-needle-valve configuration): Ball 3/8 in. (9.5 mm), Needle 0.16 in. (4 mm);
Orifice (all-needle-valve configuration): 0.16 in. (4 mm) is standard, 0.25 in. (6.4 mm) and 0.38 in. (9.5 mm) are available upon request.

Primary: ball Secondary: ball Bleed: needle (configuration: BBN)

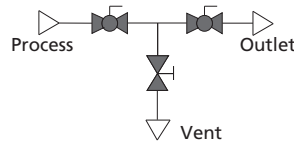
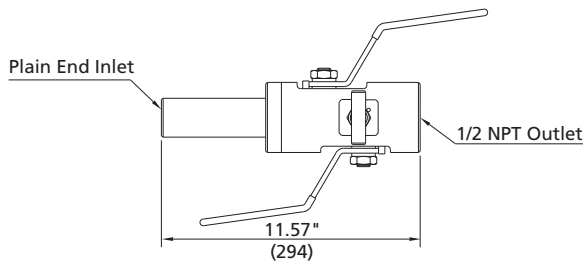

Primary: ball Secondary: ball Bleed: OS&Y (configuration: BBO)

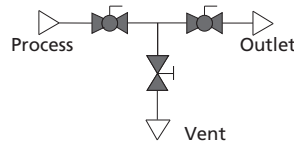
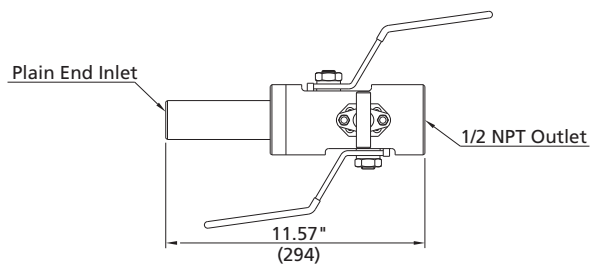

Primary: OS&Y Secondary: OS&Y Bleed: needle (configuration: OON)

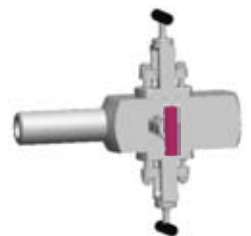
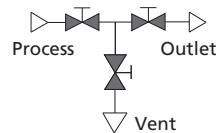
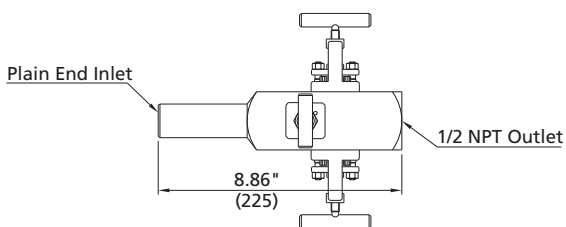

Primary: needle Secondary: needle Bleed: needle (configuration: NNN)

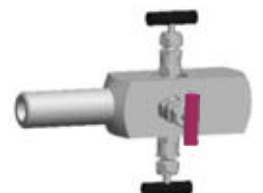
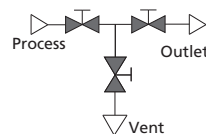
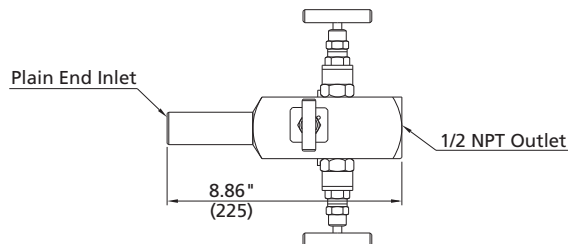

Dimensions are for reference only and are subject to change.

Monoflange Double Block & Bleed Valves

Features

- ⦿ Piping and instrument valves in one body
- ⦿ 1/4 female NPT standard vent with plug
- ⦿ 1/2 female NPT standard outlet
- ⦿ Orifice: 0.16 in. (4 mm) is standard, 0.25 in. (6.4 mm) and 0.38 in. (9.5 mm) are available for some flange sizes

Primary: OS&Y Secondary: needle Bleed: needle (configuration: ONN)

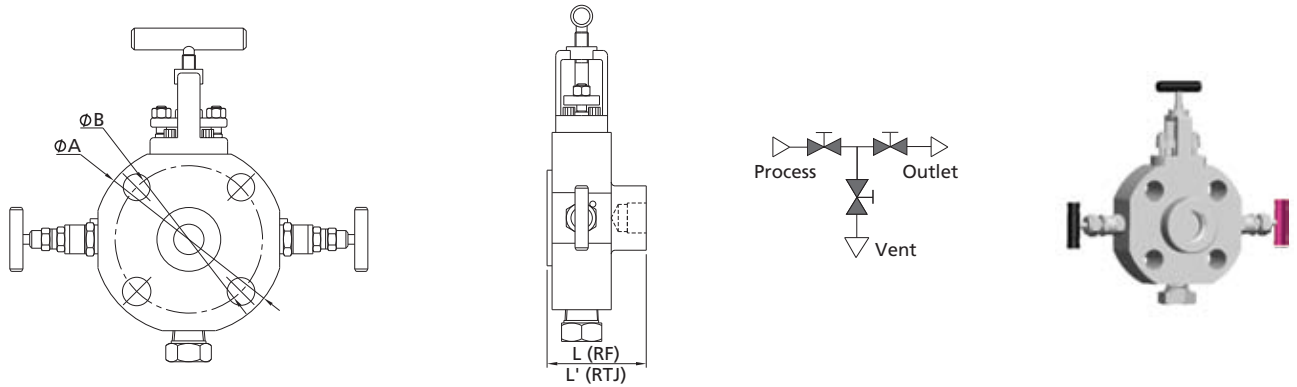

Primary: needle Secondary: needle Bleed: needle (configuration: NNN)

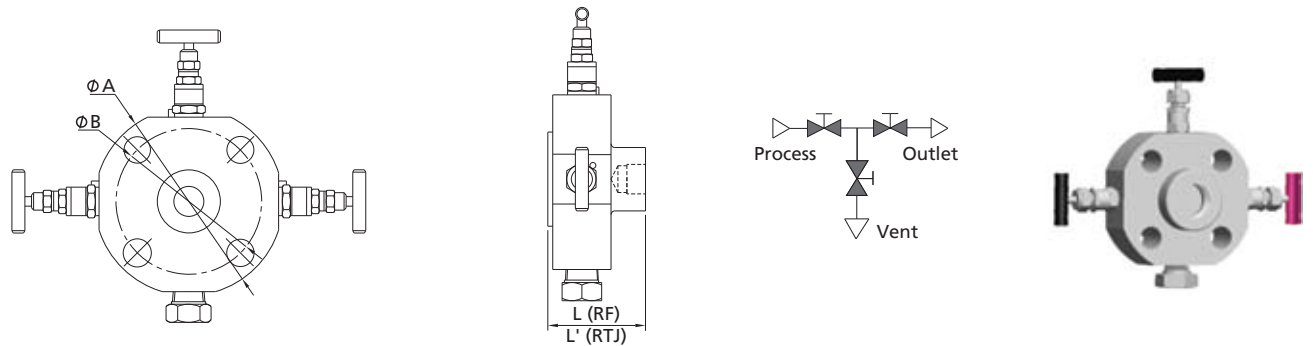

Primary: OS&Y Secondary: needle Bleed: needle (configuration: ONN, Block/Block/Bleed: X)

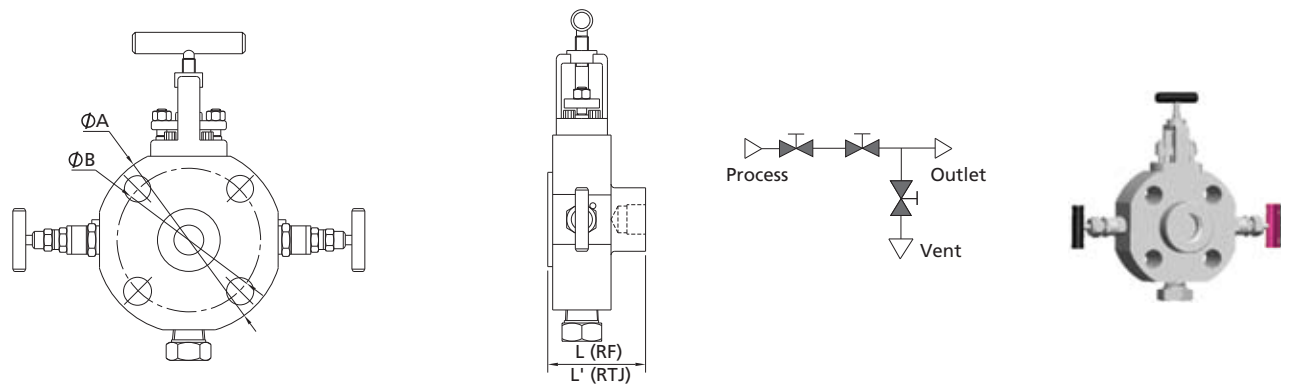

Manifolds

C-44 Block and Bleed Valves

Primary: needle Secondary: needle Bleed: needle (configuration: NNN, Block/Block/Bleed: X)

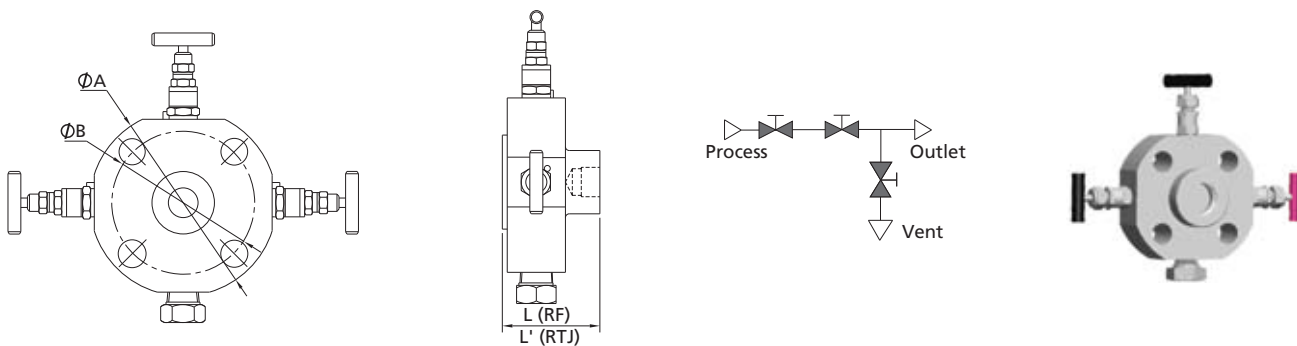

Flange Size	Bore Size in. (mm)	ASME Class	L in. (mm)	L' in. (mm)	ØA in. (mm)	ØB in. (mm)	
NPS 1/2 (DN 15)	0.16 (4.0)	150	2.03 (51.6)	—	3.54 (90)	2.37 (60.3)	
		300		2.03 (51.6)	3.74 (95)	2.63 (66.7)	
		600			4.72 (120)	3.25 (82.6)	
		900/1500			5.31 (135)	3.50 (88.9)	
		2500			—	3.94 (100)	2.75 (69.9)
NPS 3/4 (DN 20)		150	2.03 (51.6)	2.03 (51.6)	4.53 (115)	3.25 (82.6)	
		300			5.12 (130)	3.50 (88.9)	
		600			5.51 (140)	3.75 (95.2)	
		900/1500			2.11 (53.5)	2.11 (53.5)	5.51 (140)
NPS 1 (DN 25)		150	2.03 (51.6)	2.03 (51.6)	4.33 (110)	3.13 (79.4)	
	300	4.92 (125)			3.50 (88.9)		
	600	5.91 (150)			4.00 (101.6)		
	900/1500	2.11 (53.5)			2.11 (53.5)	6.30 (160)	4.25 (108.0)
	2500	2.03 (51.6)			2.03 (51.6)	4.92 (125)	3.87 (98.4)
NPS 1 1/2 (DN 40)	150	2.11 (53.5)	2.11 (53.5)	6.10 (155)	4.50 (114.3)		
	300			7.09 (180)	4.87 (123.8)		
	600			8.07 (205)	5.75 (146)		
	900/1500			2.19 (55.5)	2.19 (55.5)	5.91 (150)	4.75 (120.7)
	2500			2.67 (67.9)	2.67 (67.9)	6.50 (165)	5.00 (127.0)
NPS 2 (DN 50)	150	2.19 (55.5)	2.19 (55.5)	8.46 (215)	6.50 (165.1)		
	300			9.25 (235)	6.75 (171.4)		
	600			—	—		
	900/1500			2.42 (61.5)	2.42 (61.5)	—	—
	2500			2.88 (73.4)	2.88 (73.4)	—	—

Dimensions are for reference only and are subject to change.

Manifolds

Injection Double Block & Bleed Valves

Function - injection

Injection of chemicals and other media into the process stream can be accomplished with this design. A check valve is installed to prevent process fluid from reaching the inlet injection position. There is a 0.125" (3 mm) hole in the injection nozzle orifice. The length of the injection nozzle orifice can be manufactured to meet customer requirements.

The injection orifice can also be rotated. Injection valves can be provided in most of the styles and options offered for the DBB ranges.

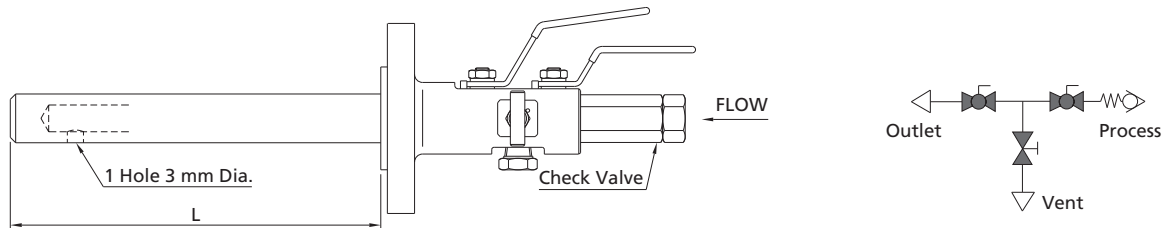

Injection Quill

The injection quill length (L) is manufactured to meet customer requirements.

The injection nozzle is a 3 mm diameter hole (standard).

Integral Check Valve

This poppet type spring return valve has a FKM soft seal (standard).

Sampling Double Block & Bleed Valves

Function - sampling

This design is developed to remove a sample directly from process stream at full system pressure. The customized sampling probe extends from the pipe flange connection for correct sample removal. Sampling valves can be provided without a probe and valves can be provided in most of the styles and options offered for the DBB ranges.

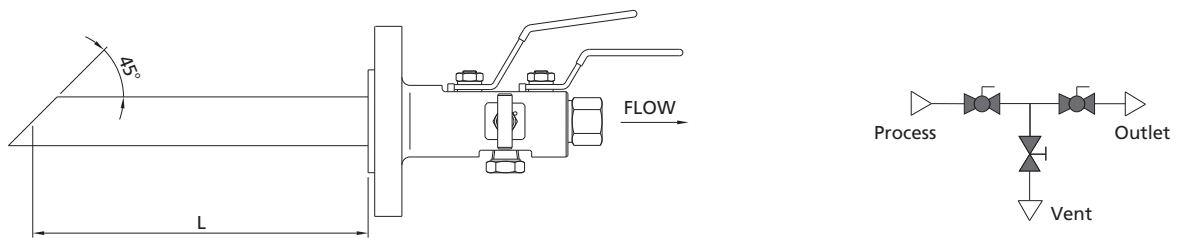

Sampling Probe

The sampling probe length (L) is manufactured to meet customer requirements.

DBSS - 1BBO1 - FM16300 - FNS8 - 2V8 - HGFS2 - IE

Ordering Number Description

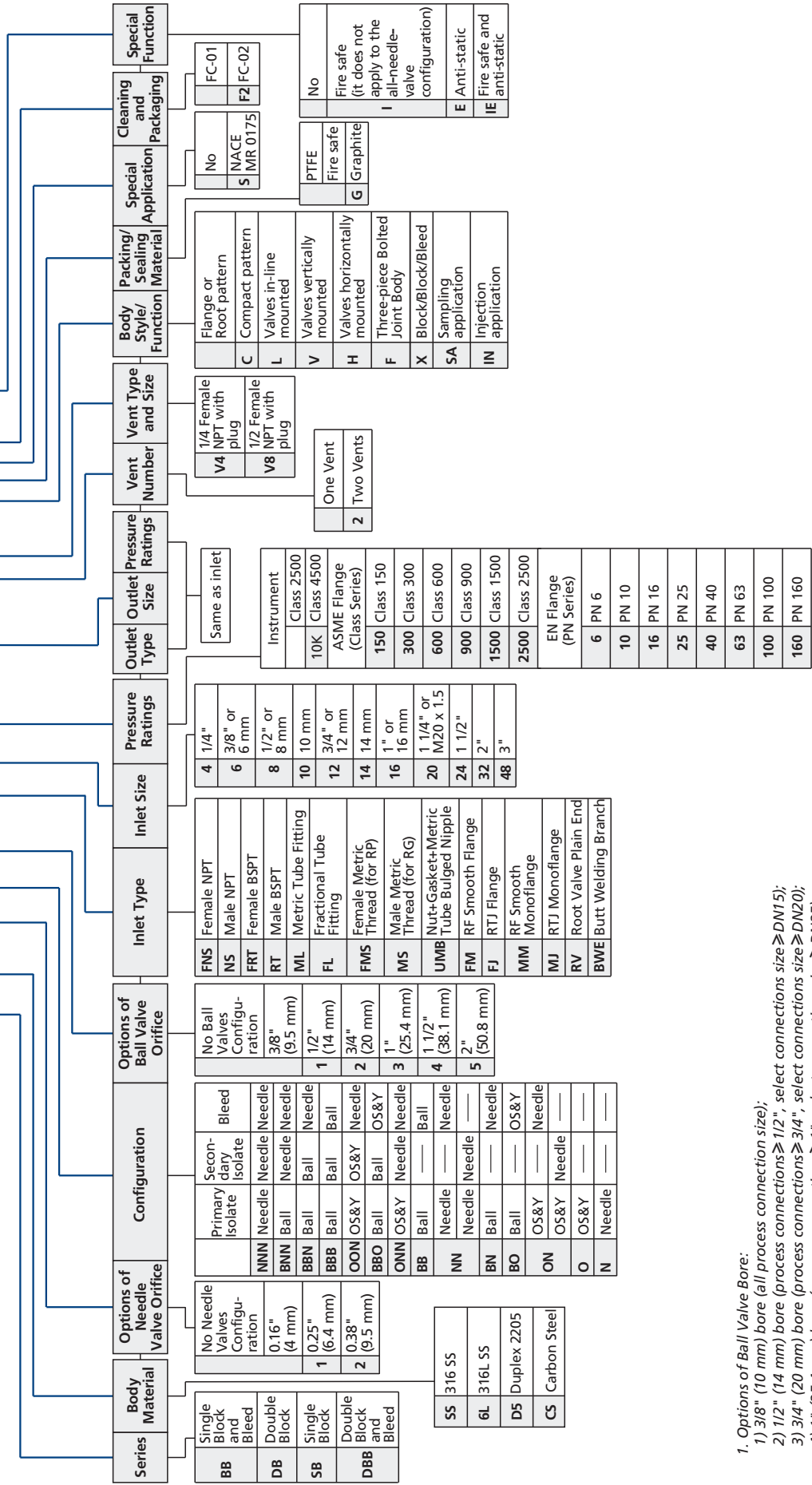

- Options of Ball Valve Bore:
 - 3/8" (10 mm) bore (all process connection size);
 - 1/2" (14 mm) bore (process connections $\geq 1/2"$, select connections size $\geq DN15$);
 - 3/4" (20 mm) bore (process connections $\geq 3/4"$, select connections size $\geq DN20$);
 - 1" (25.4 mm) bore (process connections $\geq 1"$, select connections size $\geq DN25$);
 - 1-1/2" (38.1 mm) bore (process connections $\geq 1-1/2"$, select connections size $\geq DN40$);
 - 2" (50.8 mm) bore (process connections $\geq 2"$, select connections size $\geq DN50$).
- For more information about hazards and risks of oxygen-enriched system, please contact FITOK Group or our authorized distributors.
- Cleaning and Packaging:
 - FC-01: Standard cleaning and packaging for general industrial procedures.
 - FC-02: Special cleaning and packaging for wetted system components to ensure compliance with product cleanliness requirement as stated in ASTM G93 Level C.

NOTE: "Ordering Number Description" is a reference to understand the combination rules of FITOK product part number. Not all combinations are available.

Manifolds

Air Headers and Distribution Manifolds

Air Headers and Distribution Manifolds



C-48

Air Headers and Distribution Manifolds

AH, AP, MP, MN and CM Series

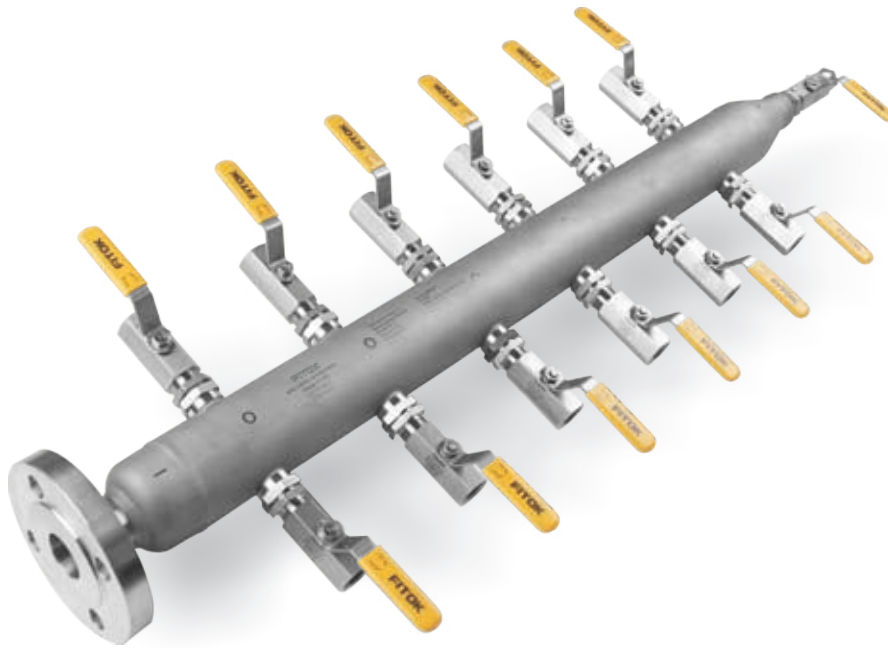

Air Headers and Distribution Manifolds

AH, AP, MP, MN and CM Series

Features

- ⦿ Distribution lines available upon request
- ⦿ Ball valve, plug valve, needle valve available for distribution lines and drain port
- ⦿ Color coded handles available
- ⦿ Leak-tight performance testing for every valve under nitrogen condition at the maximum working pressure

Pressure vs. Temperature

Air Headers

AH Series

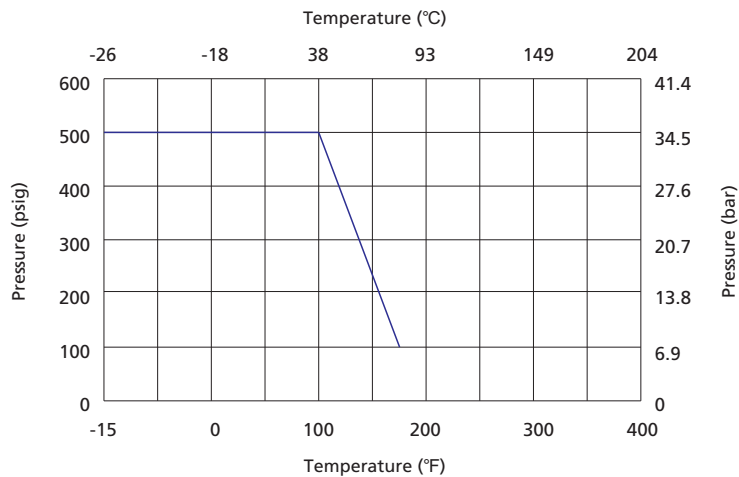

AP Series

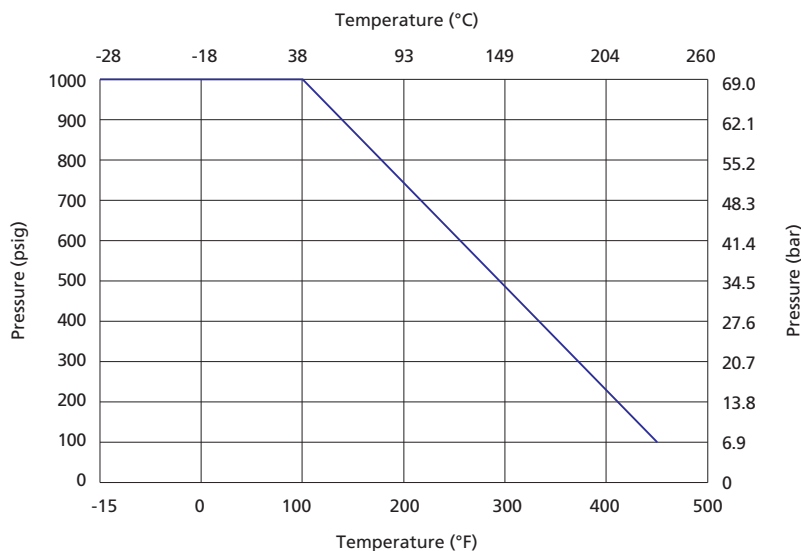

C-50 Air Headers and Distribution Manifolds

MP and MN Series

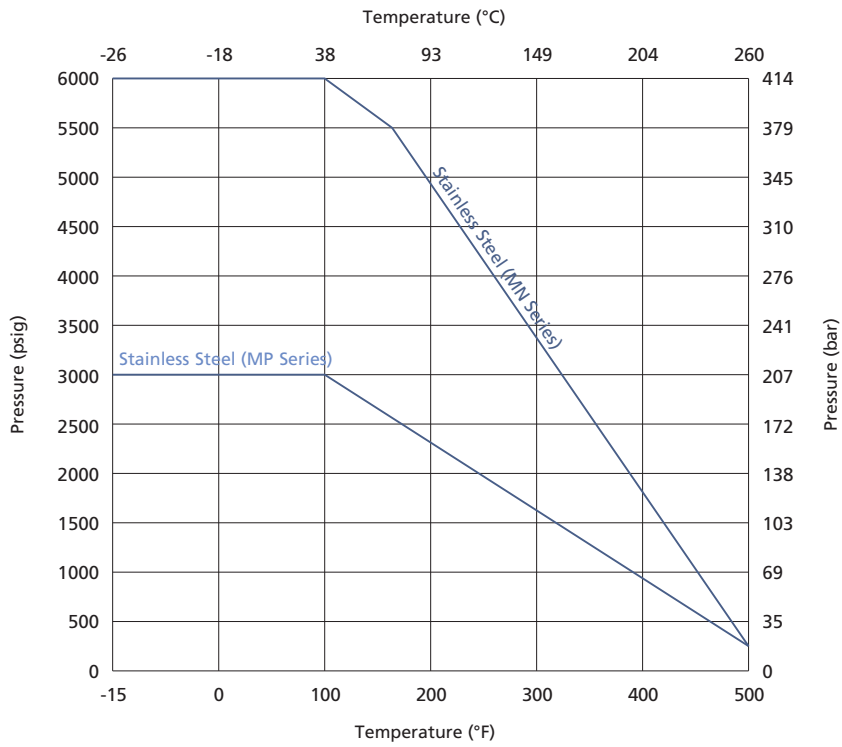

Distribution Manifolds

CM Series

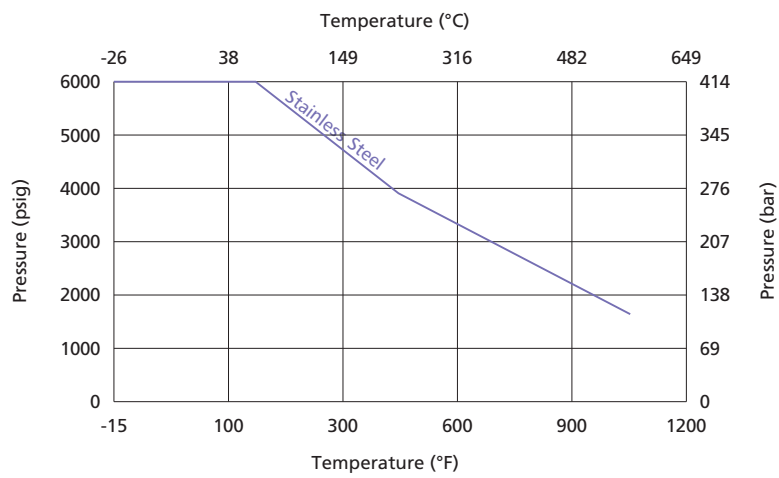

End Connections

AH, AP, MP, MN Series

Part	Type	Size	Standard
Inlet Connection	Male NPT	1/2, 3/4, 1	ASME B 1.20.1, GB/T 12716
	Female NPT		ISO 7/1, DIN 2999, GB/T 7306.2
	Female BSP Tapered		ISO 228-1, DIN 3852, GB/T 7307
	Female BSP Parallel		ANSI B 16.5
	Flange	Class 150, Class 300 PN16, PN25, PN40	GB/T 9115, EN 1092
Outlet Connection	Male NPT	1/4, 1/2	ASME B 1.20.1, GB/T 12716
	Female NPT		
	Fractional Tube Fitting	1/2"	FITOK Tube Fitting
	Metric Tube Fitting	12 mm	
Drain Connection	Female NPT	1/4, 1/2	ASME B 1.20.1, GB/T 12716
	Male NPT		

1. Sizes and types listed are standard. Other sizes and types are available upon request.

2. For dimensions not shown above, please contact FITOK Group or our authorized distributors.

CM Series

Part	Type	Size	Standard
Inlet Connection	Female NPT	1/2, 3/4, 1	ASME B 1.20.1, GB/T 12716
Outlet Connection	Female NPT	1/4, 3/8, 1/2	
Drain Connection	Female NPT	1/2, 3/4, 1	

1. Sizes and types listed are standard. Other sizes and types are available upon request.

2. For dimensions not shown above, please contact FITOK Group or our authorized distributors.

Construction

Air Headers

AH Series

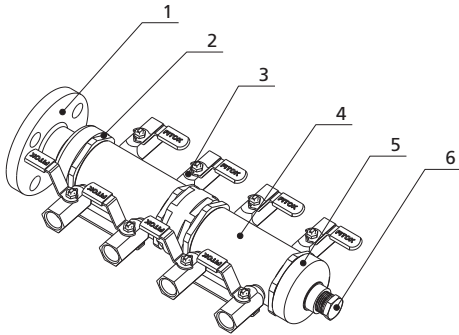

Caution:

Hold the valve body first when installing the fitting onto the outlet line. If the valve body bears large rotational torque, branch seal areas may be loose and leak may occur.

AP Series

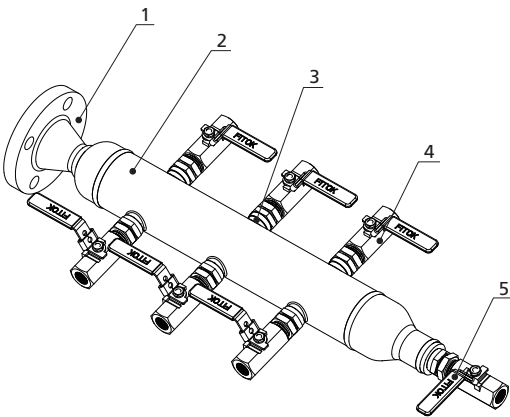

Standard Materials of Construction

Item	Component	Material/ASTM Specification	
1	Inlet Valve	BG Series Ball Valve	
	Flange	CF8/A351	CF8M/A351
2	Locking Nut	304SS/A312	
3	Distribution Valve	BR Series Ball Valve	
4	Main Line	304SS/A312	316SS/A312
5	Drain Connection	304SS/A479	316SS/A479
6	Drain Valve	BR Series Ball Valve	
	Plug	304 SS/A479	316 SS/A479

Optimized Setting of the Main Pipe and the Branch

Main Line Size	Quantity of Distribution Valves	Distance Between Two Outlets (mm)
NPS 2 (Sch 10)	4	Only 70
	8	

- Quantity of distribution valves listed is standard. Other types are available upon request.
- For dimensions not shown above, please contact FITOK Group or our authorized distributors.

Standard Materials of Construction

Item	Component	Material/ASTM Specification	
		Stainless Steel	
1	Inlet Valve	BG Series Ball Valve	
	Flange	304 SS/A182	316 SS/A182
2	Main Line	304 SS/A312	316 SS/A312
3	Branch Fitting	304 SS/A276	316 SS/A276
5	Distribution Valve	BR series ball valve as standard option	
	Drain Valve	BR series ball valve as standard option	
	Plug	304 SS/A276	316 SS/A276

Optimized Setting of the Main Pipe and the Branch

Main Line Size	Quantity of Distribution Valves	Distance Between Two Outlets (mm)
NPS 2 (Sch 10)	6	100
	12	

- Quantity of distribution valves listed is standard. Other sizes and types are available upon request.
- For dimensions not shown above, please contact FITOK Group or our authorized distributors.

MP Series

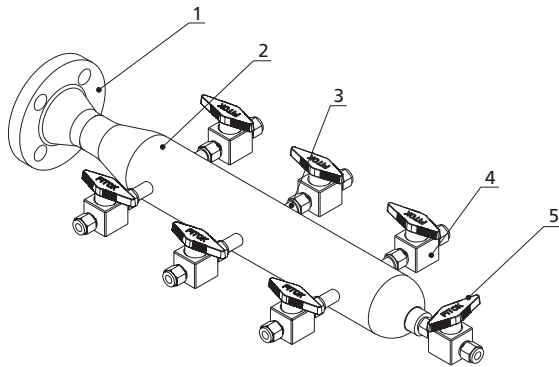

Standard Materials of Construction

Item	Component	Material/ASTM Specification	
		Stainless Steel	
1	Inlet Valve	BH Series Ball Valve	
	Flange	304 SS/A182	316 SS/A182
2	Main Line	304 SS/A312	316 SS/A312
3	Branch Fitting	304 SS/A276	316 SS/A276
4	Distribution Valve	PV series plug valve as standard option	
5	Drain Valve	PV series plug valve as standard option	
	Plug	304 SS/A276	316 SS/A276

Optimized Setting of the Main Pipe and the Branch

Main Line Size	Quantity of Distribution Valves	Distance Between Two Outlets (mm)
NPS 2 (Sch 160)	6	100
	12	

1. Quantity of distribution valves listed is standard. Other sizes and types are available upon request.
2. For dimensions not shown above, please contact FITOK Group or our authorized distributors.

MN Series

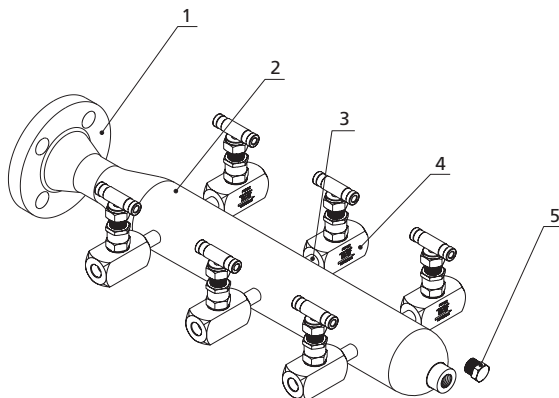

Standard Materials of Construction

Item	Component	Material/ASTM Specification	
		Stainless Steel	
1	Inlet Valve	NB Series needle valve	
	Flange	304 SS/A182	316 SS/A182
2	Main Line	304 SS/A312	316 SS/A312
3	Branch Fitting	304 SS/A276	316 SS/A276
4	Distribution Valve	NF series needle valve as standard option	
5	Drain Valve	NF series needle valve as standard option	
	Plug	304 SS/A276	316 SS/A276

Optimized Setting of the Main Pipe and the Branch

Main Line Size	Quantity of Distribution Valves	Distance Between Two Outlets (mm)
NPS 2 (Sch 160)	6	100~150*
	12	

* Distance between two outlets are determined by the distribution valves.

1. Quantity of distribution valves listed is standard. Other sizes and types are available upon request.
2. For dimensions not shown above, please contact FITOK Group or our authorized distributors.

Distribution Manifolds

CM Series

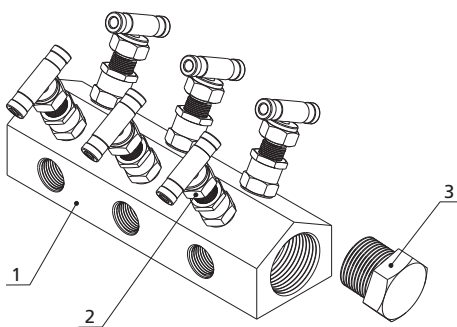

Standard Materials of Construction

Item	Component	Material/ASTM Specification	
		Stainless Steel	
1	Main Line	304 SS/A479	316 SS/A479
2	Distribution Valve	NB series needle valve	
3	Drain Plug	304 SS/A276	316 SS/A276

Carbon steel and other materials are available upon request.

Optimized Setting of the Main Pipe and the Branch

Quantity of Outlet Connections	Type and size of Outlet Connections	Distance Between Two Outlets (mm)
4~18	1/4" female NPT	60

1. Quantity of distribution valve listed are standard. Other sizes and types are available upon request.
2. For dimensions not shown above, please contact FITOK Group or our authorized distributors.

Ordering Number Description

AH Series

AHS4 – FNS8Y – 4ML10P – VFNS8 – C – F2

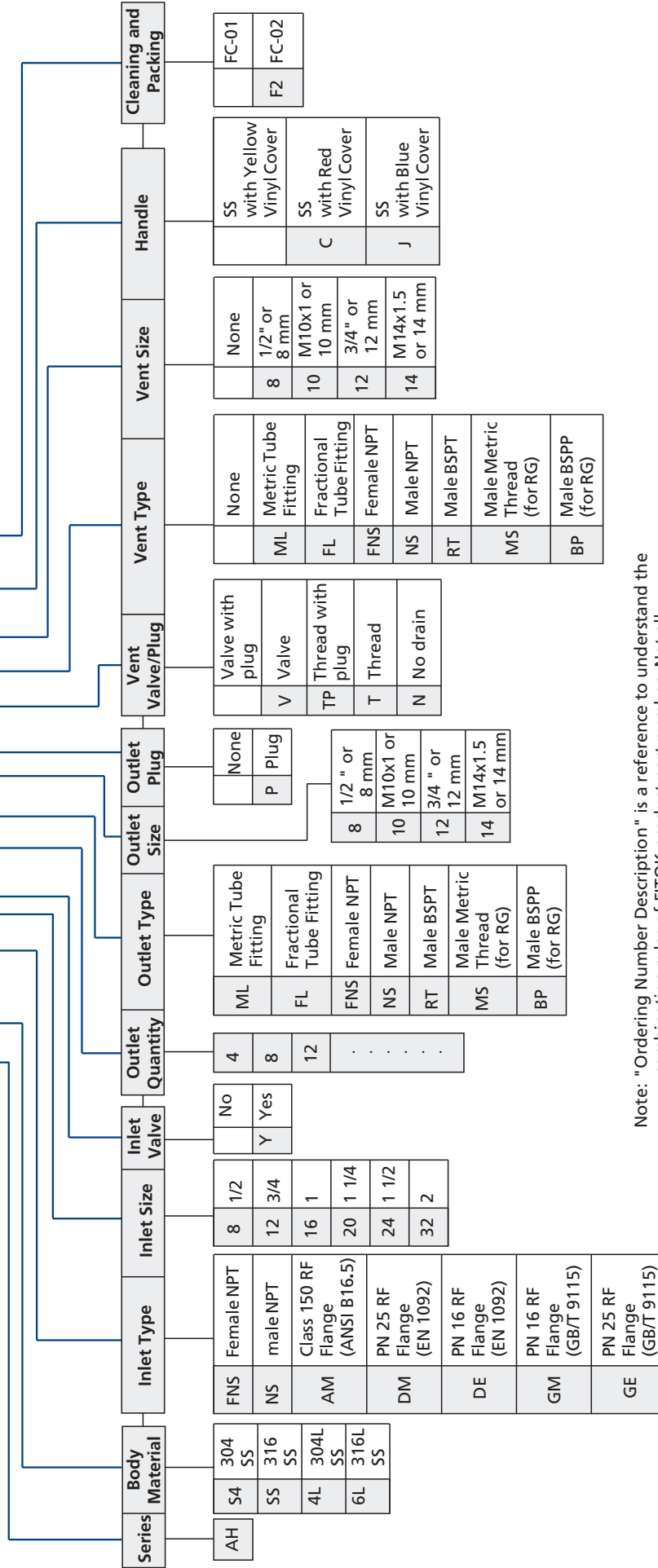

Note: "Ordering Number Description" is a reference to understand the combination rules of FITOK product part number. Not all combinations are available.

Cleaning and Packaging:

- FC-01: Standard cleaning and packaging for general industrial procedures.
- FC-02: Special cleaning and packaging for wetted system components to ensure compliance with product cleanliness requirements as stated in ASTM G93 Level C.

AP Series

APSS – FNS16Y – 8NS12T – TNS8 – C – SF2

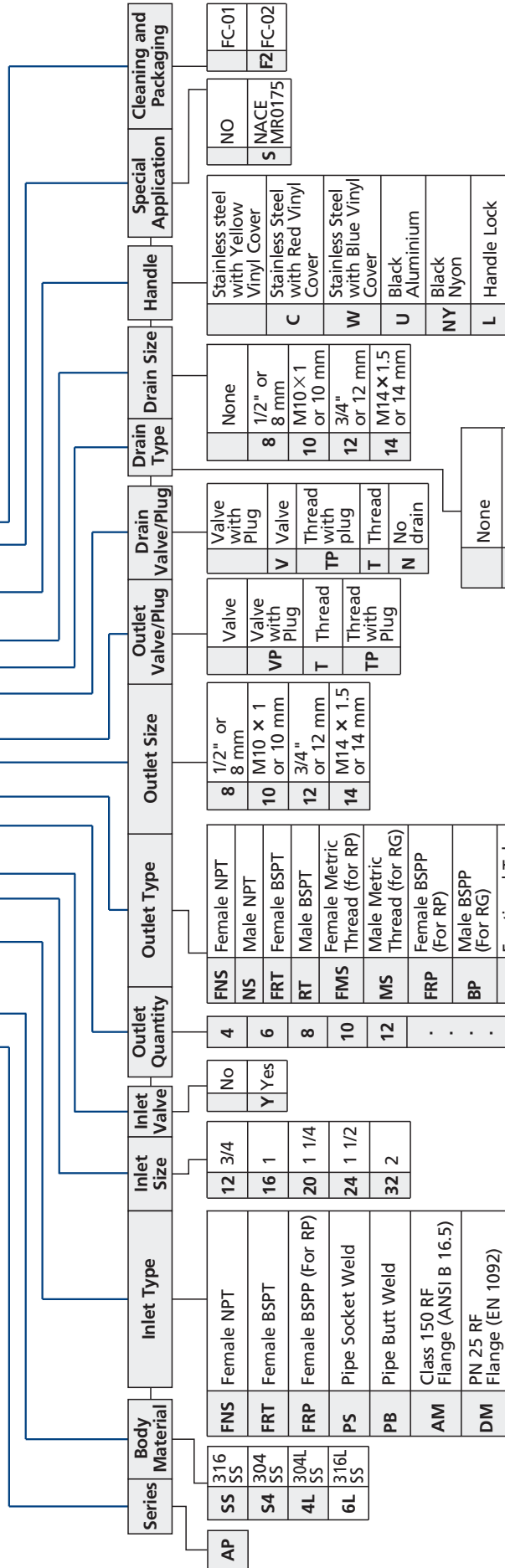

Series	Body Material	Inlet Type	Inlet Size	Inlet Valve	Outlet Quantity	Outlet Type	Outlet Size	Outlet Valve/Plug	Drain Valve/Plug	Drain Type	Drain Size	Handle	Special Application	Cleaning and Packaging
AP	316 SS	FNS Female NPT	12 3/4	No	4	FNS Female NPT	8 1/2" or 8 mm	Valve with Plug	Valve with Plug	8	None	Stainless steel with Yellow Vinyl Cover	NO	FC-01
SS	304 SS	FRT Female BSPT	16 1	Y	6	NS Male NPT	M10 x 1 or 10 mm	Valve with Plug	VP Valve with Plug	10	M10 x 1 or 10 mm	Stainless Steel with Red Vinyl Cover	NACE S	FC-02
S4	304L SS	FRP Female BSPP (For RP)	20 1 1/4		8	FRT Female BSPT	3/4"	Thread	T Thread with plug	10	M10 x 1 or 10 mm	Stainless Steel with Blue Vinyl Cover		
4L	316L SS	PS Pipe Socket Weld	24 1 1/2		10	RT Male BSPT	M14 x 1.5 or 14 mm	Thread with Plug	TP Thread with plug	12	3/4" or 12 mm			
6L		PB Pipe Butt Weld	32 2		12	FMS Female Metric Thread (for RP)		Thread with Plug	T Thread	14	M14 x 1.5 or 14 mm			
		AM Class 150 RF Flange (ANSI B 16.5)			.	MS Male Metric Thread (for RG)		No drain	N No drain			Black Aluminium		
		DM PN 25 RF Flange (EN 1092)			.	FRP Female BSPP (For RP)						Black Nylon		
		DE PN 16 RF Flange (EN 1092)			.	BP Male BSPP (For RG)						Handle Lock		
		GM PN 16 RF Flange (GB/T 9115)			.	FL Fractional Tube Fitting								
		GE PN 25 RF Flange (GB/T 9115)			.	ML Metric Tube Fitting								
		AET Class 300 RF Flange (ANSI B 16.5)				UFB Nut+Gasket+Fractional BulgeNipple								
		DMT PN 40 RF Flange (EN 1092)				UMB Nut+Gasket+Metric Bulge Nipple								
		GMT PN 40 RF Flange (GB/T 9115)												

Note: "Ordering Number Description" is a reference to understand the combination rules of FITOK product part number. Not all combinations are available.

Cleaning and Packaging:

FC-01: Standard cleaning and packaging for general industrial procedures.

FC-02: Special cleaning and packaging for wetted system components to ensure compliance with product cleanliness requirements as stated in ASTM G93 Level C.

None	FNS	Female NPT
Female NPT	NS	Male NPT
Male NPT	FRT	Female BSPT
Female BSPT	RT	Male BSPT
Male BSPT	FMS	Female Metric Thread (for RP)
Female Metric Thread (for RP)	MS	Male Metric Thread (for RG)
Male Metric Thread (for RG)	FRP	Female BSPP (For BP)
Female BSPP (For BP)	BP	Male BSPP (For RG)
Male BSPP (For RG)	FL	Fractional Tube Fitting
Fractional Tube Fitting	ML	Metric Tube Fitting
Metric Tube Fitting		

MP, MN Series

MNSS – FNS16Y – 10NS8T – BFNS8 – C – SF2

Series	Body Material	Inlet Type	Inlet Size	Inlet Valve	Outlet Quantity	Outlet Type	Outlet Size	Outlet Valve/Plug	Drain Type	Drain Valve/Plug	Drain Size	Handle	Special Application	Cleaning and Packaging
MP	SS 316 SS	FNS Female NPT	12 3/4	No	4	Female NPT	8 1/2" or 8 mm	Valve	FNS	Female NPT	8	None	NO	FC-01
MN	S4 304 SS	FRT Female BSPT	16 1	Y Yes	6	Male NPT	10 M10 x 1 or 10 mm	VP Valve with Plug	NS	Male NPT	8	1/2" or 8 mm	INACE S IMR0175	F2 FC-02
	4L 304L SS	FRP Female BSPP (For RP)	20 1 1/4		8	Female BSPT	12 3/4" or 12 mm	T Thread	FRT	Female BSPT	10	M10 x 1 or 10 mm		
	6L 316L SS	PS Pipe Socket Weld	24 1 1/2		10	Male BSPT	14 M14 x 1.5 or 14 mm	TP Thread with Plug	RT	Male BSPT	12	3/4" or 12 mm		
		PB Pipe Butt Weld	32 2		12	Female Metric Thread (for RP)			FMS	Female Metric Thread (for RP)	14	M14 x 1.5 or 14 mm		Black Aluminum Bar
		AM Class 2500 RF Flange (ANSI B 16.5)			.	Male Metric Thread (for RG)			MS	Male Metric Thread (for RG)				Red Aluminum Bar
		DM PN 420 RF Flange (EN 1092)			.	Female BSPP (For RP)		Valve with Plug	FRP	Female BSPP (For RP)				Green Aluminum Bar
		GM PN 420 RF Flange (GB/T 9115)			.	Male BSPP (For RG)		V Valve	BP	Male BSPP (For RG)				Blue Aluminum Bar
						Fractional Tube Fitting		TP Thread with plug	FL	Fractional Tube Fitting				321 Stainless Steel Bar
						Metric Tube Fitting		T Thread	ML	Metric Tube Fitting				
						Nut+Gasket+Fractional Bulge Nipple		N No drain	UFB	Nut+Gasket+Fractional Bulge Nipple				
						Nut+Gasket+Metric Bulge Nipple			UMB	Nut+Gasket+Metric Bulge Nipple				

Note: "Ordering Number Description" is a reference to understand the combination rules of FITOK product part number. Not all combinations are available.

Cleaning and Packaging:

FC-01: Standard cleaning and packaging for general industrial procedures.

FC-02: Special cleaning and packaging for wetted system components to ensure compliance with product cleaning requirement as stated in ASTM G93 Level C.

CM Series

CMSS – FNS16 – 8FNS12P – 12T – C – SF2

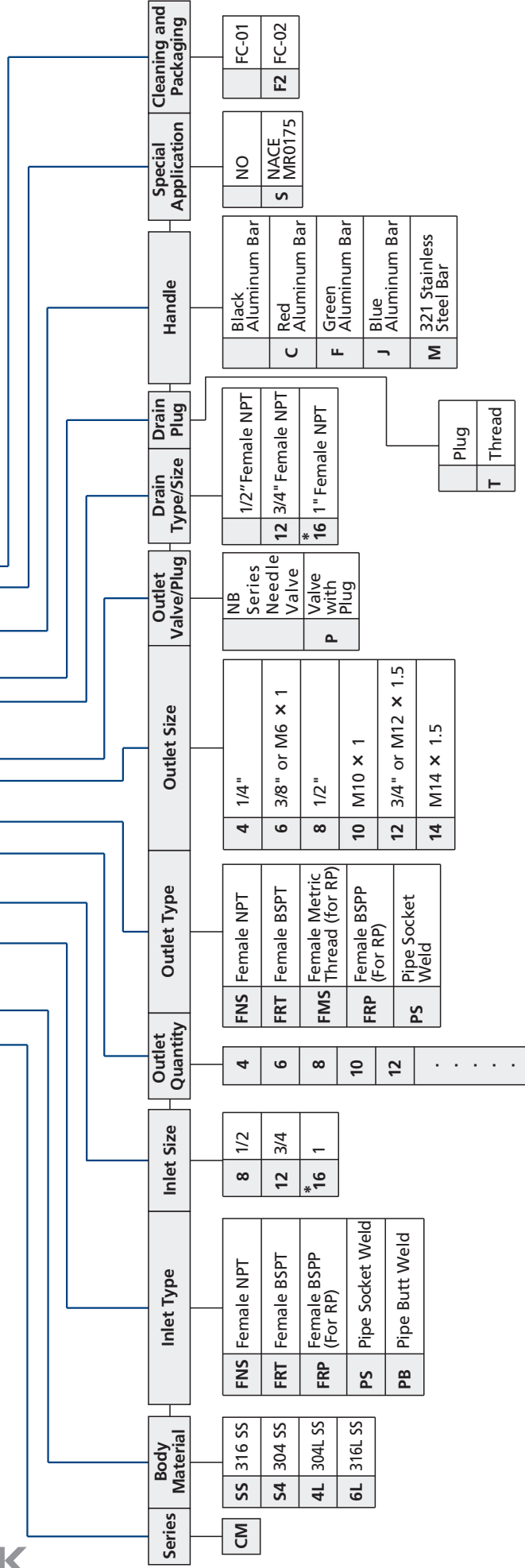

Note: * only applies to maximum working pressure up to 3000 psig.
 "Ordering Number Description" is a reference to understand the combination rules of FITOK product part number. Not all combinations are available.

Cleaning and Packaging:
 FC-01: Standard cleaning and packaging for general industrial procedures.
 FC-02: Special cleaning and packaging for wetted system components to ensure compliance with product cleaning requirement as stated in ASTM G93 Level C.