

Sour Service Products

Medium Pressure Tube Fittings and Tubing



E-05

High Pressure Tube Fittings and Tubing



E-08

Pipe Fittings



E-11

Adapters and Couplings



E-13

Needle Valves

Pressures to 30,000 psig (2068 bar)



E-15

Bleed Valves

Pressures to 20,000 psig (1379 bar)



E-28

Gauge Valves

Pressures to 20,000 psig (1379 bar)



E-31

Check Valves

Pressures to 30,000 psig (2068 bar)



E-35

Sour Service Products

- Fittings and Tubing, 30,000 psig (2068 bar)
- Needle Valves, 30,000 psig (2068 bar)
- Bleed Valves, 20,000 psig (1379 bar)
- Gauge Valves, 20,000 psig (1379 bar)
- Check Valves, 30,000 psig (2068 bar)



Medium & High Pressure Fittings and Tubing
Quick Couplings
Medium & High Pressure Valves
Line Filters
Sour Service Products
Subsea Valves
Tools and Installation Instructions
Technical Information

Contents

Medium Pressure Tube Fittings and Tubing

E-05

High Pressure Tube Fittings and Tubing

E-08

Pipe Fittings

E-11

Adapters and Couplings

E-13

Needle Valves

Pressures to 30,000 psig (2068 bar)

E-15

Bleed Valves

Pressures to 20,000 psig (1379 bar)

E-28

Gauge Valves

Pressures to 20,000 psig (1379 bar)

E-31

Check Valves

Pressures to 30,000 psig (2068 bar)

E-35

Medium & High Pressure
Fittings and Tubing

Quick Couplings

Medium & High Pressure
Valves

Line Filters

Sour Service Products

Subsea Valves

Tools and Installation
Instructions

Technical Information

FITOK designs and manufactures medium & high pressure valves, fittings and tubing for use with sour oil and gas (H₂S). These components, are also referred to as FITOK type "S" components.

Sour Oil and Gas Service (H₂S) or Standard Service

FITOK's oil field components are offered for standard oil field service where H₂S is not present and type "S" for service where H₂S is present. FITOK's S components are manufactured with materials and procedures specified for optimum resistance to H₂S. These material specifications and manufacturing procedures are continually updated to incorporate the latest advances and customer requirements.

Working Pressure/Temperature

Valves and fittings for standard service are rated for working pressure up to 60,000 psig (4137 bar) at 100°F (38°C). Type S components are rated up to 30,000 psig (2068 bar) at 100°F (38°C).

Sizes:

FITOK's type S valves and fittings are supplied with standard API test and gauge connections. Conned-and-threaded tubing connections in other sizes are available to meet individual requirement. FITOK stocks a wide selection of sizes for immediate shipment.

NACE MR0175 Compliant Materials:

FITOK standard series valves and fittings are type 316 stainless steel, cold worked material. Type S valves and fittings are 316 stainless steel annealed material. If required, complete material specifications are provided. All pressure-containing materials used are in accordance with NACE MR0175.

Medium & High Pressure
Fittings and Tubing

Quick Couplings

Medium & High Pressure
Valves

Line Filters

Sour Service Products

Subsea Valves

Tools and Installation
Instructions

Technical Information

Medium Pressure Tube Fittings and Tubing

Tube Fittings

Features

- ⦿ Maximum working pressure: 10,000 psig (690 bar)
- ⦿ Coned-and-threaded connection
- ⦿ Tube sizes available in 1/4", 3/8", 9/16", 3/4" and 1"
- ⦿ Annealed 316 Stainless Steel as standard material, other materials available upon request
- ⦿ Anti-vibration connection components available
- ⦿ Easy to disconnect and retighten
- ⦿ Metal-to-metal seal to provide perfect leak-tight service for working conditions from critical vacuum to medium pressure
- ⦿ Every fitting marked with size, material and heat number

Construction

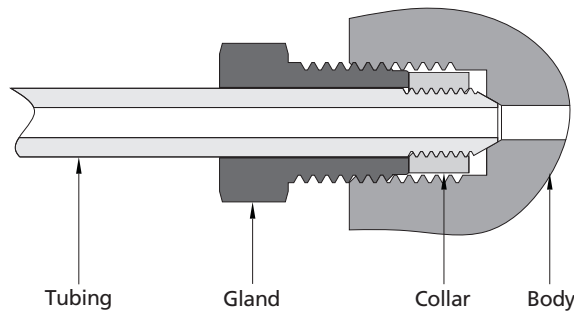

Ordering Information

The structure of FITOK's type S tube fittings are the same as standard medium pressure tube fittings. To get the complete ordering number of type S medium pressure tube fittings, add "-S" as a suffix to the ordering number of standard medium pressure tube fittings. If glands and collars are not needed, add "-SWO" as a suffix.

Examples:

1. 9/16" Union, the ordering number is SS-U-2FH9-S.
2. 3/8" Tee, glands and collars are not needed, the ordering number is SS-TTT-2FH6-SWO.

The sizes of type S tube fittings are the same as standard medium pressure tube fittings, please refer to the FITOK catalog *Medium Pressure Tube Fittings and Tubing* on A-16.

Tubing

Features

- ⦿ Maximum working pressure: 10,000 psig (690 bar)
- ⦿ Working temperature range: -423°F to 1200°F (-252°C to 649°C)
- ⦿ Annealed 316/316L Stainless Steel as standard material, other materials available upon request
- ⦿ Every tubing marked with material, size and heat number

Ordering Information

T - Tube O.D. in.	Tx - Tube I.D. in.	Material	Basic Ordering Number	Tolerance O.D. in. (mm)
1/4	0.109	Annealed 316/316L SS	SS-MT-2FH4-	0.248/0.243 (6.30/6.17)
3/8	0.203	Annealed 316/316L SS	SS-MT-2FH6-	0.370/0.365 (9.40/9.27)
9/16	0.312	Annealed 316/316L SS	SS-MT-2FH9-	0.557/0.552 (14.15/14.02)
3/4	0.438	Annealed 316/316L SS	SS-MT-2FH12-	0.745/0.740 (18.92/18.80)
1	0.562	Annealed 316/316L SS	SS-MT-2FH16-	0.995/0.990 (25.27/25.14)



To get the complete ordering number of type S tubing, add the length designator and "-S" as a suffix to the basic ordering number.

Examples:

1. If 10 feet of 3/8" O.D. tubing is needed, the complete ordering number is SS-MT-2FH6-**10-S**.
2. If 6 meters of 3/4" O.D. tubing is needed, the complete ordering number is SS-MT-2FH12-**6M-S**.

The tubing is available in random lengths but no more than 20 feet (6 meters).

Medium & High Pressure Fittings and Tubing

Quick Couplings

Medium & High Pressure Valves

Line Filters

Sour Service Products

Subsea Valves

Tools and Installation Instructions

Technical Information

Coned and Threaded Nipples

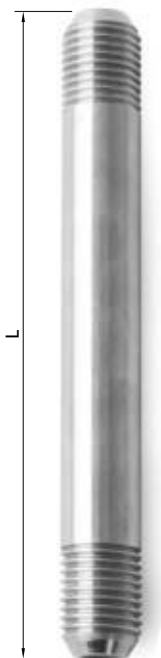

T - Tube O.D. in.	Tx - Tube I.D. in.	Ordering Number	L in. (mm)
1/4	0.109	SS-CTN-2FH4-2.75-S	2.75 (69.9)
1/4	0.109	SS-CTN-2FH4-3-S	3 (76.2)
1/4	0.109	SS-CTN-2FH4-4-S	4 (101.6)
1/4	0.109	SS-CTN-2FH4-6-S	6 (152.4)
1/4	0.109	SS-CTN-2FH4-8-S	8 (203.2)
1/4	0.109	SS-CTN-2FH4-10-S	10 (254.0)
1/4	0.109	SS-CTN-2FH4-12-S	12 (304.8)
3/8	0.203	SS-CTN-2FH6-3-S	3 (76.2)
3/8	0.203	SS-CTN-2FH6-4-S	4 (101.6)
3/8	0.203	SS-CTN-2FH6-6-S	6 (152.4)
3/8	0.203	SS-CTN-2FH6-8-S	8 (203.2)
3/8	0.203	SS-CTN-2FH6-10-S	10 (254.0)
3/8	0.203	SS-CTN-2FH6-12-S	12 (304.8)
9/16	0.312	SS-CTN-2FH9-4-S	4 (101.6)
9/16	0.312	SS-CTN-2FH9-6-S	6 (152.4)
9/16	0.312	SS-CTN-2FH9-8-S	8 (203.2)
9/16	0.312	SS-CTN-2FH9-10-S	10 (254.0)
9/16	0.312	SS-CTN-2FH9-12-S	12 (304.8)
3/4	0.438	SS-CTN-2FH12-4-S	4 (101.6)
3/4	0.438	SS-CTN-2FH12-6-S	6 (152.4)
3/4	0.438	SS-CTN-2FH12-8-S	8 (203.2)
3/4	0.438	SS-CTN-2FH12-10-S	10 (254.0)
3/4	0.438	SS-CTN-2FH12-12-S	12 (304.8)
1	0.562	SS-CTN-2FH16-6-S	6 (152.4)
1	0.562	SS-CTN-2FH16-8-S	8 (203.2)
1	0.562	SS-CTN-2FH16-10-S	10 (254.0)
1	0.562	SS-CTN-2FH16-12-S	12 (304.8)

NOTE: Do not recommend bending of tubing.

Installation Instructions

Please see G-07.

Medium & High Pressure Fittings and Tubing
Quick Couplings
Medium & High Pressure Valves
Line Filters
Sour Service Products
Subsea Valves
Tools and Installation Instructions
Technical Information

High Pressure Tube Fittings and Tubing

Tube Fittings

Features

- ⦿ Maximum working pressure: 30,000 psig (2068 bar)
- ⦿ Working temperature range: -423°F to 1200°F (-252°C to 649°C)
- ⦿ Coned-and-threaded connection
- ⦿ Annealed 316 Stainless Steel as standard material, other materials available upon request
- ⦿ Anti-vibration connection components available
- ⦿ Easy to disconnect and retighten
- ⦿ Metal-to-metal seal to provide perfect leak-tight service from critical vacuum to high pressure
- ⦿ Every fitting marked with size, material and heat number

Construction

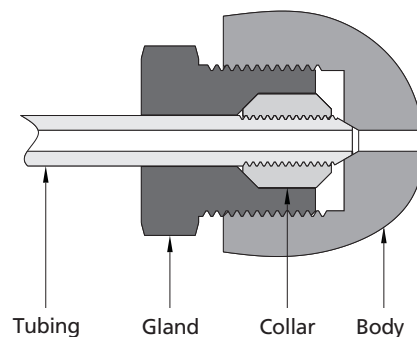

Ordering Information

The structure of FITOK's type S tube fittings are the same as standard high pressure tube fittings. To get the complete ordering number of type S high pressure tube fittings, add "-S" as a suffix to the ordering number of standard high pressure tube fittings. If glands and collars are not needed, add "-SWO" as a suffix.

Examples:

1. 9/16" Union, the ordering number is SS-U-6FH9-S.
2. 3/8" Tee, glands and collars are not needed, the ordering number is SS-TTT-6FH6-SWO.

The sizes of type S tube fittings are the same as standard high pressure tube fittings, please refer to the FITOK catalog *High Pressure Tube Fittings and Tubing* on A-26.

Tubing

Features

- ⦿ Maximum working pressure: 30,000 psig (2068 bar)
- ⦿ Working temperature range: -423°F to 1200°F (-252°C to 649°C)
- ⦿ Annealed 316/316L Stainless Steel as standard material, other materials available upon request
- ⦿ Every tubing marked with material, size and heat number

Ordering Information

T - Tube O.D. in.	Tx - Tube I.D. in.	Material	Basic Ordering Number	Tolerance O.D. in. (mm)
1/4	0.083	Annealed 316/316L SS	SS-HT-6FH4-	0.248/0.243 (6.30/6.17)
3/8	0.125	Annealed 316/316L SS	SS-HT-6FH6-	0.370/0.365 (9.40/9.27)
9/16	0.188	Annealed 316/316L SS	SS-HT-6FH9-	0.557/0.552 (14.15/14.02)



To get the complete ordering number of type S tubing, add the length designator and "-S" as a suffix to the basic ordering number.

Examples:

1. If 10 feet of 1/4" O.D. tubing is needed, the complete ordering number is SS-HT-6FH4-**10-S**.
2. If 6 meters of 9/16" O.D. tubing is needed, the complete ordering number is SS-HT-6FH9-**6M-S**.

The tubing is available in random lengths but no more than 20 feet (6 meters).

Coned and Threaded Nipples

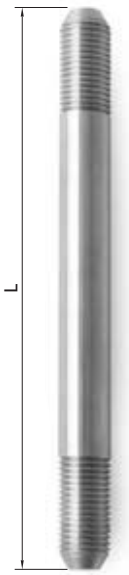

T - Tube O.D. in.	Tx - Tube I.D. in.	Ordering Number	L in. (mm)
1/4	0.083	SS-CTN-6FH4-2.75-S	2.75 (69.9)
1/4	0.083	SS-CTN-6FH4-3-S	3 (76.2)
1/4	0.083	SS-CTN-6FH4-4-S	4 (101.6)
1/4	0.083	SS-CTN-6FH4-6-S	6 (152.4)
1/4	0.083	SS-CTN-6FH4-8-S	8 (203.2)
1/4	0.083	SS-CTN-6FH4-10-S	10 (254.0)
1/4	0.083	SS-CTN-6FH4-12-S	12 (304.8)
3/8	0.125	SS-CTN-6FH6-3-S	3 (76.2)
3/8	0.125	SS-CTN-6FH6-4-S	4 (101.6)
3/8	0.125	SS-CTN-6FH6-6-S	6 (152.4)
3/8	0.125	SS-CTN-6FH6-8-S	8 (203.2)
3/8	0.125	SS-CTN-6FH6-10-S	10 (254.0)
3/8	0.125	SS-CTN-6FH6-12-S	12 (304.8)
9/16	0.188	SS-CTN-6FH9-4-S	4 (101.6)
9/16	0.188	SS-CTN-6FH9-6-S	6 (152.4)
9/16	0.188	SS-CTN-6FH9-8-S	8 (203.2)
9/16	0.188	SS-CTN-6FH9-10-S	10 (254.0)
9/16	0.188	SS-CTN-6FH9-12-S	12 (304.8)

NOTE: Do not recommend bending of tubing.

Installation Instructions

Please see G-07.

Medium & High Pressure
Fittings and Tubing

Quick Couplings

Medium & High Pressure
Valves

Line Filters

Sour Service Products

Subsea Valves

Tools and Installation
Instructions

Technical Information

Pipe Fittings

Features

- ⦿ Annealed 316 Stainless Steel as standard material, other materials available upon request
- ⦿ The hardened threads with smooth surface finishing avoid galling and help to extend the fitting service life
- ⦿ Radius junction design with elbows provides smooth flow path
- ⦿ Every fitting marked with size, material and heat number

Thread Specifications

Connection Type	Code	Thread Type	Thread Specification
Male or Female NPT	NS	NPT	ASME B1.20.1, SAE AS71051
Male or Female ISO/BSP Tapered	RT	ISO/BSP Tapered	ISO 7-1, BS EN 10226-1, DIN EN10226-1, JIS B0203
Male or Female JIC (37° Flare)	AN		
Female Swivel JIC (37° Flare)	AS	SAE/MS	ASME B1.1
Male Type "M"	HM		

Working Pressure

- ⦿ The pressures of pipe fittings are dependent on the end connection with the lowest working pressure.
- ⦿ The pressures of the end connections are shown in the table below.

End Connection	Working Pressure psig (bar)	End Connection	Working Pressure psig (bar)	End Connection	Working Pressure psig (bar)
NS2	10,000 (690)	RT2	10,000 (690)	AN4/AS4	10,000 (690)
NS4	10,000 (690)	RT4	10,000 (690)	AN6/AS6	10,000 (690)
NS6	10,000 (690)	RT6	10,000 (690)	AN8/AS8	10,000 (690)
NS8	10,000 (690)	RT8	10,000 (690)	AN10/AS10	10,000 (690)
NS12	10,000 (690)	RT12	10,000 (690)	AN12/AS12	10,000 (690)
NS16	10,000 (690)	RT16	10,000 (690)	AN16/AS16	10,000 (690)

End Connection	Working Pressure psig (bar)
HM9	30,000 (2068)
HM12	20,000 (1379)
HM14	30,000 (2068)
HM16	20,000 (1379)
HM21	10,000 (690)

Working Temperature

Connection Type	Temperature Range
Male or Female NPT	-325°F to 400°F (-198°C to 204°C)
Male or Female ISO/BSP Tapered	-325°F to 400°F (-198°C to 204°C)
Male or Female JIC (37° Flare)	-423°F to 1200°F (-252°C to 649°C)
Female Swivel JIC (37° Flare)	-423°F to 1200°F (-252°C to 649°C)
Male Type "M"	-423°F to 1200°F (-252°C to 649°C)

Cautions:

- ⦿ Do not loosen or tighten fittings when the system is pressurized.
- ⦿ Always use proper thread sealants on tapered pipe threads.

Ordering Information

The structure of FITOK's type S pipe fittings are the same as standard pipe fittings. To get the complete ordering number of type S pipe fittings, add "-S" as a suffix to the ordering number of standard pipe fittings.

Examples: 3/8" NPT Hex Nipple, the ordering number is : SS-HPHN-NS6-S.

The sizes of type S pipe fittings are the same as standard pipe fittings, please refer to the FITOK catalog *Pipe Fittings* on A-35.

Medium & High Pressure
Fittings and Tubing

Quick Couplings

Medium & High Pressure
Valves

Line Filters

Sour Service Products

Subsea Valves

Tools and Installation
Instructions

Technical Information

Adapters and Couplings

Features

- ⦿ Annealed 316 Stainless Steel as standard material, other materials available upon request
- ⦿ Every fitting marked with size, material and heat number

Working Temperature

Connection Type	Working Temperature Range
Male MP	-325°F to 1200°F (-198°C to 649°C)
Male HP	-325°F to 1200°F (-198°C to 649°C)
Female MP	-325°F to 1200°F (-198°C to 649°C)
Female HP	-325°F to 1200°F (-198°C to 649°C)
MP Nipples	-325°F to 1200°F (-198°C to 649°C)
Nipples	-325°F to 1200°F (-198°C to 649°C)
NPT Pipe Thread	-325°F to 400°F (-198°C to 204°C)
JIC (37°Flare)	-325°F to 1200°F (-198°C to 649°C)
Male Type "M"	-325°F to 1200°F (-198°C to 649°C)

Working Pressure

- ⦿ The working pressures of Adapters and Couplings are dependent on the end connection with the lowest working pressure.
- ⦿ The working pressures of the end connections are shown in the table below .

End Connection	Working Pressure psig (bar)	End Connection	Working Pressure psig (bar)	End Connection	Working Pressure psig (bar)
2MP4/2CP4/2FH4	10,000 (690)	2CT4	10,000 (690)	6MP4/6CP4/6FH4	30,000 (2068)
2MP6/2CP6/2FH6	10,000 (690)	2CT6	10,000 (690)	6MP6/6CP6/6FH6	30,000 (2068)
2MP9/2CP9/2FH9	10,000 (690)	2CT9	10,000 (690)	6MP9/6CP9/6FH9	30,000 (2068)
2MP12/2CP12/2FH12	10,000 (690)	2CT12	10,000 (690)	—	—
2MP16/2CP16/2FH16	10,000 (690)	2CT16	10,000 (690)	—	—

End Connection	Working Pressure psig (bar)	End Connection	Working Pressure psig (bar)	End Connection	Working Pressure psig (bar)	End Connection	Working Pressure psig (bar)
6CT4	30,000 (2068)	NS2	10,000 (690)	AN4	10,000 (690)	HM9	30,000 (2068)
6CT6	30,000 (2068)	NS4	10,000 (690)	AN6	10,000 (690)	HM12	20,000 (1379)
6CT9	30,000 (2068)	NS6	10,000 (690)	AN8	10,000 (690)	HM14	30,000 (2068)
—	—	NS8	10,000 (690)	AN10	10,000 (690)	HM16	20,000 (1379)
—	—	NS12	10,000 (690)	AN12	10,000 (690)	HM21	10,000 (690)
—	—	NS16	10,000 (690)	AN16	10,000 (690)	—	—

Cautions:

- ⦿ Do not loosen or tighten fittings when the system is pressurized.
- ⦿ Always use proper thread sealants on tapered pipe threads.

Ordering Information

FITOK's type S adapters and couplings don't contain "DMP", "DCP" and "DHL" connection, the structure of which are the same as other types of standard adapters and couplings. Add "-S" as a suffix to the ordering number of standard adapters and couplings to get the complete ordering number of type S adapters and couplings. For adapters and couplings with "2FH" or "6FH" connection, if glands and collars are not needed, add "-SWO" as a suffix.

Examples:

1. Adapter, one connection is 2MP9, the other connection is NS8, the ordering number is SS-MMA-2MP9-NS8-S.
2. Coupling, one connection is 6FH6, the other connection is 2FH4, glands and collars are not needed, the ordering number is SS-FFC-6FH6-2FH4-SWO.

The sizes of type S adapters and couplings are the same as standard adapters and couplings, please refer to the FITOK catalog *Adapters and Couplings* on A-66.

Medium & High Pressure
Fittings and Tubing

Quick Couplings

Medium & High Pressure
Valves

Line Filters

Sour Service Products

Subsea Valves

Tools and Installation
Instructions

Technical Information

Needle Valves

Pressures to 30,000 psig (2068 bar)

Features

- ⦿ Annealed 316 Stainless Steel for valve body and Alloy 725 for lower stem
- ⦿ Selected materials of packing gland and upper stem for optimum thread cycle life and reduced handle torque
- ⦿ Metal-to-metal seating achieves ideal shutoff, longer stem/seat service lifetime for abrasive flow, excellent corrosion resistance and greater durability for repeated on/off cycles
- ⦿ Non-rotating stem and bar stock body design
- ⦿ Easy to assemble and replace packing
- ⦿ Packing located under stem threads
- ⦿ Reliable locking for packing gland
- ⦿ Options for Vee or Regulating stem tips
- ⦿ Five flow patterns available

Technical Data

15N Series					
Connection Size	Connection	Orifice in. (mm)	Cv	Working Pressure psig (bar)	Working Temperature Range
1/8" Female NPT	FNS2	0.078 (1.98)	0.11	10,000 (690)	-100°F~400°F (-73°C~204°C)
1/8" Female ISO/BSP Tapered	FRT2				
1/4" Female NPT	FNS4	0.203 (5.16)	0.63	10,000 (690)	
1/4" Female ISO/BSP Tapered	FRT4				
3/8" Female NPT	FNS6	0.219 (5.56)	0.75	10,000 (690)	
3/8" Female ISO/BSP Tapered	FRT6				
1/2" Female NPT	FNS8	0.312 (7.92)	1.30	10,000 (690)	
1/2" Female ISO/BSP Tapered	FRT8				
20N Series					
Tube O.D. in.	Connection	Orifice in. (mm)	Cv	Working Pressure psig (bar)	Working Temperature Range
1/4	2FH4	0.125 (3.18)	0.31	10,000 (690)	-100°F~600°F (-73°C~316°C)
3/8	2FH6	0.204 (5.18)	0.68	10,000 (690)	
9/16	2FH9	0.312 (7.92)	1.30	10,000 (690)	
3/4	2FH12	0.438 (11.13)	2.50	10,000 (690)	
1	2FH16	0.562 (14.27)	4.40	10,000 (690)	

30N Series					
Tube O.D. in.	Connection	Orifice in. (mm)	Cv	Working Pressure psig (bar)	Working Temperature Range
1/4	6FH4	0.094 (2.39)	0.12	20,000 (1379)	-100°F~600°F (-73°C~316°C)
3/8	6FH6	0.125 (3.18)	0.23	20,000 (1379)	
9/16	6FH9	0.125 (3.18)	0.33	20,000 (1379)	
60N Series					
Tube O.D. in.	Connection	Orifice in. (mm)	Cv	Working Pressure psig (bar)	Working Temperature Range
1/4	6FH4	0.063 (1.59)	0.08	30,000 (2068)	-100°F~600°F (-73°C~316°C)
3/8	6FH6	0.063 (1.59)	0.09	30,000 (2068)	
9/16	6FH9	0.078 (1.98)	0.14	30,000 (2068)	

- NOTES: 1. The values of Cv shown are for 2-way straight valve pattern.
 2. The values of Cv for 2-way angle pattern will increase by about 50% (Based on water).
 3. Packing Options
 PTFE is the standard packing material for 15N, 20N and 30N series, RPTFE glass also available.
 Packing material for 60N Series is RPTFE only.
 PTFE: -100°F~450°F (-73°C~232°C)
 RPTFE glass: -100°F~600°F (-73°C~316°C)

Flow Data at 100°F (38°C)

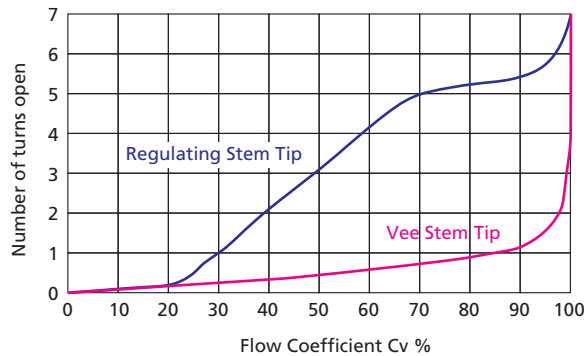

Pressure vs. Temperature Curve

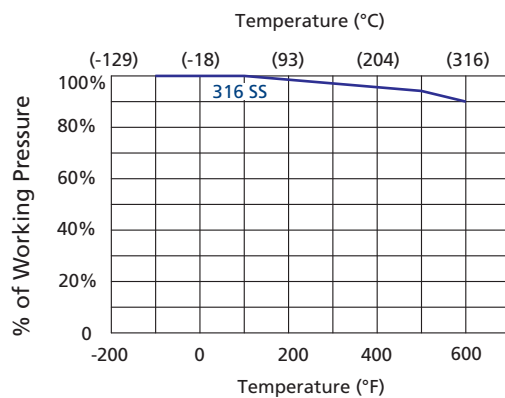

Medium & High Pressure Fittings and Tubing
 Quick Couplings
 Medium & High Pressure Valves
 Line Filters
 Sour Service Products
 Subsea Valves
 Tools and Installation Instructions
 Technical Information

Standard Materials of Construction

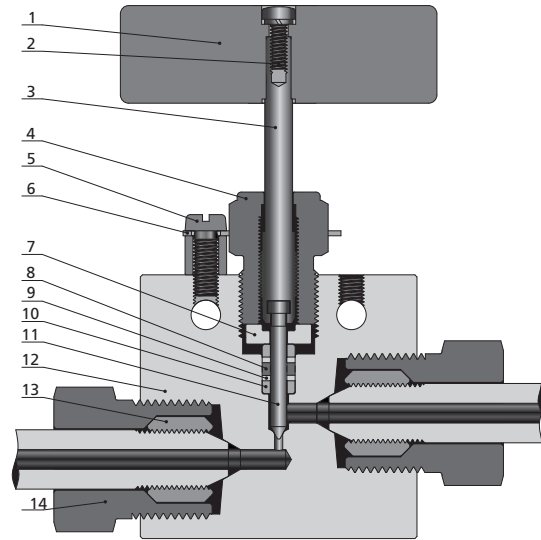

Item	Component	Material Grade/ASTM Specification
1	Handle	Stainless steel
2	Handle Screw	Stainless steel
3	Upper Stem	316 SS/A479
4	Packing Gland	316 SS/A479
5	Locking Screw	Stainless steel
6	Locking Plate	304 SS/A240
7	Packing Ring	316 SS/A479 (For 15N, 20N and 30N Series), S17400/A564 (For 60N Series)
8	<i>Packing</i>	<i>PTFE/RPTFE</i>
9	<i>Retaining Ring</i>	<i>PEEK (For 60N Series Only)</i>
10	<i>Packing Washer</i>	<i>316 SS/A479 (For 15N, 20N and 30N Series), Alloy 725 (For 60N Series)</i>
11	<i>Lower Stem</i>	<i>Alloy 725</i>
12	<i>Body</i>	<i>Annealed 316 SS</i>
13	Collar	Annealed 316 SS/A479 (For tube connections)
14	Gland	Annealed 316 SS/A479 (For tube connections)
	Lubricant	Molybdenum disulfide

Wetted components listed in italics.

Medium & High Pressure Fittings and Tubing
 Quick Couplings
 Medium & High Pressure Valves
 Line Filters
 Sour Service Products
 Subsea Valves
 Tools and Installation Instructions
 Technical Information

Ordering Information and Dimensions (Pipe Connection)

Straight

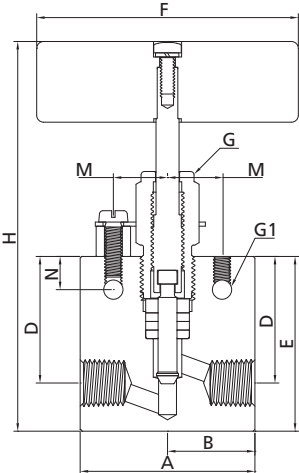

Angle

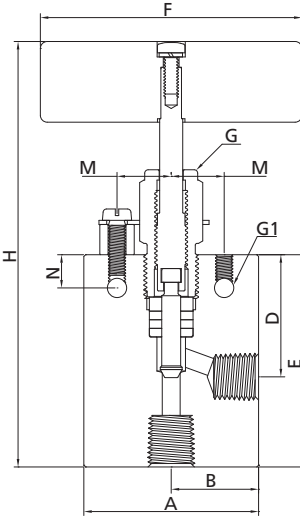

3-way/2 on pressure

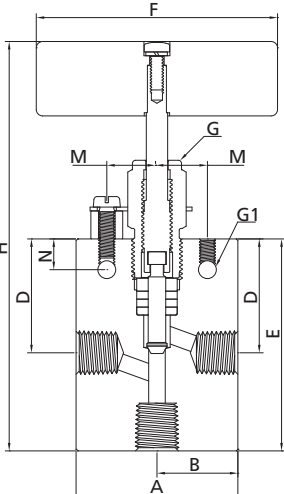

3-way/1 on pressure

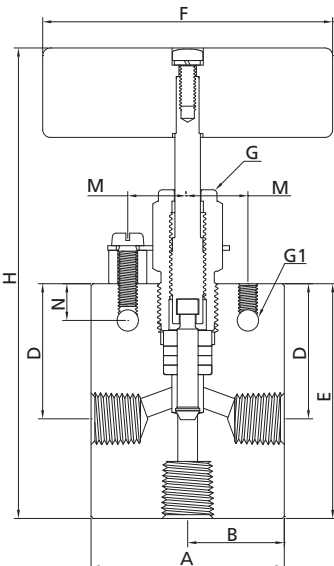

3-way/2 stem manifold

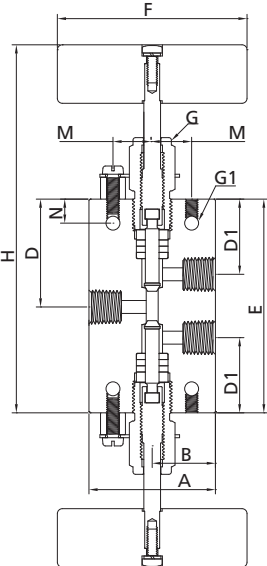

Medium & High Pressure Fittings and Tubing
Quick Couplings
Medium & High Pressure Valves
Line Filters
Sour Service Products
Subsea Valves
Tools and Installation Instructions
Technical Information

Ordering Information and Dimensions (Pipe Connection)

15N Series (Straight)															
Ordering Number	Connection	Orifice in. (mm)	Dimensions, in. (mm)												
			A	B	C	D	D1	E	F	G	G1	H	M	N	Thickness
15NSS-FNS2-1-S	FNS2	0.078 (1.98)	1.50 (38.1)	0.75 (19.1)	/	0.81 (20.6)	/	1.25 (31.8)	1.75 (44.5)	0.62 (15.8)	0.17 (4.3)	3.00 (76.4)	0.56 (14.2)	0.31 (7.9)	0.63 (15.9)
15NSS-FRT2-1-S	FRT2														
15NSS-FNS4-1-S	FNS4	0.203 (5.2)	2.00 (50.8)	1.00 (25.4)	/	1.41 (35.8)	/	2.00 (50.8)	3.00 (76.2)	0.75 (19.1)	0.22 (5.6)	4.89 (124.1)	0.62 (15.8)	0.38 (9.7)	0.75 (19.1)
15NSS-FRT4-1-S	FRT4														
15NSS-FNS6-1-S	FNS6	0.219 (5.56)	2.50 (63.5)	1.25 (31.8)	/	1.41 (35.8)	/	2.00 (50.8)	3.00 (76.2)	0.75 (19.1)	0.22 (5.6)	4.85 (123.1)	0.62 (15.8)	0.38 (9.7)	1.00 (25.4)
15NSS-FRT6-1-S	FRT6														
15NSS-FNS8-1-S	FNS8	0.312 (7.92)	3.00 (76.2)	1.50 (38.1)	/	2.06 (52.3)	/	2.88 (73.2)	4.00 (101.6)	1.00 (25.4)	0.34 (8.6)	6.18 (157.2)	0.69 (17.5)	0.50 (12.7)	1.38 (35.1)
15NSS-FRT8-1-S	FRT8														

15N Series (Angle)															
Ordering Number	Connection	Orifice in. (mm)	Dimensions, in. (mm)												
			A	B	C	D	D1	E	F	G	G1	H	M	N	Thickness
15NSS-FNS2-2-S	FNS2	0.078 (1.98)	1.50 (38.1)	0.75 (19.1)	/	0.81 (20.6)	/	1.38 (34.9)	1.75 (44.5)	0.62 (15.8)	0.17 (4.3)	3.13 (79.5)	0.56 (14.2)	0.31 (7.9)	0.63 (15.9)
15NSS-FRT2-2-S	FRT2														
15NSS-FNS4-2-S	FNS4	0.203 (5.2)	2.00 (50.8)	1.00 (25.4)	/	1.41 (35.8)	/	2.44 (62.0)	3.00 (76.2)	0.75 (19.1)	0.22 (5.6)	5.33 (135.4)	0.62 (15.8)	0.38 (9.7)	0.75 (19.1)
15NSS-FRT4-2-S	FRT4														
15NSS-FNS6-2-S	FNS6	0.219 (5.56)	2.50 (63.5)	1.25 (31.8)	/	1.41 (35.8)	/	2.44 (62.0)	3.00 (76.2)	0.75 (19.1)	0.22 (5.6)	5.34 (135.7)	0.62 (15.8)	0.38 (9.7)	1.00 (25.4)
15NSS-FRT6-2-S	FRT6														
15NSS-FNS8-2-S	FNS8	0.312 (7.92)	3.00 (76.2)	1.50 (38.1)	/	2.06 (52.3)	/	3.38 (85.9)	4.00 (101.6)	1.00 (25.4)	0.34 (8.6)	6.69 (169.9)	0.69 (17.5)	0.50 (12.7)	1.38 (35.1)
15NSS-FRT8-2-S	FRT8														

15N Series (3-way/2 on pressure)															
Ordering Number	Connection	Orifice in. (mm)	Dimensions, in. (mm)												
			A	B	C	D	D1	E	F	G	G1	H	M	N	Thickness
15NSS-FNS2-4-S	FNS2	0.078 (1.98)	1.50 (38.1)	0.75 (19.1)	/	0.81 (20.6)	/	1.57 (40.0)	1.75 (44.5)	0.62 (15.8)	0.17 (4.3)	3.33 (84.6)	0.56 (14.2)	0.31 (7.9)	0.63 (15.9)
15NSS-FRT2-4-S	FRT2														
15NSS-FNS4-4-S	FNS4	0.203 (5.2)	2.00 (50.8)	1.00 (25.4)	/	1.41 (35.8)	/	2.62 (66.6)	3.00 (76.2)	0.75 (19.1)	0.22 (5.6)	5.51 (140.0)	0.62 (15.8)	0.38 (9.7)	0.75 (19.1)
15NSS-FRT4-4-S	FRT4														
15NSS-FNS6-4-S	FNS6	0.219 (5.56)	2.50 (63.5)	1.25 (31.8)	/	1.41 (35.8)	/	2.62 (66.6)	3.00 (76.2)	0.75 (19.1)	0.22 (5.6)	5.47 (138.9)	0.62 (15.8)	0.38 (9.7)	1.00 (25.4)
15NSS-FRT6-4-S	FRT6														
15NSS-FNS8-4-S	FNS8	0.312 (7.92)	3.00 (76.2)	1.50 (38.1)	/	2.06 (52.3)	/	3.62 (92.0)	4.00 (101.6)	1.00 (25.4)	0.34 (8.6)	6.94 (176.2)	0.69 (17.5)	0.50 (12.7)	1.38 (35.1)
15NSS-FRT8-4-S	FRT8														

Medium & High Pressure Fittings and Tubing
Quick Couplings
Medium & High Pressure Valves
Line Filters
Sour Service Products
Subsea Valves
Tools and Installation Instructions
Technical Information

Ordering Information and Dimensions (Pipe Connection)

15N Series (3-way/1 on pressure)															
Ordering Number	Connection	Orifice in. (mm)	Dimensions, in. (mm)												
			A	B	C	D	D1	E	F	G	G1	H	M	N	Thickness
15NSS-FNS2-5-S	FNS2	0.078 (1.98)	1.50	0.75	/	0.81	/	1.38	1.75	0.62	0.17	3.13	0.56	0.31	0.63
15NSS-FRT2-5-S	FRT2		(38.1)	(19.1)		(20.6)		(35.0)	(44.5)	(15.8)	(4.3)	(79.5)	(14.2)	(7.9)	(15.9)
15NSS-FNS4-5-S	FNS4	0.203 (5.2)	2.00	1.00	/	1.41	/	2.44	3.00	0.75	0.22	5.33	0.62	0.38	0.75
15NSS-FRT4-5-S	FRT4		(50.8)	(25.4)		(35.8)		(62.0)	(76.2)	(19.1)	(5.6)	(135.4)	(15.8)	(9.7)	(19.1)
15NSS-FNS6-5-S	FNS6	0.219 (5.56)	2.50	1.25	/	1.41	/	2.44	3.00	0.75	0.22	5.34	0.62	0.38	1.00
15NSS-FRT6-5-S	FRT6		(63.5)	(31.8)		(35.8)		(62.0)	(76.2)	(19.1)	(5.6)	(135.7)	(15.8)	(9.7)	(25.4)
15NSS-FNS8-5-S	FNS8	0.312 (7.92)	3.00	1.50	/	2.06	/	3.38	4.00	1.00	0.34	6.69	0.69	0.50	1.38
15NSS-FRT8-5-S	FRT8		(76.2)	(38.1)		(52.3)		(85.9)	(101.6)	(25.4)	(8.6)	(169.9)	(17.5)	(12.7)	(35.1)

15N Series (3-way/2 stem manifold)															
Ordering Number	Connection	Orifice in. (mm)	Dimensions, in. (mm)												
			A	B	C	D	D1	E	F	G	G1	H	M	N	Thickness
15NSS-FNS2-6-S	FNS2	0.078 (1.98)	1.50	0.75	/	1.00	0.68	2.02	1.75	0.62	0.17	3.77	0.56	0.31	0.63
15NSS-FRT2-6-S	FRT2		(38.1)	(19.1)		(25.6)	(17.2)	(51.2)	(44.5)	(15.8)	(4.3)	(95.8)	(14.2)	(7.9)	(15.9)
15NSS-FNS4-6-S	FNS4	0.203 (5.2)	2.00	1.00	/	1.69	1.19	3.38	3.00	0.75	0.22	6.27	0.62	0.38	0.75
15NSS-FRT4-6-S	FRT4		(50.8)	(25.4)		(42.9)	(30.2)	(85.9)	(76.2)	(19.1)	(5.6)	(159.2)	(15.8)	(9.7)	(19.1)
15NSS-FNS6-6-S	FNS6	0.219 (5.56)	2.50	1.25	/	1.69	1.19	3.38	3.00	0.75	0.22	6.22	0.62	0.38	1.00
15NSS-FRT6-6-S	FRT6		(63.5)	(31.8)		(42.9)	(30.2)	(85.9)	(76.2)	(19.1)	(5.6)	(158.1)	(15.8)	(9.7)	(25.4)
15NSS-FNS8-6-S	FNS8	0.312 (7.92)	3.00	1.50	/	2.56	1.75	5.12	4.00	1.00	0.34	8.43	0.69	0.50	1.38
15NSS-FRT8-6-S	FRT8		(76.2)	(38.1)		(65.1)	(44.5)	(130.1)	(101.6)	(25.4)	(8.6)	(214.2)	(17.5)	(12.7)	(35.1)

- NOTES: 1. G is the drill dimension of packing gland mounting hole.
 2. G1 is the dimension of bracket mounting hole.
 3. panel mounting drill size: 0.25" all valves.
 4. H is the dimension of stem in closed position.
 5. All dimensions for reference only and subject to change. For dimensions not shown above, please contact FITOK group or our authorized distributors.

Medium & High Pressure
Fittings and Tubing

Quick Couplings

Medium & High Pressure
Valves

Line Filters

Sour Service Products

Subsea Valves

Tools and Installation
Instructions

Technical Information

Ordering Information and Dimensions (Tubing Connection)

Medium & High Pressure Fittings and Tubing
Quick Couplings
Medium & High Pressure Valves
Line Filters
Sour Service Products
Subsea Valves
Tools and Installation Instructions
Technical Information

Straight

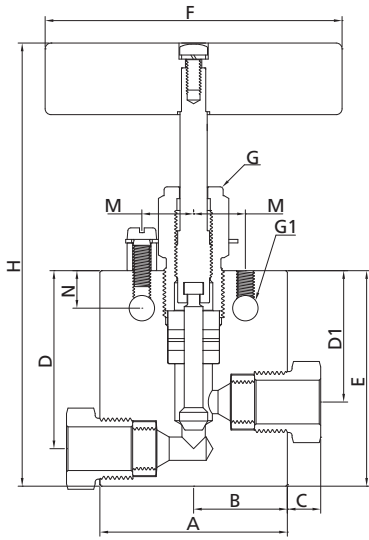

Angle

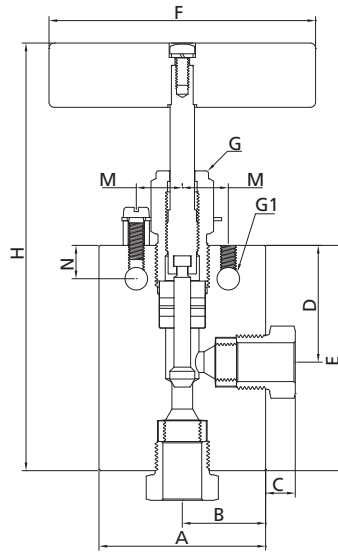

Angle (replaceable seat)

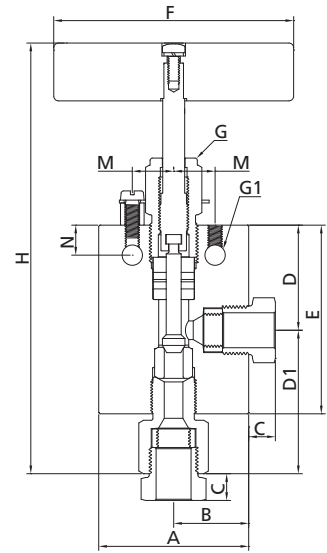

3-way/2 on pressure

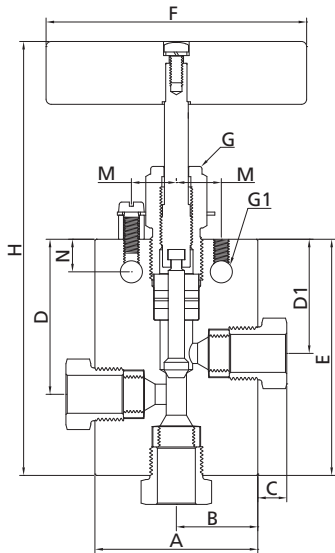

3-way/1 on pressure

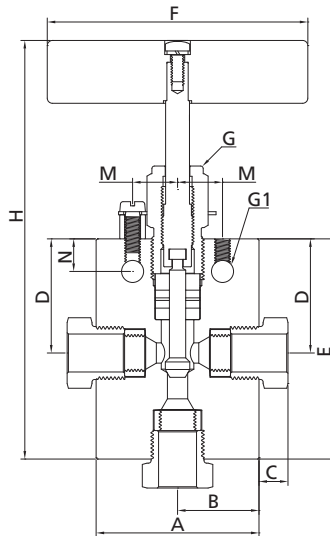

3-way/2 stem manifold

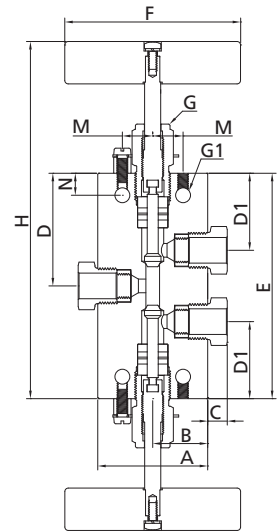

Ordering Information and Dimensions (Tubing Connection)

20N Series (Straight)															
Ordering Number	Connection	Orifice in. (mm)	Dimensions, in. (mm)												
			A	B	C	D	D1	E	F	G	G1	H	M	N	Thickness
20NSS-2FH4-1-S	2FH4	0.125 (3.18)	2.00 (50.8)	1.00 (25.4)	0.38 (9.7)	1.62 (41.2)	1.19 (30.2)	2.00 (50.8)	3.00 (76.2)	0.75 (19.1)	0.22 (5.6)	4.85 (123.1)	0.62 (15.8)	0.38 (9.7)	0.75 (19.1)
20NSS-2FH6-1-S	2FH6	0.204 (5.18)	2.00 (50.8)	1.00 (25.4)	0.44 (11.2)	1.62 (41.2)	1.19 (30.2)	2.00 (50.8)	3.00 (76.2)	0.75 (19.1)	0.22 (5.6)	4.89 (124.2)	0.62 (15.8)	0.38 (9.7)	0.75 (19.1)
20NSS-2FH9-1-S	2FH9	0.312 (7.92)	2.50 (63.5)	1.25 (31.8)	0.55 (14.0)	2.37 (60.3)	1.75 (44.5)	2.88 (73.2)	4.00 (101.6)	1.00 (25.4)	0.34 (8.6)	6.18 (157.2)	0.69 (17.5)	0.50 (12.7)	1.00 (25.4)
20NSS-2FH12-1-S	2FH12	0.438 (11.13)	3.00 (76.2)	1.50 (38.1)	0.60 (15.2)	3.00 (76.2)	2.25 (57.2)	3.75 (95.3)	10.25 (260.4)	1.19 (30.2)	0.44 (11.2)	7.37 (187.2)	0.88 (22.4)	0.63 (16.0)	1.38 (35.1)
20NSS-2FH16-1-S	2FH16	0.562 (14.27)	4.12 (104.6)	2.06 (52.3)	0.74 (18.7)	3.75 (95.3)	2.81 (71.4)	4.63 (117.6)	10.25 (260.4)	1.62 (41.2)	0.56 (14.2)	9.45 (240.1)	1.25 (31.8)	1.13 (28.7)	1.75 (44.5)

20N Series (Angle)															
Ordering Number	Connection	Orifice in. (mm)	Dimensions, in. (mm)												
			A	B	C	D	D1	E	F	G	G1	H	M	N	Thickness
20NSS-2FH4-2-S	2FH4	0.125 (3.18)	2.00 (50.8)	1.00 (25.4)	0.38 (9.7)	1.19 (30.2)	/	2.44 (61.9)	3.00 (76.2)	0.75 (19.1)	0.22 (5.6)	5.28 (134.2)	0.62 (15.8)	0.38 (9.7)	0.75 (19.1)
20NSS-2FH6-2-S	2FH6	0.204 (5.18)	2.00 (50.8)	1.00 (25.4)	0.44 (11.2)	1.19 (30.2)	/	2.44 (61.9)	3.00 (76.2)	0.75 (19.1)	0.22 (5.6)	5.33 (135.4)	0.62 (15.8)	0.38 (9.7)	0.75 (19.1)
20NSS-2FH9-2-S	2FH9	0.312 (7.92)	2.50 (63.5)	1.25 (31.8)	0.55 (14.0)	1.75 (44.5)	/	3.38 (85.9)	4.00 (101.6)	1.00 (25.4)	0.34 (8.6)	6.69 (170.0)	0.69 (17.5)	0.50 (12.7)	1.00 (25.4)
20NSS-2FH12-2-S	2FH12	0.438 (11.13)	3.00 (76.2)	1.50 (38.1)	0.60 (15.2)	2.25 (57.2)	/	4.25 (108.0)	10.25 (260.4)	1.19 (30.2)	0.44 (11.2)	7.87 (199.9)	0.88 (22.4)	0.63 (16.0)	1.38 (35.1)
20NSS-2FH16-2-S	2FH16	0.562 (14.27)	4.12 (104.6)	2.06 (52.3)	0.74 (18.7)	2.81 (71.4)	/	5.12 (130.1)	10.25 (260.4)	1.62 (41.2)	0.56 (14.2)	9.94 (252.6)	1.25 (31.8)	1.13 (28.7)	1.75 (44.5)

20N Series (Angle/replaceable seat)															
Ordering Number	Connection	Orifice in. (mm)	Dimensions, in. (mm)												
			A	B	C	D	D1	E	F	G	G1	H	M	N	Thickness
20NSS-2FH4-3-S	2FH4	0.125 (3.18)	2.00 (50.8)	1.00 (25.4)	0.38 (9.7)	1.19 (30.2)	2.13 (54.0)	2.25 (57.2)	3.00 (76.2)	0.75 (19.1)	0.22 (5.6)	6.10 (154.9)	0.62 (15.8)	0.38 (9.7)	0.75 (19.1)
20NSS-2FH6-3-S	2FH6	0.204 (5.18)	2.00 (50.8)	1.00 (25.4)	0.44 (11.2)	1.19 (30.2)	2.13 (54.0)	2.25 (57.2)	3.00 (76.2)	0.75 (19.1)	0.22 (5.6)	6.16 (156.5)	0.62 (15.8)	0.38 (9.7)	0.75 (19.1)
20NSS-2FH9-3-S	2FH9	0.312 (7.92)	2.50 (63.5)	1.25 (31.8)	0.55 (14.0)	1.75 (44.5)	2.50 (63.5)	3.13 (79.4)	4.00 (101.6)	1.00 (25.4)	0.34 (8.6)	7.58 (192.1)	0.69 (17.5)	0.50 (12.7)	1.00 (25.4)
20NSS-2FH12-3-S	2FH12	0.438 (11.13)	3.00 (76.2)	1.50 (38.1)	0.60 (15.2)	2.25 (57.2)	3.44 (87.4)	4.25 (108.0)	10.25 (260.4)	1.19 (30.2)	0.44 (11.2)	9.30 (236.3)	0.88 (22.4)	0.63 (16.0)	1.38 (35.1)
20NSS-2FH16-3-S	2FH16	0.562 (14.27)	4.12 (104.6)	2.06 (52.3)	0.74 (18.7)	2.81 (71.4)	4.22 (107.4)	5.25 (133.4)	10.25 (260.4)	1.62 (41.2)	0.56 (14.2)	11.86 (301.3)	1.25 (31.8)	1.13 (28.7)	1.75 (44.5)

Medium & High Pressure Fittings and Tubing

Quick Couplings

Medium & High Pressure Valves

Medium & High Pressure

Line Filters

Sour Service Products

Subsea Valves

Tools and Installation Instructions

Technical Information

Ordering Information and Dimensions (Tubing Connection)

20N Series (3-way/2 on pressure)															
Ordering Number	Connection	Orifice in. (mm)	Dimensions, in. (mm)												
			A	B	C	D	D1	E	F	G	G1	H	M	N	Thickness
20NSS-2FH4-4-S	2FH4	0.125 (3.18)	2.00 (50.8)	1.00 (25.4)	0.38 (9.7)	1.63 (41.3)	1.19 (30.2)	2.63 (66.7)	3.00 (76.2)	0.75 (19.1)	0.22 (5.6)	5.47 (139.0)	0.62 (15.8)	0.38 (9.7)	0.75 (19.1)
20NSS-2FH6-4-S	2FH6	0.204 (5.18)	2.00 (50.8)	1.00 (25.4)	0.44 (11.2)	1.63 (41.3)	1.19 (30.2)	2.63 (66.7)	3.00 (76.2)	0.75 (19.1)	0.22 (5.6)	5.52 (140.1)	0.62 (15.8)	0.38 (9.7)	0.75 (19.1)
20NSS-2FH9-4-S	2FH9	0.312 (7.92)	2.50 (63.5)	1.25 (31.8)	0.55 (14.0)	2.37 (60.3)	1.75 (44.5)	3.63 (92.1)	4.00 (101.6)	1.00 (25.4)	0.34 (8.6)	6.94 (176.3)	0.69 (17.5)	0.50 (12.7)	1.00 (25.4)
20NSS-2FH12-4-S	2FH12	0.438 (11.13)	3.00 (76.2)	1.50 (38.1)	0.60 (15.2)	3.00 (76.2)	2.25 (57.2)	4.63 (117.5)	10.25 (260.4)	1.19 (30.2)	0.44 (11.2)	8.24 (209.4)	0.88 (22.4)	0.63 (16.0)	1.38 (35.1)
20NSS-2FH16-4-S	2FH16	0.562 (14.27)	4.12 (104.6)	2.06 (52.3)	0.74 (18.7)	3.75 (95.3)	2.81 (71.4)	5.88 (149.4)	10.25 (260.4)	1.62 (41.2)	0.56 (14.2)	10.70 (271.9)	1.25 (31.8)	1.13 (28.7)	1.75 (44.5)

20N Series (3-way/1 on pressure)															
Ordering Number	Connection	Orifice in. (mm)	Dimensions, in. (mm)												
			A	B	C	D	D1	E	F	G	G1	H	M	N	Thickness
20NSS-2FH4-5-S	2FH4	0.125 (3.18)	2.00 (50.8)	1.00 (25.4)	0.38 (9.7)	1.19 (30.2)		2.44 (61.9)	3.00 (76.2)	0.75 (19.1)	0.22 (5.6)	5.28 (134.2)	0.62 (15.8)	0.38 (9.7)	0.75 (19.1)
20NSS-2FH6-5-S	2FH6	0.204 (5.18)	2.00 (50.8)	1.00 (25.4)	0.44 (11.2)	1.19 (30.2)		2.44 (61.9)	3.00 (76.2)	0.75 (19.1)	0.22 (5.6)	5.33 (135.4)	0.62 (15.8)	0.38 (9.7)	0.75 (19.1)
20NSS-2FH9-5-S	2FH9	0.312 (7.92)	2.50 (63.5)	1.25 (31.8)	0.55 (14.0)	1.75 (44.5)		3.38 (85.9)	4.00 (101.6)	1.00 (25.4)	0.34 (8.6)	6.69 (170.0)	0.69 (17.5)	0.50 (12.7)	1.00 (25.4)
20NSS-2FH12-5-S	2FH12	0.438 (11.13)	3.00 (76.2)	1.50 (38.1)	0.60 (15.2)	2.25 (57.2)		4.25 (108.0)	10.25 (260.4)	1.19 (30.2)	0.44 (11.2)	7.87 (199.9)	0.88 (22.4)	0.63 (16.0)	1.38 (35.1)
20NSS-2FH16-5-S	2FH16	0.562 (14.27)	4.12 (104.6)	2.06 (52.3)	0.74 (18.7)	2.81 (71.4)		5.12 (130.1)	10.25 (260.4)	1.62 (41.2)	0.56 (14.2)	9.94 (252.6)	1.25 (31.8)	1.13 (28.7)	1.75 (44.5)

20N Series (3-way/2 stem manifold)															
Ordering Number	Connection	Orifice in. (mm)	Dimensions, in. (mm)												
			A	B	C	D	D1	E	F	G	G1	H	M	N	Thickness
20NSS-2FH4-6-S	2FH4	0.125 (3.18)	2.00 (50.8)	1.00 (25.4)	0.38 (9.7)	1.69 (42.9)	1.19 (30.2)	3.38 (85.7)	3.00 (76.2)	0.75 (19.1)	0.22 (5.6)	6.23 (158.1)	0.62 (15.8)	0.38 (9.7)	0.75 (19.1)
20NSS-2FH6-6-S	2FH6	0.204 (5.18)	2.00 (50.8)	1.00 (25.4)	0.44 (11.2)	1.69 (42.9)	1.19 (30.2)	3.38 (85.7)	3.00 (76.2)	0.75 (19.1)	0.22 (5.6)	6.24 (158.6)	0.62 (15.8)	0.38 (9.7)	0.75 (19.1)
20NSS-2FH9-6-S	2FH9	0.312 (7.92)	2.50 (63.5)	1.25 (31.8)	0.55 (14.0)	2.56 (65.1)	1.75 (44.5)	5.13 (130.2)	4.00 (101.6)	1.00 (25.4)	0.34 (8.6)	8.44 (214.4)	0.69 (17.5)	0.50 (12.7)	1.00 (25.4)
20NSS-2FH12-6-S	2FH12	0.438 (11.13)	3.00 (76.2)	1.50 (38.1)	0.60 (15.2)	3.00 (76.2)	2.25 (57.2)	6.50 (165.1)	10.25 (260.4)	1.19 (30.2)	0.44 (11.2)	10.11 (257.0)	0.88 (22.4)	0.63 (16.0)	1.38 (35.1)
20NSS-2FH16-6-S	2FH16	0.562 (14.27)	4.12 (104.6)	2.06 (52.3)	0.74 (18.7)	3.75 (95.3)	2.81 (71.4)	7.50 (190.5)	10.25 (260.4)	1.62 (41.2)	0.56 (14.2)	12.32 (313.0)	1.25 (31.8)	1.13 (28.7)	1.75 (44.5)

Medium & High Pressure Fittings and Tubing
Quick Couplings
Medium & High Pressure Valves
Line Filters
Sour Service Products
Subsea Valves
Tools and Installation Instructions
Technical Information

Ordering Information and Dimensions (Tubing Connection)

30N Series (Straight)															
Ordering Number	Connection	Orifice in. (mm)	Dimensions, in. (mm)												
			A	B	C	D	D1	E	F	G	G1	H	M	N	Thickness
30NSS-6FH4-1-S	6FH4	0.094 (2.39)	2.00 (50.8)	1.00 (25.4)	0.47 (11.9)	1.50 (38.1)	1.12 (28.5)	2.00 (50.8)	3.00 (76.2)	1.00 (25.4)	0.22 (5.6)	4.69 (119.1)	0.69 (17.5)	0.38 (9.7)	1.00 (25.4)
30NSS-6FH6-1-S	6FH6	0.125 (3.18)	2.00 (50.8)	1.00 (25.4)	0.61 (15.6)	1.50 (38.1)	1.12 (28.5)	2.00 (50.8)	3.00 (76.2)	1.00 (25.4)	0.22 (5.6)	4.69 (119.1)	0.69 (17.5)	0.38 (9.7)	1.00 (25.4)
30NSS-6FH9-1-S	6FH9	0.125 (3.18)	2.62 (66.6)	1.31 (33.3)	0.95 (24.1)	1.56 (39.6)	1.12 (28.5)	2.44 (62.0)	3.00 (76.2)	1.00 (25.4)	0.28 (7.1)	5.13 (130.3)	0.69 (17.5)	0.38 (9.7)	1.50 (38.1)

30N Series (Angle)															
Ordering Number	Connection	Orifice in. (mm)	Dimensions, in. (mm)												
			A	B	C	D	D1	E	F	G	G1	H	M	N	Thickness
30NSS-6FH4-2-S	6FH4	0.094 (2.39)	2.00 (50.8)	1.00 (25.4)	0.47 (11.9)	1.12 (28.5)	/	2.00 (50.8)	3.00 (76.2)	1.00 (25.4)	0.22 (5.6)	4.69 (119.1)	0.69 (17.5)	0.38 (9.7)	1.00 (25.4)
30NSS-6FH6-2-S	6FH6	0.125 (3.18)	2.00 (50.8)	1.00 (25.4)	0.61 (15.6)	1.12 (28.5)	/	2.25 (57.2)	3.00 (76.2)	1.00 (25.4)	0.22 (5.6)	4.95 (125.7)	0.69 (17.5)	0.38 (9.7)	1.00 (25.4)
30NSS-6FH9-2-S	6FH9	0.125 (3.18)	2.62 (66.6)	1.31 (33.3)	0.95 (24.1)	1.12 (28.5)	/	2.44 (62.0)	3.00 (76.2)	1.00 (25.4)	0.28 (7.1)	5.13 (130.3)	0.69 (17.5)	0.38 (9.7)	1.50 (38.1)

30N Series (Angle/replaceable seat)															
Ordering Number	Connection	Orifice in. (mm)	Dimensions, in. (mm)												
			A	B	C	D	D1	E	F	G	G1	H	M	N	Thickness
30NSS-6FH4-3-S	6FH4	0.094 (2.39)	2.00 (50.8)	1.00 (25.4)	0.47 (11.9)	1.12 (28.5)	2.06 (52.3)	2.38 (60.5)	3.00 (76.2)	1.00 (25.4)	0.22 (5.6)	5.88 (149.2)	0.69 (17.5)	0.38 (9.7)	1.00 (25.4)
30NSS-6FH6-3-S	6FH6	0.125 (3.18)	2.00 (50.8)	1.00 (25.4)	0.61 (15.6)	1.12 (28.5)	2.31 (58.67)	2.38 (60.5)	3.00 (76.2)	1.00 (25.4)	0.22 (5.6)	6.12 (155.4)	0.69 (17.5)	0.38 (9.7)	1.00 (25.4)
30NSS-6FH9-3-S	6FH9	0.125 (3.18)	2.62 (66.6)	1.31 (33.3)	0.95 (24.1)	1.12 (28.6)	2.55 (65.0)	2.44 (62.0)	3.00 (76.2)	1.00 (25.4)	0.28 (7.1)	6.39 (162.4)	0.69 (17.5)	0.38 (9.7)	1.50 (38.1)

30N Series (3-way/2 on pressure)															
Ordering Number	Connection	Orifice in. (mm)	Dimensions, in. (mm)												
			A	B	C	D	D1	E	F	G	G1	H	M	N	Thickness
30NSS-6FH4-4-S	6FH4	0.094 (2.39)	2.00 (50.8)	1.00 (25.4)	0.47 (11.9)	1.50 (38.1)	1.12 (28.5)	2.12 (53.9)	3.00 (76.2)	1.00 (25.4)	0.22 (5.6)	4.81 (122.1)	0.69 (17.5)	0.38 (9.7)	1.00 (25.4)
30NSS-6FH6-4-S	6FH6	0.125 (3.18)	2.00 (50.8)	1.00 (25.4)	0.61 (15.6)	1.50 (38.1)	1.12 (28.5)	2.50 (63.5)	3.00 (76.2)	1.00 (25.4)	0.22 (5.6)	5.19 (131.9)	0.69 (17.5)	0.38 (9.7)	1.00 (25.4)
30NSS-6FH9-4-S	6FH9	0.125 (3.18)	2.62 (66.6)	1.31 (33.3)	0.95 (24.1)	1.56 (39.6)	1.12 (28.5)	2.88 (73.2)	3.00 (76.2)	1.00 (25.4)	0.28 (7.1)	5.57 (141.5)	0.69 (17.5)	0.38 (9.7)	1.50 (38.1)

Medium & High Pressure Fittings and Tubing

Quick Couplings

Medium & High Pressure Valves

Line Filters

Sour Service Products

Subsea Valves

Tools and Installation Instructions

Technical Information

Ordering Information and Dimensions (Tubing Connection)

30N Series (3-way/1 on pressure)

Ordering Number	Connection	Orifice in. (mm)	Dimensions, in. (mm)												
			A	B	C	D	D1	E	F	G	G1	H	M	N	Thickness
30NSS-6FH4-5-S	6FH4	0.094 (2.39)	2.00 (50.8)	1.00 (25.4)	0.47 (11.9)	1.12 (28.5)		2.00 (50.8)	3.00 (76.2)	1.00 (25.4)	0.22 (5.6)	4.69 (119.1)	0.69 (17.5)	0.38 (9.7)	1.00 (25.4)
30NSS-6FH6-5-S	6FH6	0.125 (3.18)	2.00 (50.8)	1.00 (25.4)	0.61 (15.6)	1.12 (28.5)		2.25 (57.2)	3.00 (76.2)	1.00 (25.4)	0.22 (5.6)	4.95 (125.7)	0.69 (17.5)	0.38 (9.7)	1.00 (25.4)
30NSS-6FH9-5-S	6FH9	0.125 (3.18)	2.62 (66.6)	1.31 (33.3)	0.95 (24.1)	1.12 (28.5)		2.44 (62.0)	3.00 (76.2)	1.00 (25.4)	0.28 (7.1)	5.13 (130.3)	0.69 (17.5)	0.38 (9.7)	1.50 (38.1)

30N Series (3-way/2 stem manifold)

Ordering Number	Connection	Orifice in. (mm)	Dimensions, in. (mm)												
			A	B	C	D	D1	E	F	G	G1	H	M	N	Thickness
30NSS-6FH4-6-S	6FH4	0.094 (2.39)	2.00 (50.8)	1.00 (25.4)	0.47 (11.9)	1.53 (38.9)	1.12 (28.5)	3.06 (77.7)	3.00 (76.2)	1.00 (25.4)	0.22 (5.6)	5.75 (146.0)	0.69 (17.5)	0.38 (9.7)	1.00 (25.4)
30NSS-6FH6-6-S	6FH6	0.125 (3.18)	2.00 (50.8)	1.00 (25.4)	0.61 (15.6)	1.62 (41.2)	1.12 (28.5)	3.25 (82.6)	3.00 (76.2)	1.00 (25.4)	0.22 (5.6)	5.94 (150.9)	0.69 (17.5)	0.38 (9.7)	1.00 (25.4)
30NSS-6FH9-6-S	6FH9	0.125 (3.18)	2.62 (66.6)	1.31 (33.3)	0.95 (24.1)	1.88 (47.8)	1.12 (28.5)	3.75 (95.3)	3.00 (76.2)	1.00 (25.4)	0.28 (7.1)	6.44 (163.6)	0.69 (17.5)	0.38 (9.7)	1.50 (38.1)

60N Series (Straight)

Ordering Number	Connection	Orifice in. (mm)	Dimensions, in. (mm)												
			A	B	C	D	D1	E	F	G	G1	H	M	N	Thickness
60NSS-6FH4-TG1-S	6FH4	0.063 (1.59)	2.00 (50.8)	1.00 (25.4)	0.47 (11.9)	1.69 (42.9)	1.31 (33.3)	2.13 (54.0)	3.00 (76.2)	1.00 (25.4)	0.22 (5.6)	4.77 (121.1)	0.69 (17.5)	0.38 (9.7)	1.00 (25.4)
60NSS-6FH6-TG1-S	6FH6	0.063 (1.59)	2.00 (50.8)	1.00 (25.4)	0.61 (15.6)	1.69 (42.9)	1.31 (33.3)	2.25 (57.2)	3.00 (76.2)	1.00 (25.4)	0.22 (5.6)	4.89 (124.3)	0.69 (17.5)	0.38 (9.7)	1.00 (25.4)
60NSS-6FH9-TG1-S	6FH9	0.078 (1.98)	2.62 (66.6)	1.31 (33.3)	0.95 (24.1)	1.75 (44.5)	1.31 (33.3)	2.50 (63.5)	3.00 (76.2)	1.00 (25.4)	0.28 (7.1)	5.14 (130.6)	0.69 (17.5)	0.38 (9.7)	1.50 (38.1)

60N Series (Angle)

Ordering Number	Connection	Orifice in. (mm)	Dimensions, in. (mm)												
			A	B	C	D	D1	E	F	G	G1	H	M	N	Thickness
60NSS-6FH4-TG2-S	6FH4	0.063 (1.59)	2.00 (50.8)	1.00 (25.4)	0.47 (11.9)	1.31 (33.3)		2.38 (60.5)	3.00 (76.2)	1.00 (25.4)	0.22 (5.6)	5.02 (127.5)	0.69 (17.5)	0.38 (9.7)	1.00 (25.4)
60NSS-6FH6-TG2-S	6FH6	0.063 (1.59)	2.00 (50.8)	1.00 (25.4)	0.61 (15.6)	1.31 (33.3)		2.62 (66.6)	3.00 (76.2)	1.00 (25.4)	0.22 (5.6)	5.26 (133.5)	0.69 (17.5)	0.38 (9.7)	1.00 (25.4)
60NSS-6FH9-TG2-S	6FH9	0.078 (1.98)	2.62 (66.6)	1.31 (33.3)	0.95 (24.1)	1.31 (33.3)		2.81 (71.4)	3.00 (76.2)	1.00 (25.4)	0.28 (7.1)	5.45 (138.5)	0.69 (17.5)	0.38 (9.7)	1.50 (38.1)

Ordering Information and Dimensions (Tubing Connection)

60N Series (Angle/replaceable seat)															
Ordering Number	Connection	Orifice in. (mm)	Dimensions, in. (mm)												
			A	B	C	D	D1	E	F	G	G1	H	M	N	Thickness
60NSS-6FH4-TG3-S	6FH4	0.063 (1.59)	2.00 (50.8)	1.00 (25.4)	0.47 (11.9)	1.31 (33.3)	2.12 (53.9)	2.62 (66.6)	3.00 (76.2)	1.00 (25.4)	0.22 (5.6)	6.07 (154.1)	0.69 (17.5)	0.38 (9.7)	1.00 (25.4)
60NSS-6FH6-TG3-S	6FH6	0.063 (1.59)	2.00 (50.8)	1.00 (25.4)	0.61 (15.6)	1.31 (33.3)	2.36 (59.9)	2.62 (66.6)	3.00 (76.2)	1.00 (25.4)	0.22 (5.6)	6.30 (160.1)	0.69 (17.5)	0.38 (9.7)	1.00 (25.4)
60NSS-6FH9-TG3-S	6FH9	0.078 (1.98)	2.62 (66.6)	1.31 (33.3)	0.95 (24.1)	1.31 (33.3)	2.68 (68.8)	2.62 (66.6)	3.00 (76.2)	1.00 (25.4)	0.28 (7.1)	6.65 (168.9)	0.69 (17.5)	0.38 (9.7)	1.50 (38.1)

60N Series (3-way/2 on pressure)															
Ordering Number	Connection	Orifice in. (mm)	Dimensions, in. (mm)												
			A	B	C	D	D1	E	F	G	G1	H	M	N	Thickness
60NSS-6FH4-TG4-S	6FH4	0.063 (1.59)	2.00 (50.8)	1.00 (25.4)	0.47 (11.9)	1.69 (42.9)	1.31 (33.3)	2.38 (60.5)	3.00 (76.2)	1.00 (25.4)	0.22 (5.6)	5.26 (133.6)	0.69 (17.5)	0.38 (9.7)	1.00 (25.4)
60NSS-6FH6-TG4-S	6FH6	0.063 (1.59)	2.00 (50.8)	1.00 (25.4)	0.61 (15.6)	1.69 (42.9)	1.31 (33.3)	2.75 (68.9)	3.00 (76.2)	1.00 (25.4)	0.22 (5.6)	5.34 (135.8)	0.69 (17.5)	0.38 (9.7)	1.00 (25.4)
60NSS-6FH9-TG4-S	6FH9	0.078 (1.98)	2.62 (66.6)	1.31 (33.3)	0.95 (24.1)	1.75 (44.5)	1.31 (33.3)	3.03 (77.0)	3.00 (76.2)	1.00 (25.4)	0.28 (7.1)	5.67 (143.9)	0.69 (17.5)	0.38 (9.7)	1.50 (38.1)

60N Series (3-way/1 on pressure)															
Ordering Number	Connection	Orifice in. (mm)	Dimensions, in. (mm)												
			A	B	C	D	D1	E	F	G	G1	H	M	N	Thickness
60NSS-6FH4-TG5-S	6FH4	0.063 (1.59)	2.00 (50.8)	1.00 (25.4)	0.47 (11.9)	1.31 (33.3)		2.38 (60.5)	3.00 (76.2)	1.00 (25.4)	0.22 (5.6)	5.02 (127.5)	0.69 (17.5)	0.38 (9.7)	1.00 (25.4)
60NSS-6FH6-TG5-S	6FH6	0.063 (1.59)	2.00 (50.8)	1.00 (25.4)	0.61 (15.6)	1.31 (33.3)		2.62 (66.6)	3.00 (76.2)	1.00 (25.4)	0.22 (5.6)	5.26 (133.5)	0.69 (17.5)	0.38 (9.7)	1.00 (25.4)
60NSS-6FH9-TG5-S	6FH9	0.078 (1.98)	2.62 (66.6)	1.31 (33.3)	0.95 (24.1)	1.31 (33.3)		2.81 (71.4)	3.00 (76.2)	1.00 (25.4)	0.28 (7.1)	5.45 (138.5)	0.69 (17.5)	0.38 (9.7)	1.50 (38.1)

60N Series (3-way/2 stem manifold)															
Ordering Number	Connection	Orifice in. (mm)	Dimensions, in. (mm)												
			A	B	C	D	D1	E	F	G	G1	H	M	N	Thickness
60NSS-6FH4-TG6-S	6FH4	0.063 (1.59)	2.00 (50.8)	1.00 (25.4)	0.47 (11.9)	1.72 (43.69)	1.31 (33.3)	3.44 (87.4)	3.00 (76.2)	1.00 (25.4)	0.22 (5.6)	6.08 (154.5)	0.69 (17.5)	0.38 (9.7)	1.00 (25.4)
60NSS-6FH6-TG6-S	6FH6	0.063 (1.59)	2.00 (50.8)	1.00 (25.4)	0.61 (15.6)	1.88 (47.8)	1.31 (33.3)	3.75 (95.3)	3.00 (76.2)	1.00 (25.4)	0.22 (5.6)	6.39 (162.3)	0.69 (17.5)	0.38 (9.7)	1.00 (25.4)
60NSS-6FH9-TG6-S	6FH9	0.078 (1.98)	2.62 (66.6)	1.31 (33.3)	0.95 (24.1)	2.06 (52.3)	1.31 (33.3)	4.12 (104.7)	3.00 (76.2)	1.00 (25.4)	0.28 (7.1)	6.76 (171.8)	0.69 (17.5)	0.38 (9.7)	1.50 (38.1)

- NOTES: 1. G is the drill dimension of packing gland mounting hole.
 2. G1 is the dimension of bracket mounting hole.
 3. Panel mounting drill size: 0.25" all valves.
 4. H is the dimension of stem in closed position.
 5. All dimensions for reference only and subject to change. For dimensions not shown above, please contact FITOK group or our authorized distributors.

Medium & High Pressure Fittings and Tubing	Quick Couplings	Medium & High Pressure Valves	Line Filters	Sour Service Products	Subsea Valves	Tools and Installation Instructions	Technical Information
--	-----------------	-------------------------------	--------------	-----------------------	---------------	-------------------------------------	-----------------------

Ordering Number Description

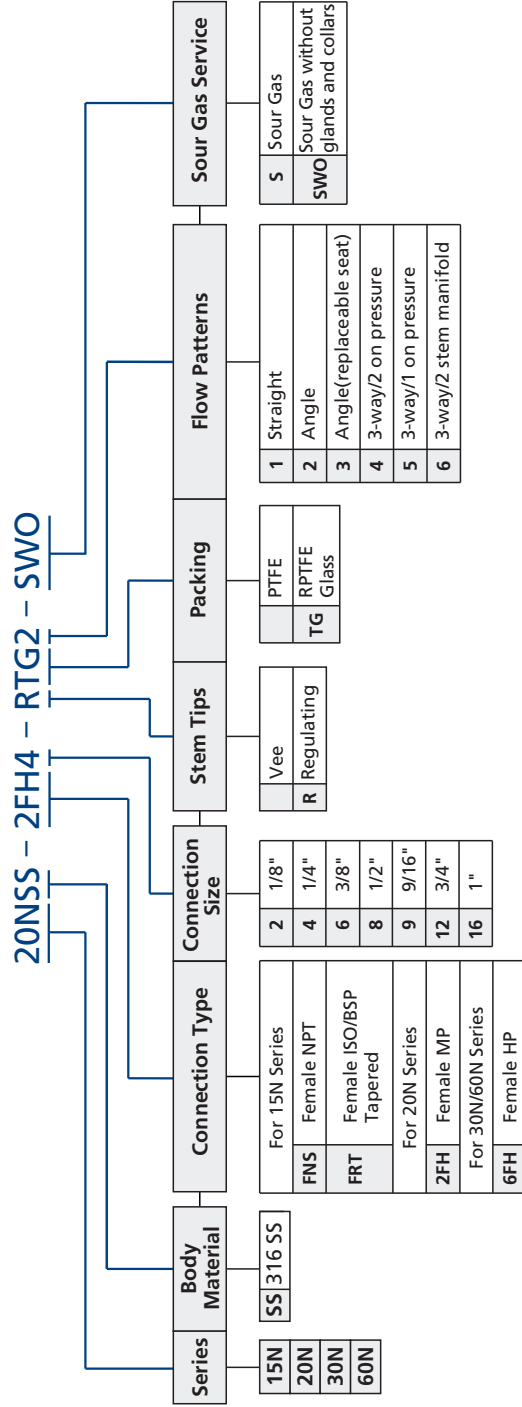

NOTE: "Ordering Number Description" is a reference to understand the combination rules of FITOK product part number. Not all combinations are available.

Bleed Valves

Pressures to 20,000 psig (1379 bar)

Features

- ⦿ One piece hex construction compact design allows easy installation
- ⦿ Working temperature range: -20°F to 400°F (-29°C to 204°C)
- ⦿ 1/8" Female NPT outlet connection
- ⦿ Easy to assemble and replace O-ring
- ⦿ Positive locking screw design prevents accidental removal of the stem
- ⦿ Tee handle for easy operation

Technical Data

Series	Inlet Connection	Orifice in. (mm)	Working Pressure psig (bar)
20BV	2MP6	0.094 (2.4)	10,000 (690)
	2MP9	0.094 (2.4)	10,000 (690)
	2CT6	0.094 (2.4)	10,000 (690)
	2CT9	0.094 (2.4)	10,000 (690)
30BV	6MP6	0.094 (2.4)	20,000 (1379)
	6MP9	0.094 (2.4)	20,000 (1379)
	6CT6	0.094 (2.4)	20,000 (1379)
	6CT9	0.094 (2.4)	20,000 (1379)

- NOTES: 1. Working pressure shown is in closed position.
 2. Working pressure is 10,000 psig (690 bar) in open position.
 3. A variety of end connections available on request. For connections not shown above, please contact FITOK Group or our authorized distributors.

Standard Materials of Construction

Item	Component	Material Grade/ASTM Specification
1	Handle Screw	Stainless steel
2	Handle	Stainless steel
3	Locking screw	Stainless steel
4	<i>Body</i>	<i>Annealed 316 SS</i>
5	<i>Stem</i>	<i>Alloys 725</i>
6	<i>O-Ring</i>	<i>FFKM</i>
	Lubricant	Molybdenum disulfide/Fluorinated-based

Wetted components listed in italics.

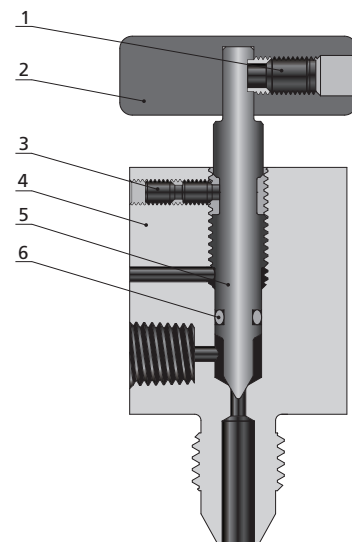

Ordering Information and Dimensions

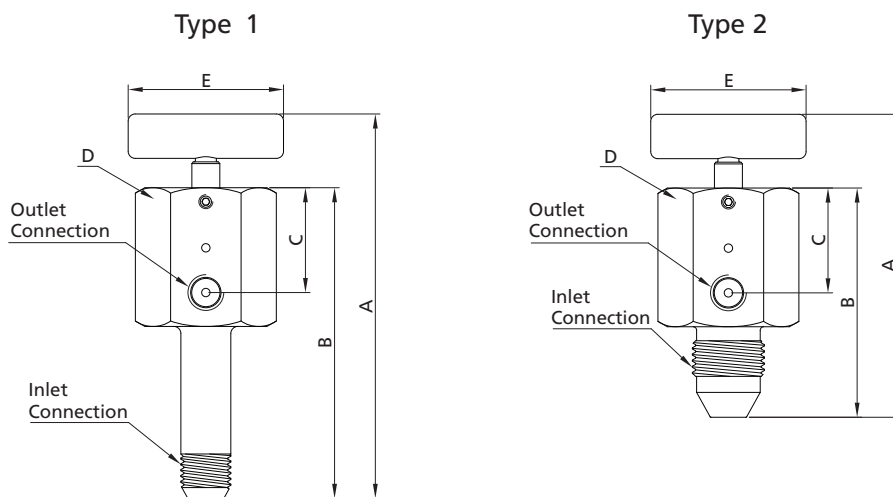

Type 1								
Ordering Number	Inlet Connection	Outlet Connection	Orifice in. (mm)	Dimensions, in. (mm)				
				A	B	C	D	E
20BVSS-2CT6-FNS2-S	2CT6	FNS2	0.094 (2.4)	3.65 (92.6)	2.81 (71.5)	1.18 (30.0)	1.37 (34.9)	1.75 (44.5)
20BVSS-2CT9-FNS2-S	2CT9	FNS2	0.094 (2.4)	3.93 (99.8)	3.10 (78.7)	1.18 (30.0)	1.37 (34.9)	1.75 (44.5)
30BVSS-6CT6-FNS2-S	6CT6	FNS2	0.094 (2.4)	3.93 (99.8)	3.10 (78.7)	1.18 (30.0)	1.37 (34.9)	1.75 (44.5)
30BVSS-6CT9-FNS2-S	6CT9	FNS2	0.094 (2.4)	4.38 (111.3)	3.55 (90.2)	1.18 (30.0)	1.37 (34.9)	1.75 (44.5)

Type 2								
Ordering Number	Inlet Connection	Outlet Connection	Orifice in. (mm)	Dimensions, in. (mm)				
				A	B	C	D	E
20BVSS-2MP6-FNS2-S	2MP6	FNS2	0.094 (2.4)	3.41 (86.7)	2.58 (65.6)	1.18 (30.0)	1.37 (34.9)	1.75 (44.5)
20BVSS-2MP9-FNS2-S	2MP9	FNS2	0.094 (2.4)	3.41 (86.7)	2.58 (65.6)	1.18 (30.0)	1.37 (34.9)	1.75 (44.5)
30BVSS-6MP6-FNS2-S	6MP6	FNS2	0.094 (2.4)	3.41 (86.7)	2.58 (65.6)	1.18 (30.0)	1.37 (34.9)	1.75 (44.5)
30BVSS-6MP9-FNS2-S	6MP9	FNS2	0.094 (2.4)	3.41 (86.7)	2.58 (65.6)	1.18 (30.0)	1.37 (34.9)	1.75 (44.5)

- NOTES: 1. D is the dimension of hex.
 2. A is the dimension of stem in closed position.
 3. All dimensions are for reference only and are subject to change. For dimensions not shown above, please contact FITOK Group or our authorized distributors.

Ordering Number Description

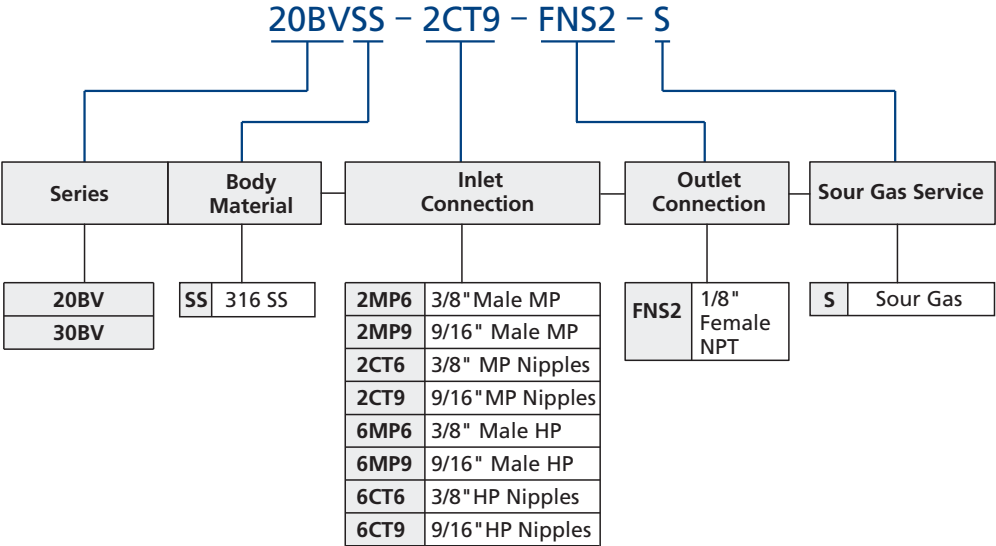

NOTE: "Ordering Number Description" is a reference to understand the combination rules of FITOK product part number. Not all combinations are available.

Medium & High Pressure Fittings and Tubing
Quick Couplings
Medium & High Pressure Valves
Line Filters
Sour Service Products
Subsea Valves
Tools and Installation Instructions
Technical Information

Gauge Valves

Pressures to 20,000 psig (1379 bar)

Features

- ⦿ One inlet, three outlet ports.
- ⦿ Metal-to-metal seating achieves ideal shutoff, longer stem/seat service lifetime for abrasive flow, excellent corrosion resistance and greater durability for repeated on/off cycles
- ⦿ Selected materials of packing gland and upper stem for reduced handle torque and extended thread cycle life
- ⦿ Packing located under stem threads
- ⦿ Reliable locking device for packing gland

Flow Data at 100°F (38°C)

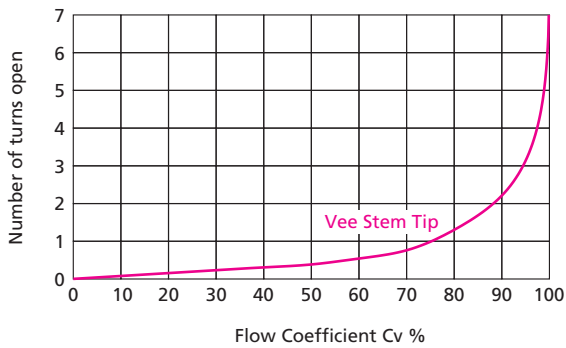

Pressure vs. Temperature Curve

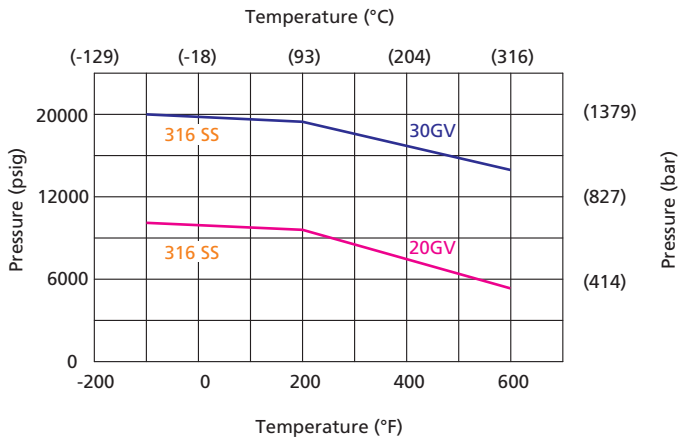

Medium & High Pressure Fittings and Tubing
 Quick Couplings
 Medium & High Pressure Valves
 Line Filters
 Sour Service Products
 Subsea Valves
 Tools and Installation Instructions
 Technical Information

Technical Data

Series	Connection	Orifice in. (mm)	Cv	Working Pressure psig (bar)
20GV	2FH6	0.125 (3.18)	0.23	10,000 (690)
	2FH9	0.125 (3.18)	0.23	10,000 (690)
30GV	6FH6	0.125 (3.18)	0.33	20,000 (1379)
	6FH9	0.125 (3.18)	0.33	20,000 (1379)

NOTES: 1. Packing Options

PTFE is the standard packing material, RPTFE glass also available

PTFE: -100°F~450°F (-73°C~232°C).

RPTFE glass: -100°F~600°F (-73°C~316°C).

2. A variety of end connections are available upon request. For connections not shown above, please contact FITOK Group or our authorized distributors.

Standard Materials of Construction

Item	Component	Material Grade/ASTM Specification
1	Handle	Stainless steel
2	Upper stem	316 SS/A479
3	Packing Gland	316 SS/A479
4	<i>Lower Stem</i>	<i>Alloy 725</i>
5	Packing Ring	316 SS/A479
6	<i>Packing</i>	<i>PTFE/RPTFE</i>
7	<i>Packing washer</i>	<i>316 SS/A479</i>
8	<i>Body</i>	<i>Annealed 316 SS</i>
	Lubricant	Molybdenum disulfide

Wetted components listed in italics.

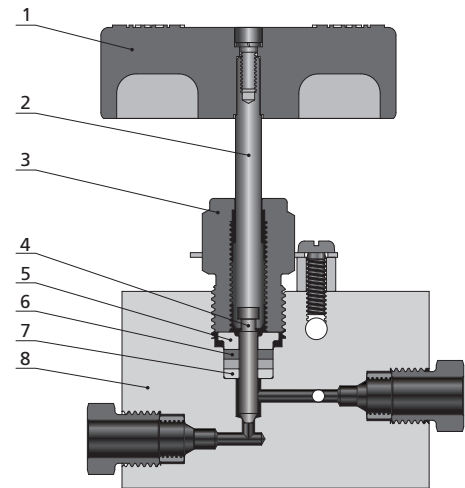

Medium & High Pressure Fittings and Tubing

Quick Couplings

Medium & High Pressure Valves

Line Filters

Sour Service Products

Subsea Valves

Tools and Installation Instructions

Technical Information

Ordering Information and Dimensions

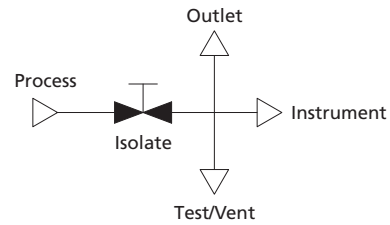
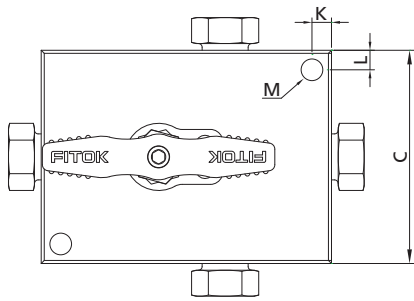
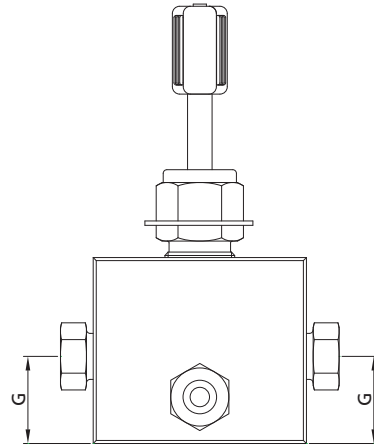
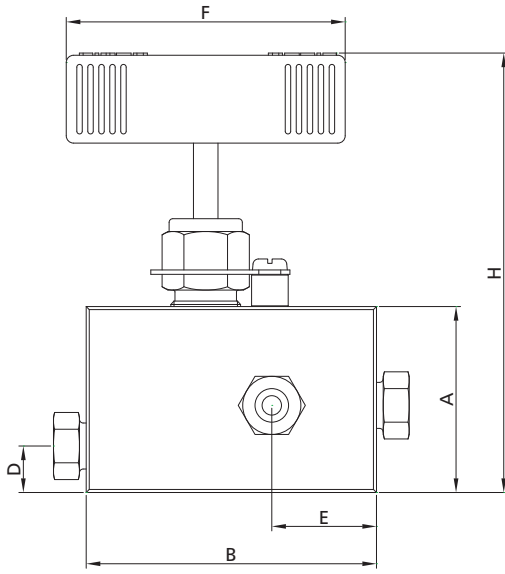

Ordering Number	Connection	Orifice in. (mm)	Dimensions, in. (mm)										
			A	B	C	D	E	F	G	H	K	L	M
20GVSS-2FH6-S	2FH6	0.125 (3.18)	2.00 (50.8)	3.12 (79.3)	2.00 (50.8)	0.50 (12.7)	1.13 (28.6)	3.00 (76.2)	0.94 (23.8)	4.68 (118.9)	0.38 (9.7)	0.25 (6.4)	0.28 (7.1)
20GVSS-2FH9-S	2FH9	0.125 (3.18)	2.00 (50.8)	3.88 (98.6)	2.75 (69.9)	0.66 (16.8)	1.38 (34.9)	3.00 (76.2)	0.94 (23.8)	4.68 (118.9)	0.38 (9.7)	0.38 (9.7)	0.28 (7.1)
30GVSS-6FH6-S	6FH6	0.125 (3.18)	2.00 (50.8)	3.12 (79.3)	2.00 (50.8)	0.50 (12.7)	1.13 (28.6)	3.00 (76.2)	0.94 (23.8)	4.68 (118.9)	0.38 (9.7)	0.38 (9.7)	0.28 (7.1)
30GVSS-6FH9-S	6FH9	0.125 (3.18)	2.00 (50.8)	3.88 (98.6)	2.75 (69.9)	0.66 (16.8)	1.38 (34.9)	3.00 (76.2)	0.94 (23.8)	4.68 (118.9)	0.38 (9.7)	0.38 (9.7)	0.28 (7.1)

- NOTES: 1. M is the panel mounting drill size.
 2. H is the dimension of stem in closed position.
 3. All dimensions are for reference only and are subject to change. For dimensions not shown above, please contact FITOK Group or our authorized distributors.

Ordering Number Description

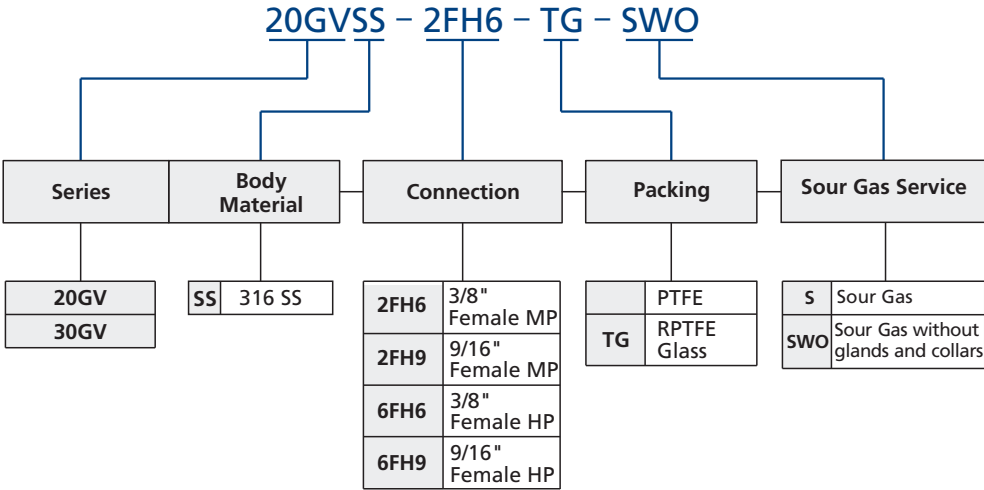

NOTE: "Ordering Number Description" is a reference to understand the combination rules of FITOK product part number. Not all combinations are available.

Medium & High Pressure Fittings and Tubing
Quick Couplings
Medium & High Pressure Valves
Line Filters
Sour Service Products
Subsea Valves
Tools and Installation Instructions
Technical Information

Check Valves

Pressures to 30,000 psig (2068 bar)

Features

(Pipe) O-ring Check Valves

- ⦿ Provides unidirectional flow and tight shut-off for liquids and gases with high reliability (Not for use as relief valve)
- ⦿ Resilient O-ring seat design for noise-free closing and zero leakage
- ⦿ Cracking pressure: 14 psig~26 psig (0.966 bar~1.794 bar)

(Pipe) Ball Check Valves

- ⦿ Prevents reverse flow where leak-tight shut-off is not mandatory (Not for use as relief valve)
- ⦿ An integral design of the ball and poppet to assure positive, in-line seating without "chatter".
 Poppet designed essentially for axial flow with minimum pressure drop

Standard Materials of Construction

15C Series Pipe O-ring Check Valves

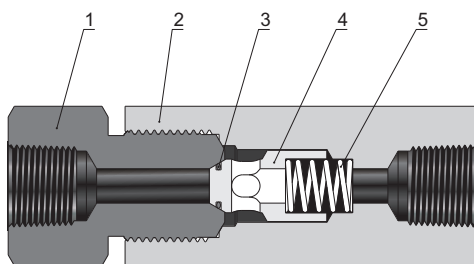

Item	Component	Material
1	Cover Gland	Annealed stainless steel
2	Valve Body	Annealed 316 SS
3	O-ring	FFKM
4	Poppet	Annealed 316 SS
5	Spring	High nickel alloy
	Lubricant	Molybdenum disulfide

15CO Series Pipe Ball Check Valves

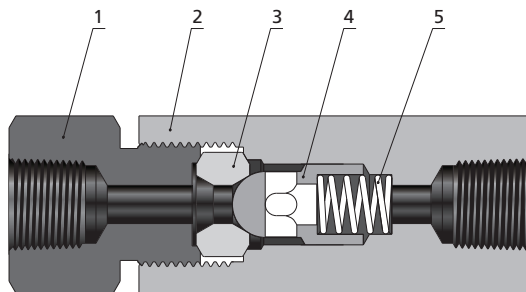

Item	Component	Material
1	Cover Gland	Annealed stainless steel
2	Valve Body	Annealed 316 SS
3	Cover	Alloy 725
4	Ball Poppet	Alloy 725
5	Spring	High nickel alloy
	Lubricant	Molybdenum disulfide

20C Series O-ring Check Valves

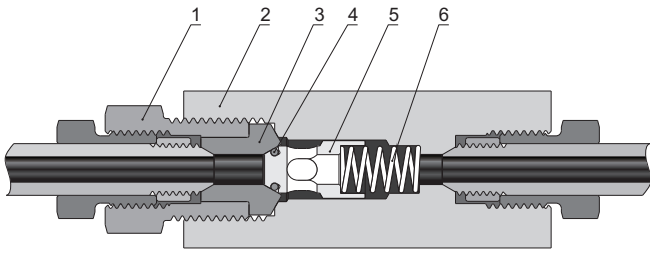

Item	Component	Material
1	Cover Gland	Annealed stainless steel
2	Valve Body	<i>Annealed 316 SS</i>
3	Cover	<i>Annealed 316 SS</i>
4	O-ring	<i>FFKM</i>
5	Poppet	<i>Annealed 316 SS</i>
6	Spring	<i>High nickel alloy</i>
	Lubricant	Molybdenum disulfide

20CO Series Ball Check Valves

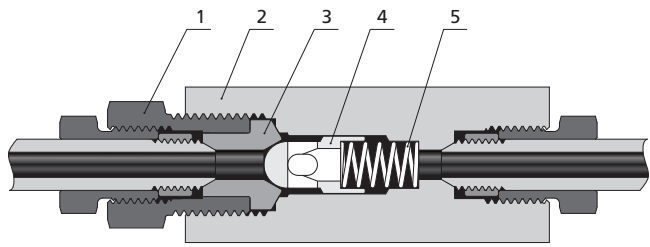

Item	Component	Material
1	Cover Gland	Annealed stainless steel
2	Valve Body	<i>Annealed 316 SS</i>
3	Cover	<i>Alloy 725</i>
4	Ball Poppet	<i>Alloy 725</i>
5	Spring	<i>High nickel alloy</i>
	Lubricant	Molybdenum disulfide

60C Series O-ring Check Valves

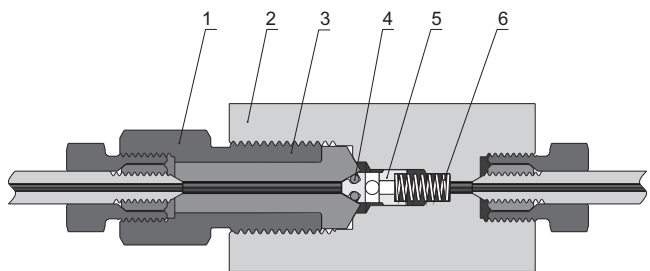

Item	Component	Material
1	Cover Gland	Annealed stainless steel
2	Valve Body	<i>Annealed 316 SS</i>
3	Cover	<i>Annealed 316 SS</i>
4	O-ring	<i>FFKM</i>
5	Poppet	<i>Annealed 316 SS</i>
6	Spring	<i>High nickel alloy</i>
	Lubricant	Molybdenum disulfide

60CO Series Ball Check Valves

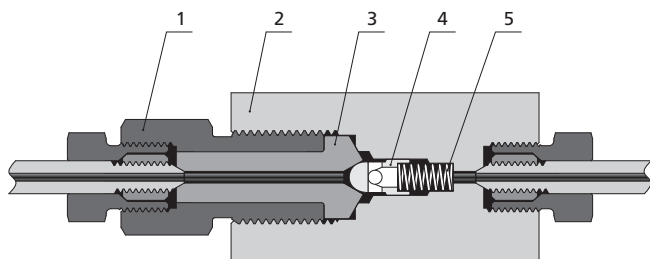

Item	Component	Material
1	Cover Gland	Annealed stainless steel
2	Valve Body	<i>Annealed 316 SS</i>
3	Cover	<i>Alloy 725</i>
4	Ball Poppet	<i>Alloy 725</i>
5	Spring	<i>High nickel alloy</i>
	Lubricant	Molybdenum disulfide

Wetted components listed in italics.

Ordering Information and Dimensions

15C Series Pipe O-ring Check Valves

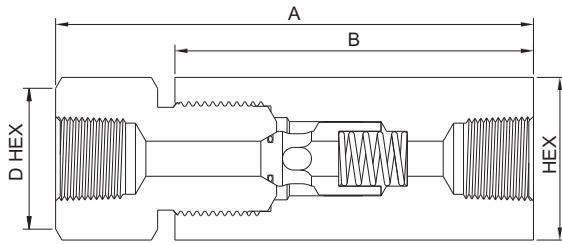

Ordering Number	Connection	Orifice in. (mm)	Cv	Dimensions, in. (mm)				Working Pressure psig (bar)	Working Temperature °F (°C)
				A	B	D - HEX	HEX		
15CSS-FNS4-S	FNS4	0.12 (3.05)	0.28	3.30 (83.8)	2.38 (60.3)	0.94 (23.8)	0.94 (23.8)	10,000 (690)	-20°F to 400°F (-29°C to 204°C)
15CSS-FNS6-S	FNS6	0.22 (5.59)	0.84	3.95 (100.33)	2.88 (73.2)	1.13 (28.6)	1.13 (28.6)		
15CSS-FNS8-S	FNS8	0.36 (9.12)	2.30	5.07 (128.8)	3.88 (98.6)	1.38 (34.9)	1.38 (34.9)		

15CO Series Pipe Ball Check Valves

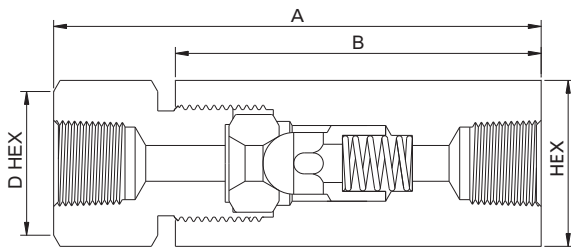

Ordering Number	Connection	Orifice in. (mm)	Cv	Dimensions, in. (mm)				Working Pressure psig (bar)	Working Temperature °F (°C)
				A	B	D - HEX	HEX		
15COSS-FNS4-S	FNS4	0.12 (3.05)	0.28	3.30 (83.8)	2.38 (60.3)	0.94 (23.8)	0.94 (23.8)	10,000 (690)	-20°F to 400°F (-29°C to 204°C)
15COSS-FNS6-S	FNS6	0.22 (5.59)	0.84	3.95 (100.33)	2.88 (73.2)	1.13 (28.6)	1.13 (28.6)		
15COSS-FNS8-S	FNS8	0.36 (9.12)	2.30	5.07 (128.8)	3.88 (98.6)	1.38 (34.9)	1.38 (34.9)		

Medium & High Pressure Fittings and Tubing
Quick Couplings
Medium & High Pressure Valves
Line Filters
Sour Service Products
Subsea Valves
Tools and Installation Instructions
Technical Information

20C Series O-ring Check Valves

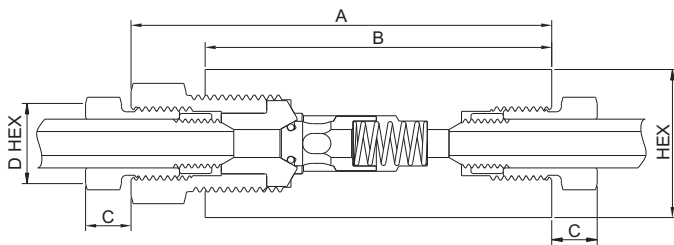

Ordering Number	Connection	Orifice in. (mm)	Cv	Dimensions, in. (mm)					Working Pressure psig (bar)	Working Temperature °F (°C)
				A	B	C	D - HEX	HEX		
20CSS-2FH4-S	2FH4	0.125 (3.18)	0.28	2.94 (74.7)	2.50 (63.5)	0.38 (9.65)	0.50 (12.7)	0.81 (20.6)	10,000 (690)	-20°F to 550°F (-29°C to 288°C)
20CSS-2FH6-S	2FH6	0.218 (5.54)	0.84	3.12 (79.3)	2.62 (66.6)	0.44 (11.2)	0.62 (15.8)	1.00 (25.4)		
20CSS-2FH9-S	2FH9	0.359 (9.12)	2.30	4.18 (106.2)	3.50 (88.9)	0.55 (14.0)	0.94 (23.9)	1.38 (35.1)		
20CSS-2FH12-S	2FH12	0.516 (13.11)	4.70	5.50 (139.7)	4.75 (120.7)	0.60 (15.2)	1.19 (30.2)	1.75 (44.5)		
20CSS-2FH16-S	2FH16	0.688 (17.48)	7.40	6.91 (175.6)	5.75 (146.1)	0.74 (18.8)	1.38 (35.1)	2.12 (53.9)		

20CO Series Ball Check Valves

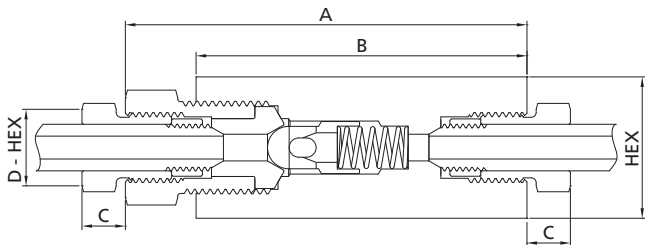

Ordering Number	Connection	Orifice in. (mm)	Cv	Dimensions, in. (mm)					Working Pressure psig (bar)	Working Temperature °F (°C)
				A	B	C	D - HEX	HEX		
20COSS-2FH4-S	2FH4	0.125 (3.18)	0.28	2.94 (74.7)	2.50 (63.5)	0.38 (9.65)	0.50 (12.7)	0.81 (20.6)	10,000 (690)	-110°F to 1200°F (-79°C to 649°C)
20COSS-2FH6-S	2FH6	0.218 (5.54)	0.84	3.12 (79.3)	2.62 (66.6)	0.44 (11.2)	0.62 (15.8)	1.00 (25.4)		
20COSS-2FH9-S	2FH9	0.359 (9.12)	2.30	4.18 (106.2)	3.50 (88.9)	0.55 (14.0)	0.94 (23.9)	1.38 (35.1)		
20COSS-2FH12-S	2FH12	0.516 (13.11)	4.70	5.50 (139.7)	4.75 (120.7)	0.60 (15.2)	1.19 (30.2)	1.75 (44.5)		
20COSS-2FH16-S	2FH16	0.688 (17.48)	7.40	6.91 (175.6)	5.75 (146.1)	0.74 (18.8)	1.38 (35.1)	2.12 (53.9)		

Medium & High Pressure Fittings and Tubing

Quick Couplings

Medium & High Pressure Valves

Line Filters

Sour Service Products

Subsea Valves

Tools and Installation Instructions

Technical Information

60C Series O-ring Check Valves

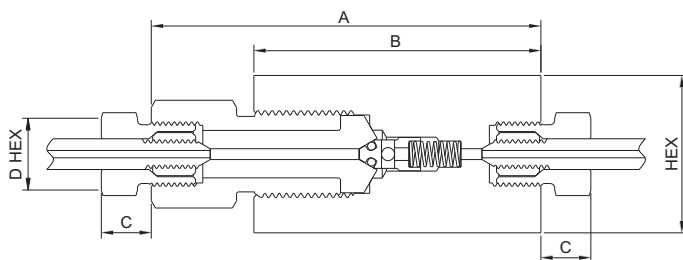

Ordering Number	Connection	Orifice in. (mm)	Cv	Dimensions, in. (mm)					Working Pressure psig (bar)	Working Temperature °F (°C)
				A	B	C	D - HEX	HEX		
60CSS-6FH4-S	6FH4	0.094 (2.39)	0.15	3.38 (85.9)	2.50 (63.5)	0.47 (11.9)	0.63 (16.0)	1.18 (30.0)	30,000 (2068)	-20°F to 550°F (-29°C to 288°C)
60CSS-6FH6-S	6FH6	0.125 (3.18)	0.28	3.86 (98.1)	2.80 (71.0)	0.61 (15.5)	0.81 (20.6)	1.18 (30.0)		
60CSS-6FH9-S	6FH9	0.187 (4.75)	0.63	4.62 (117.4)	3.38 (85.85)	0.95 (24.1)	1.12 (28.5)	1.50 (38.1)		

60CO Series Ball Check Valves

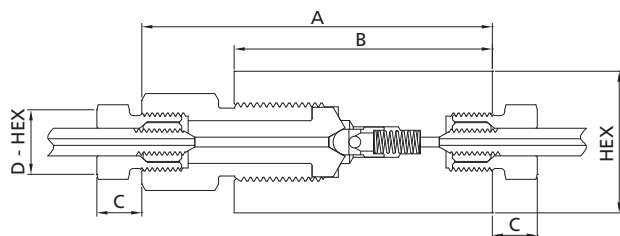

Ordering Number	Connection	Orifice in. (mm)	Cv	Dimensions, in. (mm)					Working Pressure psig (bar)	Working Temperature °F (°C)
				A	B	C	D - HEX	HEX		
60COSS-6FH4-S	6FH4	0.094 (2.39)	0.15	3.38 (85.9)	2.50 (63.5)	0.47 (11.9)	0.63 (16.0)	1.18 (30.0)	30,000 (2068)	-110°F to 1200°F (-79°C to 649°C)
60COSS-6FH6-S	6FH6	0.125 (3.18)	0.28	3.86 (98.1)	2.80 (71.0)	0.61 (15.5)	0.81 (20.6)	1.18 (30.0)		
60COSS-6FH9-S	6FH9	0.187 (4.75)	0.63	4.62 (117.4)	3.38 (85.85)	0.95 (24.1)	1.12 (28.5)	1.50 (38.1)		

NOTE: All dimensions are for reference only and are subject to change. For dimensions not shown above, please contact FITOK Group or our authorized distributors.

Medium & High Pressure Fittings and Tubing
Quick Couplings
Medium & High Pressure Valves
Line Filters
Sour Service Products
Subsea Valves
Tools and Installation Instructions
Technical Information

Ordering Number Description

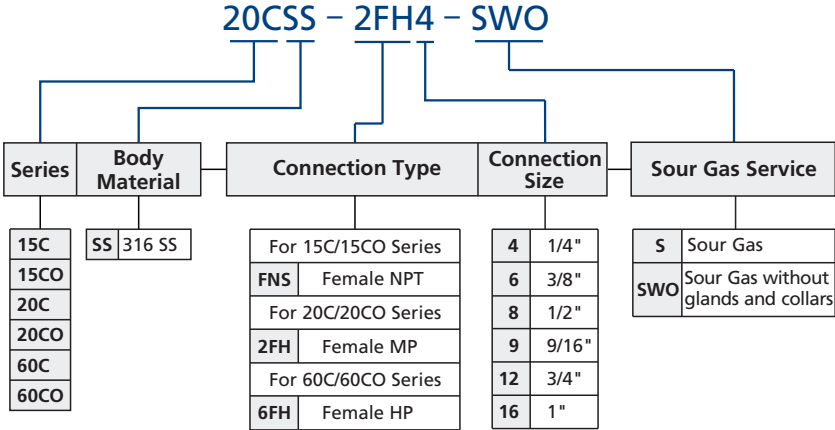

NOTE: "Ordering Number Description" is a reference to understand the combination rules of FITOK product part number. Not all combinations are available.

Medium & High Pressure Fittings and Tubing
Quick Couplings
Medium & High Pressure Valves
Line Filters
Sour Service Products
Subsea Valves
Tools and Installation Instructions
Technical Information