

550°C RTD Probes

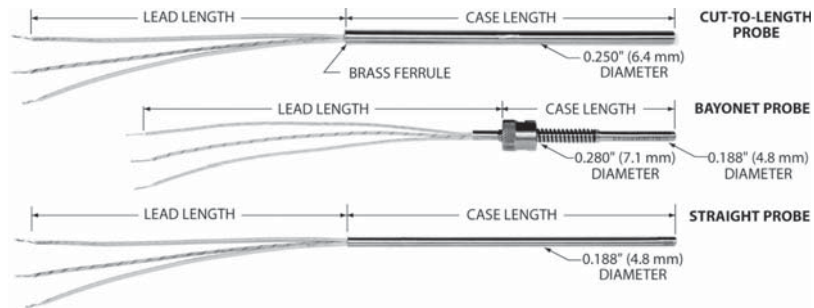

Overview

Install these probes in steam lines, exhaust gases, or wherever you need precise readings of elevated temperatures. RTD probes feature high temperature ceramic elements, assembled into stainless steel cases in a configuration that provides long-term reliable service.

Models S80 and S81 can be shortened by the user. You can stock standard lengths and cut them to the size required with an ordinary tubing cutter.

Bayonet-style probes have a lockcap and spring for spring-loaded installation. See page 3-9 for more information on bayonet fittings.

- 0.250" diameter cut-to-length RTDs
- 0.188" diameter straight and bayonet RTDs

Specifications

Temperature range:

-100 to 550°C (-148 to 1022°F).

Leadwires: 500°C (932°F) max.

Case: 316 stainless steel.

Minimum case length:

0.250" diameter: S80, S81: 4.0" (101.6 mm).

0.188" diameter: S71, S72: 2.0" (50.8 mm)
S73, S74: 3.0" (76.2 mm).

Maximum case length: 48" (1220 mm), longer on special order.

Pressure rating: 1500 psi (103 bar).

Vibration: Withstands 10 to 2000 Hz at 20 G's minimum per MIL-STD-202, Method 204, Test Condition D.

Shock: Withstands 100 G's minimum sine wave shock of 8 milliseconds duration.

Leads: 2 or 3 leadwires, AWG 22, stranded copper with mica/glass insulation. For 2-lead RTDs add 0.04 Ω per foot of combined case and lead length to element tolerance.

Time constant: 10 seconds typical in moving water.

Insulation resistance: 10 megohms min. at 100 VDC, leads to case.

Model numbers:

Straight probe: Ø 0.188" (4.8 mm)

Element	Model
Platinum (0.00391 TCR) 100 Ω ±0.1% at 0°C	▼ S71PB
Platinum (0.00385 TCR)* 100 Ω ±0.1% at 0°C	▼ S72PD

Bayonet probe: Ø 0.188" (4.8 mm)

Element	Model
Platinum (0.00391 TCR) 100 Ω ±0.1% at 0°C	▼ S73PB
Platinum (0.00385 TCR)* 100 Ω ±0.1% at 0°C	▼ S74PD

Cut-to-length: Ø 0.250" (6.4 mm)

Element	Model
Platinum (0.00391 TCR) 100 Ω ±0.1% at 0°C	▼ S80PB
Platinum (0.00385 TCR)* 100 Ω ±0.1% at 0°C	▼ S81PD

*Meets EN60751, Class B

Specification and order options

S74PD	Model number from table
240	Case length: Specify in 0.1" increments (Ex: 240 = 24.0 inches) ▼: 20, 30, 120, 240
Z	Number of leads: Y = 2 leads ▼ Z = 3 leads
36	Lead length in inches ▼: 36, 120
S74PD240Z36 = Sample part number	



STOCKED PARTS AVAILABLE

▼ = STANDARD OPTIONS
Specifications subject to change

550°C Thermocouple Probes

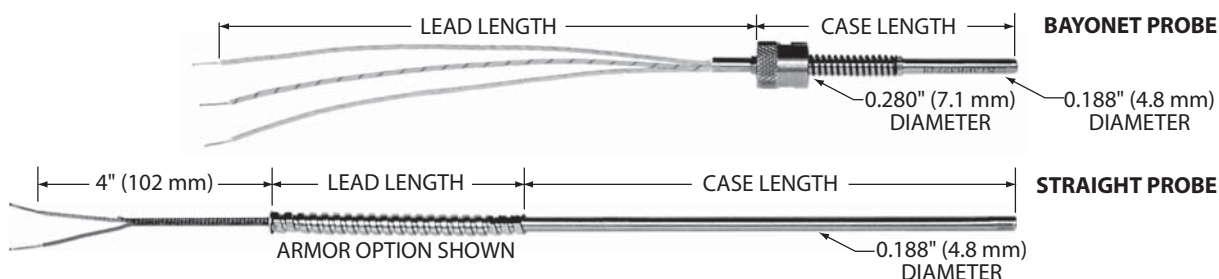

Overview

Install these probes in steam lines, exhaust gases, or wherever you need precise readings of elevated temperatures.

Bayonet-style probes have a lockcap and spring for spring-loaded installation. See page 3-9 for more information on bayonet fittings.

Specifications

Temperature range:

-100 to 550°C (-148 to 1022°F).

Leadwires: 500°C (932°F) max.

Case: 316 stainless steel.

Minimum case length: 2.5" (63.5 mm)

Maximum case length: 48" (1220 mm), longer on special order.

Pressure rating: 1500 psi (103 bar).

Vibration: Withstands 10 to 2000 Hz at 20 G's minimum per MIL-STD-202, Method 204, Test Condition D.

Shock: Withstands 100 G's minimum sine wave shock of 8 milliseconds duration.

Leads: Solid thermocouple wire, AWG 20. Specify glass braid insulation, stainless steel overbraid, or stainless steel armor.

Time constant: 7 seconds typical in moving water.

Insulation resistance: 10 megohms minimum at 100 VDC, leads to case, ungrounded junctions only.

Specification and order options

TC173	Model number: ▼TC173: Straight probe ▼TC171: Bayonet mount
E	Junction type: ▼E = Chromel-Constantan J = Iron-Constantan ▼K = Chromel-Alumel T = Copper-Constantan
U	Junction grounding: ▼G = Grounded ▼U = Ungrounded
60	Case length: Specify in 0.1" increments (Ex: 45 = 4.5 inches) ▼: 30, 60, 120, 180
G	Covering over leadwires: ▼G = Glass braid only ▼S = Stainless steel overbraid A = Stainless steel armor
120	Lead length in inches ▼: 120
TC173EU60G120 = Sample part number	

▼ = STANDARD OPTIONS

Specifications subject to change

600°C RTDs

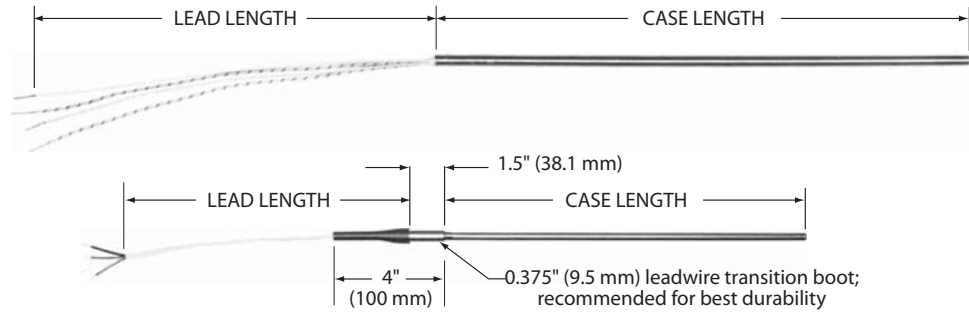

Overview

These RTDs cover the full temperature scale of the international standard EN60751. Precision sensing elements are capable of measurements from -200 to 600°C (-328 to 1112°F) with typical ice point drift less than $\pm 0.05^\circ\text{C}$.

- Platinum elements to EN60751, Class A or B
- English and metric diameters

Specifications

Element: Platinum, 100 Ω at 0°C, TCR = 0.00385 $\Omega/\Omega/^\circ\text{C}$.

Temperature range: -200 to 600°C (-328 to 1112°F). Reduced temperature rating for leads and last 2" (50 mm) of case — see leadwire chart.

Case: 316 stainless steel.

Minimum case length: 2.0" (50.8 mm).

Maximum case length: 48.0" (1220 mm), longer on special order.

Probe diameter	Model
0.188" (4.8 mm)	▼S914
0.236" (6.0 mm)	▼S912
0.250" (6.4 mm)	▼S913

Tolerance: EN60751 Class A or B.

Class A: $\pm 0.06\%$

Class B: $\pm 0.12\%$

Repeatability: Meet IEC requirements. Typical shift less than 0.05°C (0.02 Ω) at 0°C after ten cycles over range.

Stability: Meet IEC stability specifications after 250 hours exposure to extremes of temperature range. Typical drift is less than 0.05°C (0.02 Ω) at 0°C.

Vibration: Will withstand 10 to 5000 Hz at 2 G's minimum per EN60751.

Shock: Will withstand 250 mm drop onto 8 mm thick steel plate (approximately 1400 G's for 0.08 ms).

Time constant: 10 seconds typical in moving water.

Pressure rating: 1000 psi (69 bar) at 25°C.

Insulation resistance: 10 megohms minimum at 100 VDC, leads to case.

Leadwire options:

Code	Description	Max. temp.*
▼G	Mica/glass insulated stranded copper, AWG 22.	600°C 1112°F
T	PTFE insulated stranded copper, AWG 22.	260°C 500°F
C	AWG 24, PTFE insulated, stranded copper wires with silver-plated copper braid and PTFE over all (4 leads only).	260°C 500°F

* Temperature rating for leads and last 2" of case.

Specification and order options

S914	Model number from table
PD	100 Ω Platinum, 0.00385 TCR
06	Tolerance at 0°C: ▼06 = $\pm 0.06\%$, EN60751 Class A 12 = $\pm 0.12\%$, EN60751 Class B
G	Leadwire code from table
40	Case length: Specify in 0.1" increments (Ex: 40 = 4.0 inches) ▼: 40, 60, 90, 120, 180
Z	Number of leads: ▼Z = 3 leads X = 4 leads
120	Lead length in inches ▼: 120
BS	Probe termination: ▼BS = Boot and spring B = Boot only ▼N = No boot or spring
S914PD06G40Z120BS = Sample part number	

▼ = STANDARD OPTIONS

Specifications subject to change