

Flanged Thermowells

Overview

Flanged thermowells are available in three standard flange sizes: 1.0", 1.5", and 2.0" per ANSI B16.5. Specify U dimension and pressure rating.

Immerse the thermowell at least 2.5" (65 mm) for accurate readings. The well should extend beyond the center of the fluid stream without touching the opposite wall. Installation in an elbow or tee may be necessary for sufficient immersion in small pipes.

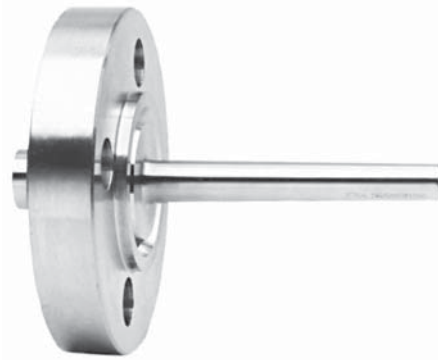

TW1219 Flanged Straight Thermowell

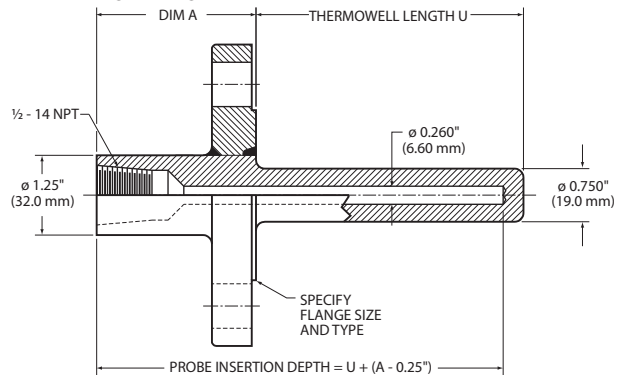

TW1220 Flanged Tapered Thermowell

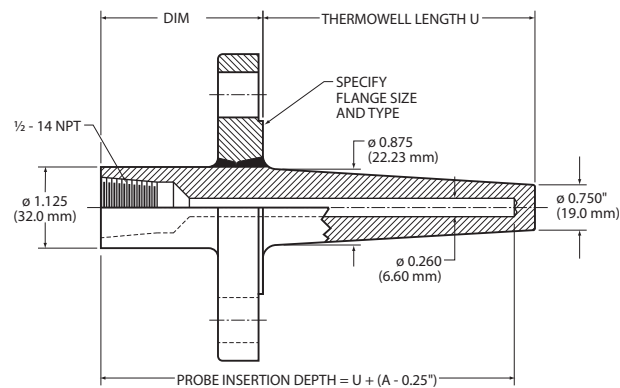

Specifications - Models TW1219 / TW1220

Body material: 316 stainless steel.

Temperature limit: 607°C (1125°F).

Pressure rating: Specify flange pressure rating.
(1 bar = 14.5 psi).

Pressure rating	Dimension A
150, 300, 400, 600 psi	2.25" (64mm)
900, 1500, 2500 psi	3.25" (83mm)

Thread: 1/2-14 NPT internal thread.

Probe diameter: 0.250" (6.4 mm).

Standard U dimensions: 2.5, 4.5, 6.0, 7.5, 8.0, 10.5, 13.5, 16.5, and 22.5". Other dimensions available.

Specification and order options:

TW1219	Model number: TW1219 = Straight TW1220 = Tapered
U	
105	Thermowell length U: Specify in 0.1" increments (Ex: 105 = 10.5 inches)
S	
10	Flange size: 10 = 1.0" 15 = 1.5" 20 = 2.0"
F	
300	Pressure rating in pounds per square inch
RF	Flange type: RF = Raised face RTJ = Ring type joint
TW1219U105S10F300RF = Sample part number	

▼ = STANDARD OPTIONS

Specifications subject to change