

TT205 Thermocouple Transmitters



TT205
Thermocouple Transmitter

Overview

Model TT205 interfaces with thermocouples for use in process control and other industrial applications.

Model TT205 offers superior performance in an economical and small package.

- Thermocouple input
- Fits DIN "B" style connection heads

Specifications

Output: 4 to 20 mA over specified range.

Accuracy: $\pm 0.2\%$ of span.

Linearity: Voltage linear.

The output signal is voltage linear (not temperature linear) and is intended for use with instruments which compensate for the nonlinear signal output of the thermocouples sensor.

Adjustments: Zero and span, $\pm 5\%$ of span, non-interacting. Factory set.

Warmup drift: $\pm 0.2\%$ of span max., with $V_{supply} = 24$ VDC and $R_{loop} = 250 \Omega$. Stable within 15 minutes.

Supply voltage: 8.5 to 35 VDC
Voltage effect $\pm 0.001\%$ of span per volt.
Reverse polarity protected.

Maximum load resistance: The maximum allowable resistance of the signal carrying loop is:

$$R_{loop\ max} = \frac{V_{supply} - 10}{0.020\ \text{amps}}$$

Example: With supply voltage 24 VDC, maximum loop resistance is 700 Ω .

Minimum output current: 1.5 mA.

Maximum output current: 28 mA.

Burnout: Downscale burnout standard; upscale optional.

Connections: Terminal block for wires AWG 22 to AWG 14.

Physical: Polycarbonate case, epoxy potted for moisture resistance.

Weight: 1.8 oz. (52 g).

▼ = STANDARD OPTIONS
Specifications subject to change

TT205

Ambient temperature:

Operating: -10 to 60°C (14 to 140°F).

Storage: -55 to 100°C (-67 to 212°F).

Ambient temperature effects: $\pm 0.036\%$ of span per °C.

Cold junction compensation drift: $\pm 0.05^\circ\text{C}$ per °C.

Minimum span: 150°C (270°F).

Specification and order options

| | |
|---------------------------------|---|
| TT205 | Model Number: TT190: Round TT205: Rectangular |
| J | TC junction type: E = Chromel-Constantan J = Iron-Constantan K = Chromel-Alumel T = Copper-Constantan |
| U | U = Ungrounded junction (required) |
| 1 | Output: 4 to 20 mA DC |
| AN | Temperature range code starting on page 4-20 [Ex: AN = -17.8 to 148.9°C (0 to 300°F)] |
| TT205JU1AN = Sample part number | |

TT205 Dimensions in inches (mm)

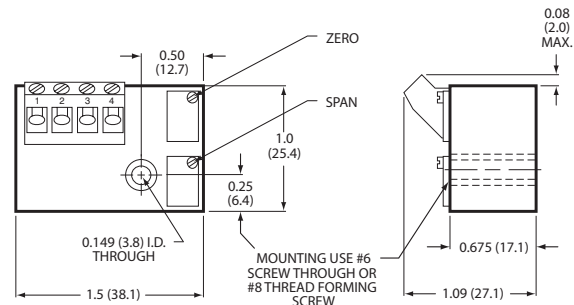

Wiring Diagram

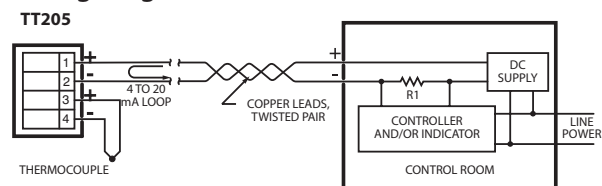

▼ = STANDARD OPTIONS
Specifications subject to change