

Hazardous Area Sensor Assemblies

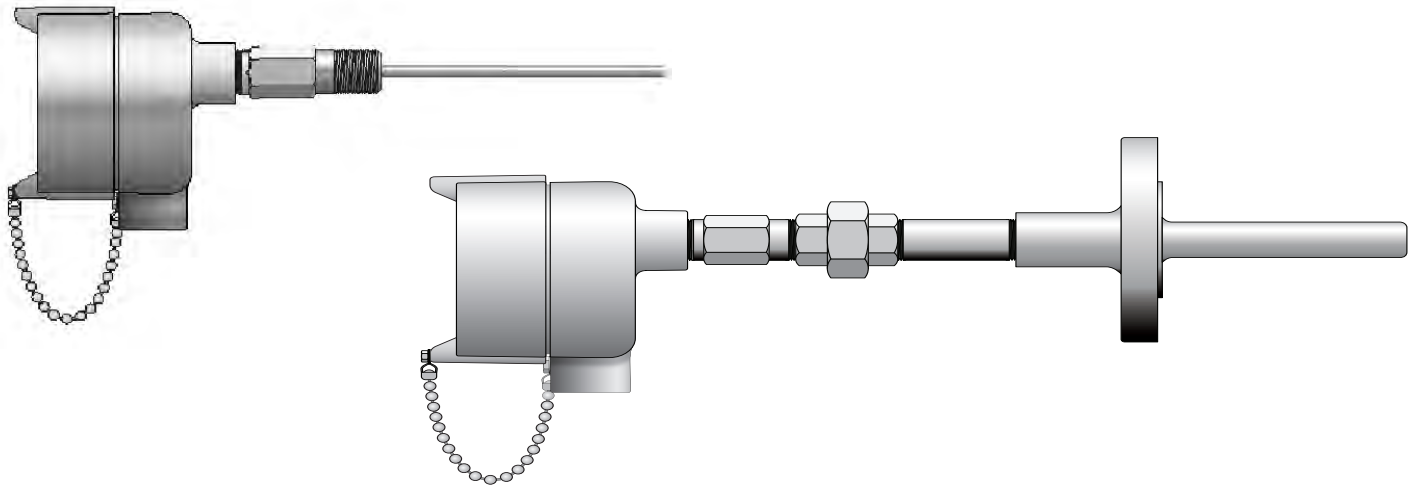

Overview

Whether you need to monitor bearing temperature, process temperature, or virtually any temperature in a hazardous area, Minco's AS9 series temperature sensor assembly can be configured to fit your application, and is certified to satisfy your requirements. Minco's AS9 series temperature sensors offers a single product with global certifications simplifying inventory management and reducing the complexities associated with complying with multiple regional standards.

- **Approval agencies:** IECEx, ATEX, CSA Canada (Canada and United States)
- **Area classifications:** Zone 0, Zone 1, Zone 2, Class I Division 1, Class I Division 2
- **Protection methods:** flameproof (Ex d), increased safety (Ex e), intrinsic safety (Ex i), explosionproof (XP), dustignitionproof (DIP), dust ignition protection by enclosure (Ex tb)
- **Probe options:** tip-sensitive, all stainless steel, mineral insulated
- **Output options:** resistance (RTD), voltage (thermocouple), current (4-20 mA), digital (HART®)
- **Fitting options:** spring-loaded, welded, union/nipple, ½-14 NPT, G ½ (ISO 228-1)
- **Connection head options:** copper-free aluminum (IP66/NEMA 4), powder coated aluminum (IP66/NEMA 4X), stainless steel (IP66/NEMA 4X), various conduit threads
- **Thermowell options:** threaded, flanged, tapered, reduced tip

Certifications

Minco's AS9 sensors are certified by multiple agencies. Consult the following list to learn more:



IECEx (IEC 60079):

Ex ia IIC T6...T2 Ga IP66
Ex db IIC T6...T2 Gb IP66
Ex tb IIIC T85...T160°C Db



ATEX (EN 60079):

II 1 G Ex ia IIC T6...T2 Ga IP66
2 G Ex db IIC T6...T2 Gb IP66
2 D Ex tb IIIC T85...T160°C Db



CSA Canada (CSA C22.2):

Class I, Zone 0, AEx ia IIC T6...T2
Class I, Zone 1, Ex db IIC T6...T2
Class II, Zone 21, Ex tb IIIC T85...T160°C
IS/XP Class I, Division 1, Groups B, C, D T6...T2
Class II, Division 1, Groups E, F, G T85...T160°C
Class III, Division 1

CSA USA (NEC 500 & 505):

Class I, Zone 0, AEx ia IIC T6...T2
Class I, Zone 1, AEx db IIC T6...T2
Class II, Zone 21, AEx tb IIIC T85...T160°C
IS/XP Class I, Division 1, Groups B, C, D T6...T2
Class II, Division 1, Groups E, F, G T85...T160°C
Class III, Division 1

Hazardous Area Sensor Assemblies

Select Probes and Fittings

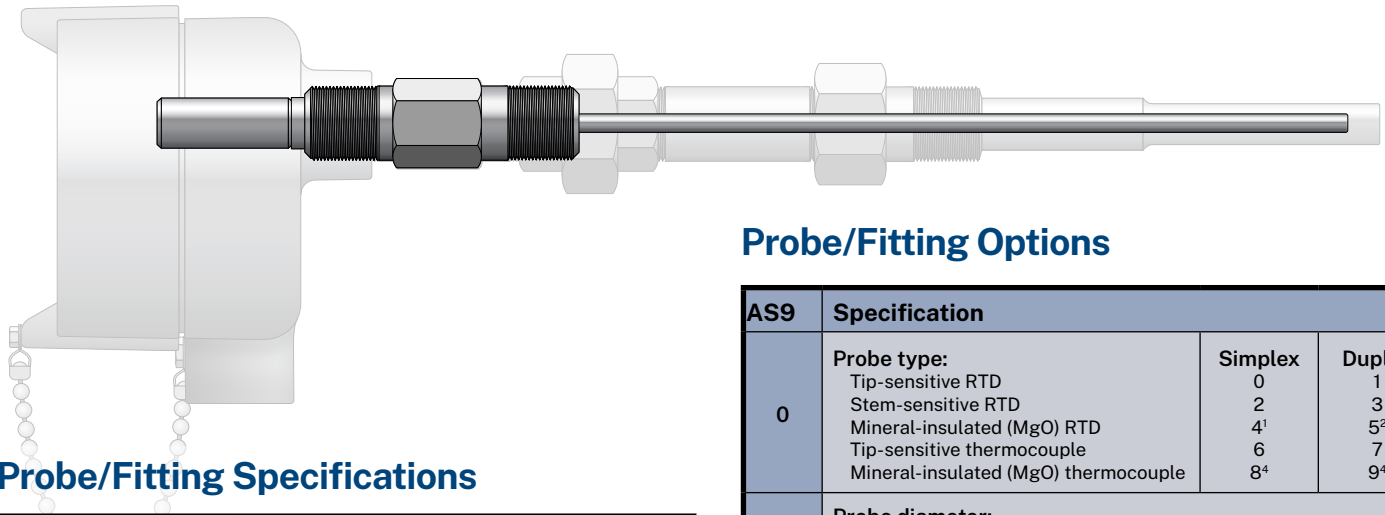

Probe/Fitting Specifications

Probe Type	Temperature Range Probe/Process
0, 1, 2, 3, 6, 7	-50 to 260°C (-58 to 500°F)
4, 5, 8, 9	-50 to 600°C (-58 to 1112°F)

Fitting Type	Pressure Rating
0, 3, 5, 8	50 psi (3.4 bar)
1, 6	715 psi (49.3 bar)
2, 7	None

Probe Type	Material (probe)
0, 1, 6, 7	Stainless steel with copper alloy tip for faster time response
2, 3, 4, 5, 8, 9	Stainless steel

**Not seeing your ideal configuration?
Contact us for a custom solution!**

Probe/Fitting Options

AS9	Specification		
0	Probe type:	Simplex	Duplex
	Tip-sensitive RTD	0	1
	Stem-sensitive RTD	2	3
	Mineral-insulated (MgO) RTD	4 ¹	5 ²
	Tip-sensitive thermocouple	6	7
Mineral-insulated (MgO) thermocouple	8 ⁴	9 ⁴	
0	Probe diameter:		
	0 = 6.4 mm (.250")		
	1 = 6.0 mm (.236")		
	2 = 5.5 mm (.215")		
	3 = 5.5 mm (.215"); thick wall for bending by hand		
4 = 4.8 mm (.188")			
0	Process thread \ fitting type:		
	0 = 1/2-14 NPT \ release knob spring-loaded		
	1 ²³ = 1/2-14 NPT \ welded		
	2 ¹ = 1/2-14 NPT \ fixed spring-loaded		
	3 = 1/2-14 NPT \ set screw spring-loaded		
	5 = G 1/2 \ release knob spring-loaded		
	6 ²³ = G 1/2 \ welded		
	7 ¹ = G 1/2 \ fixed spring-loaded		
8 = G 1/2 \ set screw spring-loaded			
AS9000PD100W3A0X0X1N1 = Sample part number			

1-Only available for Probe diameter options 0, 1

2-Only available for Probe diameter option 0

3-Only available for Probe type options 2, 3, 4, 5, 8, 9

4- Not available for Probe diameter option 2

Insulation resistance:

- 1000 megohms min at 100 VDC, leads to case.
- 100 megohms min at 100 VDC, leads to case (ungrounded junction thermocouples).
- 10 megohms min at 100 VDC, leads to case (mineral insulated RTDs and ungrounded mineral insulated thermocouples)

Dielectric strength:

- 600 Vrms at 60 Hz for 2 seconds with 5 mA maximum leakage current (probe leads to connection head).

Hazardous Area Sensor Assemblies

Select Sensing Element, Insertion Depth, and Lead Configuration

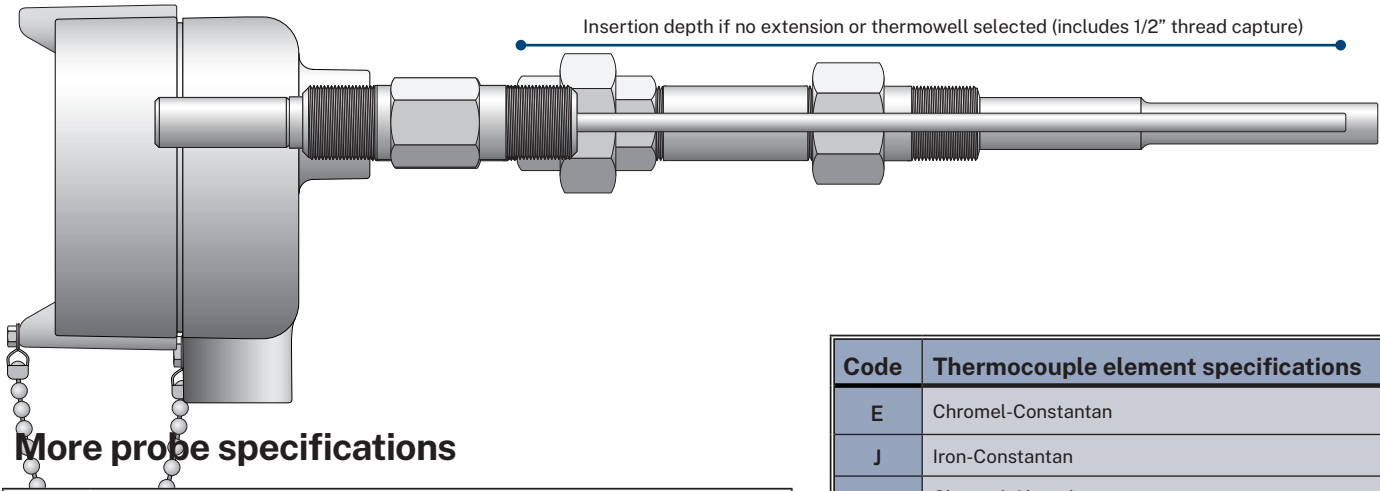

More probe specifications

Code	RTD element specifications
PA	Platinum (0.00392 Ω/Ω/°C); 100 Ω ±0.5% at 0°C Accuracy: ±1.3°C at 0°C
PD	Platinum (0.00385 Ω/Ω/°C); 100 Ω ±0.12% at 0°C Accuracy: ±0.3°C at 0°C (EN60751 Class B)
PM	Platinum (0.00385 Ω/Ω/°C); 100 Ω ±0.06% at 0°C Accuracy: ±0.15°C at 0°C (EN60751 Class A)
PF ⁷	Platinum (0.00385 Ω/Ω/°C); 1000 Ω ±0.12% at 0°C Accuracy: ±0.3°C at 0°C (EN60751 Class B)
PW ⁷	Platinum (0.00375 Ω/Ω/°C); 1000 Ω ±0.12% at 0°C Accuracy: ±0.3°C at 0°C
CA ⁵⁷	Copper (0.00427 Ω/Ω/°C); 10 Ω ±0.2% at 25°C Accuracy: ±0.5°C at 25°C
CC ⁶⁷	Copper (0.00427 Ω/Ω/°C); 10 Ω ±0.5% at 25°C Accuracy: ±1.3°C at 25°C
NA ⁷	Nickel (0.00672 Ω/Ω/°C); 120 Ω ±0.5% at 0°C Accuracy: ±0.8°C at 0°C
NB ⁶	Nickel (0.00618 Ω/Ω/°C); 100 Ω ±0.22% at 0°C Accuracy: ±0.4°C at 0°C (DIN 43760 Ni 100)

5 - Simplex only
 6 - Duplex only
 7 - Not available for Probe type options 4, 5
 Note: See interchangeability tables for accuracy over the entire temperature range.

Code	Thermocouple element specifications
E	Chromel-Constantan
J	Iron-Constantan
K	Chromel-Alumel
T	Copper-Constantan
_G	Grounded: thermocouple junction internally grounded to case
_U	Ungrounded: thermocouple junction electrically isolated from case

Thermocouple accuracy:
 Standard tolerances per ASTM E230/E230M.

Insertion depth:

- If no thermowell or nipple/union extension, measured from thread engagement on fitting as shown in diagram above. If nipple/union extension but no thermowell, measured from thread engagement on nipple. If threaded thermowell, measured from end of thermowell threads as shown in diagram on page 5. If flanged thermowell, measured from face of flange as shown in diagram on page 5.
- Minimum: 35mm (only applies when no extension and/or no thermowell are specified).
- Maximum: 3048mm probe length. (Maximum insertion depth will vary, depending on selected options.)

Probe/Sensing Element Options

AS9	Specification
PD	Sensing element For RTD enter two letter code from table on left. For Thermocouple, enter E, J, K or T thermocouple type plus U or G for junction type as shown above.
100	Insertion depth (mm)
W	Leads per sensing element (colors shown are first element \ optional second element) Y ⁸ = 2 (1-red/1-white\1-yellow/1-blue) V ⁸⁹ = 2 (1-white/1-red\1-yellow/1-black) (EN60751) Z = 3 (1-red/2-white\1-blue/2-yellow) W = 3 (1-white/2-red\1-yellow/2-black) (EN60751) X = 4 (2-red/2-white\2-yellow/2-blue) U ⁹ = 4 (2-white/2-red\2-yellow/2-black) (EN60751) P = thermocouple (colors per ASTM E230/E230M)
AS900PD100W3A0X0X1N1 = Sample part number	

8 - Not available for Sensing element options CA, CC
 9 - Not available for simplex probe types.

Hazardous Area Sensor Assemblies

Select Optional Thermowell

Thermowell Specifications

1. Specify thermowell type

Code	Thermowell type
A	1" RF (Raised Face)
B	1.5" RF (Raised Face)
C	2" RF (Raised Face)
D	3" RF (Raised Face)
E	1" RTJ (Ring Type Joint)
F	1.5" RTJ (Ring Type Joint)
G	2" RTJ (Ring Type Joint)
H	3" RTJ (Ring Type Joint)
J	Threaded, reduced tip
K	Threaded, tapered
X0	No thermowell (skip 2a and 2b)

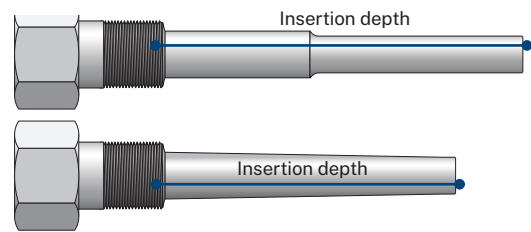
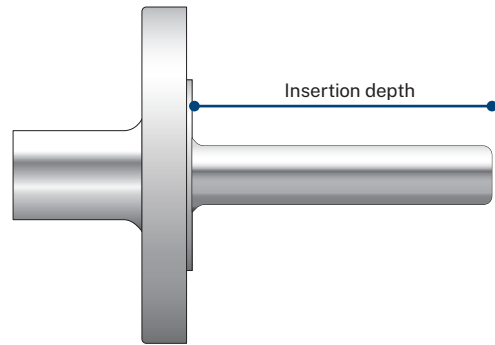

2a. If Flange mount thermowell, specify rating and shaft design

Code	Rating and shaft design
0	150# tapered
1	300# tapered
2	600# tapered
3	900#/1500# tapered
4	2500# tapered
5	150# straight
6	300# straight
7	600# straight
8	900#/1500# straight
9	2500# straight

2b. If Thread mount (code J or K) thermowell, specify process thread

Code	Process thread
0	1/2 - 14 NPT
1	3/4 - 14 NPT
2	1 - 11½ NPT
3	G 1/2

3. Specify thermowell material

Code	Material
X	No thermowell
A	Type 316/316L SST
B	Type 304 SST
J	Hastelloy C-276
K	Monel 400
N	Carbon Steel C1018

Thermowell Options

Code	Specification
X	Thermowell mounting type: select code from table 1 at left
0	Thermowell rating/shaft or thread: select code from table 2a or 2b at left
X	Thermowell material: select code from table 3 above
AS9000PD100W3A0X0X1N1 = Sample part number	

Hazardous Area Sensor Assemblies

Finish the part number by specifying your transmitter choice

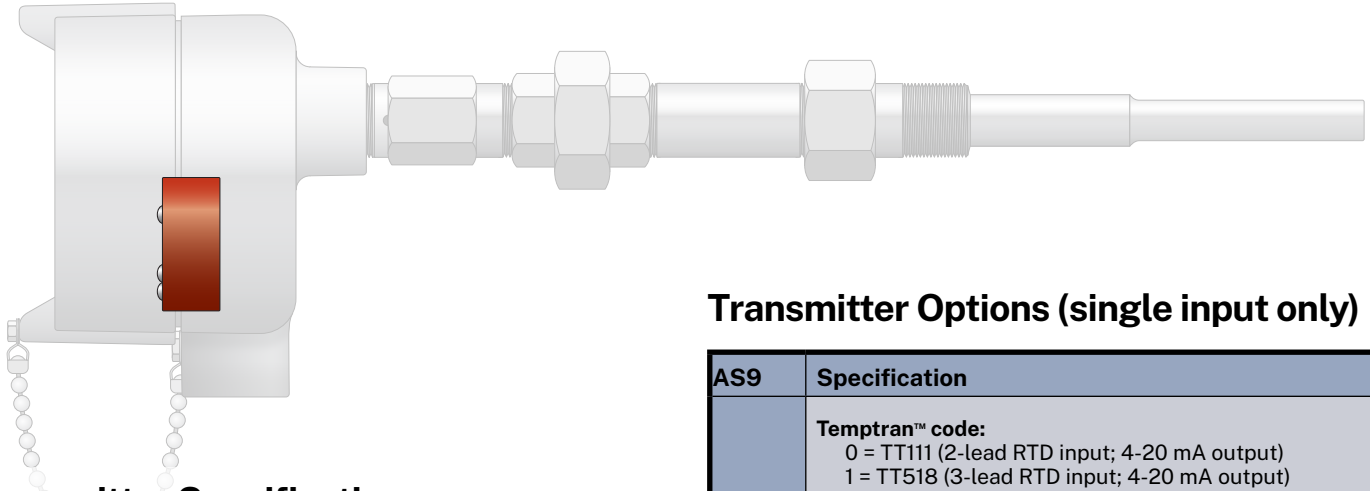

Transmitter Specifications

Note: TT111 series transmitter is certified only for North America use in explosionproof (XP) and flameproof (Ex d) applications

Temptran™ code	Base model number	Agency approvals
1	TT518	ATEX CSA (USA and Canada) IECEX
2	TT519	ATEX IECEX
6	TT520	ATEX CSA (USA and Canada) IECEX
7	TT521	ATEX CSA (USA and Canada) IECEX

Transmitter Options (single input only)

AS9	Specification
1	Temptran™ code: 0 = TT111 (2-lead RTD input; 4-20 mA output) 1 = TT518 (3-lead RTD input; 4-20 mA output) 2 = TT519 (thermocouple input; 4-20 mA output) 5 = TT246 (3-lead RTD input; 1-5 VDC output) 6 = TT520 (any input; 4-20 mA output) 7 = TT521 (any input; 4-20 mA output + HART®)
N	Temperature range code: For a list of Temperature range codes, download a Sensors Design Guide from Minco.com or contact Minco for additional range options.
1	Calibration (options 2, 3, 4 available for Simplex RTD configurations only): 1 = Calibrated to sensing element nominal values 2 = Match calibrated for ±0.75% of span system accuracy 3 = Match calibrated for ±0.50% of span system accuracy 4 ¹¹ = Match calibrated for ±0.20% of span system accuracy
AS9000PD100W3A0X0X1N1 = Sample part number	

¹¹ - System accuracy = ±0.20% of span or ±0.1°C, whichever is greater.

Calibration

Transmitters can be calibrated to nominal resistance values of the RTD (Calibration option 1). Total system error includes the tolerances of both the transmitter and the RTD sensor. Match calibration (Calibration options 2, 3, 4) uses actual resistance of the RTD to calibrate the transmitter. This effectively eliminates the sensor tolerance from system accuracy calculations. A calibration report with traceability to NIST and/or SI is provided with Calibration option 2, 3, or 4.

Calibration options 2, 3, and 4 are not available for thermocouples or duplex RTDs.