



► SECTION 4: INSTRUMENTS

- RTD and thermocouple Temptran™ transmitters provide accurate signals over thousands of feet.
- Fixed range, dip switch field rangeable or programmable
- 4-20mA output or HART® protocol
- Miniature, hockey puck, DIN rail and isolated versions
- High-accuracy calibration available matched to individual RTDs
- Controllers, indicators and alarms for precise monitoring and control

Section 4: Instruments

RTD transmitters	4-2 to 4-5, 4-8 to 4-9, 4-12 to 4-13	CT224 12-channel monitor.....	4-21 to 4-22
Thermocouple transmitters	4-6 to 4-7, 4-10 to 4-11, 4-14 to 4-15	CT424 Temperature Alarm/Monitor.....	4-23 to 4-24
Programmable transmitters.....	4-8 to 4-11	CT325 miniature DC temperature controller.....	4-25 to 4-26
Programmable transmitters	4-12 to 4-13	CT335 PC board mount temperature controller.....	4-27 to 4-28
HART® transmitters.....	4-14 to 4-15	CT435 PC board mount temperature controller.....	4-29 to 4-30
Temperature range table.....	4-16 to 4-17	CT15 controller/alarm.....	4-31 to 4-32
High accuracy calibration.....	4-18	CT16 temperature controller.....	4-33 to 4-34
Mounting accessories.....	4-18	CT15/CT16A accessories.....	4-35
Loop-powered indicators.....	4-19 to 4-20	CT425 Temperature controller.....	4-36 to 4-37

Miniature Temptran™ RTD Transmitters



TT111, TT211

Overview

- Two models:
 - TT111: UL-recognized component for Canada and United States.
 - TT211: Wider ambient rating; no agency approvals
- Optional high-accuracy calibration to Minco RTDs for improved accuracy; see next page and page 4-22 for more information.

Specifications

Output: 4 to 20 mA over specified range, linear with temperature.

Calibration accuracy: ±0.1% of span.

Linearity: Referenced to actual sensor temperature.

Platinum RTD input: ±0.1% of span.

Nickel and nickel-iron RTD input:

±0.25% of span for spans less than 100°C.

±0.25% of span per 100°C of span for spans greater than 100°C.

Adjustments: Zero and span, ±5% of span. Factory set.

Ambient temperature:

TT111: 0 to 50°C (32 to 122°F).

TT211: -25 to 85°C (-13 to 185°F).

Storage: -55 to 100°C (-67 to 212°F).

Ambient temperature effects:

±0.013% of span per °C.

±0.025% of span per °C for spans less than 55°C.

Warmup drift: ±0.1% of span max., with

$V_{supply} = 24$ VDC and $R_{loop} = 250 \Omega$.

Stable within 30 minutes.

Supply voltage: 8.5 to 35 VDC. Voltage effect ±0.001% of span per volt. Reverse polarity protected.

Maximum load resistance: The maximum allowable resistance of the signal carrying loop is:

$$R_{loop\ max} = \frac{V_{supply} - 8.5}{0.020\ \text{amps}}$$

Example: With supply voltage 24 VDC, maximum loop resistance is 775 Ω .

Minimum span: 27.8°C (50°F).

Connections:

Terminal block for wires AWG 22 to AWG 14.

Physical: Polycarbonate case, epoxy potted for moisture resistance.

Weight: 1.1 oz. (30 g).

Miniature RTD Transmitters

RTD input types

2-wire resistance thermometer:

Element		Code
Platinum (0.00392 TCR)	100 ∇ at 0°C	PA
Platinum (0.00391 TCR)	100 ∇ at 0°C	PB
Platinum (0.00385 TCR)	100 ∇ at 0°C	PD, PE
Platinum (0.00385 TCR)	1000 ∇ at 0°C	PF
Platinum (0.00375 TCR)	1000 ∇ at 0°C	PW
Nickel-iron (0.00518 TCR)	604 ∇ at 0°C	FA
Nickel-iron (0.00527 TCR)	1000 ∇ at 70°F	FB
Nickel-iron (0.00527 TCR)	2000 ∇ at 70°F	FC
Nickel (0.00672 TCR)	120 ∇ at 0°C	NA

Special high-accuracy calibration

For high system accuracy, specify transmitters with matched calibration. Temptrans match calibrated to a sensor are always ordered as assemblies. Common examples are shown in Section 1.

Specification and order options:

TT111	Model number: TT111 or TT211
PD	RTD element code from table
1	Output: 4 to 20 mA DC
C	Temperature range code starting on page 4-20 [Ex: C = 0 to 100°C (32 to 212°F)]
TT111PD1C = Sample part number	

Dimensions in inches (mm)

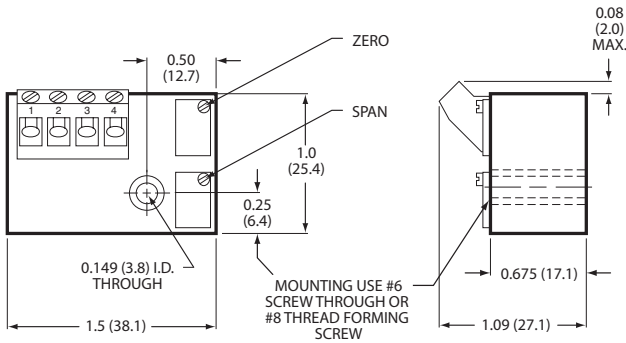

Wiring Diagram

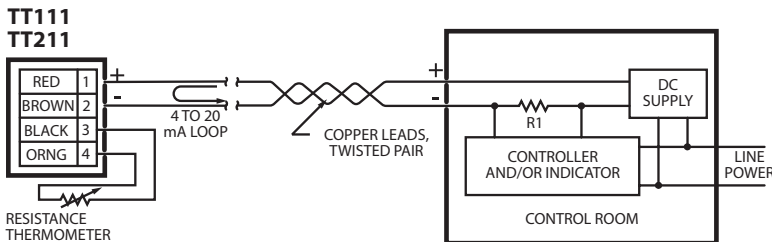

▼ = **STANDARD OPTIONS**
Specifications subject to change

TT246 RTD Transmitters



TT246 RTD Transmitter,
voltage output

Overview

Specify this rugged, accurate transmitter for process control and other industrial applications.

Model TT246 outputs 1 to 5 VDC proportional to temperature. It draws only 3 mA of quiescent current, making it ideal for solar or battery powered systems.

- 2 or 3-wire RTD input
- Ambient rated to 85°C (185°F)
- Fits DIN "B" style connection heads
- Optional high-accuracy calibration to Minco RTDs for improved accuracy; see next page and page 4-22 for more information.

Specifications

Output: Linear with temperature over specified range.
TT246: 1 to 5 VDC

Calibration Accuracy: ±0.1% of span (0.2% of span for spans less than 10 ∇)

Linearity: 0.1% of span, referenced to actual sensor temperature

Adjustments Zero and span, ±5% of span, non-interacting. Factory set.

Ambient temperature:

Operating: -40 to 85°C (-40 to 185°F)

Storage: -55 to 100°C (-67 to 212°F)

Ambient temperature effects:

±0.009% of span per °C

±0.014% of span per °C for spans less than 10 ∇

Warmup drift:

±0.1% of span max., with $V_{supply} = 24$ VDC and $R_{loop} = 250$ ∇.

Stable within 15 minutes.

Supply voltage:

TT246: 7.5 to 35 VDC

Voltage effect ±0.001% of span per volt.

Reverse polarity protected.

Supply current: 3mA max. with no load.

Maximum load resistance: The maximum allowable resistance of the signal carrying loop is:

$$R_{loop\ max} = \frac{V_{supply} - 10}{0.020\ \text{amps}}$$

Example: With supply voltage 24 VDC, maximum loop resistance is 700 ∇.

Minimum span: 10°C (18°F).

Minimum output current: 2.2 mA.

Maximum output current: 28 mA.

Leadwire compensation: (3-wire RTD) ±0.05% of span per ∇ up to 25 ∇ in each leg.

Hazardous atmospheres: May be used with Minco explosion-proof connection heads.

Connections: Terminal block for wires AWG 22 to AWG 14.

Physical: Polycarbonate case, epoxy potted for moisture resistance.

Weight: 2.0 oz. (57 g).

▼ = STANDARD OPTIONS

Specifications subject to change

TT246 RTD Transmitters

RTD input types

2 or 3-wire resistance thermometer:

Element		Code
Platinum (0.00392 TCR)	100 ∇ at 0°C	PA
Platinum (0.00391 TCR)	100 ∇ at 0°C	PB
Platinum (0.00385 TCR)	100 ∇ at 0°C	PD, PE
Platinum (0.00385 TCR)	1000 ∇ at 0°C	PF
Platinum (0.00375 TCR)	1000 ∇ at 0°C	PW
Copper (0.00427 TCR)	10 ∇ at 25°C	CA
Nickel-iron (0.00518 TCR)	604 ∇ at 0°C	FA
Nickel-iron (0.00527 TCR)	1000 ∇ at 70°F	FB
Nickel-iron (0.00527 TCR)	2000 ∇ at 70°F	FC
Nickel (0.00672 TCR)	120 ∇ at 0°C	NA

Special high-accuracy calibration

For high system accuracy, specify transmitters with matched calibration. Temptrans match calibrated to a sensor are always ordered as assemblies.

Specification and order options:

TT246	Model Number:
PB	RTD element code from table
1	
K	Temperature range code starting on page 4-20 [Ex: K = 0 to 200°C (32 to 392°F)]
TT246PB1K = Sample part number	

Dimensions in inches (mm)

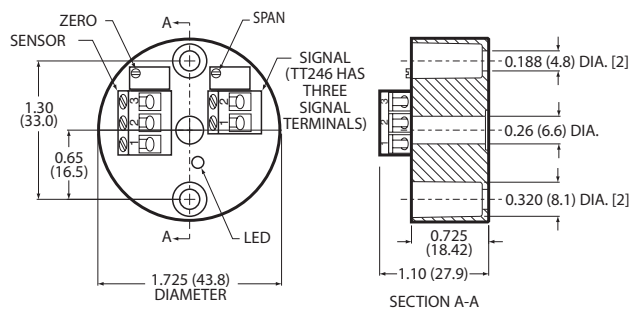

Wiring Diagram

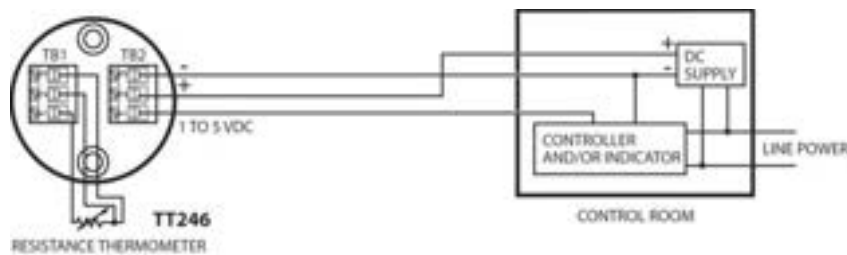

▼ = **STANDARD OPTIONS**
Specifications subject to change

TT205 Thermocouple Transmitters



TT205
Thermocouple Transmitter

Overview

Model TT205 interfaces with thermocouples for use in process control and other industrial applications.

Model TT205 offers superior performance in an economical and small package.

- Thermocouple input
- Fits DIN "B" style connection heads

Specifications

Output: 4 to 20 mA over specified range.

Accuracy: $\pm 0.2\%$ of span.

Linearity: Voltage linear.

The output signal is voltage linear (not temperature linear) and is intended for use with instruments which compensate for the nonlinear signal output of the thermocouples sensor.

Adjustments: Zero and span, $\pm 5\%$ of span, non-interacting. Factory set.

Warmup drift: $\pm 0.2\%$ of span max., with $V_{supply} = 24$ VDC and $R_{loop} = 250 \Omega$.
Stable within 15 minutes.

Supply voltage: 8.5 to 35 VDC
Voltage effect $\pm 0.001\%$ of span per volt.
Reverse polarity protected.

Maximum load resistance: The maximum allowable resistance of the signal carrying loop is:

$$R_{loop\ max} = \frac{V_{supply} - 10}{0.020\ \text{amps}}$$

Example: With supply voltage 24 VDC, maximum loop resistance is 700Ω .

Minimum output current: 1.5 mA.

Maximum output current: 28 mA.

Burnout: Downscale burnout standard; upscale optional.

Connections: Terminal block for wires AWG 22 to AWG 14.

Physical: Polycarbonate case, epoxy potted for moisture resistance.

Weight: 1.8 oz. (52 g).

▼ = STANDARD OPTIONS
Specifications subject to change

TT205 Thermocouple Transmitters

TT205

Ambient temperature:

Operating: -10 to 60°C (14 to 140°F).

Storage: -55 to 100°C (-67 to 212°F).

Ambient temperature effects: $\pm 0.036\%$ of span per °C.

Cold junction compensation drift: $\pm 0.05^\circ\text{C}$ per °C.

Minimum span: 150°C (270°F).

TT205 Dimensions in inches (mm)

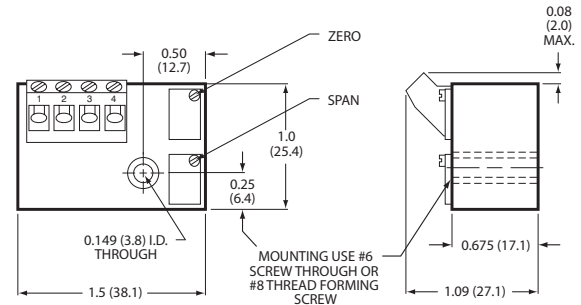

Specification and order options

TT205	Model Number: TT190: Round TT205: Rectangular
J	TC junction type: E = Chromel-Constantan J = Iron-Constantan K = Chromel-Alumel T = Copper-Constantan
U	U = Ungrounded junction (required)
1	Output: 4 to 20 mA DC
AN	Temperature range code starting on page 4-20 [Ex: AN = -17.8 to 148.9°C (0 to 300°F)]
TT205JU1AN = Sample part number	

Wiring Diagram

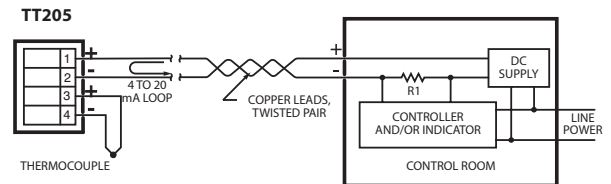

▼ = **STANDARD OPTIONS**
Specifications subject to change

TT508/TT518 Programmable Temperature Transmitter

Overview

This transmitter amplifies a signal from a RTD or linear resistance, and it turns the signal into a current which increases from 4 to 20 milliamperes as the temperature or input signal increases. This industry-standard 4-20mA signal travels thousands of feet over a pair of wires, ignoring electrical interference and bringing the temperature, accurately, into your computer or controller. Drawing power directly from the signal line, only 2 wires are needed for power and signal.

- RTD or Ohm input
- Accurate, Stable 4–20mA Output
- PC and field-programmable
- FM Approved Intrinsically Safe

Converts multiple inputs

Temperature measurement can be done with one of several RTD's: 100 ∇ , 1000 ∇ platinum, 100 ∇ Nickel and 1000 ∇ Nickel.

Because amplification and conversion of the input signal is performed within a few feet of the sensor, electrical interference in noisy environments is eliminated. The transmitter can be mounted at the field location in a standard DIN form B head or on a DIN rail inside a local box.

Applications

- Single temperature measurement

Configuration

The TT508/TT518 is delivered configured to the customer's specifications, including the transmitter's measurement range and RTD type.

PC Programming

The TT508/TT518 transmitter can be configured via a standard PC using a programming kit. It can be configured before installation or while installed in the process - even in hazardous areas. Communication is 2-way, so set-up and serial/tag numbers can be retrieved from the transmitter.



Specifications

Ambient temperature range: -40°C to +85°C

Supply voltage: 8 -30 VDC

Warm-up time: 5 min.

Communication interface: PC Interface/Loop Link

Signal/noise ratio: Min. 60 dB

Response time (programmable): 0.33 sec. to 60 sec.

Update time: 135 msec.

Calibration temperature: 20 to 28°C

Effect of supply voltage change: < 0.005% of span/ VDC

EMC-Immunity influence: < $\pm 0.5\%$ of span

Vibration: IEC 600 68-2-6 Test FC

Lloyd's specification no. 1: 4 g / 2 - 100 Hz

Max. wire size: AWG14 (1.5 mm²)

Air humidity: 0 - 95% RH

Dimensions: 1.73 x 0.84 in (44 x 20.2mm)

Tightness (enclosure/terminal): IP 68 / IP00

Weight: 50g

▼ = **STANDARD OPTIONS**
Specifications subject to change

TT508/TT518 Programmable Temperature Transmitter

Inputs (common specifications)

Max. offset: 50% of selected max. value

Cable resistance per wire (max.): 10 ∇

Sensor current: >0.2mA, <0.4mA

Effect of sensor cable resistance:
(3-wire): < 0.002 ∇/∇

Input:

Type	Minimum Value	Maximum Value	Minimum Span
PD (Pt100)	-200°C	+850°C	25°C
PF (Pt1000)	-200°C	+850°C	25°C
Linear Res.	0 ∇	10000 ∇	30 ∇

Basic accuracy:

PD/PF (Pt100/1000): <±0.3°C
Linear Resistance: <±0.2 ∇

Temperature coefficient:

PD/PF (Pt100/1000): <±0.01°C/°C
Linear Resistance: <±20m ∇ /°C

Current output:

Signal range: 4 - 20 mA
Min. signal range: 16 mA
Load resistance : < (Vsup. - 8) / 0.023 [∇]
Load stability: ± 0.01% of span / 100 ∇

Sensor error detection:

Programmable: 3.5 - 23 mA, or no action
Namur NE43 Downscale/Upscale: 3.5 mA/ 23 mA

Approvals:

EMC: EN 61326-1
ATEX.: KEMA 03ATEX1535
FM: 2D5A7
CSA: 1125003
GOST R: Yes
GOST Ex: Yes
DNV Marine: Stand. F. Certification No. 2.4

Input

The input type is selected to be one of these types:

- RTD (2 or 3-wire): PT100, PT1000

Output

The 4-20 mA output follows the TT518 input configuration, reflecting the temperature and/or resistance. The unit is protected against polarity reversal. The output signal action can be reversed with respect to the input signal. Sensor and/or cable errors can be programmed to cause the output to go to a fixed value.

Specification and order options:

TT518	Model Number: TT518 Approvals, fits .236" Probe Max TT508 No Approvals, fits .250" Probe Max
PD	Sensor Type: PD = 100 ∇ Platinum RTD (0.00385) PF = 1000 ∇ Platinum RTD (0.00385)
(-25/200)	Ranging: Specify temperature range in either °C or °F. For example, -25° to +200°C = 4 to 20 mA.
C	Display Units: C = Celsius F = Fahrenheit
1	Calibration: 1 = Nominal 2 = Matched to sensor ±0.75% of span For other calibration options, contact Minco
Z	Sensor Leads: (3 Lead Recommended) Y = 2-lead RTD (Supplied with jumper wire to connect terminals 3 and 4) Z = 3-lead RTD
TT518PD(-25/200)C1Z : Sample part number	

Note: TT508 does not carry any external approvals, but does allow a .250" probe to pass through its center hole

∇ = STANDARD OPTIONS
Specifications subject to change



TT509/TT519 Programmable Temperature Transmitter

Overview

This transmitter amplifies a signal from a thermocouple, and it turns the signal into a current which increases from 4 to 20 milliamperes as the temperature or input signal increases. This industry-standard 4-20mA signal travels thousands of feet over a pair of wires, ignoring electrical interference and bringing the temperature, accurately, into your computer or controller. Drawing power directly from the signal line, only 2 wires are needed for power and signal.

- Thermocouple or Voltage Input
- Accurate, Stable 4–20mA Output
- PC and field-programmable
- Galvanically Isolated

Converts multiple inputs

Temperature measurement can be done with multiple thermocouple types, which boast high operating temperature ranges.

Because amplification and conversion of the input signal is performed within a few feet of the sensor, electrical interference in noisy environments is eliminated. The transmitter can be mounted at the field location in a standard DIN form B head or on a DIN rail inside a local box.

Applications

- Single temperature measurement

Configuration

The TT509/TT519 is delivered configured to the customer's specifications, including the transmitter's measurement range and thermocouple type.

PC programming

The TT509/TT519 transmitter can be configured via a standard PC using a programming kit. It can be configured before installation or while installed in the process - even in hazardous areas. Communication is 2-way, so set-up and serial/tag numbers can be retrieved from the transmitter.



Specifications

Ambient temperature range: -40°C to +85°C

Supply voltage: 7.2 -30 VDC

Warm-up time: 5 min.

Communication interface: PC Interface/Loop Link

Signal/noise ratio: Min. 60 dB

Response time (programmable): 1 sec. to 60 sec.

Update time: 440 msec.

Calibration temperature: 20 to 28°C

Effect of supply voltage change: < 0.005% of span/ VDC

EMC-Immunity influence: < ±0.5% of span

Electrical Isolation, test/operation: 1.5kVAC/50VAC

Vibration: IEC 600 68-2-6 Test FC

Lloyd's specification no. 1: 4 g / 2 - 100 Hz

Max. wire size: AWG14 (1.5 mm²)

Air humidity: 0 - 95% RH

Dimensions: 1.73 x 0.84 in (44 x 20.2mm)

Tightness (enclosure/terminal): IP 68 / IP00

Weight: 50g

▼ = **STANDARD OPTIONS**
Specifications subject to change

TT509/TT519 Programmable Temperature Transmitter

Inputs (common specifications)

Max. offset: 50% of selected max. value

Input:

Type	Minimum Value	Maximum Value	Minimum Span
E	-100°C	+1000°C	50°C
J	-100°C	+1200°C	50°C
K	-180°C	+1372°C	50°C
T	-200°C	+400°C	50°C
B	+400°C	+1820°C	100°C
N	-180°C	+1300°C	50°C
R	-50°C	+1760°C	100°C
S	-50°C	+1760°C	100°C

Basic accuracy:

TC type E, J, K, L, N, T: $<\pm 1^\circ\text{C}$

TC type B, R, S: $<\pm 2^\circ\text{C}$

Voltage: $\nabla\pm 10\mu\text{V}$

Temperature coefficient:

TC type E, J, K, T: $<\pm 0.05^\circ\text{C}/^\circ\text{C}$

TC type B, N, R, S: $<\pm 0.2^\circ\text{C}/^\circ\text{C}$

Voltage: $<\pm 1\mu\text{V}/^\circ\text{C}$

Cold Junction Compensation: $<\pm 1^\circ\text{C}$

Current output:

Signal range: 4 - 20 mA

Min. signal range: 16 mA

Load resistance : $< (V_{\text{sup}} - 7.2) / 0.023 [\nabla]$

Load stability: $\pm 0.01\%$ of span / 100 ∇

Sensor error detection:

Programmable: 3.5 - 23 mA, or no action

Namur NE43 Downscale/Upscale: 3.5 mA/ 23 mA

Approvals:

EMC: EN 61326-1

ATEX.: KEMA 06ATEX0062

GOST R: Yes

GOST Ex: Yes

DNV Marine: Stand. F. Certification No. 2.4

Input

The input type is selected to be one of these types:

- Type E, J, K, T, B, N, R, S Thermocouple
- Voltage Input

Output

The 4-20 mA output follows the TT519 input configuration, reflecting the temperature. The unit is protected against polarity reversal. The output signal action can be reversed with respect to the input signal. Sensor and/or cable errors can be programmed to cause the output to go to a fixed value.

Specification and order options:

TT519	Model Number: TT519 Approvals, fits .236" Probe Max TT509 No Approvals, fits .250" Probe Max
K	Sensor Type: E=Type E Thermocouple J=Type J Thermocouple K=Type K Thermocouple T=Type T Thermocouple B=Type B Thermocouple N=Type N Thermocouple R=Type R Thermocouple S=Type S Thermocouple V = Voltage Input
(-25/200)	Ranging: Specify temperature range in either °C or °F. For example, -25° to +200°C = 4 to 20 mA.
C	Display Units: C = Celsius F = Fahrenheit MV = Millivolts
1	Calibration: 1 = Nominal
Y	Sensor Leads: Y = 2-lead
TT519K(-25/200)C1Y: Sample part number	

Note: TT509 does not carry any external approvals, but does allow a .250" probe to pass through its center hole

▼ = STANDARD OPTIONS

Specifications subject to change



Programmable Transmitters

Overview

Models TT520 and TT530 are programmable transmitters designed for process control and other applications. Both transmitters use a 4-20mA current loop output and are PC programmable to accept a signal from a thermocouple, a Resistance Temperature Detector (RTD), or a millivolt signal. Model TT520 can be mounted at the field location in a standard DIN form B head or on a DIN rail inside a local box (with an AC807 Minco DIN rail adapter), whereas model TT530 can be mounted vertically or horizontally on a DIN rail.

- T/C, RTD, or mV input
- Accurate, Stable 4-20mA Output
- PC and field-programmable
- Galvanically isolated
- FM Approved Intrinsically Safe
- Single temperature measurement

Specifications

Common Specifications:

Supply voltage: 7.2 - 30 VDC

Temperature coefficient: $\pm 0.01\%$ of span/ °C

Effect of supply voltage change: $< 0.005\%$ of span/ VDC

Max. wire size: AWG14 (1.5 mm²)

Air humidity: 0 - 95% RH

Dimensions:

TT520: Ø1.73 x 0.84 in (Ø44 x 20.2mm)

TT530: 4.29 x .093 x 4.09 in (109 x 23.5 x 104mm)

AC205817 USB Loop Link Programmer:

TT520 and TT530 transmitters are preconfigured for ease of use. The AC205817 USB Loop Link Programmer allows the user to reconfigure the transmitter using free, Windows-based software.

Tightness (enclosure/terminal):

TT520: IP 68 / IP00

TT530: IP50 / IP20

Weight:

TT520: 50 g

TT530: 145 g



TT520



TT530

TC Input:

Minimum measurement range:

Type E, J, K, T: 50°C

Max. offset: 50% of selected max. value

Basic accuracy:

Type E, J, K, T: $\leq 1^\circ\text{C}$

Cold junction compensation (CJC): $\leq 1.0^\circ\text{C}$

Temperature coefficient:

Type E, J, K, T: $\leq \pm 0.05^\circ\text{C} / ^\circ\text{C}_{\text{amb}}$

Sensor error detection: yes

RTD type	Minimum value	Maximum value	Minimum span.
PD (Pt100)	-200°C	+850°C	25°C
PF (Pt1000)	-200°C	+850°C	25°C

RTD-input:

Basic accuracy PD/PF (Pt100/1000): $\leq \pm 0.2^\circ\text{C}$

Temperature coefficient: $\leq \pm 0.01^\circ\text{C} / ^\circ\text{C}$

Current output:

Signal range: 4 - 20 mA

Load resistance: $< (V_{\text{sup.}} - 7.2) / 0.023 [\nabla]$

Intrinsic Safety data: FM Approved Intrinsically Safe for Class 1, Div. 1, Groups A-D, Entity Approval

V_{max} : 30.0 VDC

C_i : 1 nF

I_{max} : 120 mADC

L_i : 10 #H

P_{max} : 0.84 W

Europe: ATEX II 1 G

Meets these European requirements:

EMC 2004/108/EC: Standard EN 61326

▼ = STANDARD OPTIONS

Specifications subject to change

Programmable Transmitters

Specifications and order options

TT520	Model Number: TT520 Temperature Transmitter TT530 DIN Rail Temperature Transmitter
PD	Sensor Type: PD = 100Ω Platinum RTD (0.00385) PF = 1000Ω Platinum RTD (0.00385) E = Type E Thermocouple J = Type J Thermocouple K = Type K Thermocouple T = Type T Thermocouple
(-25/200)	Temperature Range: Specify temperature range in either °C or °F. For example, -25° to +200°C = 4 to 20 mA.
C	Temperature Units: C = Celsius F = Fahrenheit
1	Calibration: 1 = Nominal 2 = Matched to sensor ±0.75% span For other calibration options, contact Minco
Y	Sensor Leads: Y = 2-lead RTD (or thermocouple) Z = 3-lead RTD X = 4-lead RTD
TT520PD(-25/200)C1Y = Sample part number	

Dimensions in inches (mm)

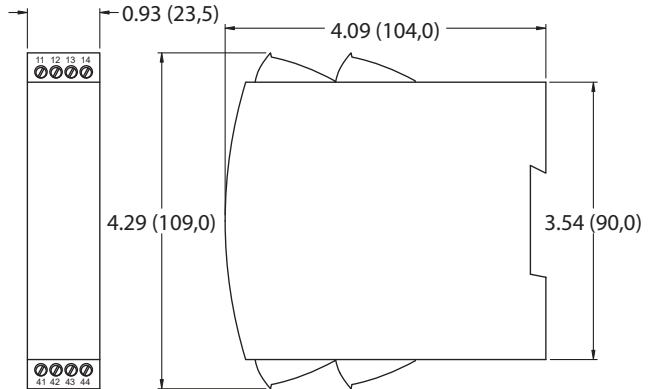

Dimensions in inches (mm)

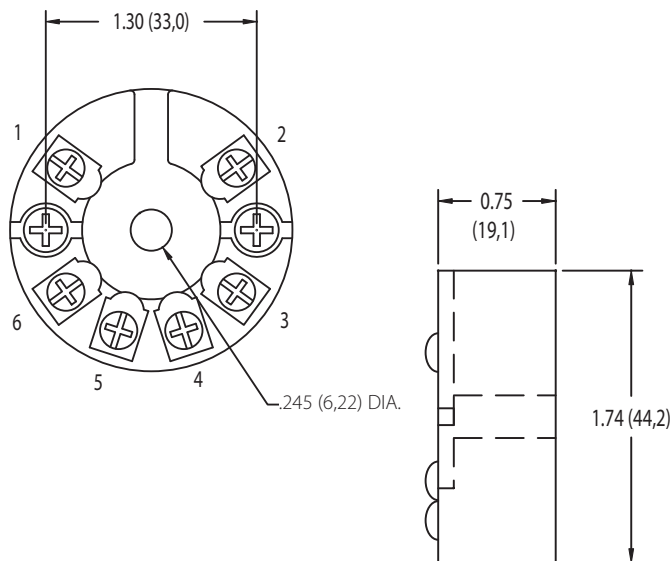

Wiring Diagrams

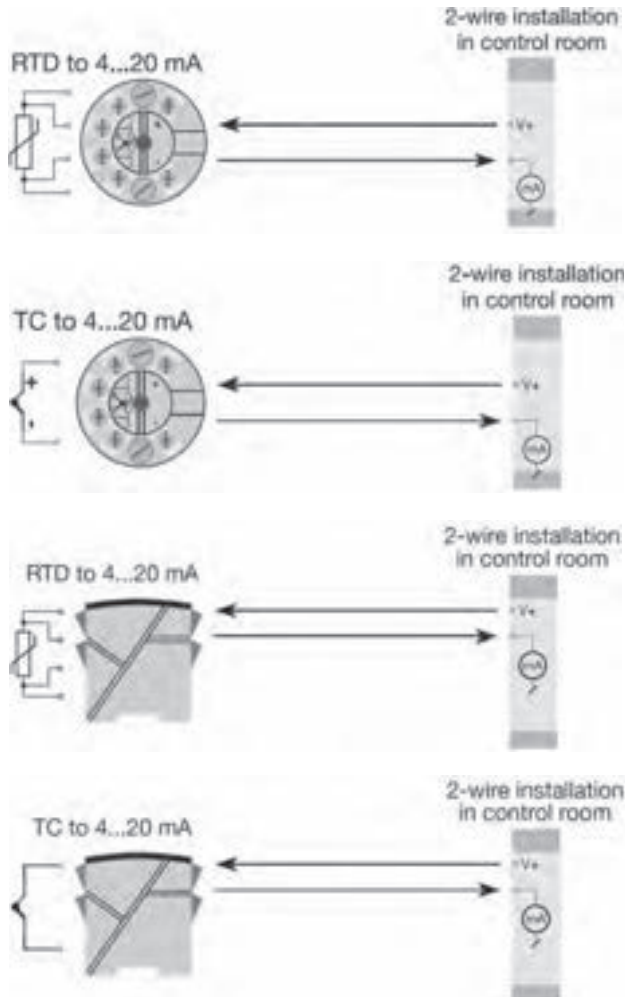

Specifications subject to change

Programmable Transmitters w/ HART® Protocol



TT511/TT521

TT531

Overview

Models TT511, TT521 and TT531 are programmable transmitters designed for process control and other applications. All three models use HART® communication protocol and are PC programmable to accept a signal from a thermocouple, a Resistance Temperature Detector (RTD), or a millivolt signal. Model TT511/TT521 transmitter can be mounted at the field location in a standard DIN form B head or on a DIN rail inside a local box (with an AC807 Minco DIN rail adapter). Model TT531 can be mounted vertically or horizontally on a DIN rail.

- T/C, RTD, or mV input
- HART® 7/5 Communication Protocol
- PC and field-programmable
- Galvanically isolated
- FM Approved Intrinsically Safe
- Single temperature measurement
- Difference temperature measurement
- Average temperature measurement

HART® Communication

By way of 2-wire HART® communication between the process computer and the TT511, TT521 or TT531, the transmitter is programmable, readable, and controllable.

- Up to 63 transmitters can be controlled in a multidrop system. (Parallel connection of all transmitters on 2 wires).
- Set-up, configuration and control can be done from a central monitoring room.

When each transmitter is connected to a 2-wire cable, a standard 4-20 mA signal can be used at the same time as the HART® communication.

Specifications

Common Specifications:

Supply voltage: 8.0 - 30 VDC

Specifications subject to change

Communication interface: HART® 7/5 and PC interface

Temperature coefficient: $< \pm 0.005\%$ of span/ °C

Effect of supply voltage change: $< 0.005\%$ of span/ VDC

Max. wire size: AWG14 (1.5 mm²)

Air humidity: 0 - 95% RH

Dimensions:

TT511/TT521: Ø1.73 x 0.84 in (Ø44 x 20.2mm)

TT531: 4.29 x .0.93 x 4.09 in (109 x 23.5 x 104mm)

Tightness (enclosure/terminal):

TT511/TT521: IP 68 / IP00 TT531: IP50 / IP20

Weight:

TT511/TT521: 50 g

TT531: 145 g

AC205817 USB Loop Link Programmer:

TT511/TT521 and TT531 transmitters are preconfigured for ease of use. The AC205817 USB Loop Link Programmer allows the user to reconfigure the transmitter using free, Windows-based software.

TC Input:

Minimum measurement range:

Type E, J, K, T : 50°C

Max. offset: 50% of selected max. value

Basic accuracy:

Type E, J, K, T : $\pm 0.5^\circ\text{C}$

Cold junction compensation (CJC): $\pm 1.0^\circ\text{C}$

Temperature coefficient:

Type E, J, K, T : $\pm 0.025^\circ\text{C} / ^\circ\text{C}_{\text{amb}}$

Sensor error detection: yes

RTD-input:

RTD type	Minimum value	Maximum value	Minimum span.
PD (Pt100)	-200°C	+850°C	25°C
PF (Pt1000)	-200°C	+850°C	25°C

Basic accuracy PD/PF (Pt100/1000): $\leq \pm 0.1^\circ\text{C}$

Temperature coefficient: $\leq \pm 0.005^\circ\text{C} / ^\circ\text{C}$

Current output:

Signal range: 4 - 20 mA

Load resistance: $< (V_{\text{sup}} - 8) / 0.023 [\text{V}]$

Intrinsic Safety data: FM Approved Intrinsically Safe for Class 1, Div. 1, Groups A-D, Entity Approval

V_{max} : 30.0 VDC C_i : 1 nF

I_{max} : 120 mA DC L_i : 10 #H

P_{max} : 0.84 W

Europe: ATEX II 1 G

Meets these European requirements:

EMC 2004/108/EC: Standard EN 61326-1

Programmable Transmitters w/ HART® Protocol

Specifications and order options

TT521	Model Number: TT511 No Approvals, Temperature Transmitter with HART® protocol, fits .250" Probe Max TT521 Temperature Transmitter with HART® Protocol, fits .236" Probe Max TT531 DIN Rail Temperature Transmitter with HART® Protocol
PD	Sensor Type: PD = 100Ω Platinum RTD (0.00385) PF = 1000Ω Platinum RTD (0.00385) E = Type E Thermocouple J = Type J Thermocouple K = Type K Thermocouple T = Type T Thermocouple
(-25/200)	Temperature Range: Specify temperature range in either °C or °F. For example, -25° to +200°C = 4 to 20 mA.
C	Temperature Units: C = Celsius F = Fahrenheit
1	Calibration: 1 = Nominal 2 = Matched to sensor ±0.75% span For other calibration options, contact Minco
Y	Sensor Leads: Y = 2-lead RTD (or thermocouple) Z = 3-lead RTD X = 4-lead RTD
TT521PD(-25/200)C1Y = Sample part number	

Wiring Diagrams

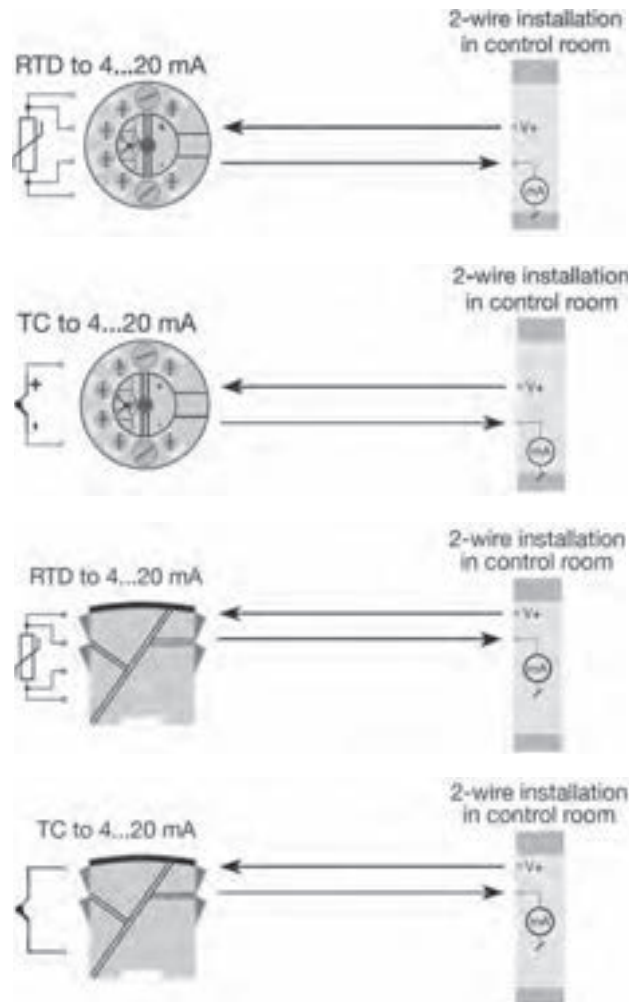

Dimensions in inches (mm)

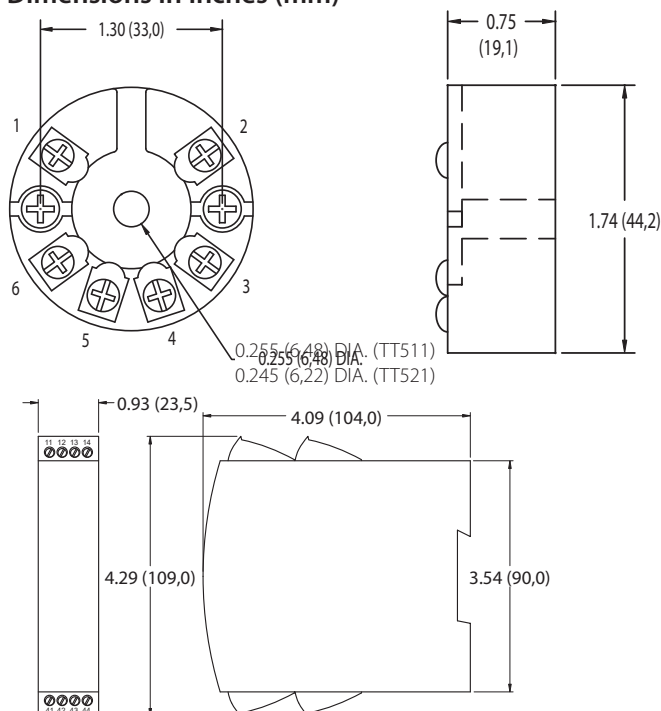

HART® Multidrop Wiring Diagram

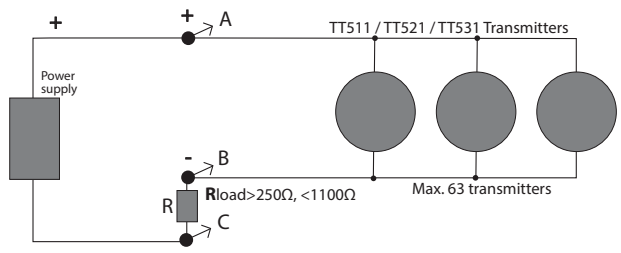

▼ = STANDARD OPTIONS
 Specifications subject to change



Temptran™ Temperature Ranges

Below is a list of commonly selected Temptran temperature ranges. The endpoints of the temperature range correspond to the Temptran's 4 and 20 mA signals. Choose the smallest possible span for best accuracy. Be sure to check the temperature limits of the sensor you specify.

If you do not find the temperature range required by your application, go to www.minco.com for a complete list of temperature ranges. Custom ranges are also available for a small setup charge. Contact Minco Sales and Customer Service for more information.

For more temperature ranges (over 400 options) contact Minco Sales and Customer Service

Range code	Temperature Range				RTD Temptrons			Thermocouple Temptrons	
	Zero °F	Span °F	Zero °C	Span °C	TT111, TT115, TT211, TT829		TT246, TT220	TT221	TT205
					Platinum elements*	Other elements	Elements	T/C types	T/C types
MH	-328	-148	-200.0	-100.0	PA PB PD PE				
HG	-325	100	-198.3	37.8	PA PB PD PE PF PW			JT	
QS	-300	150	-184.4	65.6			PA PB PD PE		
EZ	-148	32	-100.0	0.0	PA PB PD PE PF PW		PA PB PD PE		
LN	-148	212	-100.0	100.0	PA PB PD PE				
SA	-140	100	-95.6	37.8			PA PB PD PE		
UL	-103	752	-75.0	400.0				K	
M	-58	122	-50.0	50.0	PA PB PD PE PF PW		PA PB PD PE		
EO	-58	212	-50.0	100.0	PA PB PD PE	NA	PA PB PD PE	T	ET
JD	-58	302	-50.0	150.0	PA PB PD PE		PA PB PD PE	J	
MR	-58	500	-50.0	260.0			PA PB PD PE CA NA		
SD	-50	100	-45.6	37.8	PA PB PD PE				
MI	-50	150	-45.6	65.6	PA PB PD PE		PA PB PD PE	T	
AI	-50	275	-45.6	135.0	PA PB PD PE PF PW	FB FC FL NA	PA PB PD PE		
MS	-50	650	-45.6	343.3	PA PB PD PE		PA PB PD PE		
AD	-40	120	-40.0	48.9	PA PB PD PE	FB FC	PA PB PD PE		
AK	-40	140	-40.0	60.0	PA PB PD PE PU		PA PB PD PE		
BE	-40	160	-40.0	71.1	PA PB PD PE	FB	PA PB PD PE		
GH	-40	212	-40.0	100.0	PA PB PD PE		PA PB PD PE		
UE	-40	302	-40.0	150.0	PA PB PD PE		PA PB PD PE		
L	-30	120	-34.4	48.9	PA PB PD PE PF PW	FB FC			
AS	-30	130	-34.4	54.4	PA PB PD PE PF PW	FB	PA PB PD PE		
R	-30	150	-34.4	65.6	PA PB PD PE	FB FC	PA PB PD PE		
DN	-22	122	-30.0	50.0	PA PB PD PE		PA PB PD PE		
EE	-22	302	-30.0	150.0	PA PB PD PE		PA PB PD PE		
DO	-20	120	-28.9	48.9	PA PB PD PE PF PW	ND	PA PB PD PE		
EN	-20	140	-28.9	60.0	PA PB PD PE PF PW	FB	PA PB PD PE		
B	-20	180	-28.9	82.2	PA PB PD PE	FB FC NA	PA PB PD PE CA		
BP	-4	104	-20.0	40.0	PA PB PD PE	FC	PA PB PD PE		
SH	-4	122	-20.0	50.0	PA PB PD PE				
DB	-4	212	-20.0	100.0	PA PB PD PE		PA PB PD PE		
JZ	0	65	-17.8	18.3	PA PB PD PE		PA PB PD PE		
S	0	100	-17.8	37.8	PA PB PD PE PF PG PW	FB	PA PB PD PE PW		
JH	0	120	-17.8	48.9	PA PB PD PE PF PW	FC	PA PB PD PE		
HD	0	130	-17.8	54.4	PA PB PD PE PF PW		PA PB PD PE		
DV	0	150	-17.8	65.6	PA PB PD PE	FB	PA PB PD PE		
EI	0	160	-17.8	71.1	PA PB PD PE				
AC	0	200	-17.8	93.3	PA PB PD PE PF PW	FB NA	PA PB PD PE CA	EJKT	T
EY	0	250	-17.8	121.1	PA PB PD PE PF PW	NA	PA PB PD PE	JK	JKT
AN	0	300	-17.8	148.9	PA PB PD PE PF PW	FB FC NA	PA PB PD PE CA NA	EJKT	K
JA	0	350	-17.8	176.7	PA PB PD PE		PA PB PD PE	KJ	
DS	0	400	-17.8	204.4	PA PB PD PE	NA	PA PB PD PE CA NA	JK	
AG	0	500	-17.8	260.0	PA PB PD PE PF PW	NA	PA PB PD PE CA	EJT	JKT
QN	0	550	-17.8	287.8	PA PB PD PE		PA PB PD PE		
AB	0	600	-17.8	315.6	PA PB PD PE PF PW	NA	PA PB PD PE	EJK	J
AA	0	800	-17.8	426.7	PA PB PD PE PF PW		PA PB PD PE	J	JK
BZ	0	1000	-17.8	537.8	PA PB PD PE		PA PB PD PE	JK	EJ

* Element codes (PA, PB, PD, PE, etc.) are defined in the Resistance/Temperature Tables on page 11-11

Specifications subject to change



Temptran™ Temperature Ranges

For more temperature ranges (over 400 options) go to www.minco.com

Range code	Temperature Range				RTD Temptrans				Thermocouple Temptrans	
	Zero °F	Span °F	Zero °C	Span °C	TT111, TT115, TT211, TT829		TT246, TT220		TT221	TT205
					Platinum elements*	Other elements	Elements		T/C types	T/C types
HU	0	1300	-17.8	704.4					K	
BY	14	104	-10.0	40.0	PA PB PD PE		PA PB PD PE			
AJ	14	122	-10.0	50.0	PA PB PD PE		PA PB PD PE			
AP	20	70	-6.7	21.1	PA PB PD PE PF PW		PA PB PD PE			
GV	20	100	-6.7	37.8	PA PB PD PE PF PW		PA PB PD PE			
A	20	120	-6.7	48.9	PA PB PD PE PF PW	FA FB FC NA	PA PB PD PE PF			
HE	20	240	-6.7	115.6	PA PB PD PE					
AF	20	320	-6.7	160.0	PA PB PD PE	FA FB				
QE	22	122	-5.6	50.0	PA PB PD PE					
GW	23	131	-5.0	55.0	PA PB PD PE					
U	30	80	-1.1	26.7	PA PB PD PE PF PW	FB FC	PA PB PD PE			
DA	30	90	-1.1	32.2	PA PB PD PE PF PW	FC	PA PB PD PE			
DP	30	100	-1.1	37.8	PA PB PD PE PF PW					
BI	30	130	-1.1	54.4	PA PB PD PE PF PW		PA PB PD PE PF PW			
DQ	30	150	-1.1	65.6	PA PB PD PE	FB	PA PB PD PE			
KK	30	180	-1.1	82.2	PA PB PD PE					
EV	30	230	-1.1	110.0	PA PB PD PE		PA PB PD PE			
BN	30	240	-1.1	115.6	PA PB PD PE PF PW	FB	PA PB PD PE			
BJ	30	250	-1.1	121.1	PA PB PD PE PF PW	NA	PA PB PD PE FA			
GQ	32	100	0.0	37.8	PA PB PD PE PF PW		PA PB PD PE			
EG	32	104	0.0	40.0	PA PB PD PE PF PW		PA PB PD PE			
N	32	122	0.0	50.0	PA PB PD PE PF PW	FB FC	PA PB PD PE			
HL	32	167	0.0	75.0	PA PB PD PE		PA PB PD PE			
C	32	212	0.0	100.0	PA PB PD PE PF PW	FB FC NA	PA PB PD PE CA NA	JT		
QR	32	257	0.0	125.0	PA PB PD PE					
DL	32	280	0.0	137.8	PA PB PD PE		PA PB PD PE			
J	32	302	0.0	150.0	PA PB PD PE PF PU PW	FC NA	PA PB PD PE CA	J	J	
K	32	392	0.0	200.0	PA PB PD PE PU	NA	PA PB PD PE CA	JK	J	
LX	32	400	0.0	204.4	PA PB PD PE					
BW	32	482	0.0	250.0	PA PB PD PE	NA	PA PB PD PE	EJKT	J	
LF	32	572	0.0	300.0	PA PB PD PE		PA PB PD PE	JT		
JW	32	932	0.0	500.0	PA PB PD PE		PA PB PD PE	JK	K	
HA	32	1112	0.0	600.0	PA PB PD PE PF PW			K		
GF	32	1472	0.0	800.0	PA PB PD PE		PA PB PD PE	K	K	
SG	33.8	123.8	1.0	51.0	PA PB PD PE					
H	40	90	4.4	32.2	PA PB PD PE PF PW	FB	PA PB PD PE			
BU	40	100	4.4	37.8	PA PB PD PE PF PW					
QL	40	120	4.4	48.9	PF PW	FC				
BK	40	140	4.4	60.0	PA PB PD PE PF PW	FB	PA PB PD PE			
KH	40	240	4.4	115.6	PA PB PD PE PF PW		PA PB PD PE			
KP	42	92	5.6	33.3	PA PB PD PE					
DU	45	95	7.2	35.0	PA PB PD PE		PA PB PD PE			
DX	50	100	10.0	37.8	PA PB PD PE PF PW		PA PB PD PE			
AH	50	110	10.0	43.3	PA PB PD PE	FB	PA PB PD PE			
ED	50	120	10.0	48.9	PA PB PD PE PF PW	FB				
V	50	150	10.0	65.6	PA PB PD PE PF PW	FA FB NA	PA PB PD PE			
AV	50	230	10.0	110.0	PA PB PD PE PF PW		PA PB PD PE	J		
BF	50	250	10.0	121.1	PA PB PD PE PF PW		PA PB PD PE PF PW	ET		
AO	50	300	10.0	148.9	PA PB PD PE		PA PB PD PE CA FA			
KF	50	400	10.0	204.4	PA PB PD PE		PA PB PD PE			
D	70	220	21.1	104.4	PA PB PD PE PF PW	FB FC	PA PB PD PE			
E	100	500	37.8	260.0	PA PB PD PE PF PW		PA PB PD PE			
BH	122	302	50.0	150.0	PA PB PD PE		PA PB PD PE	T		
BL	200	500	93.3	260.0	PA PB PD PE PF PW			K		

* Element codes (PA, PB, PD, PE, etc.) are defined in the Resistance/Temperature Tables on page 11-11

Specifications subject to change



Temptran™ Calibration & Accessories

Special high-accuracy calibration

Standard transmitters can be calibrated to the nominal resistance values of the RTD at the zero and span points. Total system error includes the tolerance of both the transmitter and the RTD sensor. If you order Minco Temptrons calibrated to the actual resistance of the RTD (traceable to NIST), this effectively eliminates the sensor tolerance from the system accuracy specifications.

Temptrons match calibrated to a sensor are always ordered as assemblies. Common examples are shown in Section 1.

Free NIST traceability

With each matched sensor/transmitter set, Minco sends you calibration data traceable to the National Institute of Standards & Technology. This helps your process comply with ISO 9001 and other quality standards.

Recalibration

Minco prints RTD resistance values right on the Temptran label to simplify recalibration. You simply connect a resistance decade box or "RTD simulator" in place of the RTD, dial in the correct values, and adjust zero and span.

Because Minco platinum RTDs are extremely stable in typical installations (0.1°C or better), you can trust the printed values for many years.

MINCO MPS, MIN, USA	MODEL	TEMPTRAN™	
	D/C: 9614		
	100 OHM PLATINUM RTD		
	4mA= 20.0°F= -6.7°C=	97.932Ω	
	20mA= 120.0°F= 48.9°C=	118.969Ω	

RTD resistances are printed on Temptran labels for easy recalibration of zero and span. A standard Temptran shows nominal values.

MINCO MPS, MIN, USA	MODEL	TEMPTRAN™	
	D/C: 9614 S/N: 103		
	100 OHM PLATINUM RTD		
	4mA= 20.0°F= -6.7°C=	97.427Ω	
	20mA= 120.0°F= 48.9°C=	118.988Ω	

A specially calibrated Temptran shows actual resistance of the serialized, connected RTD.

Temptran Accessories

DIN rail mounting

For easy installation in instrument cabinets. Adapters fit all Temptran models. Specify length when ordering rails.

Model	Description
AC805	DIN EN50022 Rail
AC807	Adapter for EN50022



Temptrons mounted to DIN rail

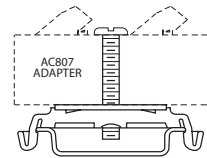

AC807 adapter for EN50022

▼ = **STANDARD OPTIONS**
Specifications subject to change

Loop, powered Indicators



TI196 Head-mounted Indicator



AC102765 Pipe Mounting Hardware Kit



TI350 Indicator

Overview

The display range is field programmable via coarse dip switches and two fine adjustment potentiometers. Wiring is easy. Simply connect the indicator in series with the 4 to 20 mA loop. Forward voltage drop is only 2.8 VDC.

- Local indication of process variable for convenient visual verification
- Enclosures are sealed from harsh environments to enhance product reliability and longevity
- Variety of mounting options allows for flexible and easy installation
- Compatible with 4 to 20 mA temperature transmitters for easy sensor interchangeability
- IP66 NEMA 4X/7 rated (only for TI196)

TI196 head-mounted indicator

The TI196 includes an explosionproof connection head and digital indicator for local indication of temperature. Sensors and transmitters are specified separately. Optional Temptran models TT111, TT211 or TT205 will fit inside the connection head along with the meter.

TI196 Hazardous Area Certification (explosionproof/flameproof):

Class I, Div I, Groups B,C and D
Class II, Div I, Groups E,F and G
Class III
Ex d IIC

TI350 indicator

The TI350 features a washdown compatible digital readout for local indication of temperature. Sensors and transmitters are specified separately. Optional Temptran model TT321 will fit inside the case along with the meter. Other 4 to 20 mA transmitters may be mounted outside the case and used with this device.

- NEMA 4X enclosure
- Cable glands are installed for 0.118" to 0.256" (3mm to 6.5mm) cable

AC102765 pipe mounting hardware kit

Use AC102765 for mounting TI196 or TI350 to vertical or horizontal pipe. Kit includes plate, stainless U-bolts, nuts and washers for 2" schedule 40 pipe [Ø 2.375" (60mm)].

Order model number AC102765

▼ = **STANDARD OPTIONS**

Specifications subject to change



Loop, powered Indicators

TI196 head-mounted indicator

Specifications

Input: 4 to 20 mA DC series connection

Range: User adjustable.
Zero: -500 to +1000 counts.
Span: 10 to 2000 counts.

Accuracy: ± (0.1% reading + 1 count).

Temperature Coefficient:
Zero: ± 0.075 counts/°C typ.
Span: ± 0.005% of span/°C typ.

Linearity: ± (0.1% of span + 1 count).

Forward Voltage Drop: 2.8 volts DC maximum.

Display: 0.59" (15mm) high, 3-1/2 digit LCD, with °C/°F descriptor.

Display Update: 3 times per second.

Underrange Indication: -1 in MSD (Most Significant Digit).

Overrange Indication: 1 in MSD.

Connections: Terminal Block, Pluggable

Decimal: User programmable to 1 position or absent (i.e. 1XX.X or 1XXX).

Ambient Temperature Range:
Operating: 32 to 122°F (0 to 50°C).
Storage: -4 to 149°F (-20 to 65°C).

Weight: 50 oz. (1420 g).

Enclosure: Aluminum, polyester-coated

Enclosure Rating: NEMA 4X, IP66

Dimensions (connection head): 4.5" W x 4.5" H x 3.4" D (144 mm W x 114 mm H x 87 mm D).

TI196 specification and order options

TI196	Model number TI196
P3	Pipe thread size: P2 = 3/4 - 14 NPT (sensor and conduit) P3 = 1/2 - 14 NPT (sensor and conduit)
(0/100)	Temperature range: (4 mA temp./20 mA temp.), user adjustable
C	Display: C = Celsius F = Fahrenheit
TI196P3(0/100)C = Sample part number	

Note: Sensors and transmitters are specified separately.

TI350 indicator

Specifications

Input: 4 to 20 mA DC series connection

Range: User adjustable.
Zero: -500 to +1000 counts.
Span: 10 to 2000 counts.

Accuracy: ± (0.1% reading + 1 count).

Temperature Coefficient:
Zero: ± 0.075 counts/°C typ.
Span: ± 0.005% of span/°C typ.

Linearity: ± (0.1% of span + 1 count).

Forward Voltage Drop: 2.8 volts DC maximum.

Display: 0.59" (15mm) high, 3-1/2 digit LCD, with °C/°F descriptor.

Display Update: 3 times per second.

Underrange Indication: -1 in MSD (Most Significant Digit).

Overrange Indication: 1 in MSD.

Connections: Terminal Block, Pluggable

Decimal: User programmable to 1 position or absent (i.e. 1XX.X or 1XXX).

Ambient Temperature Range:
Operating: 32 to 122°F (0 to 50°C).
Storage: -4 to 149°F (-20 to 65°C).

Weight: 7 oz. (200 g).

Enclosure: Polycarbonate, NEMA 4X.

Dimensions (box only): 2.6" W x 4.5" L x 2.2" D (65 mm W x 115 mm H x 56 mm D).

TI350 specification and order options

TI350	Model number TI350
(0/100)	Temperature range: (4 mA temp./20 mA temp.), user adjustable
C	Display: C = Celsius F = Fahrenheit
TI350(0/100)C = Sample part number	

Note: Sensors and transmitters are specified separately.

▼ = **STANDARD OPTIONS**
Specifications subject to change

CT224 12,Channel Temperature Alarm/Monitor

Overview

The CT224 consists of a 12-Channel temperature monitor/over-temperature alarm and MincoSoft™ CT224 Software. It is the next generation in temperature monitoring equipment from Minco designed to meet the needs of electric machinery protection. The 12-channel scanning capability, standard RS485/RS232 interface and Windows-compatible software utility for system configuration and data logging provide over-temperature and under-temperature protection and critical feedback to safeguard expensive machinery.

- UL and cUL recognized to help meet regulatory compliance
- PC programmable with Windows compatible software makes monitoring easy and efficient, allowing quick reprogramming and extensive data logging
- Mix and match sensor input types for freedom to adapt to pre-installed bearing and apparatus sensors
- Ability to monitor 12 inputs allows you to monitor stator sensors from two motors
- Five outputs, relays or logic offers either internal relay trips or flexibility of external control
- Logic outputs can be used with external SSRs
- Prevent costly damage to motors, generators, transformers, and other equipment
- Power loss protection
- 24 independent trip points (2 per channel)
- Programmable deadband (hysteresis)
- Rugged steel enclosure
- Can be used as a 4-channel on/off controller
- Display High, Low, or Any valid zones
- Self-calibrating

Applications

- Generators
- Motors
- Turbines
- Compressors
- Pumps



Software

MincoSoft™ CT224 software features:

- Compatibility with Microsoft® Windows® operating system
- User-friendly configuration program
- Save unlimited set-up configurations
- Commission mode to test configurations before implementation
- Continuously displayed measurement and relay status of all 12 channels
- Data-logging

▼ = **STANDARD OPTIONS**
Specifications subject to change

CT224 12,Channel Temperature Alarm/Monitor

Specifications

Input: 1 to 12 RTDs (2 or 3-wire), thermocouples, or 4 to 20 mA current loops. Accepts any combination of input types.

Standard Input types:

RTD:

- 200 to 700°C: PA (Platinum / 100 Ω / 0.00392 Ω/Ω/°C)
- 200 to 700°C: PB (Platinum / 100 Ω / 0.00391 Ω/Ω/°C)
- 200 to 850°C: PD/PE (Platinum / 100 Ω / 0.00385 Ω/Ω/°C)
- 200 to 600°C: PF (Platinum / 1000 Ω / 0.00385 Ω/Ω/°C)
- 80 to 260°C: NA (Nickel / 120 Ω / 0.00672 Ω/Ω/°C)
- 100 to 260°C: CA (Copper / 10 Ω / 0.00427 Ω/Ω/°C)

Thermocouple:

- 270 to 1000°C: Type E -270 to 1150°C: Type K
- 200 to 1200°C: Type J -270 to 400°C: Type T

4 to 20 mA current loop: Pressure (PSI, Bar), Humidity (%), Temperature (°F, °C), Vibration (G), and process variable (mA, VDC)
Note: 4 to 20 mA inputs must be linear with respect to the measured variable.

Input scan rate: 1.5 seconds maximum to scan all 12 channels.

Input fault detection: Options for ignoring, sounding alarm, or tripping relays associated with the failed sensor. Other zones are unaffected.

Output: 24 independent trip points (2 per channel): 5 relays, one relay is intended for use as an alarm function (but can be configured as a trip point), and one internal audible alarm. Alarm may be programmed to sound when selected relays trip. Logic output option is available for controlling external SSRs or sending a signal to another device.

Relays: Form C, SPDT 10 A @ 250 VAC/24 VDC resistive load; 10 A make current; 2500 VA breaking capacity, ¼ HP at 120 VAC motor load.

Trip point hysteresis (deadband): Programmable from 0 to 20 (°C or °F).

Display: 20 x 4 line backlit LCD. 0.1°C or 0.1°F resolution. Front panel LEDs indicate relay and alarm status.

Accuracy: 2°C (3°F) in 0 to 60°C (32 to 140°F) ambient, over entire range of the input.

Supply power: 85 to 240 VAC @ 50/60 Hz. or 110 to 250 VDC, 5 watts max.; or 18 to 36 VDC, 6 watts max.

Keyboard: 4 membrane type keys with audible feedback.

Serial interface: RS485 or RS232 (Modbus protocol).

Power loss protection: Trip points and program parameters stored in non-volatile memory. Normal operation resumes when power is restored.

Programming: Programmable from front panel or via RS485 or RS232 interface using Modbus protocol. PC software is included for data logging, commissioning, and configuration. Program settings may be password protected.

Firmware fault protection: Watchdog resets microprocessor if it fails to perform program sequence.

Enclosure: Steel case; NEMA 4 front panel.

Ambient temperature rating: 0 to 60°C (32 to 140°F).

Connections: Terminal blocks at rear accept wires to AWG 12.

Leadwire resistance compensation: Up to 30 Ω per leadwire for RTDs with no effect on reading.

Dimensions: 7.5 x 11.5 x 2" (191 x 292 x 51 mm).

Mounting: Panel mount enclosure. Cutout size of 6.8" x 10.6" (173 x 269 mm).

Weight: 3.8 lbs. (1.72 kg.).

Approvals: UL 508, CSA C22.2 No. 14-M91.

Accessories

AC102734: Communication package. Includes isolated RS232 to RS485 converter and power supply.

Specification and order options

CT224	Model number
A	Power supply A: 85-240 VAC @ 50/60 Hz / 110-250 VDC B: 18-36 VDC
1	Output 1: Relays 2: Logic (5 VDC)
A	Interface A: RS232 B: RS485
CT224A1A = Sample part number	



STOCKED PARTS AVAILABLE

▼ = **STANDARD OPTIONS**
Specifications subject to change

CT424 Temperature Alarm/Monitor

User-programmable three input temperature monitor system

Overview

Minco's CT424 consists of a 3-channel temperature monitor and alarm system that controls three relay outputs based on user-programmable set points to help safeguard expensive machinery.

Features

The CT424 offers users a completely programmable monitor and alarm with improved measurement range and universal inputs. The microprocessor-based design maintains accuracy over a wide range of temperatures and conducts regular self-checks to ensure correct operation. Additionally, one of the relay outputs is specifically designed for control of a cooling fan, and the user-configurable fan exercise option extends the fan life and reduces bearing lock-up. Other key features include:

- Universal inputs of 100 and 1000 $\frac{3}{4}$ platinum RTDs and Types E and K thermocouples
- Configurable through the front-panel interface, MODBUS over USB or the isolated RS-485, PC software included for data logging and configuration
- User-configurable measurement range to Celsius or Fahrenheit scale
- Large, dimmable 7-digit LED display allows easy programming and visibility at various distances and lighting conditions
- Dual password design allows certain users to have full configuration access and others, set points only
- Non-volatile memory storage of per-channel min/max temperatures for recall in the event of power-loss
- Electrically isolated 4-20mA output signal allows for connection to PLCs or remote displays
- UL/cUL recognition (CT424A and CT424B) and CE certification (CT424A)



Applications

Minco's CT424 temperature monitor and alarm is designed with the specifications for dry-type transformer monitoring and protection. Additional applications include use in pumps, compressors and motors.

Specification and order options

CT424	Model number
CT424A	AC power, 120-240VAC 50-60Hz, 120-240VDC
CT424B	DC power: 21-36VDC

▼ = **STANDARD OPTIONS**
Specifications subject to change

CT424 Temperature Alarm/Monitor

Technical Specifications

Performance	Measurement Range	-50°C to 300°C (-58°F to 572°F), 1°C resolution, 2°C full-range accuracy
	Relay Contact Ratings	Voltage: 240V AC Fan Relay: 30A or 1.5HP @ 55°C, derates to 22A or 1.5HP @ 72°C Trip/Alarm Relays: 10A
	Current Loop Outputs <i>Isolated, industry-standard 4-20mA current-loop output for forwarding of reading to PLC or remote indicator.</i>	Configuration: high value, low value, specific channel selection. Scaling: Offset from -50°C to 250°C, span from 50°C to 350°C Error signaling: 3.5mA or 23mA output during sensor failure. Power: isolated loop power –or– non-isolated self-power
	Communications	MODBUS over USB or isolated RS-485, RTU, 300-38400bps
	Certifications	UL/cUL recognized (CT424A and CT424B) and CE certification (CT424A)
Environment	Sensor Inputs <i>Note: "Universal" inputs are standard and are electrically isolated from control logic and communications.</i>	RTD: 100 $\frac{3}{4}$ or 1000 $\frac{3}{4}$ Platinum, 0.00385 $\frac{3}{4}$ / $\frac{3}{4}$ °CTCR, 2- or 3-wire connection, Open and shorted sensor detection Thermocouple: Type K or Type E thermocouple, open detection.
	Temperature Range	-30°C to 72°C (-22°F to 162°F), 95% humidity, non-condensing
	Output Relays	Connection: terminal block, 30 AWG to 10 AWG wire
Mechanical	User Interface	Display: LED, 7-segment, red, 0.56" height, dimmable Indicators: LED, red: Fan, Trip, Alarm, Peak, Manual Fan, Test
	Dimensions	Front-panel: 6.3" x 9.9" Cut-out: 5.67" x 9.17" Depth: 1.9"
	Enclosure	Metal, corrosion-resistant

▼ = STANDARD OPTIONS
Specifications subject to change

CT325 Miniature DC Temperature Controller

Overview

The CT325 Miniature DC Temperature Controller is designed for use with Minco Thermofoil™ heaters and RTD or thermistor sensors. It offers inexpensive on/off temperature control of your process or equipment with accuracy many times better than bimetal thermostats. Easily read and adjust the set point temperature using a voltmeter, then monitor the actual signal temperature at the other end. Operating from your 4.75 to 60 volt DC power supply, the controller can switch up to 4 amps power to the heater. A bright LED indicates when power is applied to the heater.

The entire unit is epoxy filled for moisture resistance, with a through-hole for a mounting bolt. A terminal block provides the power input, sensor input and heater output connections.

- Tight control in a small package means that enclosures or panel spaces are not required which allows successful portable device implementation
- Simple control without complicated programming can reduce set-up time
- Three-wire RTD connection cancels lead resistance for highly accurate temperature readings
- Solid state on-off control with adjustable set point improves durability compared to electro-mechanical devices
- Flexible heating control compliments all Minco Thermofoil™ Heaters for convenient off the shelf operation
- Uses standard 100 ∇ or 1000 ∇ platinum RTD or 50 k ∇ thermistor sensor input
- Single DC power source provides power to the controller and heater up to 240 watts

Applications

- IV solutions for medical/surgical applications
- Military batteries
- Enclosures to maintain the temperature of electronics
- Ruggedized laptop LCDs and hardrives

Custom design options

Minco can customize the design of the CT325 for special applications. Specific temperature ranges, other sensor options, and special packaging are possible for volume OEM applications.



CT325 DC Controller

Specifications

Input: 100 ∇ or 1000 ∇ platinum RTD, 0.00385 $\nabla/\nabla/^{\circ}\text{C}$, 2 or 3-leads, or 50 k ∇ NTC thermistor, 2-lead.

Setpoint range: 2 to 200 $^{\circ}\text{C}$ (36 to 392 $^{\circ}\text{F}$) for platinum RTD input. 25 to 75 $^{\circ}\text{C}$ (77 to 167 $^{\circ}\text{F}$) for thermistor input. Consult factory for other ranges.

Setpoint stability: $\pm 0.02\%$ of span/ $^{\circ}\text{C}$.

V_{temp} signal: 0.010 V/ $^{\circ}\text{C}$ over specified range.

Platinum RTD sensor		Thermistor sensor	
2 $^{\circ}\text{C}$	0.02 V	25 $^{\circ}\text{C}$	0.25 V
50 $^{\circ}\text{C}$	0.50 V	50 $^{\circ}\text{C}$	0.50 V
100 $^{\circ}\text{C}$	1.00 V	75 $^{\circ}\text{C}$	0.75 V
200 $^{\circ}\text{C}$	2.00 V		
Accuracy:	$\pm 1\%$ of span	Accuracy:	$\pm 2\%$ of span
Linearity:	$\pm 0.1\%$ of span	Linearity:	$\pm 2\%$ of span

Deadband: $\pm 0.1^{\circ}\text{C}$ (0.2 $^{\circ}\text{F}$).

Input power: 4.75 to 60 VDC.

Output: Open drain, 4 amps max. DC.

Leadwire compensation: (3-wire RTD) $\pm 0.06^{\circ}\text{C}/\nabla$ for 100 ∇ or 1000 ∇ platinum up to 25 ∇ per leg.

Fault protection: Heater disabled on RTD short or thermistor open. No heater protection; external fuse is recommended.

Operating ambient temperature range: -40 to 70 $^{\circ}\text{C}$ (-40 to 158 $^{\circ}\text{F}$).

Relative humidity: 0 to 95% non-condensing.

Physical: Polycarbonate case, epoxy sealed for moisture resistance.

Weight: 1 oz. (28g).

Connections: Terminal block for wires AWG 22 to AWG 14.

Mounting: Mounting hole for #6 screw through or #8 thread forming screw.

▼ = **STANDARD OPTIONS**
Specifications subject to change

CT325 Miniature DC Temperature Controller

Sensor type	
100 ∇ platinum RTD (0.00385 TCR)	PD
1000 ∇ platinum RTD (0.00385 TCR)	PF
50 k ∇ thermistor R25/R125 = 31.2	TF

Note: 50kW thermistor sensor TS665TF is available on page 9-6

Specification and order options

CT325	Model number
PD	Sensor type from table
1	Power supply: 1 = 4.75 to 10 VDC 2 = 7.5 to 60 VDC
C	Temperature range: A = 25 to 75°C (thermistor only) C = 2 to 200°C (RTD only)
1	Dead band: 1 = 0.1°C
CT325PD1C1 = Sample part number	

Dimensions in inches (mm)

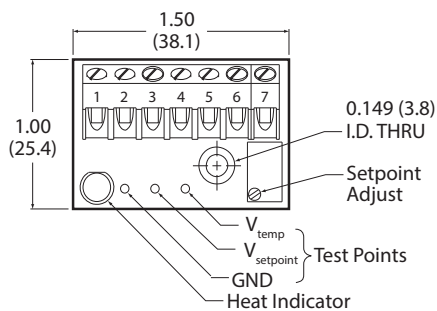
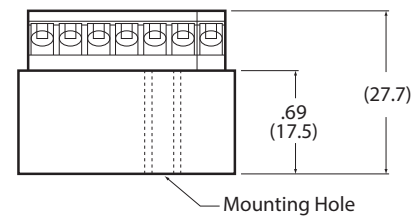

Wiring diagrams

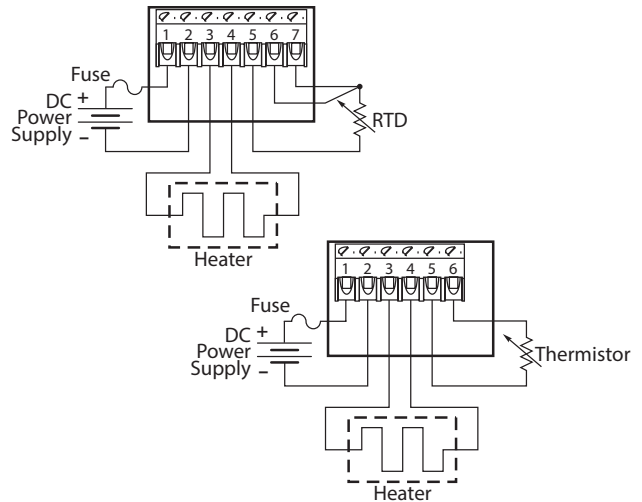

AC powered heaters

The CT325 can provide the control signal to an external solid state relay to switch AC power. Use a DC supply voltage suitable for both the CT325 and SSR.

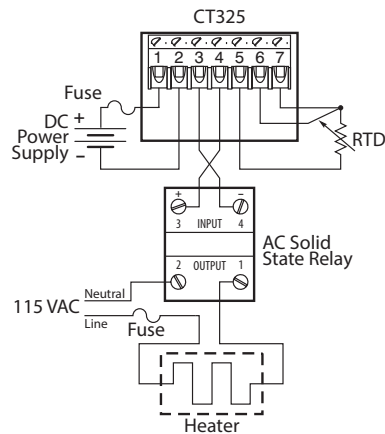

STOCKED PARTS AVAILABLE

▼ = **STANDARD OPTIONS**

Specifications subject to change

CT335 PC Board Mount Temperature Controller

Overview

The CT335 is an OEM micro-processor based temperature controller that offers two sensor inputs, and two outputs. This low cost, PCB mount style proportional controller is great for system integration.

The CT335 multiple output options make it more versatile than other temperature controllers. Option 1) one output capable of handling up to 6 Amps. Option 2) Two open drain outputs with 3 Amps each. Option 3) one open drain output that can handle up to 3 Amps and a logic output option to work with an external SSR for higher power.

- Proportional and On/Off control
- Two inputs and two outputs (solid state)
- Small package designed for PCB mounting
- Able to handle up to 6 Amps
- Operates on 7.5-60 volts DC
- Low cost

Specifications

Sensor Inputs:

100 ∇ at 0°C Pt RTD, 2-leads (0.00385 TCR)

1000 ∇ at 0°C Pt RTD, 2-leads (0.00385 TCR)

Output Options:

One output of 6A

Two outputs of 3A each

One 3A output and one logic output (0-5V)

Controlling Parameters:

Dead-band for On/Off Control: 0.1 to 10°C

Proportional band for Proportional Control: 0.1 to 10°C

Ambient:

Operating temperature: -40 to 70°C (-40 to 158°F)

Storage temperature: -55 to 85°C (-67 to 185°F)

Relative humidity: 90%, non-condensing

Accuracy: $\pm 1^\circ\text{C}$

System stability determined by overall system.

Power supply: 7.5 to 60VDC

Physical: ABS case, epoxy potted for moisture resistance

Case Dimensions: 1.49x1.03x0.36"

Mounting: Pins on 0.1" center for mounting on PCB



AC207473 USB to SPI Converter Kit:

The AC207473 allows the user to configure the CT335 from a PC. It is ideal for prototyping and early-stage development. It consists of a CT335 USB to SPI converter, power supply, USB cable, and software CD for easy user interface.

Operation

The CT335 controller can be configured to On/Off or Proportional control. On/Off control offers faster reaction time and better accuracy over thermostats. The CT335 Proportional control minimizes temperature overshoot and gives steadier temperature control by reducing the time the heater/load stays on as the process temperature approaches the set-point. Note that actual outputs depend on the system's configuration and controlling parameters. See below.

On/Off Control

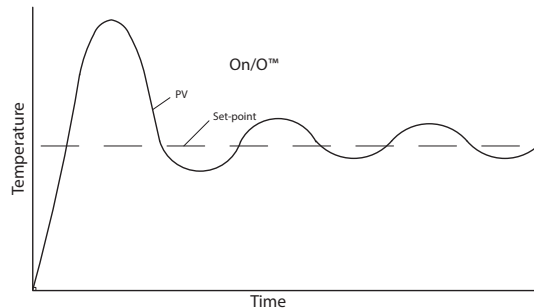

Proportional Control

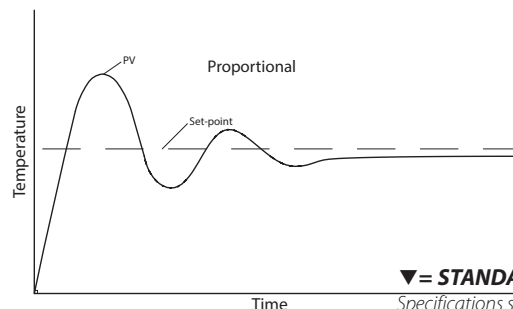

▼ = STANDARD OPTIONS
Specifications subject to change

Specifications subject to change



CT335 PC Board Mount Temperature Controller

Wiring with Different Output Options:

Option 1: One output of 6A

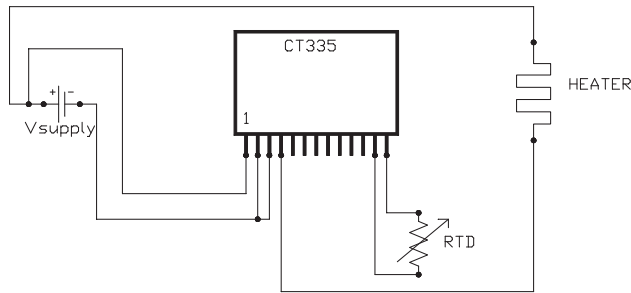

Option 2: Two outputs of 3A each

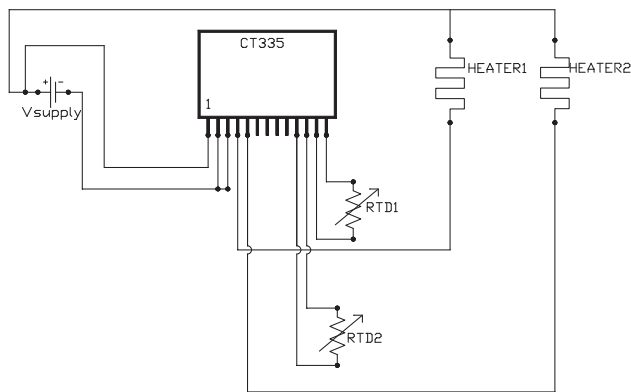

Option 3: One 3A output and one logic output (0-5V)

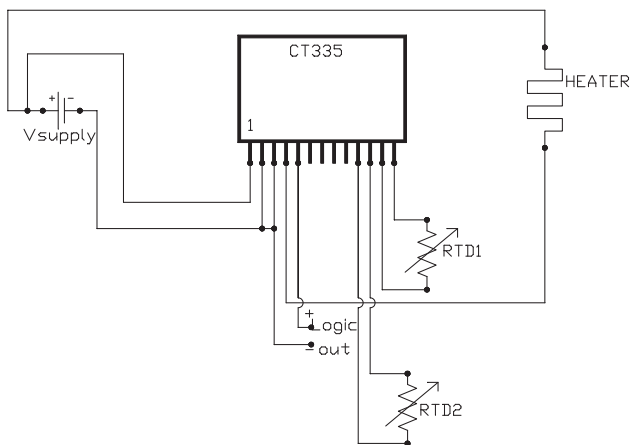

Specifications and order options

CT335	Model Number: CT335
PD	Sensor Types: PD = 100 Ω Platinum RTD (-40 to 200°C) PF = 1000 Ω Platinum RTD
1	Output Options: 1. one output of 6A 2. two outputs of 3A 3. one 3A output and 1 logic output
P	Control Method: O = On/Off P = Proportional
10	Dead-band or Proportional Band 1 = 0.1°C 10 = 1.0°C 100 = 10.0°C
T100	Setpoint Temperature (Min = -40°C, Max = 200°C): XXXX = Setpoint in 0.1°C increments Example: 100 = 10.0°C 103 = 10.3°C -200 = -20.0°C
CT335PD1T100 = Sample part number	

Dimensions

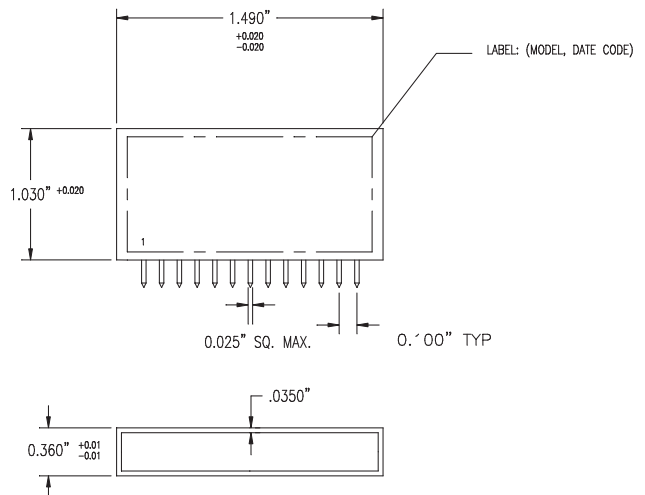

▼ = STANDARD OPTIONS
Specifications subject to change

CT435 PC Board Mount Temperature Controller

Programmable Multi-input/output Controller

Overview

The CT435 is an OEM micro-processor based PID temperature controller that offers two independent sensor inputs and two outputs. This low cost, PCB mount style PID controller is very flexible through its many configuration options. Using the UART Modbus interface, system parameters, sensor temperatures, and output status may be read and/or written, allowing for complete system integration with existing micro-processors.

- Two RTD temperature sensor inputs – Pt100 or Pt1000
- Wide temperature sensing range
- All controller features are configurable through the UART Modbus interface
- Two independent solid state open drain outputs – 3A each
- Each output individually configurable for any variation of PID, On/Off, or Alarm control
- Auto-tune feature estimates PID coefficients for several control types
- 32-bit microprocessor executes both PID loops simultaneously at individually configurable rates up to 25 times/second
- Addressable Modbus protocol allows for multiple units connected on one set of UART lines
- No additional heat sinking required
- Small package designed for PCB mounting
- Operates from a 5V supply
- Low cost

Specifications

Sensor Inputs:

100 ∇ at 0°C Pt RTD, 2-leads (0.00385 TCR)
 1000 ∇ at 0°C Pt RTD, 2-leads (0.00385 TCR)
 2-wire connection
 Open and shorted sensor detection

Measurement Range:

-70°C to 650°C (-94°C to 1202°F), 0.25°C full-range accuracy at 25°C ambient

Accuracy:

25°C ambient: $\pm 0.25^\circ\text{C}$ or $\pm 0.25\%$ of range
 Full range ambient: $\pm 1.5^\circ\text{C}$ or $\pm 1\%$ of range
 System stability determined by overall system.



Electrical:

Input power: 5 to 24VDC, 20mA typical, 40mA max

Outputs: 2 open drain outputs, 60V max switching voltage

Number of Outputs in Use	Controller Supply Voltage	Ambient Temperature	Current Rating
1 Output	5-12 VDC	25°C	7 A
		70°C	4 A
	12-24 VDC	25°C	6 A
		70°C	3 A
2 Outputs	5-12 VDC	25°C	5 A
		70°C	3 A
	12-24 VDC	25°C	5 A
		70°C	2.5 A

Environmental:

Operating temperature: -40 to 70°C (-40 to 158°F)

Storage temperature: -55 to 85°C (-67 to 185°F)

Relative humidity: 90%, non-condensing

Communication:

Modbus over UART – 19.2kbps, no flow control

Package:

Enclosure: ABS case, epoxy potted

Dimensions: 1.49x1.03x0.36"

Mounting: Pins on 0.1" center for mounting on PCB

∇ = STANDARD OPTIONS

Specifications subject to change

CT435 PC Board Mount Temperature Controller

Operation:

The CT435 controller can be configured to PID (and any variation) or On/Off control. On/Off control offers faster reaction time and better accuracy over thermostats. PID control minimizes temperature overshoot and gives steadier temperature control by utilizing proportional, integral, and derivative control factors. The inputs and outputs may be configured in any fashion, and all parameters are read/write through the addressable UART Modbus interface. The controller and heaters may be powered from the same supply or separate supplies, as long as they share a common ground.

How to Order:

CT435	Model number
PD	Sensor Types: PD = 100 ∇ Platinum RTD PF = 1000 ∇ Platinum RTD
CT435PD = Sample part number	

Common Wiring Diagram:

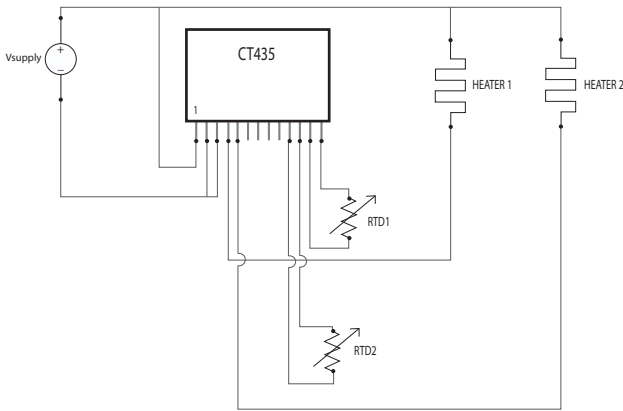

Dimensions:

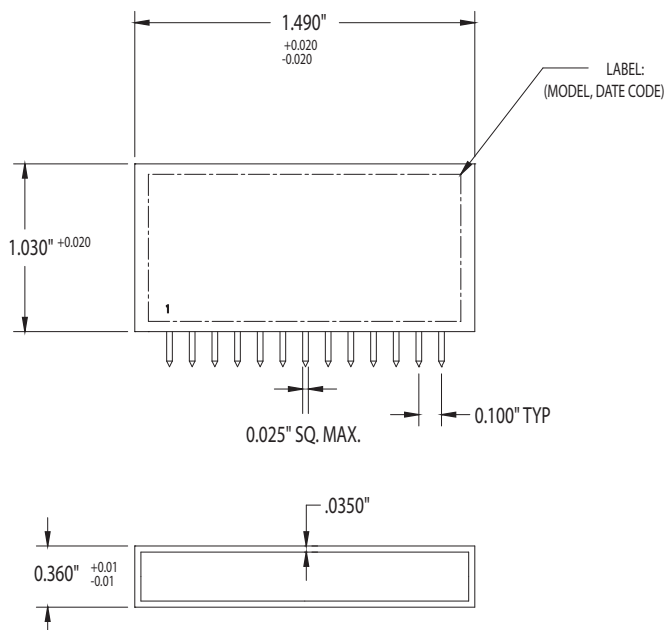

▼ = STANDARD OPTIONS
Specifications subject to change

CT15 Temperature Controller & Alarm



CT15 Controller

Overview

The CT15 is an easy-to-use controller with sophisticated PID control. It can also be a single or 2-stage alarm (using alarm feature plus control relay) to monitor motors and generators for overheating.

- RTD or thermocouple input
- Control modes: Self-Tune, pre-set or programmable PID, or On/Off
- Bright red LED display
- Ramp to setpoint
- Digital sensor input correction
- Digital input filter adjustable for noisy or jittery processes
- Four security levels
- Setpoint limits
- Non-volatile memory needs no battery backup
- Input fault timer
- Alarms at one or two temperatures
- Alarm Relay option is programmable for high, low, absolute, or deviation, can be reset manually or automatically, and controls a single electromechanical relay with voltage-free contacts

Specifications

Selectable inputs:

RTD: 2 or 3-wire, Minco types PD or PE (100 ∇ EN60751 platinum).
Thermocouple: Type J (factory default), K, T (selectable).

Input impedance:

Thermocouple: 3 megohms minimum.
RTD current: 200 μ A maximum.

Sensor break or short protection: De-energizes control outputs to protect system.

Loop break protection: Error message is initiated and output is turned off in case of shorted sensor or open heater circuit. Break time adjustable from OFF to 99 minutes.

Cycle rate: 1 to 80 seconds.

Setpoint range: Selectable from -212 to 1371°C (-350 to 2500°F), input dependent.

Display: One 4 digit, 7 segment, 0.3" high LED. Display shows the measured temperature unless a control key is pressed, then it will display the item value.

Control action: Reverse (usually heating) or Direct (usually cooling), selectable.

Ramp/Soak: One ramp, 0 to 100 hours.

∇ = STANDARD OPTIONS
Specifications subject to change

CT15 Temperature Controller & Alarm

Specifications continued

Accuracy: $\pm 0.25\%$ of span ± 1 count.

Resolution: 1° or 0.1° , selectable.

Line voltage stability: $\pm 0.05\%$ over supply voltage range.

Temperature stability: $4 \text{ } \#V/^\circ\text{C}$ ($2.3 \text{ } \#V/^\circ\text{F}$) typical, $8 \text{ } \#V/^\circ\text{C}$ ($4.5 \text{ } \#V/^\circ\text{F}$) max. ($100 \text{ ppm}/^\circ\text{C}$ typical, $200 \text{ ppm}/^\circ\text{C}$ max.).

Isolation: Relay and SSR outputs are isolated. Pulsed voltage output must not share a common ground with the input.

Supply voltage: 100 to 240 VAC nom., $+10/-15\%$, 50 to 400 Hz, single phase; 132 to 240 VDC, nom., $+10/-20\%$. 5 VA maximum.

Note: Do not confuse controller power with heater power. The controller does not supply power to the heater, but only acts as a switch. For example, the controller could be powered by 115 VAC, but controlling 12 VDC to the heater.

Operating temperature range: -10 to 55°C (14 to 131°F).

Memory backup: Non-volatile memory (no batteries required).

Control output ratings:

AC SSR (SPST): 3.5 A @ 250 VAC @ 25°C (77°F); derates to 1.25 A @ 55°C (131°F).

Minimum 48 VAC and 100mA required.

An SSR is recommended for longer life than a mechanical relay.

Switched voltage (non-isolated):

5 VDC @ 25 mA.

Mechanical relay, SPST Form A (Normally Open):

3 A resistive, 1.5 A inductive @ 250 VAC;
pilot duty: 250 VA; 2 A @ 125 VAC or
1 A @ 250 VAC.

Alarm relay, SPST Form A (Normally Open):

3 A resistive, 1.5 A inductive @ 250 VAC;
pilot duty: 250 VA; 2 A @ 125 VAC or
1 A @ 250 VAC.

Weight: 227g (8 oz.).

Agency approvals: UL & CSA.

Front panel rating: Type 4X (IP66).

Specification and order options

CT15	Model number
1	Alarm: 0 = No 1 = Yes
2	Input: 1 = J, K, or T thermocouple 2 = 100 ∇ platinum RTD, type PD or PE
1	Output: 1 = Built-in AC SSR 2 = Pulsed voltage (5 VDC) 3 = Mechanical relay
CT15121 = Sample part number	

Note: See page 4-37 for controller accessories.

Dimensions shown in inches (mm)

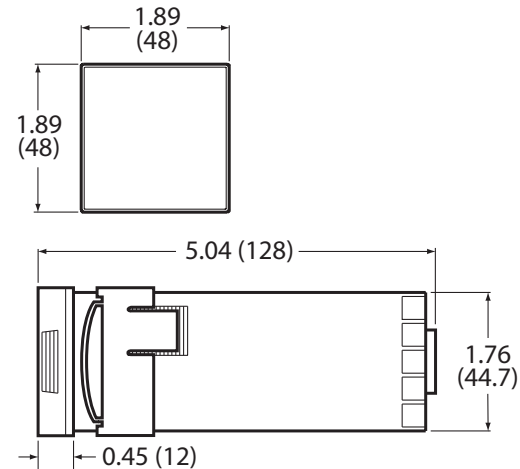

PANEL CUTOUT: 1.775" \times 1.775" (45 mm \times 45 mm)

MAXIMUM PANEL THICKNESS: 0.25" (6.35 mm)

DIMENSIONS IN INCHES (mm)



STOCKED PARTS AVAILABLE

Specifications subject to change

CT16A Temperature Controller



CT16A Controller

Overview

This economical controller packs sophisticated PID control into a compact 1/16 DIN enclosure. A wide range of control modes, sensor input types, and relay or SSR outputs give versatile control of Thermofoil™ heaters and lets you easily connect to other electronics.

- Dual displays continuously show the set point and the actual temperature reading in resolutions of 1°, 0.1°, or engineering units
- Universal Input fits any sensor: Select from 10 thermocouple types, 4 RTD types, voltage, and current signals
- Isolated Outputs for safe, easy wiring
- Loop Break protection handles sensor or heater failure
- Peak / Valley records the maximum and minimum temperatures
- Front panel is waterproof and corrosion-resistant, making it ideal for sanitary applications. Illuminated keypad for easy operation
- Limit the temperatures which the operator can set via four password-protected Security Levels
- Controller can Self-Tune for best PID control
- Control modes: Self-Tune, pre-set or adjustable PID values, simple On/Off control, and open loop
- Fuzzy Logic provides better response time and reduces overshoot in processes with unpredictable inputs
- Alarms at one or two temperatures
- Alarm Relay option is programmable for high, low, absolute, or deviation, can be reset manually or automatically, and controls a single electromechanical relay with voltage-free contacts

- Ramp & Soak option handles complex heating profiles of 16 segments with front-panel activation and a selectable time base (CT16A3)
- Auto / Manual option easily switches to manual control for set up or experiments (CT16A3)
- RS-232 or RS-485 Serial Communications access the temperature readings and all control parameters (optional)
- Retransmit either the sensed temperature or the set point as a voltage or current signal to a computer or recorder (optional)
- 4-Stage Set Point to quickly switch from one temperature to the next (optional)

Specifications

Selectable inputs:

RTD: 2 or 3-wire, Minco types

PD or PE (100 ∇ EN60751 platinum),

PA (100 ∇ NIST platinum),

PF (1000 ∇ EN60751 platinum), or

NA (120 ∇ Nickel).

Thermocouple: Type J (factory default), K, T, L, E, R, S, B, C, or N.

DC current: 0-20 mA or 4-20 mA (use with Temptran™ transmitters).

DC voltage: 0-10 or 2-10 VDC, -10 to 10 mVDC, scalable.

Input impedance:

Voltage: 5000 ∇.

Thermocouple: 3 megohms minimum.

Current: 10 ∇.

RTD current: 200 #A.

∇ = **STANDARD OPTIONS**

Specifications subject to change

CT16A Temperature Controller

Specifications continued

Sensor break or short protection:

Selectable output: disabled, average output before fault, or preprogrammed output.
Adjustable delay: 0.0 to 540.0 minutes.

Loop break protection: Error message is initiated and output is turned off in case of shorted sensor or open heater circuit.
Break time adjustable from OFF to 9999 seconds.

Cycle rate: 1 to 80 seconds.

Setpoint range: Selectable from -212 to 2320°C (-350 to 4208°F), input dependent.

Displays: Two, 4 digit, 7 segment, 0.3" high LEDs. Process Value red, Setpoint Value green. °C or °F.

Control action: Reverse (usually heating) or Direct (usually cooling), selectable.

Ramp/soak: (CT16A3 only) 16 separate ramp and soak times are adjustable in minutes or seconds from 0 to 9999. When the program has ended, you may choose to repeat, hold, revert to local setpoint, or turn the outputs off.

Accuracy: ±0.25% of span ±1 count.

Resolution: 1° or 0.1°, selectable.

Line voltage stability: ±0.05% over supply voltage range.

Temperature stability: 4 #V/°C (2.3 #V/°F) typical, 8 #V/°C (4.5 #V/°F) max. (100 ppm/°C typical, 200 ppm/°C max.).

Isolation:

Relay and SSR: 1500 VAC to all other inputs and outputs.
SP1 and SP2 current and voltage: 500 VAC to all other inputs and outputs, but not isolated from each other.
Process output (options 934, 936): 500 VAC to all other inputs and outputs.

Supply voltage: 100 to 240 VAC nom., +10/-15%, 50 to 400 Hz, single phase; 132 to 240 VDC, nom., +10/-20%. 5 VA maximum.

Note: Do not confuse controller power with heater power. The controller does not supply power to the heater, but only acts as a switch. For example, the controller could be powered by 115 VAC, but controlling 12 VDC to the heater.

Operating temperature range:

-10 to 55°C (14 to 131°F).

Memory backup: Non-volatile memory (no batteries required).

Control output ratings:

AC SSR (SPST): 2.0 A combined outputs

A & B @ 240 VAC @ 25°C (77°F);
derates to 1.0 A @ 55°C (131°F).

An SSR is recommended for longer life than a mechanical relay.

Mechanical relay, SPST Form A (Normally Open) or Form B (Normally Closed):

3 A resistive, 1.5 A inductive @ 240 VAC;

pilot duty: 240 VA; 2 A @ 120 VAC or 1 A @ 240 VAC.

Switched voltage (isolated): 15 VDC @ 20 mA.

Current (isolated): 0 to 20 mA, 600 ∇ max.

DC SSR: 1.75 A @ 32 VDC max.

Alarm relay, SPST Form A (Normally Open):

3 A @ 240 VAC resistive;

1/10 HP @ 120 VAC.

Specifications and order options

CT16A	Model number
2	Feature set: 2 = Standard 3 = Enhanced (ramp & soak, Auto/manual)
1	Alarm relay: 0 = No 1 = Yes
1	Output A: 1 = Built-in AC SSR 2 = Pulsed voltage (15 VDC) for external SSR 3 = Mechanical relay, SPST (normally open) 4 = Mechanical relay, SPST (normally closed) 5 = Current 8 = DC SSR
0	Output B: 0 = None 1 = Built-in AC SSR 2 = Pulsed voltage (15 VDC) for external SSR 3 = Mechanical relay, SPST (normally open) 4 = Mechanical relay, SPST (normally closed) 5 = Current
-948	Options on next page (leave blank for none)
CT16A2110-948 = Sample part number	

See page 4-37 for Accessories.

▼ = STANDARD OPTIONS

Specifications subject to change

CT16A , Options and Accessories

Dimensions shown in inches (mm)

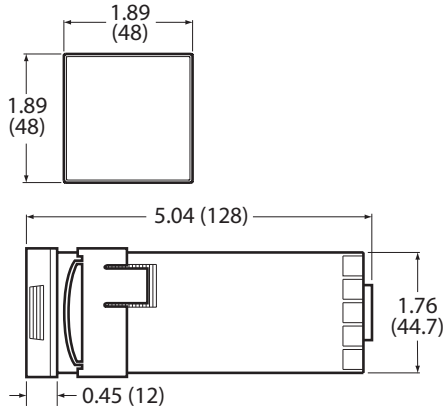

PANEL CUTOUT: 1.775" x 1.775" (45 mm x 45 mm)
 MAXIMUM PANEL THICKNESS: 0.25" (6.35 mm)

Additional options for CT16A (board level)

934: Analog retransmission of Process Variable or Set Variable: (4 to 20 mA DC) For use as recorder, transmitter or computer A/D input. Linearized 4 to 20 mA DC signal follows the Process or Set variable. Scalable.

936: Analog retransmission of Process Variable or Set Variable: (0 to 10 VDC) Similar to option 934, but output signal is linearized 0 to 10 VDC.

948: 4-Stage setpoint: Four preset setpoints may be selected by external contacts. Each set point has its own set of PID values giving controller 4 distinct "recipes" for different process situations.

992: RS-485 Computer communication link: Allows remote computer to read and write all control parameters.

993: RS-232 Computer communication link: Allows remote computer to read and write all control parameters.

Accessories for CT15 and CT16A

AC744: 1-10 A, 24 to 280 VAC SSR

AC745: 1-25 A, 24 to 280 VAC SSR

AC746: 1-50 A, 24 to 280 VAC SSR

AC1009: 1-20 A, 0 to 100 VDC SSR

AC743: SSR heat sink for high current or ambient temperature

AC996 R/C Snubber: Highly recommended to prolong relay contact life if using the mechanical relay or SSR output to drive a relay or solenoid. Also, for the CT16A AC SSR output, make sure that the coil HOLDING current is greater than 100 mA and voltage is minimum 48 VDC.

AC1001: Steel 1/16 to ¼ DIN adapter plate. 127 x 127 mm gray steel with 45 x 45 mm centered hole.



▼ = **STANDARD OPTIONS**
 Specifications subject to change

CT425 Temperature Controller

Versatile, configurable controller with Bluetooth option

Overview

Minco's CT425 Temperature Controller provides simple, yet quick customization for most controller applications. The CT425 Temperature Controller features three user-configurable outputs, two programmable inputs, and communication via USB.

Minco's CT425 Temperature Controller is a PID temperature controller capable of reading two independent temperature sensors (RTDs). By utilizing an internal solid state relay, logic voltage output, and internal mechanical relay, the controller is fully configurable. Simply connect the CT425 to a laptop or PC to configure.

Features

Flexible configuration for:

Inputs:

- Utilize one or two Platinum RTDs
- Choose 100 or 1000 ohm RTDs (independently programmable)

Outputs:

- Utilize up to three outputs
 - Solid state relay
 - Logic voltage
 - Mechanical relay
- Choose control type
 - PID
 - On/Off (mechanical relay only)
 - Alarm
- USB and a user-friendly software package allow for easy setup and use
- 32-bit microprocessor executes both PID loops simultaneously at individually configurable rates up to 25 times/second
- High current capacity internal switching
- Electrically isolated switching outputs increase high voltage safety
- AC powered models perform zero-cross detection to reduce switching noise
- LED indicators provide a quick confirmation of correct sensors input operation



Applications

The CT425 is designed for a variety of applications that include heating and cooling of equipment or processes. The CT425's versatility makes it ideal to use as an off-the-shelf prototyping tool or as an economical controller for small to medium volume applications. Moreover, the CT425's modular design provides the platform for fast and cost-effective custom designs for medium to high volume applications.

Bluetooth option

The controller may be ordered with Bluetooth communication (Bluetooth Low Energy, Class 2). The Bluetooth may be used to view real-time data and make basic setting changes.

▼ = **STANDARD OPTIONS**
Specifications subject to change

CT425 Temperature Controller

Specifications

CT425 Temperature Controller					
Performance	Measurement Range	-70°C to 650°C (-94°C to 1202°F), 0.25°C full-range accuracy at 25°C			
	Input Power	Model CT425A: 120VAC, 50-60Hz Model CT425B: 10.5-60VDC Model CT425C: 240VAC, 50-60Hz			
	Sensor Inputs (RTD)	100 ³ / ₄ or 1000 ³ / ₄ Platinum, 0.00385 ³ / ₄ / ³ / ₄ /°CCTCR, 2-wire connection, Open and shorted sensor detection			
	Connections	5mm spacing terminal block			
Environment	Output Ratings	Output	Max Voltage	Current (25C)	Current (55C)
		120VAC Solid State (CT425A)	120VAC	6A	5A
		DC Solid State (CT425B)	60VDC	15A	11A
		240VAC Solid State (CT425C)	240VAC	3A	2.5A
		Mechanical Relay	250VAC/30VDC	10A resistive	
	Logic Voltage	4.4V, +/- 0.1V output	26mA, +/- 3mA		
Temperature Range	-20°C to 55°C, 90% humidity, non-condensing				
Mechanical	Dimensions	5.46" x 3.34" x 1.22"			
	Weight	350 grams (12.3 ounces)			
	Enclosure	UL 94V-0 ABS plastic with epoxy potting			

Ordering Information

To configure your temperature controller, select from the options listed below to determine the complete part number.

CT425	Power Supply
CT425A	120VAC power, 120 VAC solid state relay
CT425B	10.5–60VDC power, DC solid state relay
CT425C	240VAC power, 240 VAC solid state relay
Additional Option: -BT Blank for none	Bluetooth Communication
CT425A, CT425A-BT = Sample part number	

▼ = **STANDARD OPTIONS**
Specifications subject to change

