

# Humidity Sensor/Transmitter Assembly



## Overview

Minco humidity and humidity/temperature transmitters are designed using an advanced microprocessor. Digital signal processing allows these transmitters to precisely match the characteristics of the humidity sensor to a wide range of RH and temperature values found in the many applications the product serves.

The humidity sensor is composed of an integrated circuit (IC) with a stable polymer element and platinum RTD that is used for temperature compensation. This sensor offers outstanding resistance to airborne contaminant and chemicals, and is protected by a sintered stainless steel filter which resists condensation.

- Wall/Duct/OSA mounting configurations
- Accuracies of  $\pm 1\%$  or  $\pm 2\%$  RH
- Temperature compensated
- Temperature output option
- Two-point field calibration
- NIST traceable calibrations

## Applications

Building environmental control systems (HVAC), hospitals, food storage, warehouses, clean rooms, pharmaceutical, freezers, drying equipment, and emissions monitoring.

## Specifications

### Ambient Temperature:

Operating:

Room:  $-10$  to  $150^{\circ}\text{F}$  ( $-23$  to  $65^{\circ}\text{C}$ ), non-condensing.

Wall/Duct/OSA:  $-10$  to  $185^{\circ}\text{F}$  ( $-23$  to  $85^{\circ}\text{C}$ ), non-condensing.

Storage:

Room:  $-58$  to  $150^{\circ}\text{F}$  ( $-50$  to  $65^{\circ}\text{C}$ ), non-condensing.

Wall/Duct/OSA:  $-58$  to  $185^{\circ}\text{F}$  ( $-50$  to  $85^{\circ}\text{C}$ ), non-condensing.

**Supply voltage:** 9.5 to 35 VDC, non-polarized.

**Voltage effect:**  $\pm 0.001\%$  of span/volt from 9.5 to 35 VDC.

**Loop resistance:** The maximum allowable resistance of the signal-carrying loop, including extension wires and load resistors, is given by this formula:  $R_{\text{loopmax}} = (V_{\text{supply}} - 9.5)/0.02$  AMPS. For example, if supply voltage is 24 VDC, the loop resistance must be less than  $725 \Omega$ .

**Adjustments:** Zero and span field adjustments, non-interacting.

**Time Constant:** 50 seconds in slow moving air.

**Connections:** Screw terminals (22-14 AWG wire).

### Weight:

Room: 0.19 lb (.084 kg).

Wall/Duct/OSA: 1.20 lb (0.55 kg).

**Minimum output current:** 3.5 mA

**Maximum output current:** 23 mA.

▼ = **STANDARD OPTIONS**  
Specifications subject to change

# Humidity Sensor/Transmitter Assembly

## Humidity Transmitter AH429 and AH439

**Output:** 4-20 mA DC = 0% to 100% RH.

**Sensing Element:** Capacitive monolithic IC.

**Accuracy:** Includes temperature, linearity, hysteresis, and repeatability.

- ±1% from 10% to 80% RH @ 25 to 35°C or
- ±2% from 0% to 90% RH @ 25°C
- (±3% from 0% to 90% RH @ 15 to 50°C)
- (±5% from 0% to 90% RH @ 0 to 82°C)

## Temperature Transmitter (AH439 only)

**Output:** 4-20 mA DC over the specified temperature range.

**Sensing element:** 1000 Ω platinum; 2 lead resistance thermometer, 0.00385 TCR.

**Accuracy:** Includes resistance thermometer tolerance, calibration accuracy, linearity, and ambient temperature effects.

- ±.75% of Temptran™ span for 32 to 122°F ambient.
- ±1.50% of Temptran™ span for -13 to 185°F ambient.

## AH429 Specification and order options

|  |   |
|--|---|
| ▼AH429   | Model number:   |
| R  | Enclosure<br>▼D: Duct mount, 8" probe length<br>▼O: Outside Air/Wall mount, 4" probe length with shield, weather resistant enclosure<br>▼S: Space mount<br>▼W: Wall mount, 4" probe length, weather resistant enclosure<br>R: Remote probe, 4" probe length |
| 1  | Output: 4 to 20 mA DC   |
| N10  | Calibration accuracy (humidity transmitter)<br>▼N10: ±1% from 10% to 80% (25 to 35°C) with NIST certificate<br>N20: ±2% from 0% to 90% (25 to 35°C) with NIST certificate<br>▼S20: ±2% from 0% to 90% (25 to 35°C)  |
| T1   | Sensing element cover<br>(omitted on "S" space mount models)<br>T0= Sintered stainless steel; pressed on cover<br>▼T1= Sintered stainless steel; screw on cover<br>T2= Slotted stainless steel; screw on cover<br>(NA on "O" outside air models)            |
| To order enclosure D, O, S or W, stop here.<br>To order enclosure R (remote probe), add: |   |
| A  | Probe mounting location<br>A = Side mounting    B = Bottom mounting   |
| 48   | Remote probe cable length (in inches)<br>48" and 96" are standard lengths   |
| AH429R1N10T1A48 = Sample part number   |   |

## AH429 = Humidity Transmitter

## AH439 = Humidity/Temperature Transmitter

## AH439 Specification and order options

|  |   |
|--|---|
| ▼AH439   | Model number:   |
| D  | Enclosure<br>▼D: Duct mount, 8" probe length<br>▼O: Outside Air/Wall mount, 4" probe length with shield, weather resistant enclosure<br>▼S: Space mount<br>W: Wall mount, 4" probe length, weather resistant enclosure<br>R: Remote probe, 4" probe length                              |
| 1  | Outputs: 4 to 20 mA DC  |
| N10  | Calibration accuracy (humidity transmitter)<br>▼N10: ±1% from 10% to 80% (25 to 35°C) with NIST certificate<br>N20: ±2% from 0% to 90% (25 to 35°C) with NIST certificate<br>▼S20: ±2% from 0% to 90% (25 to 35°C)  |
| A  | Temperature transmitter range<br>▼EN: -20°F to 140°F<br>S: 0°F to 100°F<br>▼A: 20°F to 120°F<br>B: 30°F to 130°F<br>KK: 30°F to 180°F<br>▼N: 32°F to 122°F<br>H: 40°F to 90°F<br>More temperature range codes starting on page 4-20 or <a href="http://www.minco.com">www.minco.com</a> |
| T1   | Sensing element cover<br>(omitted on "S" space mount models)<br>T0= Sintered stainless steel; pressed on cover<br>▼T1= Sintered stainless steel; screw on cover<br>T2= Slotted stainless steel; screw on cover<br>(NA on "O" outside air models)  |
| To order enclosure D, O, S or W, stop here.<br>To order enclosure R (remote probe), add: |   |
| A  | Probe mounting location<br>A = Side mounting    B = Bottom mounting   |
| 48   | Remote probe cable length (in inches)<br>48" and 96" are standard lengths   |
| AH439D1N10AT1A48 = Sample part number  |   |

▼ = STANDARD OPTIONS  
 Specifications subject to change



# Hazardous Area Humidity Assembly



## Overview

Models AH71\_, AH72\_, and AH73\_ series are 2-wire temperature compensated humidity transmitters that are FM and CFM approved for use in hazardous locations. Intrinsically safe models are available with an optional temperature transmitter output. The AH73 is also available with an optional digital display for remote indication of relative humidity and temperature.

The transmitters utilize a thin film capacitive humidity sensor which provides outstanding sensitivity and chemical robustness. The transmitter converts the humidity sensor's signal into a 4 to 20 mA DC current, which changes proportionally from 4 mA at 0% RH to 20 mA at 100% RH. The optional temperature loop produces a second 4 to 20 mA DC output where the current changes from 4 mA at the lowest temperature of the range, to 20 mA at the top of the temperature range. The leads that supply power also carry the current signal.

- Accuracy of  $\pm 2.5\%$  RH
- Temperature compensated
- Temperature output option
- Two-point field calibration
- NIST traceable calibrations

## Applications

Building automation systems (HVAC), hospitals, food storage, warehouses, clean rooms, pharmaceutical, drying equipment, and emissions monitoring.

## Specifications

### Output(s):

Humidity: 4 to 20 mA DC = 0% to 100% RH.  
Temperature: 4 to 20 mA DC over specified range (optional)

**Humidity Range:** 0 – 100% RH

### Sensing Element:

Humidity: Thin film capacitive element.  
Temperature: 1000 ohm platinum RTD, 0.00385 TCR

**Temperature Effect:**  $\pm 0.03\%$  RH/ $^{\circ}\text{C}$   $\pm 1\%$  from  $10^{\circ}\text{C}$  to  $85^{\circ}\text{C}$

### Operating Temperature:

Transmitter:

- 40 to 176°F (-40 to  $80^{\circ}\text{C}$ ), non-condensing.
- 4 to 176°F (-20 to  $80^{\circ}\text{C}$ ), non-condensing, model AH73.

Sensor:

- 40 to 302°F (-40 to  $150^{\circ}\text{C}$ ).

### Storage Temperature:

-58 to 185°F (-50 to  $85^{\circ}\text{C}$ ), non-condensing.

### Supply voltage:

9.5 to 28 VDC for intrinsically safe (IS) models.  
16.5 to 28 VDC for explosionproof (XP) models.

**Voltage effect:**  $\pm 0.001\%$  of span/volt from 9.5 to 28 VDC.

**Loop resistance:** The maximum allowable resistance of the signal-carrying loop, including extension wires and load resistors, is given by this formula:

IS:  $R_{\text{loopmax}} = (V_{\text{supply}} - 9.5)/0.02 \text{ AMPS}$ . For example, if supply voltage is 24 VDC, the loop resistance must be less than 725  $\Omega$ .

XP:  $R_{\text{loopmax}} = (V_{\text{supply}} - 16.5)/0.02 \text{ AMPS}$ . For example, if supply voltage is 24 VDC, the loop resistance must be less than 375  $\Omega$ .

▼= **STANDARD OPTIONS**  
Specifications subject to change

# Hazardous Area Humidity Assembly

**Accuracy:** Includes linearity, hysteresis, repeatability, and voltage effects.  
 Humidity:  $\pm 2.5\%$  from 10% to 80% RH @ 25°C,  $\pm 3.5\%$  from 80% to 90% RH @ 25°C.  
 Temperature:  $\pm 0.5^\circ\text{F}$  ( $0.27^\circ\text{C}$ ) @ 77°F (25°C) or  $\pm 0.75\%$  of span, whichever is greater.

**Adjustments:** Zero and Span field adjustments, non-interacting.

**Time Constant:** 50 seconds in slow moving air.

**Connections:** Screw terminals (22-14 AWG wire).

**Weight:**

AH71\_ 2.84 lbs (1.29 kg).  
 AH72\_, AH73\_ 4.46 lbs (2.02 kg).

**Min. output current:** 3.8 mA.

**Max. output current:** 22 mA.

**Filter:** 60 micron stainless-steel sintered filter (replacement P/N : AC103512)

**Factory Mutual Approvals:**

Explosionproof with intrinsically safe sensor:  
 Suitable for the following hazardous area locations:  
 Class I, Division 1, 2, Groups B, C, D  
 Class II, Division 1, 2, Groups E, F, G  
 Class III, Division 1, 2

Intrinsically safe installation:  
 Suitable for the following hazardous area locations:  
 Class I, Division 1, 2, Groups A, B, C, D  
 Class II, Division 1, 2, Groups E, F, G  
 Class III, Division 1, 2  
 Class I, Zone 0, AEx ia IIC T4

Non-Incendive:  
 Suitable for the following hazardous area locations:  
 Class I, Division 2, Groups A, B, C, D  
 Class II, Division 2, Groups F, G  
 Class III, Division 2

**Transmitter entity parameters:**

$V_{max} = 28$  volts;  $I_{max} = 100$  mA;  $C_i = 0.037$   $\mu\text{F}$  and  $L_i = 0$  mH.

**Transmitter ranges:**

| Code | Transmitter range          |
|------|----------------------------|
| ▼NT  | No temperature transmitter |
| ▼EN  | -20°F to 140°F             |
| S    | 0°F to 100°F               |
| ▼A   | 20°F to 120°F              |
| BI   | 30°F to 130°F              |
| KK   | 30°F to 180°F              |
| ▼N   | 32°F to 122°F              |
| H    | 40°F to 90°F               |

**Accessories:**

Sintered Filter Replacement Part Number: AC103512  
 Slotted Filter Replacement Part Number: AC103513  
 Pipe Mounting Kit for AH72/AH73 Part Number: AC102765  
 Wall Mounting Kit for AH71 Part Number: AC103168  
 Duct Mounting Kit for AH71 Part Number: AC103253

**Specification and order options**

|  |   |                |                |
|--|---|----------------|----------------|
| AH73   | <b>Model number</b><br>▼ AH71 Industrial grade humidity transmitter with optional temperature transmitter, CH106 connection head, display NA<br>AH72 Industrial grade humidity transmitter with optional temperature transmitter, connection head, display NA<br>▼ AH73 Industrial grade humidity transmitter with optional temperature transmitter, connection head, display available |                |                |
| 1  | <b>Probe diameter</b><br>▼ 1 = 0.375"   |                |                |
| P3   | <b>Pipe Thread Code</b>   | <b>Process</b> | <b>Conduit</b> |
|  | ▼ P3  | 1/2 - 14NPT    | 1/2 - 14NPT    |
|  | P4  | 1/2 - 14NPT    | 3/4 - 14NPT    |
|  | P5  | G1/2A          | 1/2 - 14NPT    |
|  | P6  | G1/2A          | 3/4 - 14NPT    |
| L120   | <b>Probe length</b><br>▼ L60 = 6"<br>▼ L120 = 12"   |                |                |
| T1   | <b>Filter type</b><br>▼ T1 = Sintered stainless steel<br>T2 = Slotted stainless steel   |                |                |
| HT490  | <b>Transmitter model number</b><br>▼ HT480 = Explosionproof with intrinsically safe sensor (transmitter code NT only)<br>▼ HT490 = Intrinsically safe   |                |                |
| F  | <b>Display</b><br>C = Display, metric units (AH73_series only)<br>▼ F = Display, English units (AH73_series only)<br>▼ N = No display (AH71_ and AH72_ series only)   |                |                |
| 1  | <b>Signal output</b><br>▼ 1 = 4 to 20mA   |                |                |
| N25  | <b>Calibration accuracy</b> (humidity transmitter)<br>▼ N25 $\pm 2.5\%$ from 10% to 80% (25°C) with NIST certificate<br>S25: $\pm 2.5\%$ from 10% to 80% (25°C)   |                |                |
| EN   | <b>Temperature transmitter range from table</b>   |                |                |
| AH731P3L120T1HT490F1N25EN = Sample part number |   |                |                |

▼ = STANDARD OPTIONS  
 Specifications subject to change



# Intrinsically Safe Humidity Assembly



## Overview

Models AH74 and AH75 are 2-wire temperature compensated humidity transmitters that are FM and CFM approved as intrinsically safe for use in hazardous locations. Both models are available with an optional temperature transmitter output. AH75 incorporates a digital display for remote indication of relative humidity and temperature.

The transmitters utilize a thin film capacitive humidity sensor which provides outstanding sensitivity and chemical robustness. The transmitter converts the humidity sensor's signal into a 4 to 20 mA DC current, which changes proportionally from 4 mA at 0% RH to 20 mA at 100% RH. The optional temperature loop produces a second 4 to 20 mA DC output where the current changes from 4 mA at the lowest temperature of the range, to 20 mA at the top of the temperature range. The leads that supply power also carry the current signal.

- Accuracy of  $\pm 2.5\%$  RH
- Temperature compensated
- Temperature output option
- Two-point field calibration
- NIST traceable calibrations

## Applications

Building automation systems (HVAC), hospitals, food storage, warehouses, clean rooms, pharmaceutical, drying equipment, and emissions monitoring.

## Specifications

### Output(s):

Humidity: 4 to 20 mA DC = 0% to 100% RH.

Temperature: 4 to 20 mA DC over specified range (optional).

**Humidity Range:** 0 – 100% RH

### Sensing Element:

Humidity: Thin film capacitive element.

Temperature: 1000 ohm platinum RTD.

**Temperature Effect:**  $\pm 0.03\%$  RH/ $^{\circ}\text{C}$   $\pm 1\%$  from 10 $^{\circ}\text{C}$  to 85 $^{\circ}\text{C}$

### Operating Temperature:

Transmitter:

-40 to 176 $^{\circ}\text{F}$  (-40 to 80 $^{\circ}\text{C}$ ), non-condensing.

-4 to 176 $^{\circ}\text{F}$  (-20 to 80 $^{\circ}\text{C}$ ), non-condensing, model AH75.

Sensor:

-40 to 176 $^{\circ}\text{F}$  (-40 to 80 $^{\circ}\text{C}$ ),

### Storage Temperature:

-58 to 185 $^{\circ}\text{F}$  (-50 to 85 $^{\circ}\text{C}$ ), non-condensing.

**Supply voltage:** 9.5 to 28 VDC .

**Voltage effect:**  $\pm 0.001\%$  of span/volt from 9.5 to 28 VDC.

**Loop resistance:** The maximum allowable resistance of the signal-carrying loop, including extension wires and load resistors, is given by this formula:  $R_{\text{loopmax}} = (V_{\text{supply}} - 9.5)/0.02 \text{ AMPS}$ .

**Accuracy:** Includes linearity, hysteresis, repeatability, and voltage effects.

Humidity:  $\pm 2.5\%$  from 10% to 80% RH @ 25 $^{\circ}\text{C}$ ,  $\pm 3.5\%$  from 80% to 90% RH @ 25 $^{\circ}\text{C}$ .

Temperature:  $\pm 0.5^{\circ}\text{F}(0.27^{\circ}\text{C})$  @ 77 $^{\circ}\text{F}$  (25 $^{\circ}\text{C}$ ) or  $\pm 0.75\%$  of span, whichever is greater.

**Adjustments:** Zero and Span field adjustments, non-interacting.

**Time Constant:** 50 seconds in slow moving air.

**Connections:** Screw terminals (22-14 AWG wire).

### Weight:

AH74 0.54 lbs (245 g).

AH75 0.61 lbs (276 g).

**Min. output current:** 3.8 mA.

**Max. output current:** 22 mA.

**Filter:** 60 micron stainless-steel sintered filter (replacement P/N : AC103512)

### Factory Mutual Approvals:

Intrinsically safe:

Suitable for the following hazardous area locations:

Class I, Division 1, Groups A, B, C, D

Class I, Zone 0, AEx ia IIC T4

Non-Incendive:

Suitable for the following hazardous area locations:

Class I, Division 2, Groups A, B, C, D

### Transmitter entity parameters:

$V_{\text{max}} = 28 \text{ volts}$ ;  $I_{\text{max}} = 100 \text{ mA}$ ;  $C_i = 0.037 \mu\text{F}$  and  $L_i = 0 \text{ mH}$ .

▼ = STANDARD OPTIONS  
Specifications subject to change

# Intrinsically Safe Humidity Assembly

## Transmitter ranges:

| Code | Transmitter range          |
|------|----------------------------|
| ▼NT  | No temperature transmitter |
| EN   | -20°F to 140°F             |
| S    | 0°F to 100°F               |
| ▼A   | 20°F to 120°F              |
| BI   | 30°F to 130°F              |
| KK   | 30°F to 180°F              |
| N    | 32°F to 122°F              |
| H    | 40°F to 90°F               |

## Specification and order options

|   |   |
|---|---|
| AH75  | <b>Model Number:</b><br>▼AH74 - Humidity Transmitter with Optional Temperature Transmitter, No Display<br>▼AH75 - Humidity Transmitter with Optional Temperature Transmitter, with Display  |
| 1   | <b>Probe Diameter:</b> 1 = 0.375"   |
| C3  | <b>Probe Location / Cable Bushings Option:</b><br>Please refer to dimensional drawings for probe Location.<br>C1 = Probe Location A (Rear) / Single Cable Gland<br>C2 = Probe Location A (Rear) / Dual Cable Glands<br>▼C3 = Probe Location A (Rear) / Single Conduit Fitting, 1/2" NPT<br>▼C4 = Probe Location A (Rear) / Dual Conduit Fittings, 1/2" NPT<br>▼C5 = Probe Location B (Bottom) / Single Cable Gland<br>▼C6 = Probe Location B (Bottom) / Dual Cable Glands<br>▼C7 = Probe Location B (Bottom) / Single Conduit Fitting, 1/2" NPT<br>▼C8 = Probe Location B (Bottom) / Dual Conduit Fittings, 1/2" NPT<br><i>Note: If a temperature loop is desired, dual cable glands or dual conduit fittings must be selected unless special cable is used during installation. Please refer to National Electrical Code ANSI/NFPA 70 for installation in accordance with US requirements, or Canadian Electrical Code, C22.1 for installation in accordance with Canadian requirements.</i> |
| L40   | <b>Probe Length:</b> ▼L40 = 4"  |
| T1  | <b>Filter Type:</b><br>▼ T1 = Sintered Stainless Steel<br>T2 = Slotted Stainless Steel  |
| HT490   | <b>Transmitter Model Number:</b><br>▼ HT490 = Intrinsically Safe Transmitter  |
| F   | <b>Display:</b><br>C = Display, Metric Units (AH75_ Series Only)<br>▼ F = Display, English Units (AH75_ Series Only)<br>▼ N = No Display  |
| 1   | <b>Signal Output:</b> ▼1 = 4-20mA   |
| N25   | <b>Calibration Accuracy:</b><br>▼ N25 = ±2.5% from 10% to 80% (25°C) with NIST Certificate<br>S25 = ±2.5% from 10% to 80% (25°C)  |
| NT  | <b>Temperature Transmitter Range from table:</b> ▼A, NT   |
| AH751C3L40T1HT490F1N25NT = Sample part number |   |

## Dimensions:

### Probe Location A

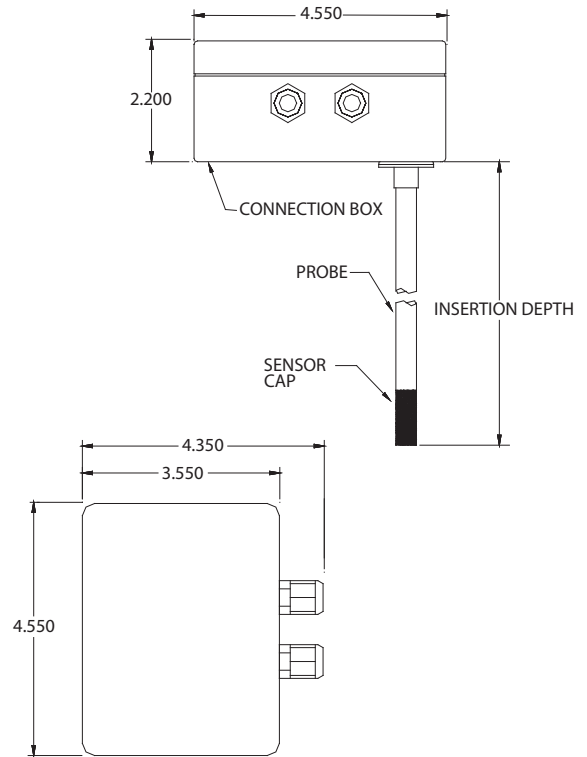

### Probe Location B

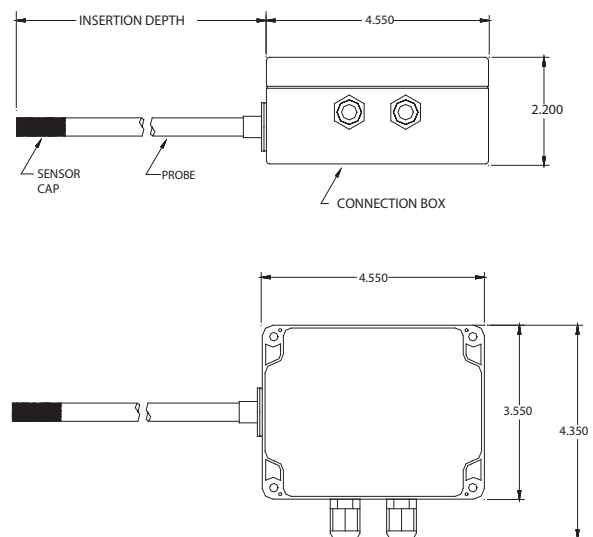

▼ = STANDARD OPTIONS  
 Specifications subject to change