



► SECTION 1: ASSEMBLIES

- Easy-to-order temperature sensor assemblies to fit a variety of applications
- RTDs, thermocouples, and transmitters
- Fittings, connection heads, and thermowells included
- Tip-sensitive, high temperature, explosionproof, and flameproof options

Section 1: Temperature Sensor Assemblies

Tip-sensitive spring loaded	1-2 to 1-3
Tip-sensitive direct immersion.....	1-4 to 1-5
Tip-sensitive with thermowells.....	1-6 to 1-7
High temp. with thermowells.....	1-8 to 1-9
Hazardous area sensor assemblies.....	1-10 to 1-15
Eurostyle.....	1-16 to 1-17
Specifying custom assemblies.....	1-18

Tip/sensitive Spring/loaded RTDs

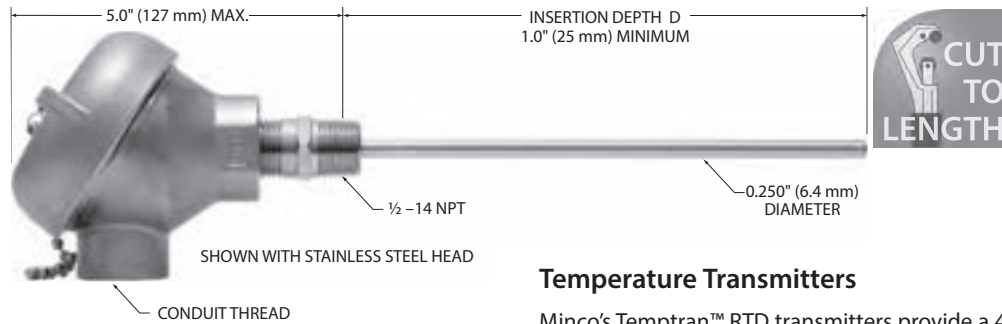

Overview

Fast and accurate readings from bearings, blocks, and other solids. Minco's spring-loaded holder ensures solid contact in drilled holes and has a built-in oil seal. The sensing probe features a copper alloy tip for quick response to temperature changes.

- Tip-sensitive RTD probe for use to 260°C (500°F)
- Spring-loaded holder with fluid seal
- Cast iron, stainless steel, or aluminum connection head

Specifications

Temperature range: -50 to 260°C (-58 to 500°F).

Material:

Probe: Stainless steel with copper alloy tip.

Holder: Stainless steel with Viton O-ring.

Connection head: Cast iron, aluminum, or stainless steel.

Pressure rating: 50 psi (3.4 bar).

Insulation resistance: 100 megohms minimum at 100 VDC, leads to case.

Connection: Terminal block for wires to AWG 14.

Time constant: Typical value in moving water:

Single element: 1.5 seconds.

Dual element: 3.0 seconds.

Sensing Elements

Element		Code
Platinum (0.00392 TCR)	100 Ω ±0.5% at 0°C	▼PA
Platinum (0.00385 TCR) (Meets EN60751, Class B)	100 Ω ±0.1% at 0°C	▼PD
Platinum (0.00385 TCR)	100 Ω ±0.5% at 0°C	PE
Copper (0.00427 TCR)	10 Ω ±0.2% at 25°C	CA
(dual)	10 Ω ±0.5% at 25°C	CC
Nickel (0.00672 TCR)	120 Ω ±0.5% at 0°C	NA

Temperature Transmitters

Minco's Temptran™ RTD transmitters provide a 4 to 20 mA signal or HART® Protocol that can be sent over long distances with a simple 2-wire system. See Section 4 for complete temperature transmitter specifications.

Special high-accuracy calibration: For high system accuracy specify transmitters with matched calibration. Calibration data traceable to NIST will also be provided. Get more information on page 4-22.

Specification and order options

AS5004	Assembly number ▼ AS5004: Single element RTD ▼ AS5005: Dual element RTD
PA	Sensing element from table
60	Insertion depth D: Specify in 0.1" increments (Ex: 60 = 6.0 inches) ▼ :15, 20, 30, 40, 50, 60, 70, 80, 90, 100, 110, 120, 140, 160, 180, 200, 240, 300, 360
Z	Leads per sensing element: Y = 2 leads ▼ Z = 3 leads (required for CA and CC elements) X = 4 leads (PD elements only)
1	Conduit thread: ▼ 1 = 1/2 - 14 NPT 2 = 3/4 - 14 NPT
A	Connection head: C = Cast iron ▼ A = Aluminum S = Stainless steel
To order sensor assembly, stop here.	
To order with transmitters (single platinum element only) add:	
211	Temptran™ transmitter model: 211 = TT211: Fixed Range (2-lead RTDs) 508 = TT508: Programmable (2 & 3-lead RTDs) 511 = TT511: HART® Programmable (2, 3, & 4-lead RTDs)
A	Temperature range codes starting on page 4-20 or at www.minco.com
1	Calibration: 1 = Nominal calibration 2 = Match calibrated, 0.75% total system accuracy. For other calibration options, contact Minco
AS5004PA60Z1A211A1 = Sample part number	

▼ = STANDARD OPTIONS

Specifications subject to change

Tip/sensitive Spring/loaded Thermocouples

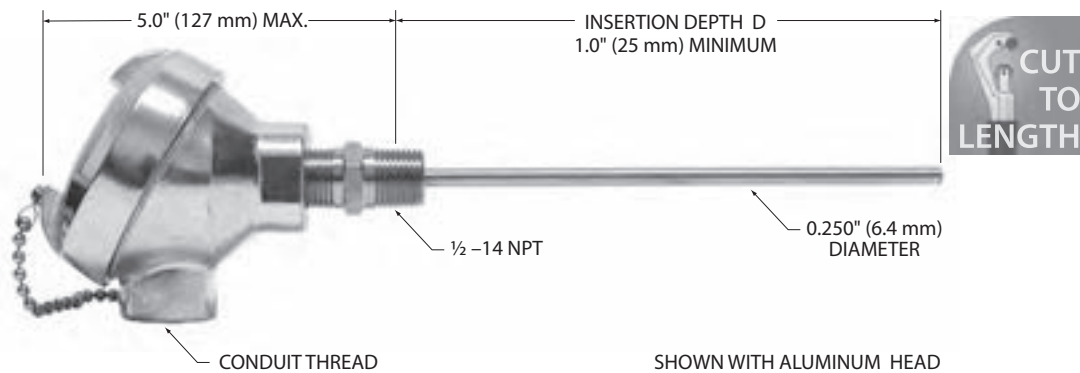

Overview

Fast and accurate readings from bearings, blocks, and other solids. Minco's spring-loaded holder ensures solid contact in drilled holes and has a built-in oil seal. The sensing probe features a copper alloy tip for quick response to temperature changes.

- Tip-sensitive Thermocouple for use to 260°C 500°F)
- Spring-loaded holder with fluid seal
- Cast iron, stainless steel, or aluminum connection head

Specifications

Temperature range: -50 to 260°C (-58 to 500°F).

Material:

Probe: Stainless steel with copper alloy tip.
 Holder: Stainless steel with Viton O-ring.
 Connection head: Cast iron, aluminum, or stainless steel.

Pressure rating: 50 psi (3.4 bar).

Insulation resistance: 10 megohms minimum at 100 VDC, leads to case. Ungrounded junctions only.

Connection: Terminal block for wires to AWG 14.

Time constant: Typical value in moving water:

Grounded junction: 1.5 seconds.
 Ungrounded junction: 7 seconds

Temperature Transmitters

Minco's Temptran™ thermocouple transmitters provide a 4 to 20 mA signal or HART® Protocol that can be sent over long distances with a simple 2-wire system. See Section 4 for complete temperature transmitter specifications.

Specification and order options

AS5192	Assembly number ▼ AS5191: Single junction ▼ AS5192: Dual junction
E	Junction type: ▼ E = Chromel-Constantan J = Iron-Constantan ▼ K = Chromel-Alumel T = Copper-Constantan
U	Junction grounding: G = Grounded ▼ U = Ungrounded
120	Insertion depth D: Specify in 0.1" increments (Ex: 120 = 12.0 inches) ▼: 20, 30, 40, 50, 60, 70, 80, 90, 100, 110, 120
P	
1	Conduit thread: ▼ 1 = 1/2 - 14 NPT ▼ 2 = 3/4 - 14 NPT
A	Connection head: C = Cast iron ▼ A = Aluminum S = Stainless steel
To order sensor assembly, stop here.	
To order with transmitter, add:	
509	Temptran™ transmitter model: 205 = TT205: Fixed Range, Miniature 509 = TT509: Programmable, Hockey Puck 511 = TT511: HART® Programmable, Hockey Puck
A	Temperature range codes starting on page 4-20 or at www.minco.com
AS5192EU120P1A509A = Sample part number	

▼ = **STANDARD OPTIONS**
 Specifications subject to change

Tip/sensitive Direct Immersion RTDs

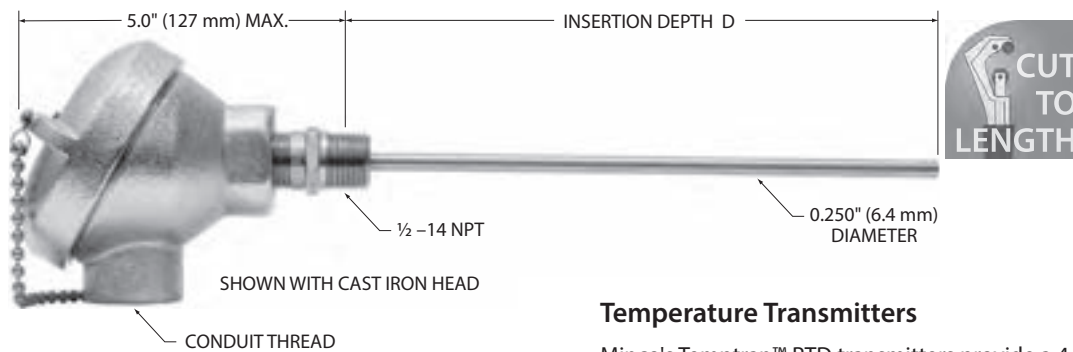

Overview

Mount sensors directly in fluid flow for fast response. Probes are rated to 100 psi (6.9 bar). For use in non-corrosive fluids only.

- RTD probe for use to 260°C 500°F)
- Adjustable fluid seal fitting
- Cast iron, stainless steel, or aluminum connection head

Specifications

Temperature range: -50 to 260°C (-58 to 500°F).

Material:

Probe: Stainless steel with copper alloy tip.
 Fitting: Stainless steel, silicone rubber O-ring.
 Connection head: Cast iron, aluminum, or stainless steel.

Pressure rating: 100 psi (6.9 bar).

Insulation resistance: 100 megohms minimum at 100 VDC, leads to case.

Connection: Terminal block for wires to AWG 14.

Time constant: Typical value in moving water:
 Single element: 2.0 seconds.
 Dual element: 5.0 seconds.

Sensing elements

Element		Code
Platinum (0.00392 TCR)	100 Ω ±0.5% at 0°C	PA
Platinum (0.00385 TCR) (Meets EN60751, Class B)	100 Ω ±0.1% at 0°C	▼PD
Platinum (0.00385 TCR)	100 Ω ±0.5% at 0°C	PE
Copper (0.00427 TCR)	10 Ω ±0.2% at 25°C	CA
(dual)	10 Ω ±0.5% at 25°C	CC
Nickel (0.00672 TCR)	120 Ω ±0.5% at 0°C	NA

Temperature Transmitters

Minco's Tempran™ RTD transmitters provide a 4 to 20 mA signal or HART® Protocol that can be sent over long distances with a simple 2-wire system. See Section 4 for complete temperature transmitter specifications.

Special high-accuracy calibration: For high system accuracy specify transmitters with matched calibration. Calibration data traceable to NIST will also be provided. Get more information on page 4-22.

Specification and order options

AS5200	Assembly number ▼AS5200: Single element ▼AS5201: Dual element
PD	Sensing element from table
100	Insertion depth D: Specify in 0.1" increments (Ex: 100 = 10.0 inches) ▼:15, 20, 30, 40, 50, 60, 70, 80, 90, 100, 110, 120, 140, 160, 180, 200, 240, 300, 360
Z	Leads per sensing element: Y = 2 leads ▼Z = 3 leads (required for CA and CC elements) X = 4 leads (PD elements only)
1	Conduit thread: ▼1 = 1/2 - 14 NPT 2 = 3/4 - 14 NPT
A	Connection head: C = Cast iron ▼A = Aluminum S = Stainless steel
To order sensor assembly, stop here. To order with transmitters (single platinum element only) add:	
508	Tempran™ transmitter model: 211 = TT211: Fixed Range (2-lead RTDs) 508 = TT508: Programmable (2 & 3-lead RTDs) 511 = TT511: HART® Programmable (2, 3, & 4-lead RTDs)
A	Temperature range codes starting on page 4-20 or at www.minco.com
1	Calibration: 1 = Nominal calibration 2 = Match calibrated, 0.75% total system accuracy. For other calibration options, contact Minco
AS5200PD100Z1A508A1 = Sample part number	

▼ = STANDARD OPTIONS
 Specifications subject to change

Tip/sensitive Direct Immersion Thermocouples

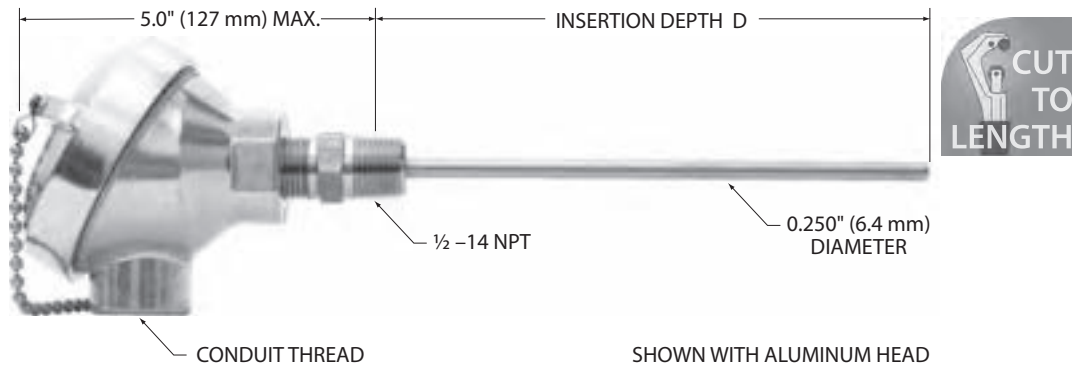

Overview

Mount sensors directly in fluid flow for fast response. Probes are rated to 100 psi (6.9 bar). For use in non-corrosive fluids only.

- Thermocouple for use to 260°C 500°F)
- Adjustable fluid seal fitting
- Cast iron, stainless steel, or aluminum connection head

Specifications

Temperature range: -50 to 260°C (-58 to 500°F).

Material:

Probe: Stainless steel with copper alloy tip.
 Fitting: Stainless steel, silicone rubber O-ring.
 Connection head: Cast iron, aluminum, or stainless steel.

Pressure rating: 100 psi (6.9 bar).

Insulation resistance: 10 megohms minimum at 100 VDC, leads to case. Ungrounded junctions only.

Connection: Terminal block for wires to AWG 14.

Time constant: Typical value in moving water:

Grounded junction: 1.5 seconds.
 Ungrounded junction: 7 seconds.

Temperature Transmitters

Minco's Temptran™ thermocouple transmitters provide a 4 to 20 mA signal or HART® Protocol that can be sent over long distances with a simple 2-wire system. See Section 4 for complete temperature transmitter specifications.

Specification and order options

AS5205	Assembly number AS5205: Single junction AS5206: Dual junction
E	Junction type: E = Chromel-Constantan J = Iron-Constantan K = Chromel-Alumel T = Copper-Constantan
U	Junction grounding: G = Grounded U = Ungrounded
215	Insertion depth D: Specify in 0.1" increments (Ex: 215 = 21.5 inches)
P	
1	Conduit thread: 1 = 1/2 - 14 NPT 2 = 3/4 - 14 NPT
C	Connection head: C = Cast iron A = Aluminum S = Stainless steel
To order sensor assembly, stop here.	
To order with transmitter, add:	
509	Temptran™ transmitter model: 205 = TT205: Fixed Range, Miniature 509 = TT509: Programmable, Hockey Puck 511 = TT511: HART® Programmable, Hockey Puck
A	Temperature range codes starting on page 4-20 or at www.minco.com
AS5205EU215P1C509A = Sample part number	

▼ = **STANDARD OPTIONS**
 Specifications subject to change

Tip/sensitive RTDs with Thermowells

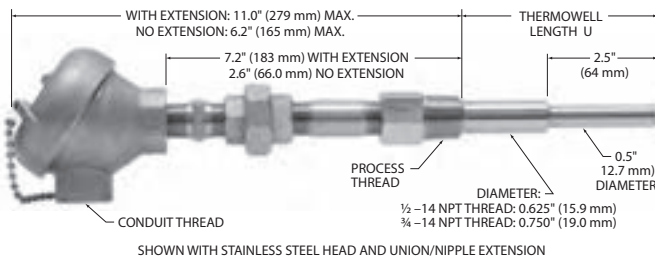

Overview

Thermowells protect sensors from the effects of fluid flow and pressure. These assemblies are spring-loaded for positive probe contact against the bottom of the thermowell. The probe's copper alloy tip provides superior time response and reduces error from stem conduction.

- 316 stainless steel thermowell
- Tip-sensitive RTD probe for use to 260°C (500°F)
- Spring-loaded probe
- Cast iron, stainless steel, or aluminum connection head

Specifications

Temperature range: -50 to 260°C (-58 to 500°F).

Material:

Probe: Stainless steel with copper alloy tip.
 Connection head: Cast iron, aluminum, or stainless steel.
 Thermowell: 316 stainless steel.
 Extension: Stainless steel.

Pressure rating: 7000 psi (483 bar) at 21°C, reducing to 6300 psi (433 bar) at 260°C.

Standard U dimensions: 2.5, 4.5, 6.0, 7.5, 8.0, 10.5, 13.5, 16.5, and 22.5".

Insulation resistance: 100 megohms minimum at 100 VDC, leads to case.

Connection: Terminal block for wires to AWG 14.

Time constant: 17 seconds typical in moving water.

Sensing elements

Element		Code
Platinum (0.00392 TCR)	100 Ω ±0.5% at 0°C	PA
Platinum (0.00385 TCR) (Meets EN60751, Class B)	100 Ω ±0.1% at 0°C	▼PD
Platinum (0.00385 TCR)	100 Ω ±0.5% at 0°C	PE
Copper (0.00427 TCR)	10 Ω ±0.2% at 25°C	CA
(dual)	10 Ω ±0.5% at 25°C	CC
Nickel (0.00672 TCR)	120 Ω ±0.5% at 0°C	NA

Temperature Transmitters

Minco's Tempran™ RTD transmitters provide a 4 to 20 mA signal or HART® Protocol that can be sent over long distances with a simple 2-wire system. See Section 4 for complete temperature transmitter specifications.

Special high-accuracy calibration: For high system accuracy specify transmitters with matched calibration. Calibration data traceable to NIST will also be provided. Get more information on page 4-22.

Specification and order options

AS5140	Assembly number ▼AS5140: Single element RTD ▼AS5141: Dual element RTD
CA	Sensing element from table
60	Thermowell length U: Specify in 0.1" increments (Ex: 60 = 6.0 inches) ▼:15, 20, 25, 30, 40, 45, 60, 75, 90, 100, 105, 120, 150
Z	Leads per sensing element: Y = 2 leads ▼Z = 3 leads (required for CA and CC elements) X = 4 leads (PD elements only)
1	Conduit thread: ▼1 = 1/2 - 14 NPT 2 = 3/4 - 14 NPT
A	Connection head: C = Cast iron ▼A = Aluminum S = Stainless steel
1	Thermowell process thread: ▼1 = 1/2 - 14 NPT 2 = 3/4 - 14 NPT
U	Extension option: P = Coupling/nipple extension ▼N = No extension ▼U = Union/Nipple extension
To order sensor assembly, stop here. To order with transmitters (single platinum element only) add:	
508	Tempran™ transmitter model: 211 = TT211: Fixed Range (2-lead RTDs) 508 = TT508: Programmable (2 & 3-lead RTDs) 511 = TT511: HART® Programmable (2, 3, & 4-lead RTDs)
A	Temperature range codes starting on page 4-20 or at www.minco.com
1	Calibration: 1 = Nominal calibration 2 = Match calibrated, 0.75% total system accuracy. For other calibration options, contact Minco
AS5140CA60Z21A1U508A1 = Sample part number	

▼ = STANDARD OPTIONS
 Specifications subject to change

Tip/sensitive Thermocouples with Thermowells

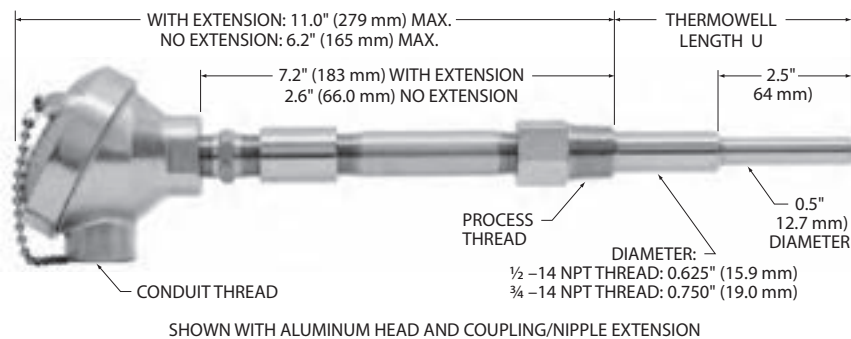

Overview

Thermowells protect sensors from the effects of fluid flow and pressure. These assemblies are spring-loaded for positive probe contact against the bottom of the thermowell. The probe's copper alloy tip provides superior time response and reduces error from stem conduction.

- 316 stainless steel thermowell
- Tip-sensitive thermocouple for use to 260°C 500°F)
- Spring-loaded probe
- Cast iron, stainless steel, or aluminum connection head

Specifications

Temperature range: -50 to 260°C (-58 to 500°F).

Material:

Probe: Stainless steel with copper alloy tip.

Connection head: Cast iron, aluminum, or stainless steel.

Thermowell: 316 stainless steel.

Extension: Stainless steel.

Pressure rating: 7000 psi (483 bar) at 21°C, reducing to 6300 psi (433 bar) at 260°C.

Standard U dimensions: 2.5, 4.5, 6.0, 7.5, 8.0, 10.5, 13.5, 16.5, and 22.5".

Insulation resistance: 10 megohms min. at 100 VDC, leads to case. Ungrounded junctions only.

Connection: Terminal block for wires to AWG 14.

Time constant: Typical value in moving water.

Grounded junction: 17 seconds.

Ungrounded junction: 22 seconds.

Temperature Transmitters

Minco's Temptran™ thermocouple transmitters provide a 4 to 20 mA signal or HART® Protocol that can be sent over long distances with a simple 2-wire system. See Section 4 for complete temperature transmitter specifications.

Specification and order options

AS5145	Assembly number AS5145: Single junction TC AS5146: Dual junction TC
E	Junction type: E = Chromel-Constantan J = Iron-Constantan K = Chromel-Alumel T = Copper-Constantan
U	Junction Grounding: G = Grounded U = Ungrounded
135	Thermowell length U: Specify in 0.1" increments (Ex: 135 = 13.5 inches)
P	
1	Conduit thread: 1 = 1/2 - 14 NPT 2 = 3/4 - 14 NPT
C	Connection head: C = Cast iron A = Aluminum S = Stainless steel
1	Thermowell process thread: 1 = 1/2 - 14 NPT 2 = 3/4 - 14 NPT
U	Extension option: P = Coupling/nipple extension N = No extension U = Union/Nipple extension
To order sensor assembly, stop here.	
To order with transmitter, add:	
509	Temptran™ transmitter model: 205 = TT205: Fixed Range, Miniature 509 = TT509: Programmable, Hockey Puck 511 = TT511: HART® Programmable, Hockey Puck
A	Temperature range codes starting on page 4-20 or at www.minco.com
AS5145EU135P1C1U509A = Sample part number	

▼ = **STANDARD OPTIONS**

Specifications subject to change



550°C RTDs with Thermowells

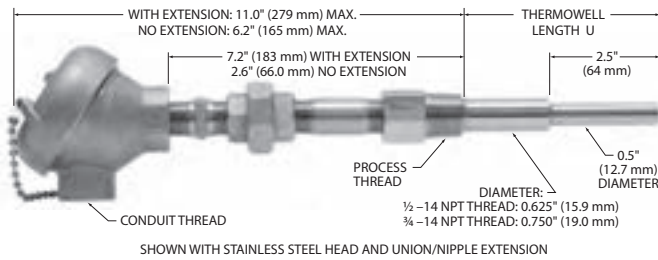

Overview

Sense temperature in high-pressure fluids and gases. These assemblies are spring-loaded for positive probe contact against the bottom of the thermowell.

- 316 stainless steel thermowell
- RTD probe for use to 550°C (1022°F)
- Spring-loaded probe
- Cast iron, stainless steel, or aluminum connection head

Note: For temperatures less than 260°C (500°F), assemblies using tip-sensitive sensors are recommended.

Specifications

Temperature range:

Thermowell and sensor: -100 to 550°C (-148 to 1022°F).

Connection head:

- Cast iron: 260°C (500°F) max.
- Aluminum: 316°C (600°F) max.
- Stainless steel: 121°C (250°F) max.

Material:

- Probe: 316 stainless steel.
- Connection head: Cast iron, aluminum, or stainless steel.
- Thermowell: 316 stainless steel.
- Extension: Stainless steel.

Pressure rating: 7000 psi (483 bar) at 21°C, reducing to 2500 psi (172 bar) at 550°C.

Standard U dimensions: 2.5, 4.5, 6.0, 7.5, 8.0, 10.5, 13.5, 16.5, and 22.5".

Insulation resistance: 10 megohms min. at 100 VDC, leads to case.

Connection: Terminal block for wires to 14 AWG.

Time constant: 23 seconds typical in moving water.

Sensing elements

Element		Code
Platinum (0.00391 TCR)	100 Ω ±0.1% at 0°C	PB
Platinum (0.00385 TCR) (Meets EN60751, Class B)	100 Ω ±0.1% at 0°C	PD

Temperature Transmitters

Minco's Temptran™ RTD transmitters provide a 4 to 20 mA signal or HART® Protocol that can be sent over long distances with a simple 2-wire system. See Section 4 for complete temperature transmitter specifications.

Special high-accuracy calibration: For high system accuracy, specify transmitters with matched calibration. Calibration data traceable to NIST will also be provided. Get more information on page 4-22.

Specification and order options

AS5160	Assembly number AS5160
PB	Sensing element from table
105	Thermowell length U: Specify in 0.1" increments (Ex: 105 = 10.5 inches)
Z	Leads per sensing element: Y = 2 leads Z = 3 leads X = 4 leads (PD elements only)
2	Conduit thread: 1 = 1/2 - 14 NPT 2 = 3/4 - 14 NPT
C	Connection head: C = Cast iron A = Aluminum S = Stainless steel
1	Thermowell process thread: 1 = 1/2 - 14 NPT 2 = 3/4 - 14 NPT
U	Extension option: P = Coupling/nipple extension N = No extension U = Union/Nipple extension
To order sensor assembly, stop here.	
To order with transmitters add:	
508	Temptran™ transmitter model: 211 = TT211: Fixed Range (2-lead RTDs) 508 = TT508: Programmable (2 & 3-lead RTDs) 511 = TT511: HART® Programmable (2, 3, & 4-lead RTDs)
A	Temperature range codes starting on page 4-20 or at www.minco.com
1	Calibration: 1 = Nominal calibration 2 = Match calibrated, 0.75% total system accuracy. For other calibration options, contact Minco
AS5160PB105Z2C1U508A1 = Sample part number	

▼ = STANDARD OPTIONS

Specifications subject to change

550°C Thermocouples with Thermowells

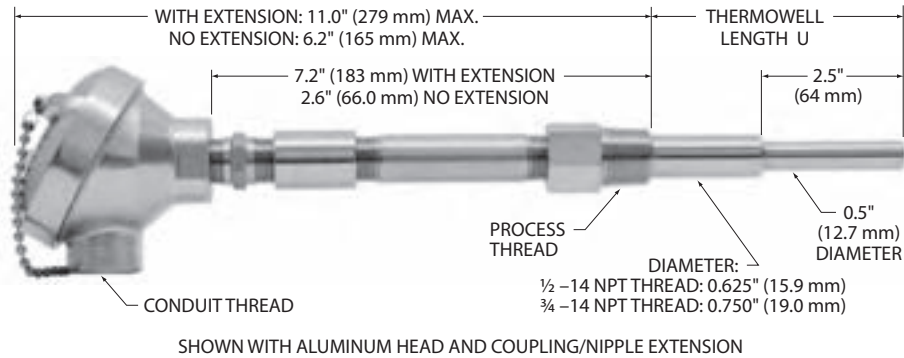

Overview

Sense temperature in high-pressure fluids and gases. These assemblies are spring-loaded for positive probe contact against the bottom of the thermowell.

Note: For temperatures less than 260°C (500°F), assemblies using tip-sensitive sensors are recommended.

- 316 stainless steel thermowell
- Thermocouple probe for use to 550°C (1022°F)
- Spring-loaded probe
- Cast iron, aluminum or stainless steel connection head

Specifications

Temperature range:

Thermowell and sensor: -100 to 550°C (-148 to 1022°F).

Connection head:

Cast iron: 260°C (500°F) max.

Aluminum: 316°C (600°F) max.

Stainless steel: 121°C (250°F) max.

Material:

Probe: 316 stainless steel.

Connection head: Cast iron, aluminum, or stainless steel.

Thermowell: 316 stainless steel.

Extension: Stainless steel.

Pressure rating: 7000 psi (483 bar) at 21°C, reducing to 2500 psi (172 bar) at 550°C.

Standard U dimensions:

2.5, 4.5, 6.0, 7.5, 8.0, 10.5, 13.5, 16.5, and 22.5".

Insulation resistance: 10 megohms min. at 100 VDC, leads to case. Ungrounded junctions only.

Connection: Terminal block for wires to 14 AWG.

Time constant: 60 seconds typical in moving water.

Temperature Transmitters

Minco's Temptran™ thermocouple transmitters provide a 4 to 20 mA signal or HART® Protocol that can be sent over long distances with a simple 2-wire system. See Section 4 for complete temperature transmitter specifications.

Specification and order options

AS5165	Assembly number: AS5165
K	Junction type: E = Chromel-Constantan J = Iron-Constantan K = Chromel-Alumel
U	Junction Grounding: G = Grounded U = Ungrounded
135	Thermowell length U: Specify in 0.1" increments (Ex: 135 = 13.5 inches)
P	
1	Conduit thread: 1 = 1/2 - 14 NPT 2 = 3/4 - 14 NPT
C	Connection head: C = Cast iron A = Aluminum S = Stainless steel
1	Thermowell process thread: 1 = 1/2 - 14 NPT 2 = 3/4 - 14 NPT
U	Extension option: P = Coupling/nipple extension N = No extension U = Union/Nipple extension
To order sensor assembly, stop here. To order with transmitter, add:	
509	Temptran™ transmitter model: 205 = TT205: Fixed Range, Miniature 509 = TT509: Programmable, Hockey Puck 511 = TT511: HART® Programmable, Hockey Puck
A	Temperature range codes starting on page 4-20 or at www.minco.com
AS5165KU135P1C1U509A = Sample part number	

▼ = STANDARD OPTIONS
Specifications subject to change

Hazardous Area Sensor Assemblies

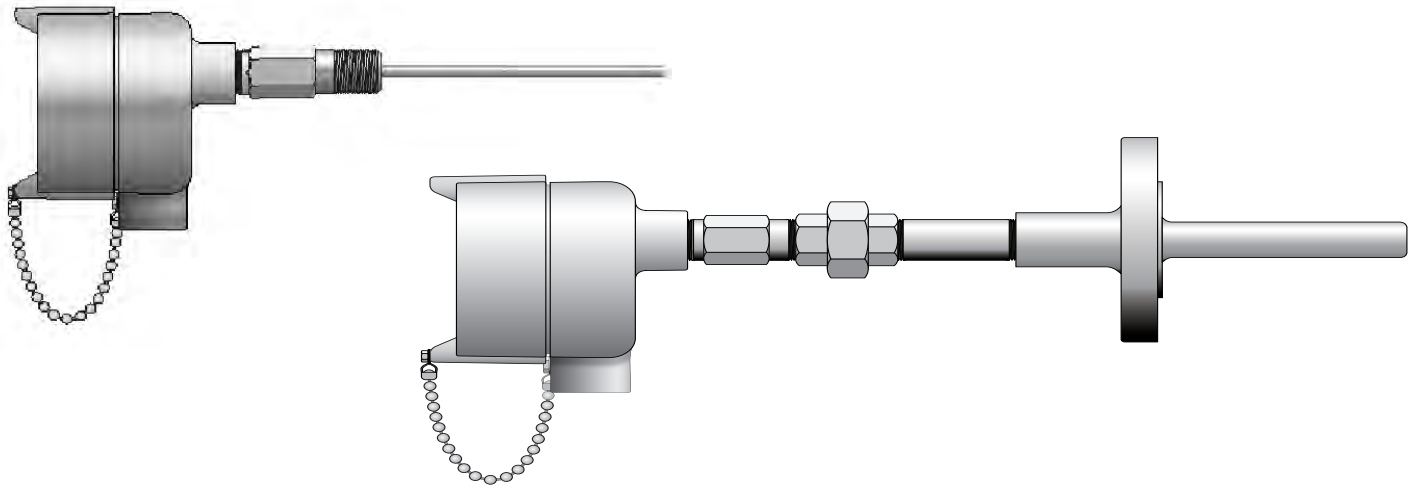

Overview

Whether you need to monitor bearing temperature, process temperature, or virtually any temperature in a hazardous area, Minco's AS9 series temperature sensor assembly can be configured to fit your application, and is certified to satisfy your requirements. Minco's AS9 series temperature sensors offers a single product with global certifications simplifying inventory management and reducing the complexities associated with complying with multiple regional standards.

- **Approval agencies:** IECEx, ATEX, CSA Canada (Canada and United States)
- **Area classifications:** Zone 0, Zone 1, Zone 2, Class I Division 1, Class I Division 2
- **Protection methods:** flameproof (Ex d), increased safety (Ex e), intrinsic safety (Ex i), explosionproof (XP), dustignitionproof (DIP), dust ignition protection by enclosure (Ex tb)
- **Probe options:** tip-sensitive, all stainless steel, mineral insulated
- **Output options:** resistance (RTD), voltage (thermocouple), current (4-20 mA), digital (HART®)
- **Fitting options:** spring-loaded, welded, union/nipple, ½-14 NPT, G ½ (ISO 228-1)
- **Connection head options:** copper-free aluminum (IP66/NEMA 4), powder coated aluminum (IP66/NEMA 4X), stainless steel (IP66/NEMA 4X), various conduit threads
- **Thermowell options:** threaded, flanged, tapered, reduced tip

Certifications

Minco's AS9 sensors are certified by multiple agencies. Consult the following list to learn more:



IECEx (IEC 60079):

Ex ia IIC T6...T2 Ga IP66
Ex db IIC T6...T2 Gb IP66
Ex tb IIIC T85...T160°C Db



ATEX (EN 60079):

II 1 G Ex ia IIC T6...T2 Ga IP66
2 G Ex db IIC T6...T2 Gb IP66
2 D Ex tb IIIC T85...T160°C Db



CSA Canada (CSA C22.2):

Class I, Zone 0, AEx ia IIC T6...T2
Class I, Zone 1, Ex db IIC T6...T2
Class II, Zone 21, Ex tb IIIC T85...T160°C
IS/XP Class I, Division 1, Groups B, C, D T6...T2
Class II, Division 1, Groups E, F, G T85...T160°C
Class III, Division 1

CSA USA (NEC 500 & 505):

Class I, Zone 0, AEx ia IIC T6...T2
Class I, Zone 1, AEx db IIC T6...T2
Class II, Zone 21, AEx tb IIIC T85...T160°C
IS/XP Class I, Division 1, Groups B, C, D T6...T2
Class II, Division 1, Groups E, F, G T85...T160°C
Class III, Division 1

Hazardous Area Sensor Assemblies

Select Probes and Fittings

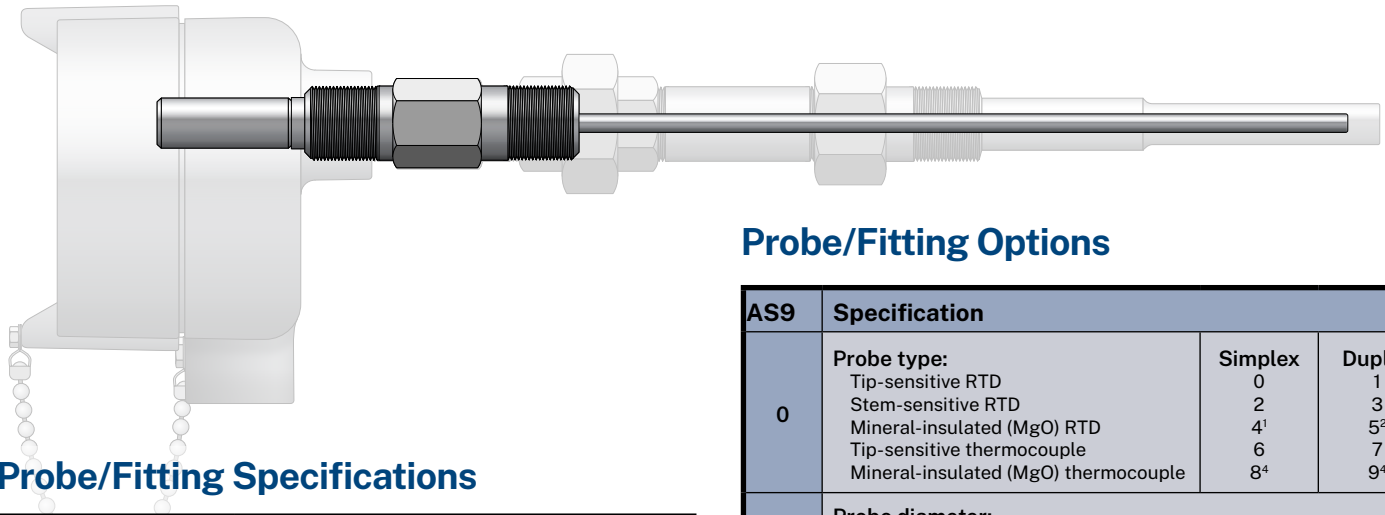

Probe/Fitting Specifications

Probe Type	Temperature Range Probe/Process
0, 1, 2, 3, 6, 7	-50 to 260°C (-58 to 500°F)
4, 5, 8, 9	-50 to 600°C (-58 to 1112°F)

Fitting Type	Pressure Rating
0, 3, 5, 8	50 psi (3.4 bar)
1, 6	715 psi (49.3 bar)
2, 7	None

Probe Type	Material (probe)
0, 1, 6, 7	Stainless steel with copper alloy tip for faster time response
2, 3, 4, 5, 8, 9	Stainless steel

Probe/Fitting Options

AS9	Specification																		
0	<table border="1"> <thead> <tr> <th>Probe type:</th> <th>Simplex</th> <th>Duplex</th> </tr> </thead> <tbody> <tr> <td>Tip-sensitive RTD</td> <td>0</td> <td>1</td> </tr> <tr> <td>Stem-sensitive RTD</td> <td>2</td> <td>3</td> </tr> <tr> <td>Mineral-insulated (MgO) RTD</td> <td>4¹</td> <td>5²</td> </tr> <tr> <td>Tip-sensitive thermocouple</td> <td>6</td> <td>7</td> </tr> <tr> <td>Mineral-insulated (MgO) thermocouple</td> <td>8⁴</td> <td>9⁴</td> </tr> </tbody> </table>	Probe type:	Simplex	Duplex	Tip-sensitive RTD	0	1	Stem-sensitive RTD	2	3	Mineral-insulated (MgO) RTD	4 ¹	5 ²	Tip-sensitive thermocouple	6	7	Mineral-insulated (MgO) thermocouple	8 ⁴	9 ⁴
Probe type:	Simplex	Duplex																	
Tip-sensitive RTD	0	1																	
Stem-sensitive RTD	2	3																	
Mineral-insulated (MgO) RTD	4 ¹	5 ²																	
Tip-sensitive thermocouple	6	7																	
Mineral-insulated (MgO) thermocouple	8 ⁴	9 ⁴																	
0	Probe diameter: 0 = 6.4 mm (.250") 1 = 6.0 mm (.236") 2 = 5.5 mm (.215") 3 = 5.5 mm (.215"); thick wall for bending by hand 4 = 4.8 mm (.188")																		
0	Process thread \ fitting type: 0 = 1/2-14 NPT \ release knob spring-loaded 1 ²³ = 1/2-14 NPT \ welded 2 ¹ = 1/2-14 NPT \ fixed spring-loaded 3 = 1/2-14 NPT \ set screw spring-loaded 5 = G 1/2 \ release knob spring-loaded 6 ²³ = G 1/2 \ welded 7 ¹ = G 1/2 \ fixed spring-loaded 8 = G 1/2 \ set screw spring-loaded																		
AS9000PD100W3A0X0X1N1 = Sample part number																			

1- Only available for Probe diameter options 0, 1

2- Only available for Probe diameter option 0

3- Only available for Probe type options 2, 3, 4, 5, 8, 9

4- Not available for Probe diameter option 2

Insulation resistance:

- 1000 megohms min at 100 VDC, leads to case.
- 100 megohms min at 100 VDC, leads to case (ungrounded junction thermocouples).
- 10 megohms min at 100 VDC, leads to case (mineral insulated RTDs and ungrounded mineral insulated thermocouples)

Dielectric strength:

- 600 Vrms at 60 Hz for 2 seconds with 5 mA maximum leakage current (probe leads to connection head).

**Not seeing your ideal configuration?
Contact us for a custom solution!**

Hazardous Area Sensor Assemblies

Select Sensing Element, Insertion Depth, and Lead Configuration

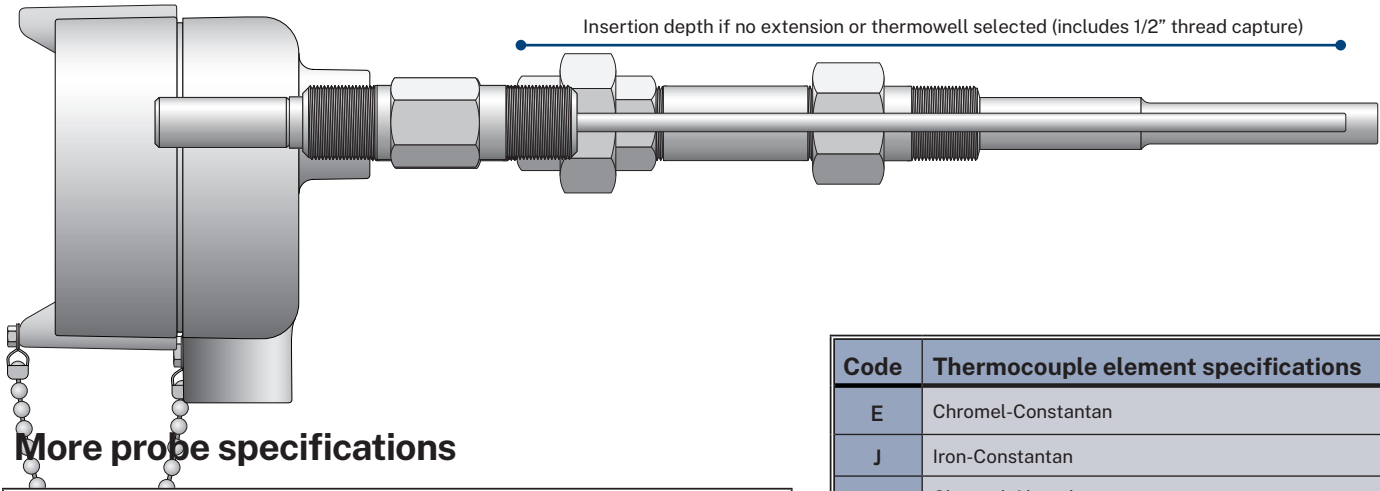

More probe specifications

Code	RTD element specifications
PA	Platinum (0.00392 Ω/Ω/°C); 100 Ω ±0.5% at 0°C Accuracy: ±1.3°C at 0°C
PD	Platinum (0.00385 Ω/Ω/°C); 100 Ω ±0.12% at 0°C Accuracy: ±0.3°C at 0°C (EN60751 Class B)
PM	Platinum (0.00385 Ω/Ω/°C); 100 Ω ±0.06% at 0°C Accuracy: ±0.15°C at 0°C (EN60751 Class A)
PF ⁷	Platinum (0.00385 Ω/Ω/°C); 1000 Ω ±0.12% at 0°C Accuracy: ±0.3°C at 0°C (EN60751 Class B)
PW ⁷	Platinum (0.00375 Ω/Ω/°C); 1000 Ω ±0.12% at 0°C Accuracy: ±0.3°C at 0°C
CA ⁵⁷	Copper (0.00427 Ω/Ω/°C); 10 Ω ±0.2% at 25°C Accuracy: ±0.5°C at 25°C
CC ⁶⁷	Copper (0.00427 Ω/Ω/°C); 10 Ω ±0.5% at 25°C Accuracy: ±1.3°C at 25°C
NA ⁷	Nickel (0.00672 Ω/Ω/°C); 120 Ω ±0.5% at 0°C Accuracy: ±0.8°C at 0°C
NB ⁶	Nickel (0.00618 Ω/Ω/°C); 100 Ω ±0.22% at 0°C Accuracy: ±0.4°C at 0°C (DIN 43760 Ni 100)

5 - Simplex only
 6 - Duplex only
 7 - Not available for Probe type options 4, 5
 Note: See interchangeability tables for accuracy over the entire temperature range.

Code	Thermocouple element specifications
E	Chromel-Constantan
J	Iron-Constantan
K	Chromel-Alumel
T	Copper-Constantan
_G	Grounded: thermocouple junction internally grounded to case
_U	Ungrounded: thermocouple junction electrically isolated from case

Thermocouple accuracy:
 Standard tolerances per ASTM E230/E230M.

Insertion depth:

- If no thermowell or nipple/union extension, measured from thread engagement on fitting as shown in diagram above. If nipple/union extension but no thermowell, measured from thread engagement on nipple. If threaded thermowell, measured from end of thermowell threads as shown in diagram on page 5. If flanged thermowell, measured from face of flange as shown in diagram on page 5.
- Minimum: 35mm (only applies when no extension and/or no thermowell are specified).
- Maximum: 3048mm probe length. (Maximum insertion depth will vary, depending on selected options.)

Probe/Sensing Element Options

AS9	Specification
PD	Sensing element For RTD enter two letter code from table on left. For Thermocouple, enter E, J, K or T thermocouple type plus U or G for junction type as shown above.
100	Insertion depth (mm)
W	Leads per sensing element (colors shown are first element \ optional second element) Y ⁸ = 2 (1-red/1-white\1-yellow/1-blue) V ⁸⁹ = 2 (1-white/1-red\1-yellow/1-black) (EN60751) Z = 3 (1-red/2-white\1-blue/2-yellow) W = 3 (1-white/2-red\1-yellow/2-black) (EN60751) X = 4 (2-red/2-white\2-yellow/2-blue) U ⁹ = 4 (2-white/2-red\2-yellow/2-black) (EN60751) P = thermocouple (colors per ASTM E230/E230M)
AS900PD100W3A0X0X1N1 = Sample part number	

8 - Not available for Sensing element options CA, CC
 9 - Not available for simplex probe types.

Hazardous Area Sensor Assemblies

Select Optional Thermowell

Thermowell Specifications

1. Specify thermowell type

Code	Thermowell type
A	1" RF (Raised Face)
B	1.5" RF (Raised Face)
C	2" RF (Raised Face)
D	3" RF (Raised Face)
E	1" RTJ (Ring Type Joint)
F	1.5" RTJ (Ring Type Joint)
G	2" RTJ (Ring Type Joint)
H	3" RTJ (Ring Type Joint)
J	Threaded, reduced tip
K	Threaded, tapered
X0	No thermowell (skip 2a and 2b)

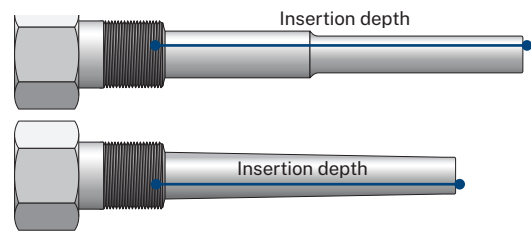
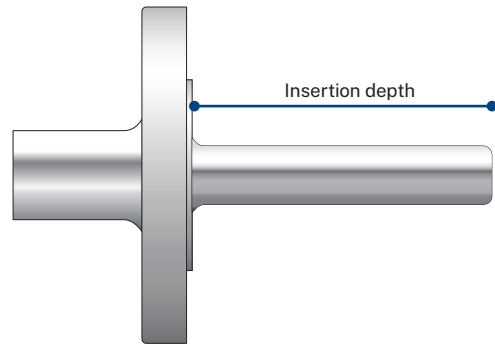

2a. If Flange mount thermowell, specify rating and shaft design

Code	Rating and shaft design
0	150# tapered
1	300# tapered
2	600# tapered
3	900#/1500# tapered
4	2500# tapered
5	150# straight
6	300# straight
7	600# straight
8	900#/1500# straight
9	2500# straight

2b. If Thread mount (code J or K) thermowell, specify process thread

Code	Process thread
0	1/2 - 14 NPT
1	3/4 - 14 NPT
2	1 - 11/2 NPT
3	G 1/2

3. Specify thermowell material

Code	Material
X	No thermowell
A	Type 316/316L SST
B	Type 304 SST
J	Hastelloy C-276
K	Monel 400
N	Carbon Steel C1018

Thermowell Options

Code	Specification
X	Thermowell mounting type: select code from table 1 at left
0	Thermowell rating/shaft or thread: select code from table 2a or 2b at left
X	Thermowell material: select code from table 3 above
AS9000PD100W3A0X0X1N1 = Sample part number	

Hazardous Area Sensor Assemblies

Finish the part number by specifying your transmitter choice

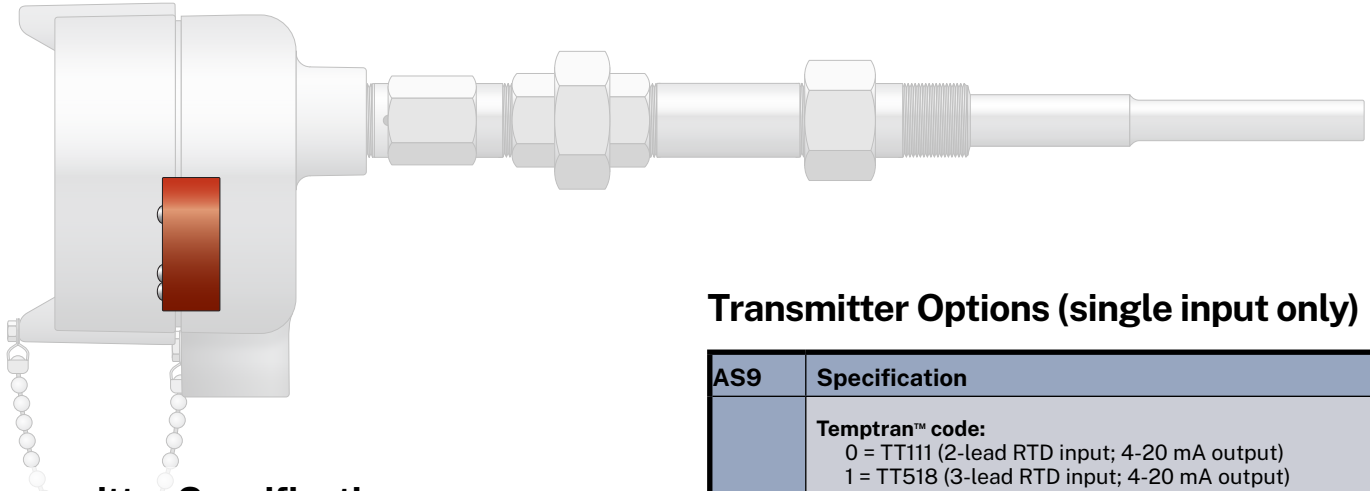

Transmitter Specifications

Note: TT111 series transmitter is certified only for North America use in explosionproof (XP) and flameproof (Ex d) applications

Temptran™ code	Base model number	Agency approvals
1	TT518	ATEX CSA (USA and Canada) IECEX
2	TT519	ATEX IECEX
6	TT520	ATEX CSA (USA and Canada) IECEX
7	TT521	ATEX CSA (USA and Canada) IECEX

Transmitter Options (single input only)

AS9	Specification
1	Temptran™ code: 0 = TT111 (2-lead RTD input; 4-20 mA output) 1 = TT518 (3-lead RTD input; 4-20 mA output) 2 = TT519 (thermocouple input; 4-20 mA output) 5 = TT246 (3-lead RTD input; 1-5 VDC output) 6 = TT520 (any input; 4-20 mA output) 7 = TT521 (any input; 4-20 mA output + HART®)
N	Temperature range code: For a list of Temperature range codes, download a Sensors Design Guide from Minco.com or contact Minco for additional range options.
1	Calibration (options 2, 3, 4 available for Simplex RTD configurations only): 1 = Calibrated to sensing element nominal values 2 = Match calibrated for ±0.75% of span system accuracy 3 = Match calibrated for ±0.50% of span system accuracy 4 ¹¹ = Match calibrated for ±0.20% of span system accuracy
AS9000PD100W3A0X0X1N1 = Sample part number	

¹¹ - System accuracy = ±0.20% of span or ±0.1°C, whichever is greater.

Calibration

Transmitters can be calibrated to nominal resistance values of the RTD (Calibration option 1). Total system error includes the tolerances of both the transmitter and the RTD sensor. Match calibration (Calibration options 2, 3, 4) uses actual resistance of the RTD to calibrate the transmitter. This effectively eliminates the sensor tolerance from system accuracy calculations. A calibration report with traceability to NIST and/or SI is provided with Calibration option 2, 3, or 4.

Calibration options 2, 3, and 4 are not available for thermocouples or duplex RTDs.

Eurostyle Sensors

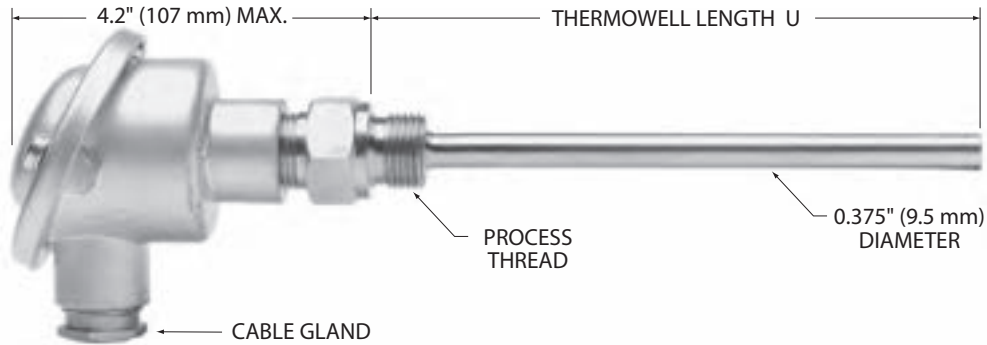

Overview

These low priced assemblies come complete with thermowells, spring-loaded probes, and connection heads. They provide accurate sensing and quick response in liquid or air streams. Specify U.S. or metric thread for global compatibility.

- Compact, economical RTD or thermocouple assembly
- Metric straight thread or U.S. tapered thread
- Tip-sensitive probe for use to 260°C (500°F)
- Optional European Form B connection head to DIN 43729
- Stainless steel thermowell

Temperature Transmitters

Minco's Temptran™ RTD transmitters provide a 4 to 20 mA signal or HART® Protocol that can be sent over long distances with a simple 2-wire system. See Section 4 for complete temperature transmitter specifications.

Special high-accuracy calibration: For high system accuracy, specify transmitters with matched calibration. Calibration data traceable to NIST will also be provided. Get more information on page 4-22.

Specifications

Temperature range: -50 to 260°C (-58 to 500°F).

Material:

Probe: Stainless steel with copper alloy tip.

Connection head: Cast aluminum.

Thermowell: 300 series stainless steel.

Pressure rating: 2755 psi (190 bar) at 25°C, reducing to 493 psi (34 bar) at 600°C.

Insulation resistance: 10 megohms min. at 100 VDC, leads to case. Ungrounded junctions only on thermocouples.

Connection: Terminal block for wires to 14 AWG.

Time constant: Typical in moving water:

RTD: 35 seconds.

Thermocouple: 27 seconds.

▼ = STANDARD OPTIONS

Specifications subject to change

Eurostyle Sensors

Sensing elements

RTD sensing element		Code
Platinum (0.00392 TCR)	100 Ω \pm 0.5% at 0°C	PA
Platinum (0.00385 TCR) (Meets EN60751, Class B)	100 Ω \pm 0.1% at 0°C	PD
Platinum (0.00385 TCR)	100 Ω \pm 0.5% at 0°C	PE
Copper	10 Ω \pm 0.2% at 25°C	CA
(dual) (0.00427 TCR)	10 Ω \pm 0.5% at 25°C	CC
Nickel (0.00672 TCR)	120 Ω \pm 0.5% at 0°C	NA

RTD specification and order options

AS5240	Assembly number: AS5240: Single element RTD AS5241: Dual element RTD
PD	Sensing element from table
40	TW length U in 0.1" increments [Ex: 40 = 4.0 inches (102 mm)]
Z	Leads per sensing element: Y = 2 leads Z = 3 leads (required for CA/CC) X = 4 leads (single element only)
2	Conduit thread: 1 = 1/2 - 14 NPT 2 = 3/4 - 14 NPT 3 = PG cable gland (Eurostyle only)
A	Connection head: A = Standard aluminum head E = Eurostyle aluminum head
1	TW process thread: 1 = 1/2 - 14 NPT 2 = 3/4 - 14 NPT 3 = ISO 228/1 - G 1/2
To order sensor assembly, stop here. To order with transmitters, add:	
TT520	Temptran™ model: TT520: Programmable (2, 3, & 4-lead RTDs) TT521: HART® Programmable (2, 3, & 4-lead RTDs)
A	Temperature range codes starting on page 4-20 or at www.minco.com
1	Calibration: 1 = Nominal calibration 2 = Match calibrated, 0.75% total system accuracy. For other calibration options, contact Minco
AS5240PD40Z2A1TT520A1 = Sample part number	

Thermocouple specification and order options

AS5245	Assembly number: AS5245: Single junction TC AS5246: Dual junction TC
E	Junction type: E = Chromel-Constantan J = Iron-Constantan K = Chromel-Alumel T = Copper-Constantan
G	Junction grounding: G = Grounded U = Ungrounded
135	TW length U in 0.1" increments Specify in 0.1" increments [Ex: 135 = 13.5 inches (343 mm)]
P	
3	Conduit thread: 1 = 1/2 - 14 NPT 2 = 3/4 - 14 NPT 3 = PG cable gland (Eurostyle only)
E	Connection head: A = Standard aluminum head E = Eurostyle aluminum head
3	TW process thread: 1 = 1/2 - 14 NPT 2 = 3/4 - 14 NPT 3 = ISO 228/1 - G 1/2
To order sensor assembly, stop here. To order with transmitters, add:	
TT520	Temptran™ model: 520 = TT520: Programmable, Hockey Puck 521 = TT521: HART® Programmable, Hockey Puck
A	Temperature range codes starting on page 4-20 or at www.minco.com
AS5245EG135P3E3520A = Sample part number	

▼ = STANDARD OPTIONS
Specifications subject to change



Specifying Custom Assemblies

The standard assemblies in this section will fit a wide variety of installations. However, for more versatility you can create new assemblies from the probes, accessories, and transmitters in the pages listed.

Follow these steps:

1. Choose a probe

Select an RTD or thermocouple from Section 2. The section includes tip-sensitive, high temperature, and fast response models. Some have integral fittings or bayonet lockcaps.

Factors to consider are:

- Temperature rating
- Compatibility with receiving instruments
- Probe style and diameter
- Accuracy vs. cost

2. Add a fitting

See Section 3 for probe mounting fittings. Adjustable fittings, combined with cut-to-length probes, allow instant fabrication of assemblies to any length required. Included are spring-loaded holders, pressure fittings, and bayonet-style fittings.

Factors to consider are:

- Temperature rating
- Probe diameter
- Correct NPT threads
- Pressure ratings
- Compatibility with environment

3. Select a thermowell

Thermowells protect sensors from the effects of fluid flow and pressure. See Section 3 for a variety of well styles and materials.

Factors to consider are:

- Pressure rating
- Compatibility with fluid media
- Insertion depth
- Correct NPT thread

4. Attach a connection head

Finish off your assembly with a connection head for termination to remote extension wires. See page 3-2 for specifications.

Factors to consider are:

- Connection head size
- Temperature rating
- Correct pipe threads for fitting and conduit
- Number of terminals or wire nuts
- Hazardous area requirements

5. Install a transmitter

Transmitters convert sensor output to a 4 to 20 mA current signal, immune to leadwire resistance. See Section 4 for RTD and thermocouple transmitters.

Factors to consider are:

- Transmitter accepts sensor input
- Transmitter fits connection head
- Ambient temperature range acceptable

6. How to calculate probe length

All Minco fittings have probe length adders to help you determine total probe length. Total length L is the insertion depth D plus the adder A.

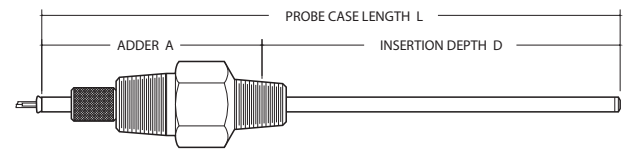

Thermowell drawings show an adder to convert thermowell length U to insertion depth D. Then use D plus the fitting adder A to find total probe length L.

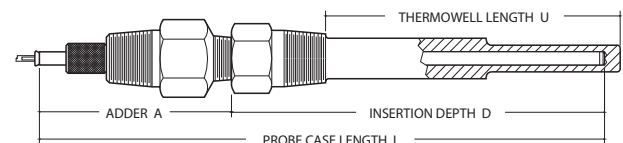

▼ = STANDARD OPTIONS
Specifications subject to change