



HMS80 Series Humidity and Temperature Transmitters

For Outdoor Measurements in Building Automation Applications



Features

- Reliable outdoor transmitters with integrated radiation shields
- ± 3 %RH accuracy
- User-exchangeable INTERCAP® sensor for easy field replacement
- Default output parameters are relative humidity and temperature. Dew point temperature, wet bulb temperature, and enthalpy outputs selectable using DIP switches
- Options for both current and voltage outputs
- Ingress protection IP65

Vaisala HMS80 Series INTERCAP® Humidity and Temperature Transmitters are designed for outdoor measurements in various building automation applications. These ± 3 % transmitters include an integrated radiation shield to reduce the influence of solar radiation on temperature and humidity measurements.

Easy Installation

HMS80 transmitters are easy to install. They can be mounted directly onto a wall or pole without any extra accessories. There are no loose parts, screws are retained in the enclosure, all connectors are clearly labeled, and the connectors are within easy reach.

For fast and convenient configuration, the most popular control parameters in free cooling control – dew point temperature, wet bulb temperature, and enthalpy – are selectable using DIP switches.

Low Maintenance

HMS80 series transmitters require minimal maintenance thanks to their excellent sensor stability and high-quality materials. If necessary, the INTERCAP® sensor can easily be replaced in the field with minimum downtime.

Technical Data

Models

Model	Type	Output	IP Rating
HMS82	Outdoor, RH+T	2-wire, current output	IP65
HMS83	Outdoor, RH+T	3-wire, voltage output	IP65

Measurement Performance

Relative Humidity

Measurement range	0 ... 100 %RH
Accuracy at temperature range +10 ... +30 °C (+50 ... +86 °F):	
0 ... 90 %RH	±3 %RH
90 ... 100 %RH	±5 %RH
Accuracy at temperature range -20 ... +10 °C, +30 ... +60 °C: (-4 ... +50 °F, +86 ... +140 °F)	
0 ... 90 %RH	±5 %RH
90 ... 100 %RH	±7 %RH
Accuracy in temperature range -40 ... -20 °C (-40 ... -4 °F):	
0 ... 100 %RH	±7 %RH
Stability in typical HVAC applications	±2 %RH over 2 years
Humidity sensor	Vaisala INTERCAP®

Temperature

Measurement range	-40 ... +60 °C (-40 ... +140 °F)
Accuracy at +20 °C (+68 °F)	±0.3 °C (±0.54 °F)
Temperature dependence	±0.01 °C/°C
Temperature sensor	Pt1000 RTD Class F0.1 IEC 60751

Calculated Parameters ¹⁾

Measurement range for dew point temperature and wet bulb temperature	-40 ... +60 °C (-40 ... +140 °F)
Measurement range for enthalpy	-40 ... 460 kJ/kg (-10 ... +190 BTU/lb)
Accuracy at 20 °C (68 °F) and 80 %RH	Dew point: ±0.9 °C (1.6 °F) Wet bulb temperature: ±0.7 °C (1.3 °F) Enthalpy: ±2 kJ/kg (0.9 BTU/lb)

¹⁾ Accuracy of the calculated parameters should be calculated at the actual condition based on the relative humidity and temperature specification.

Inputs and Outputs

Current Output Model HMS82 (2-wire)

Outputs	4 ... 20 mA, loop powered
Loop resistance	0 ... 600 Ω
Supply voltage	20 ... 28 VDC at 600 Ω load 10 ... 28 VDC at 0 Ω load

Voltage Output Model HMS83 (3-wire)

Outputs	0 ... 10 V
Load resistance	10 kΩ min
Supply voltage	18 ... 35 VDC 24 VAC ±20 % 50/60 Hz

Operating Environment

Operating temperature	-40 ... +60 °C (-40 ... +140 °F)
Operating humidity	0 ... 100 %RH
Maximum wind/flow speed	30 m/s (67 mph)
Storage temperature	-40 ... +60 °C (-40 ... +140 °F)
EMC compliance	EN61326-1, Industrial Environment

Mechanical Specifications

Max. wire size	1.5 mm ² (AWG 16)
Standard housing color	White (RAL9003)
Housing material	PC + 10 %GF (UL-V0 approved)

Spare Parts and Accessories

INTERCAP® sensor	15778HM
10 pcs of INTERCAP® sensors	INTERCAPSET-10PCS
Conduit fitting + O-ring (M16 × 1.5 / NPT1/2 Inch)	210675SP
Conduit fitting + O-ring (M16 × 1.5 / PG9, RE-MS)	210674SP
Fastening set HMS80	237805
Membrane Filter	ASM210856SP
Terminal Block, Blue	236620SP

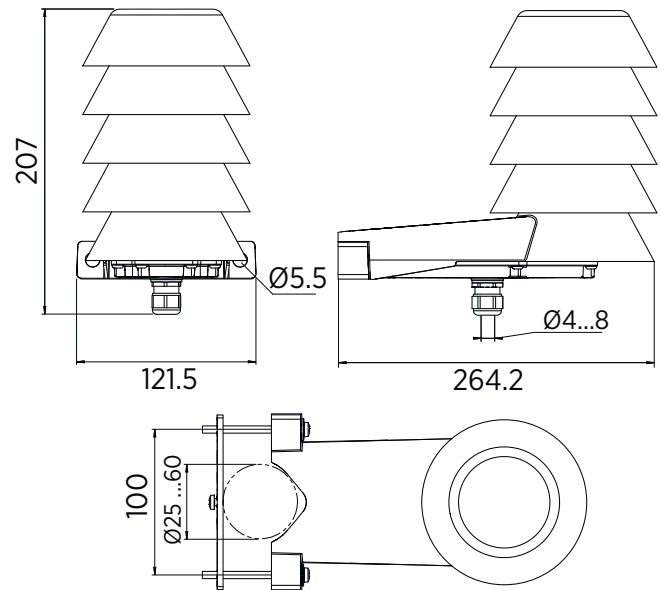

Dimensions in mm

VAISALA

www.vaisala.com