



#### Features

- Designed for high humidity applications
- Dew point measurement range: -40 ... +100 °C
- Patented, warmed probe
- Incorporates Vaisala HUMICAP® Sensor for excellent accuracy and long-term stability and resistance to dust and most chemicals
- Low maintenance need
- Outer cover provides protection from rain and direct sunlight

Vaisala HUMICAP® Turbine Mounting Kit HMT300TMK is developed to monitor the air intake of gas and liquid fueled power turbines. HMT300TMK is used together with HMT337 Temperature and Humidity Transmitter (not included in the HMT300TMK).

HMT300TMK is ideal for measuring in water vapor injection applications because the sensor has been optimized for high humidity environments by utilizing a patented, warmed probe. Water vapor is added to the intake of the turbine to increase the mass flow which in turn increases compression and electrical power output.

#### Low Maintenance

Power turbines also require exact water vapor injection in the chamber to reduce pollutant emissions. Vaisala's warmed probe technology is ideal because of its reliability in the field. In fact, the only suggested scheduled maintenance is annual calibration.

#### Patented, Warmed Probe Prevents Condensation

HMT300TMK, with HMT337 installed, provides fast and reliable dewpoint measurement especially under high humidity conditions where dew would

normally form on the humidity sensor and thereby cause errors in measurement. The patented warmed probe prevents condensation from forming on the sensor.

#### Protective Enclosure

HMT300TMK includes a white, painted stainless steel enclosure with an installation kit for the probe. HMT337 Humidity and Temperature Transmitter is installed in the stainless steel enclosure at the factory, when ordered together with HMT300TMK. The instrument can be equipped to be powered with either 24 VDC/VAC or with an internal 110/230 volt power supply unit.

The outer cover protects the transmitter from direct sunlight and rain. The installation kit protects the probe from outer water splashes, keeps the sensor dry, and prevents any parts that could vibrate loose from entering the turbine.

HMT300TMK can be ordered separately for installation with the customer's existing HMT337.

#### HUMICAP® Performance

HMT330 Series Transmitters are fitted with the latest generation of the HUMICAP®, the polymer sensor known for its accuracy, reliability and long-term stability. The sensor has a high tolerance for particulate abrasion and chemical contamination.

#### Vaisala HUMICAP® Humidity and Temperature Transmitter HMT337

HMT337 is intended for demanding industrial humidity measurement applications with a risk of condensation. The stainless steel probe is mechanically durable and preferred for most industrial applications.

# Technical Data

## Measurement Performance

Dew point measurement range -40 ... +100 °C (-40 ... +212 °F)

Accuracy: find the intersection of the dewpoint temperature curve and the dewpoint difference reading (process temperature - dewpoint temperature) on the x-axis and read the accuracy in dewpoint measurement at the y-axis

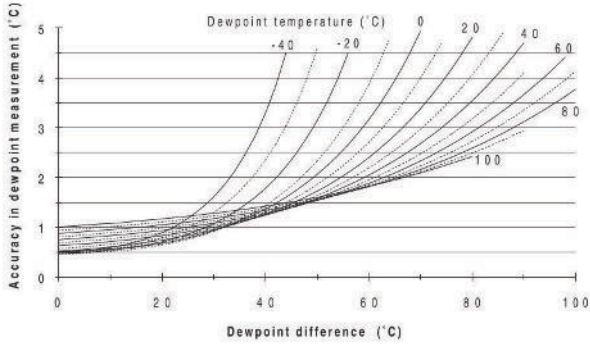

Response time (90 %) at +20 °C (68 °F) 20 s  
in still air (PPS grid with steel netting)

## Inputs and Outputs

Operating voltage 24 VDC/VAC (20 ... 28 V) or 115/230 VAC  
(Must be specified at time of order)

Two standard outputs, third optional 0 ... 20 mA, 4 ... 20 mA, 0 ... 1 V,  
0 ... 5 V, 0 ... 10 V

Typical accuracy of analog output at +20 °C (+68 °F) ±0.05 % full scale

Typical temperature dependence of analog output ±0.005 % / °C full scale

Serial output available RS-232C (optional RS-485)

Recommended external load for current outputs < 500 Ω

For 0 ... 1 V output > 2 kΩ (to ground)

For 0 ... 5 and 0 ... 10 V outputs > 10 kΩ (to ground)

## Mechanical Specifications

Connections Screw terminals for 0.5 mm<sup>2</sup> wires (AWG 20), stranded wires recommended

Housing material G-AISI10 (DIN 1725)

Bushing 8 ... 11 mm diameter cables (0.31 ... 0.43 in)

Humidity sensor protection (Ø 12 mm) PPS grid with steel netting

### Weight

HMT300TMK with HMT337 8.7 kg (19.2 lb)

HMT300TMK with HMT337, packed in a wooden shipping box 13.3 kg (29.3 lb)

## Compliance

IP rating IP65

NEMA rating NEMA 4

## Operating Environment

Operating temperature for electronics -40 ... +60 °C (-40 ... +140 °F)

Storage temperature -55 ... +80 °C (-67 ... +176 °F)

EMC compliance EN61326-1, Industrial Environment

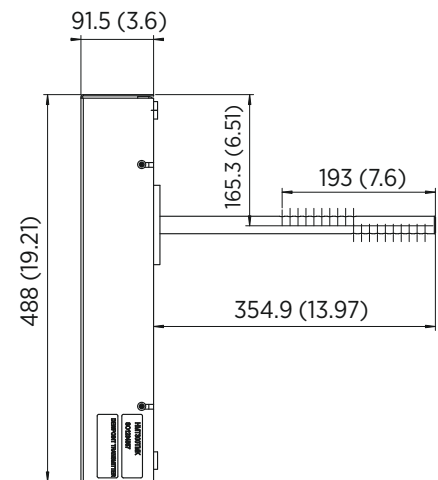
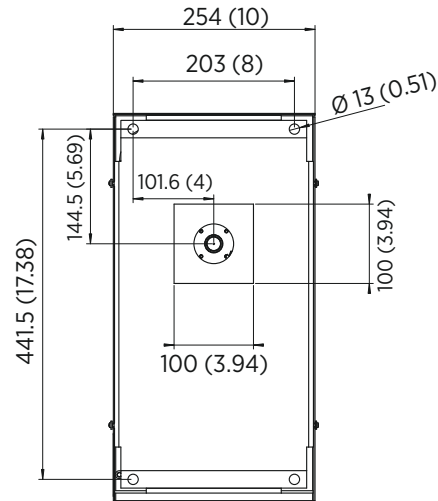

Dimensions in mm (inches)

**VAISALA**

www.vaisala.com