

Product Catalog

Humidity, Temperature, Dew Point, Carbon Dioxide, Moisture in Oil, Continuous Monitoring, Dissolved Gas Analysis, Hydrogen Peroxide, Pressure, Weather, Service Offering

Industrial Measurements



VAISALA

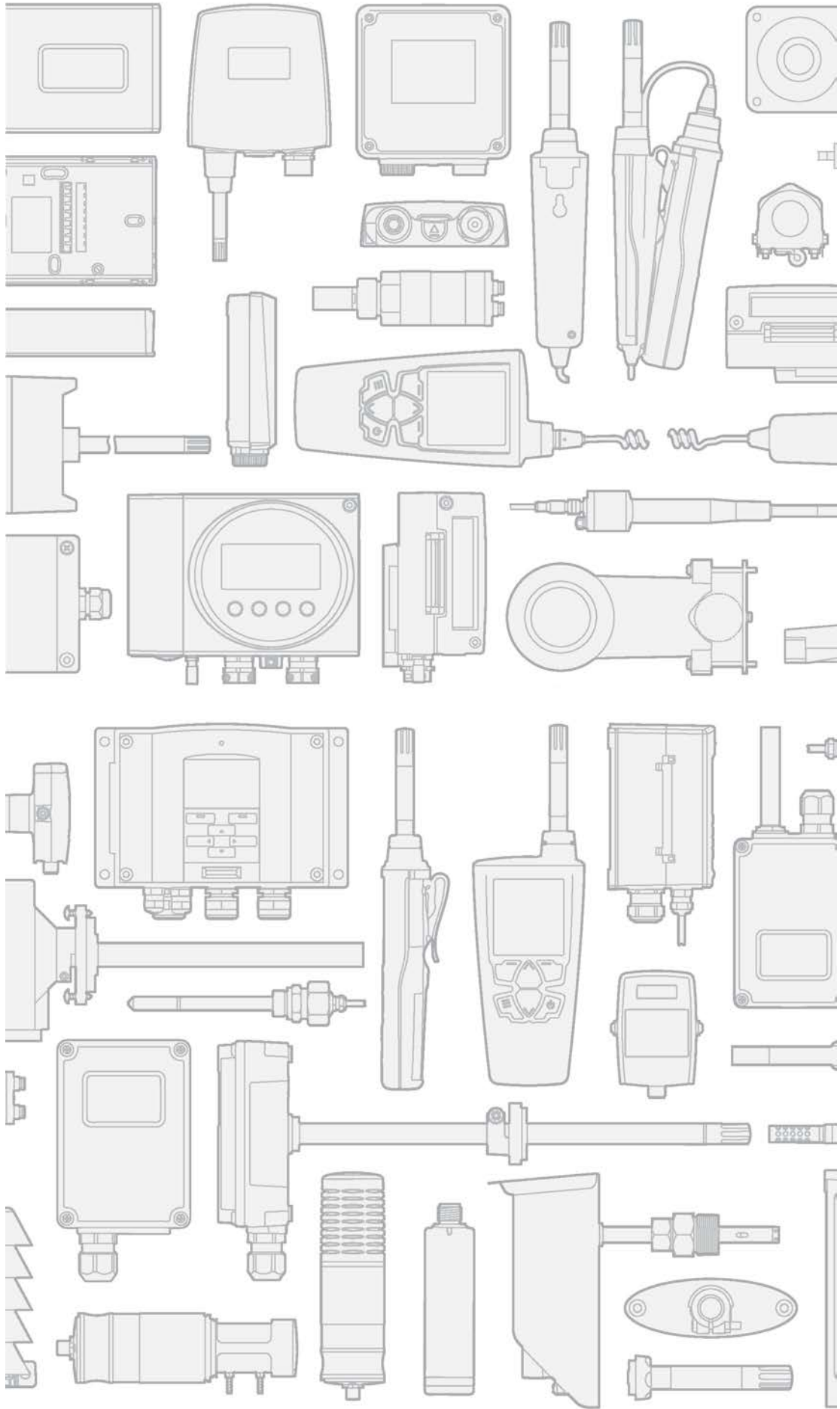

Observations for a Better World

Vaisala Industrial Measurements business area serves customers in multiple industries with over 40 years of industry knowledge. Our products improve quality, productivity, energy efficiency, and help our customers fulfill regulatory compliance. Our customers operate in different types of environments - from semi-conductor factories and high-rise buildings to power plants and small incubators - where reliable measuring and monitoring of the conditions are a prerequisite for successful operations.

Industrial Measurement Solutions

Vaisala's measurement products are used by a variety of industries, such as pharmaceutical, electronics, automotive, maritime, lithium battery manufacturing and food processing. Accurate and reliable real-time measurements extend equipment lifetime, and improve processes, productivity and end-product quality.

Heating, Ventilation, and Air Conditioning (HVAC)

Vaisala offers industry benchmark HVAC transmitters for measuring humidity, temperature, and carbon dioxide indoors and outdoors. Customers use these instruments to optimize heating ventilation and air conditioning controls, for example, in offices, hospitals, data centers, factories, and cooling towers. Our transmitters help in maintaining good indoor air quality and saving costs through improved efficiency.

Life Science and GxP Regulated Environments

Vaisala provides measurement devices and monitoring systems for continuous records, reports and alarms. These solutions are used to monitor for example temperature and humidity conditions in research and development, production, and storage environments. With our solutions and services, life science companies ensure the quality and safety of their products, and maintain compliance with global regulations.

Power Generation and Transmission

For power generation and transmission industry, Vaisala provides unique measurement equipment for online monitoring of transformer insulation oil. Our reliable solutions support in planning and optimizing the preventive maintenance of power transformers, and thus help to extend their lifetime and reduce the risk of unexpected and costly outages.

This product catalog gives an overview of our products to help you select what suits your needs best. For more information, visit us at www.vaisala.com or contact us at www.vaisala.com/requestinfo.



Table of Contents

INDIGO TRANSMITTERS FOR SMART PROBES

Indigo 200 Series Transmitters for Vaisala Smart Probes.....	7
--	---

HUMIDITY AND TEMPERATURE

HMP4 Relative Humidity and Temperature Probe for Pressurized and Vacuum Processes.....	9
HMP5 Relative Humidity and Temperature Probe for High Temperatures.....	11
HMP7 Relative Humidity and Temperature Probe for High Humidities.....	13
HMP8 Relative Humidity and Temperature Probe for Pressurized and Vacuum Processes.....	15
TMP1 Temperature Probe.....	17
HMT330 Series Humidity and Temperature Transmitters for Demanding Humidity Measurement.....	19
HMT360 Series Intrinsically Safe Humidity and Temperature Transmitters for Operation in up to Zone 0 / 20.....	29
HMT310 Series Humidity and Temperature Transmitters for Demanding Industrial Applications.....	35
HMT120 and HMT130 Humidity and Temperature Transmitters.....	38
HMW90 Series Humidity and Temperature Transmitters for High-performance HVAC Applications.....	41
HMD60 Series Humidity and Temperature Transmitters HMD62 and TMD62.....	44
HMDW110 Series Humidity and Temperature Transmitters for High-accuracy Measurements in HVAC Applications.....	46
HMS110 Series Humidity and Temperature Transmitters for High-accuracy Outdoor Measurements in Building Automation Applications.....	49
HMDW80 Series Humidity and Temperature Transmitters for Building Automation Applications.....	51
HMS80 Series Humidity and Temperature Transmitters for Outdoor Measurements in Building Automation Applications.....	55
HMM100 Humidity Module for Environmental Chambers.....	57
HMM105 Digital Humidity Module for OEM Applications.....	59
HMP60 Humidity and Temperature Probe.....	61
HMP63 Humidity and Temperature Probe	63
HMP110 Humidity and Temperature Probe	65
HMP113 Humidity and Temperature Probe	68
HM70 Handheld Humidity and Temperature Meter for Spot-checking Applications.....	70
HM40 Series Handheld Humidity and Temperature Meter.....	73
SHM40 Structural Humidity Measurement Kit	77
HMK15 Humidity Calibrator	80
HMP155 Humidity and Temperature Probe	82
DTR500 Solar Radiation and Precipitation Shields	84
HMT330MIK Meteorological Installation Kit	86
HMT300TMK Turbine Mounting Kit for Power Turbine Intake Air Measurement.....	88

DEW POINT

DMT340 Series Dew Point and Temperature Transmitters for Very Dry Conditions.....	90
DMT345 and DMT346 Dew Point Transmitters for High-temperature Applications.....	96
DMT152 Dew Point Transmitter for Low Dew Point Measurement in OEM Applications.....	101
DMT143 Miniature Dew Point Transmitter for OEM Applications.....	103
DMT143L Dew Point Transmitter for OEM Applications (DMT242 Replacement).....	106
DMT132 Dew Point Transmitter for Refrigerant Dryers.....	108
DM70 Handheld Dew Point Meter for Spot-checking Applications.....	110
DSS70A Portable Sampling System and Sampling Cells for DM70.....	113
DPT146 Dew Point and Pressure Transmitter for Compressed Air.....	115

DPT145 Multiparameter Transmitter for SF6 Gas.....	117
---	-----

CARBON DIOXIDE

GMP343 Carbon Dioxide Probe for Demanding Measurements.....	120
GMP231 Carbon Dioxide Probe for CO ₂ Incubators.....	123
GMP251 Carbon Dioxide Probe for %-level Measurements.....	125
GMP252 Carbon Dioxide Probe for ppm-level Measurements.....	128
GM70 Handheld Carbon Dioxide Meter for Spot-checking Applications.....	131
GMW90 Series Carbon Dioxide, Humidity, and Temperature Transmitters for DCV.....	134
GMW80 Series Carbon Dioxide, Humidity, and Temperature Transmitters for DCV.....	137
GMD20 Series Carbon Dioxide Transmitters For Demand-controlled Ventilation Applications.....	140

MOISTURE IN OIL

MMT330 Moisture and Temperature Transmitter Series for Oil	142
MMT310 Series Moisture and Temperature Transmitters for Oil.....	147
MMT162 Moisture in Oil and Temperature Transmitters for OEM Applications.....	150
MM70 Handheld Moisture and Temperature Meter for Spot-checking in Oil.....	152

CONTINUOUS MONITORING

viewLinc Enterprise Server Version 5.0.....	155
AP10 VaiNet Wireless Access Point	157
RFL100 Wireless Data Logger for Continuous Monitoring Systems.....	159
DL2000 RH and Temperature Data Logger	163
DL4000 Universal Data Logger	165
DL1000-1400 Temperature Data Logger	167
DL1016-1416 Multi-application Temperature Data Logger	171
DL1700 Thermocouple Data Logger	173
Mid-range Data Loggers for Temperature, Humidity, and Contact Channel Measurement.....	175
vNet Power over Ethernet Data Logger Interface.....	178
HMT140 Wi-Fi Data Logger for Multiple Environmental Parameters.....	180
On-site Calibration for Continuous Monitoring Systems.....	183

DISSOLVED GAS ANALYSIS

OPT100 Optimus DGA Monitor.....	185
MHT410 Moisture, Hydrogen, and Temperature Transmitter for Online Transformer Condition Monitoring.....	189

HYDROGEN PEROXIDE

HPP270 Series Probes for Hydrogen Peroxide, Humidity, and Temperature Measurement.....	191
---	-----

PRESSURE

PTU300 Combined Pressure, Humidity, and Temperature Transmitter for Demanding Applications.....	194
PTB330 Digital Barometer For Professional Meteorology, Aviation, and Industrial Users.....	199
PTB330TS Barometric Pressure Transfer Standard Take the Lab to the Field.....	201
PTB210 Digital Barometer.....	204
PTB110 Barometer for Industrial Use.....	207
SPH10/20 Static Pressure Heads for Minimizing Wind Induced Error.....	209
PDT101 Differential Pressure Transmitter	211
PDT102 Differential Pressure Transmitter.....	213

WEATHER

WA15 Wind Set for High-performance Wind Measurement.....	215
WMT700 Ultrasonic Wind Sensor Series	218
WXT530 Weather Transmitter Series.....	221

VAISALA SERVICE OFFERING

Ensure Long-term Data Accuracy.....	224
Vaisala Contact Information.....	227



Features

- Plug-and-play probe connection for Vaisala Indigo-compatible probes:
 - CO₂ probes GMP251 and GMP252
 - Vaporized hydrogen peroxide probe HPP272
 - Humidity and temperature probes HMP4, HMP5, HMP7 and HMP8
 - Temperature probe TMP1
- Wireless interface for configuration and temporary use
- Operating temperature: -40 ... +60 °C, with display -20 ... +60 °C
- LCD color display (optional non-display version for analog model)
- IP65 enclosure
- 24 V power supply input
- Indigo 201: 3 analog outputs (mA or V)
- Indigo 202: RS-485 with Modbus RTU
- 2 configurable relays

Vaisala Indigo 200 series transmitters are host devices for displaying measurement values from Vaisala Indigo compatible probes and/or transmitting them to automation systems through analog signals, Modbus RTU communication or relays.

These probe hosts are plug-and-play devices for current and future Vaisala Indigo compatible probes. The host device has a color LCD display; Indigo 201 is also available as a non-display version that uses an LED indicator for notifications.

Vaisala Indigo compatible probes are connected either directly to the host or by using a cable between Indigo 200 and the probe.

Indigo 200 has a browser-based wireless configuration interface for mobile devices and computers that support a wireless connection (IEEE 802.11 b/g/n WLAN). The host device and the probes connected to it can be configured using the wireless user interface. It also allows for temporary viewing of the measurement data.

The surface of the Indigo 200 enclosure is smooth, which makes it easy to clean. It is also resistant to dust and most chemicals, such as, H₂O₂ and alcohol-based cleaning agents.

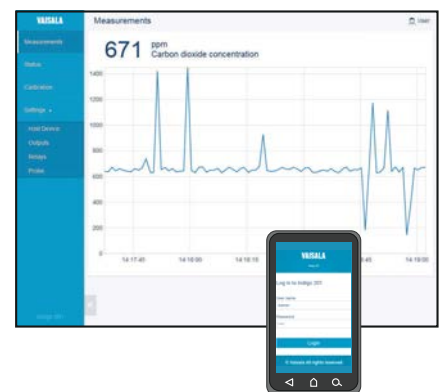

Wireless Configuration Interface Example (Desktop and Mobile Views)

For more information on Indigo transmitters and the Indigo product family, see www.vaisala.com/indigo.

Technical Data

General

- Supports Indigo compatible probes:
 - CO₂ probes GMP251 and GMP252
 - Vaporized hydrogen peroxide probe HPP272
 - Humidity and temperature probes HMP4, HMP5, HMP7 and HMP8
 - Temperature probe TMP1
- LCD color display version (Indigo 201: optional non-display)
- Wireless (WLAN) configuration interface: connect to the Indigo 200 and use the browser-based user interface for device configuration and measurement data viewing.

Operating Environment

Operating temperature	With display -20 ... +60 °C (-4 ... +140 °F) Without display -40 ... +60 °C (-40 ... +140 °F)
Storage temperature	-40 ... +70 °C (-40 ... 158 °F)
Chemical tolerance	Temporary exposure during cleaning: <ul style="list-style-type: none"> • H₂O₂ (6000 ppm, non-condensing) • Alcohol-based cleaning agents such as ethanol and IPA (max. 70 % concentrate)

Inputs and Outputs

Relay contacts x 2	Max. switching power 30 W Max. switching current 1 A Max. switching voltage 40 VDC / 28 VAC
--------------------	---

Indigo 201 Model

Three analog outputs (voltage or current)	Voltage: 0 ... 1 V, 0 ... 5 V, 0 ... 10 V, 1 ... 5 V, scalable, min. load 1 kΩ Current: 4 ... 20 mA, 0 ... 20 mA, scalable, max. load 500 Ω
---	--

Accuracy of analog outputs at 20 °C	± 0.1 % full scale for 0 ... 10 V and 0 ... 20 mA
-------------------------------------	---

Indigo 202 Model

Digital communications	RS-485, Modbus RTU
------------------------	--------------------

Mechanical Specifications

Housing classification	IP65
Housing material	PC/ABS plastic
Display window material	PMMA plastic
Connection screw terminals	26 AWG ... 20 AWG
Weight	402 g (14.2 oz)
Dimensions (H×W×D)	149×135×43 mm (5.87×5.31×1.7 inch)

Compliance

Safety standard	IEC/UL/EN 61010-1
Networking standards (wireless configuration interface WLAN access point)	IEEE 802.11 b/g/n compliant
EMC compliance	EN61326-1, Generic Environment
Contains	FCC ID QOQ-WGM110, IC 5123A-WGM110, MIC 209-J00197, MSIP-CRM-BGT-WGM110

Spare Parts and Accessories

Probe connection cable, 1 m	INDIGOCABLE1M
Probe connection cable, 3 m	INDIGOCABLE3M
Probe connection cable, 5 m	INDIGOCABLE5M
Probe connection cable, 10 m	INDIGOCABLE10M

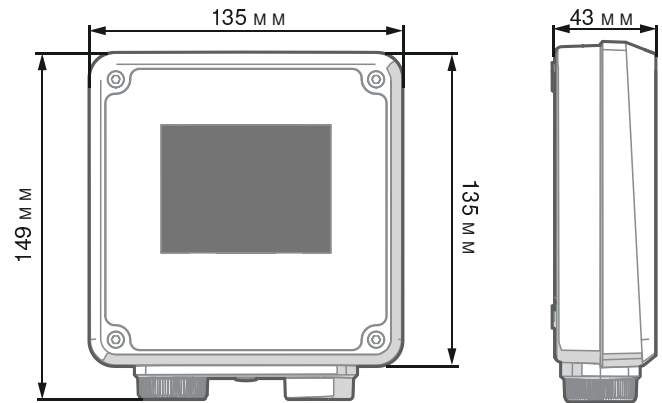

Product Dimensions

Note: All GMP251 and GMP252 probes manufactured from 2017 onwards (serial numbers starting with the letter N or latter in alphabetical order) have full Indigo compatibility.

HMP4 Relative Humidity and Temperature Probe

For Pressurized and Vacuum Processes



Features

- RH accuracy up to 0.8 %RH
- Temperature accuracy up to 0.1 °C (0.18 °F)
- Temperature measurement range -70 ... +180 °C (-94 ... +356 °F)
- Operating pressure 0 ... 10 MPa (0 ... 100 bar)
- Sensor purge provides superior chemical resistance
- Modbus RTU over RS-485
- Plug & play compatible with Indigo series of transmitters
- Traceable calibration certificate: 5 points for humidity, 1 point for temperature

Vaisala HUMICAP® Humidity and Temperature Probe HMP4 is designed for high-pressure applications such as compressed air systems in maritime, breathing air, and industrial applications, where measurement performance and chemical tolerance are essential.

Proven Vaisala HUMICAP® Performance

Vaisala is the original innovator of the thin-film capacitive humidity measurement technology, which has now become the industry standard in humidity measurement.

HUMICAP® technology results from Vaisala's 40-year experience in industrial humidity measurement, providing the best stability, fast response time, and low hysteresis in a wide range of applications.

Chemical Purge Minimizes Effects of Contaminants

In environments with high concentrations of chemicals and cleaning agents, the chemical purge option helps to maintain measurement accuracy between calibration intervals.

The chemical purge involves heating the sensor to remove harmful chemicals. The function can be initiated manually or programmed to occur at set intervals.

Flexible Connectivity

The probe is plug and play compatible with Vaisala Indigo series of transmitters, or it can be used as a standalone digital Modbus RTU transmitter over RS-485 serial bus. For easy-to-use access to field calibration, device analytics, and configuration functionality, the probe can be connected to Vaisala Insight software (for Windows® 7, 8.1 and 10: see www.vaisala.com/insight).

Vaisala Indigo Product Family

Indigo transmitters offer a variety of connectivity options through analog signals or digital outputs, configurable relays, and wireless (WLAN) configuration interface, providing a suitable solution for all industrial humidity measurements. The cable length between the probe and transmitter can be extended to up to 30 meters. For more information, see www.vaisala.com/indigo.

Technical Data

Measurement Performance

Relative Humidity

Sensor	HUMICAP R2 Composite
Measurement range	0 ... 100 %RH
Accuracy at +23 °C (+73.4 °F) ¹⁾	±0.8 %RH (0 ... 90 %RH)
T ₆₃ response time	15 s

Temperature

Sensor	Pt100 RTD Class F0.1 IEC 60751
Measurement range	-70 ... +180 °C (-94 ... +356 °F)
Accuracy ¹⁾	±0.1 °C (±0.18 °F)

¹⁾ Defined against calibration reference

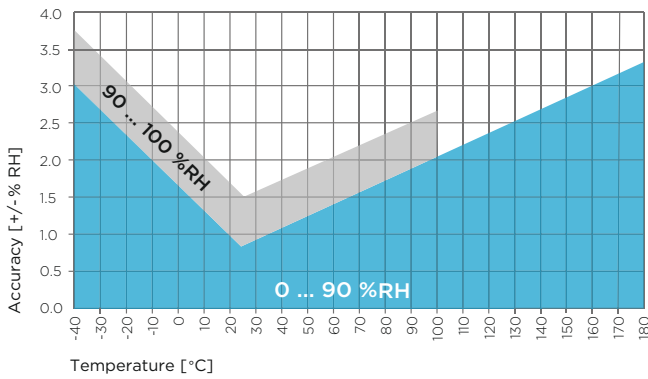

HMP4 Humidity Measurement Accuracy as a Function of Temperature (Including Non-Linearity and Repeatability)

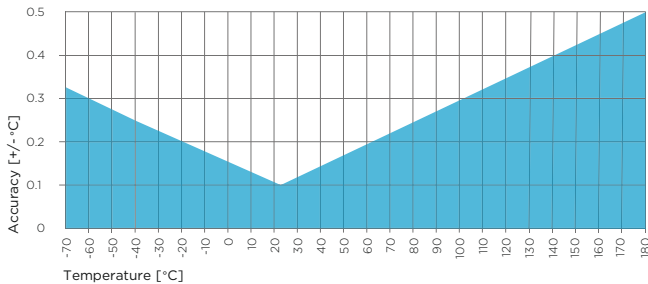

HMP4 Temperature Measurement Accuracy over Full Range (Including Non-Linearity and Repeatability)

Operating Environment

Operating temperature range for probe body	-40 ... +80 °C (-40 ... +176 °F)
Operating temperature range for probe head	-70 ... +180 °C (-94 ... +356 °F)
Operating environment	Suitable for outdoor use
IP rating	IP66
Electromagnetic compatibility	EN61326-1, industrial environment
Operational pressure	< 100 bar

Inputs and Outputs

Operating voltage	15 ... 30 VDC
Current consumption	10 mA typical, 500 mA max.
Digital output	RS-485, non-isolated
Default serial settings	19200 bps N 8 2
Protocols	Modbus RTU

Output Parameters

Relative humidity, temperature, dew point temperature, wet-bulb temperature, absolute humidity, mixing ratio, water concentration, water mass fraction, water vapor pressure, enthalpy

Mechanical Specifications

Probe fitting	M22x1.5 and NPT1/2" fittings included
Connector	M12/5
Weight	530 g (18.7 oz)
Materials	
Probe	AISI316
Probe body	AISI316
Cable jacket	FEP

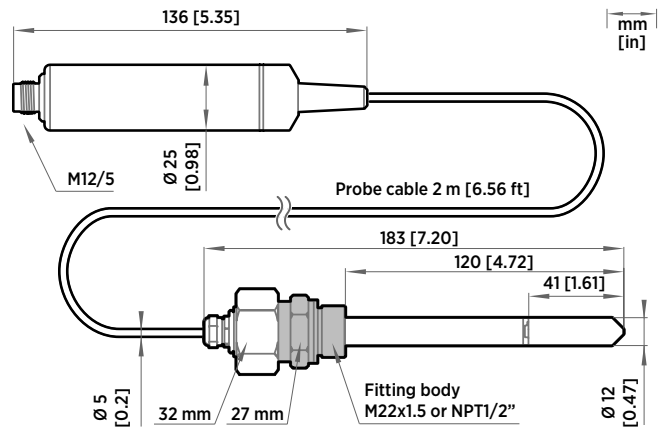

HMP4 Probe Dimensions

SI Traceable Calibration

Uncertainty of relative humidity calibration ($k = 2$)	±0.5 %RH (0 ... 40 %RH) ±0.8 %RH (40 ... 95 %RH)
Uncertainty of temperature calibration ($k = 2$)	±0.1 °C (±0.18 °F) at +23 °C (+73.4 °F)



HMP5 Relative Humidity and Temperature Probe

For High Temperatures

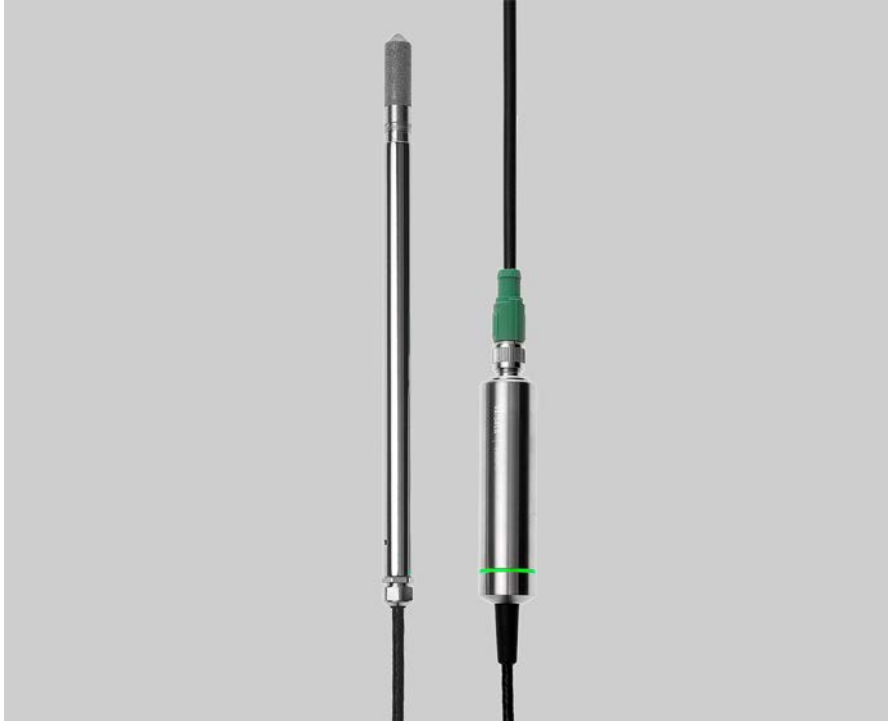

Features

- RH accuracy up to 0.8 %RH
- Temperature accuracy up to 0.1 °C (0.18 °F)
- Temperature measurement range -70 ... +180 °C (-94 ... +356 °F)
- Operating temperature range for probe body -40 ... +80 °C (-40 ... +176 °F)
- Sensor purge provides superior chemical resistance
- Modbus RTU over RS-485
- 250-mm (9.84 in) probe allows easy process installation through insulation
- Plug & play compatible with Indigo series of transmitters
- Traceable calibration certificate: 5 points for humidity, 1 point for temperature

Vaisala HUMICAP® Humidity and Temperature Probe HMP5 is designed for high-temperature applications such as baking ovens, pasta dryers, and industrial drying kilns, where measurement performance and chemical tolerance are essential.

Proven Vaisala HUMICAP® Performance

Vaisala is the original innovator of the thin-film capacitive humidity measurement technology, which has now become the industry standard in humidity measurement.

HUMICAP® technology results from Vaisala's 40-year experience in industrial humidity measurement, providing the best stability, fast response time, and low hysteresis in a wide range of applications.

Chemical Purge Minimizes Effects of Contaminants

In environments with high concentrations of chemicals and cleaning agents, the chemical purge option helps to maintain measurement accuracy between calibration intervals.

The chemical purge involves heating the sensor to remove harmful chemicals. The function can be initiated manually or programmed to occur at set intervals.

Flexible Connectivity

The probe is plug and play compatible with Vaisala Indigo series of transmitters, or it can be used as a standalone digital Modbus RTU transmitter over RS-485 serial bus. For easy-to-use access to field calibration, device analytics, and configuration functionality, the probe can be connected to Vaisala Insight software (for Windows® 7, 8.1 and 10: see www.vaisala.com/insight).

Vaisala Indigo Product Family

Indigo transmitters offer a variety of connectivity options through analog signals or digital outputs, configurable relays, and wireless (WLAN) configuration interface, providing a suitable solution for all industrial humidity measurements. The cable length between the probe and transmitter can be extended to up to 30 meters. For more information, see www.vaisala.com/indigo.

Technical Data

Measurement Performance

Relative Humidity

Sensor	HUMICAP R2 Composite
Measurement range	0 ... 100 %RH
Accuracy at +23 °C (+73.4 °F) ¹⁾	±0.8 %RH (0 ... 90 %RH)
T ₆₃ response time	15 s

Temperature

Sensor	Pt100 RTD Class F0.1 IEC 60751
Measurement range	-70 ... +180 °C (-94 ... +356 °F)
Accuracy at +23 °C (+73.4 °F) ¹⁾	±0.1 °C (±0.18 °F)

¹⁾ Defined against calibration reference

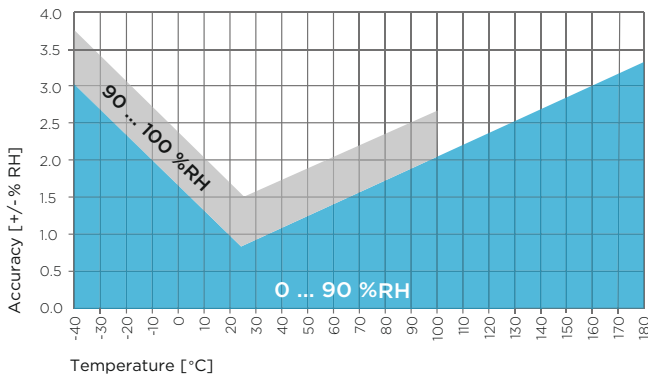

HMP5 Humidity Measurement Accuracy as a Function of Temperature (Including Non-Linearity and Repeatability)

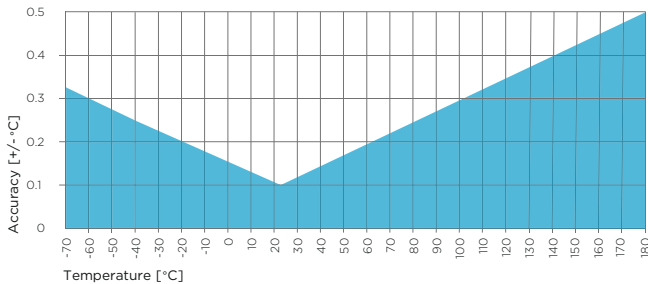

HMP5 Temperature Measurement Accuracy over Full Range (Including Non-Linearity and Repeatability)

Operating Environment

Operating temperature range for probe body	-40 ... +80 °C (-40 ... +176 °F)
Operating temperature range for probe head	-70 ... +180 °C (-94 ... +356 °F)
Operating environment	Suitable for outdoor use
IP rating	IP66
Electromagnetic compatibility	Complies with EMC standard EN61326-1, Electrical equipment for measurement, control and laboratory use - EMC requirements - Industrial environment

Inputs and Outputs

Operating voltage	15 ... 30 VDC
Current consumption	10 mA typical 500 mA max.
Digital output	RS-485, non-isolated
Default serial settings	19200 bps N 8 2
Protocols	Modbus RTU

Output Parameters

Relative humidity, temperature, dew point temperature, wet-bulb temperature, absolute humidity, mixing ratio, water concentration, water mass fraction, water vapor pressure, enthalpy

Mechanical Specifications

Connector	M12/5
Weight	436 g (15.37 oz)
Materials	
Probe	AISI316L
Probe body	AISI316L
Cable jacket	FEP

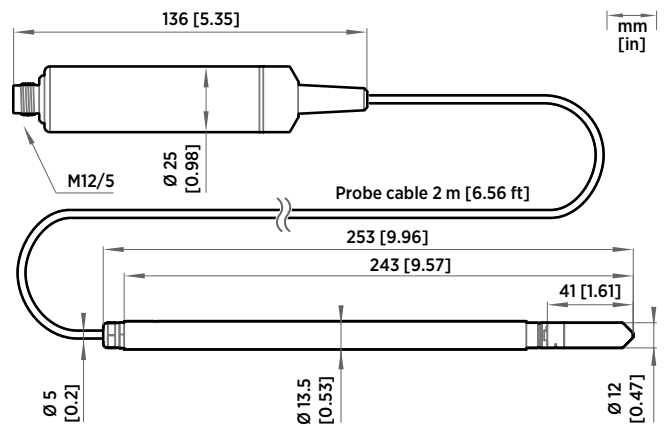

HMP5 Probe Dimensions

SI Traceable Calibration

Uncertainty of relative humidity calibration ($k = 2$)	±0.5 %RH (0 ... 40 %RH) ±0.8 %RH (40 ... 95 %RH)
Uncertainty of temperature calibration ($k = 2$)	±0.1 °C (±0.18 °F) at +23 °C (+73.4 °F)



Features

- RH accuracy up to 0.8 %RH
- Temperature accuracy up to 0.1 °C (0.18 °F)
- Temperature measurement range -70 ... +180 °C (-94 ... +356 °F)
- Vapor and pressure proof construction
- Probe and sensor warming functions minimize condensation on probe
- Sensor purge provides superior chemical resistance
- Modbus RTU over RS-485
- Plug & play compatible with Indigo series of transmitters
- Traceable calibration certificate: 5 points for humidity, 1 point for temperature

Vaisala HUMICAP® Humidity and Temperature Probe HMP7 is designed for applications that involve constant high humidity or rapid changes in humidity, such as drying and test chambers, combustion air, and other humidifiers and meteorological measurements, where measurement performance and chemical tolerance are essential.

Proven Vaisala HUMICAP® Performance

Vaisala is the original innovator of the thin-film capacitive humidity measurement technology, which has now become the industry standard in humidity measurement.

HUMICAP® technology results from Vaisala's 40-year experience in industrial humidity measurement, providing the best stability, fast response time, and low hysteresis in a wide range of applications.

Avoiding Condensation at Extreme Humidity

Probe heating functionality heats up not only the sensor, but the whole probe head. When probe temperature is heated above dew point temperature,

condensation on the probe can be avoided while measuring the dew point temperature of the process. By setting the temperature compensation value obtained, for example, with the TMP1 temperature probe, true relative humidity at process temperature can be measured while avoiding condensation by elevated probe temperature.

Vaisala Indigo Product Family

Indigo transmitters offer a variety of connectivity options through analog signals or digital outputs, configurable relays, and wireless (WLAN) configuration interface, providing a suitable solution for all industrial humidity measurements. The cable

length between the probe and transmitter can be extended to up to 30 meters. For more information, see www.vaisala.com/indigo.

Flexible Connectivity

The probe is plug and play compatible with Vaisala Indigo series of transmitters, or it can be used as a standalone digital Modbus RTU transmitter over RS-485 serial bus. For easy-to-use access to field calibration, device analytics, and configuration functionality, the probe can be connected to Vaisala Insight software (for Windows® 7, 8.1 and 10: see www.vaisala.com/insight).

Technical Data

Measurement Performance

Relative Humidity

Sensor	HUMICAP R2 Composite
Measurement range	0 ... 100 %RH
Accuracy at +23 °C (+73.4 °F) ¹⁾	±0.8 %RH (0 ... 90 %RH)
T ₆₃ response time	15 s

Temperature

Sensor	Pt100 RTD Class F0.1 IEC 60751
Measurement range	-70 ... +180 °C (-94 ... +356 °F)
Accuracy at +23 °C (+73.4 °F) ¹⁾	±0.1 °C (±0.18 °F)

¹⁾ Defined against calibration reference

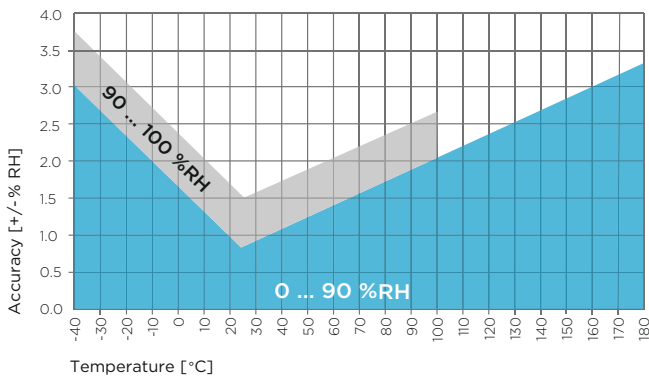

HMP7 Humidity Measurement Accuracy as Function of Temperature (Including Non-Linearity and Repeatability).

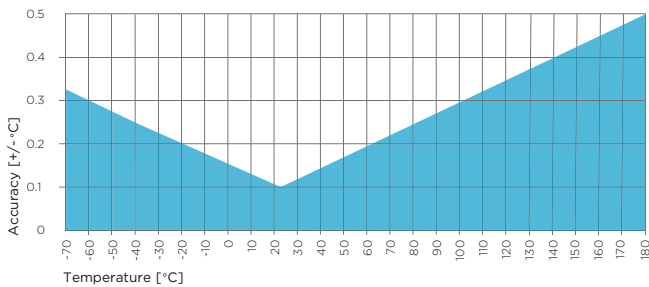

HMP7 Temperature Measurement Accuracy over Full Range (Including Non-Linearity and Repeatability)

Operating Environment

Operating temperature range for probe body	-40 ... +80 °C (-40 ... +176 °F)
Operating temperature range for probe head	-70 ... +180 °C (-94 ... +356 °F)
Operating environment	Suitable for outdoor use
IP rating	IP66
Electromagnetic compatibility	EN61326-1, Electrical equipment for measurement, control and laboratory use - EMC requirements - Industrial environment

Inputs and Outputs

Operating voltage	18 ... 30 VDC
Current consumption	10 mA typical 500 mA max.
Digital output	RS-485, non-isolated
Default serial settings	19200 bps N 8 2
Protocols	Modbus RTU

Output Parameters

Relative humidity, temperature, dew point temperature, wet-bulb temperature, absolute humidity, mixing ratio, water concentration, water mass fraction, water vapor pressure, enthalpy

Mechanical Specifications

Connector	M12/5
Weight	310 g (10.9 oz)
Materials	
Probe	AISI316L
Probe body	AISI316L
Cable jacket	FEP

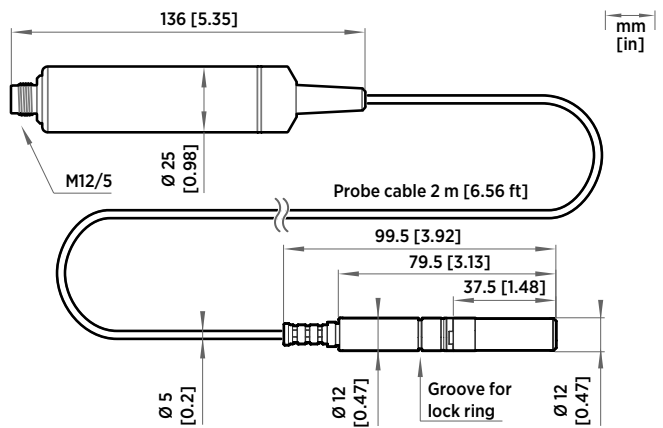

HMP7 Probe Dimensions

SI Traceable Calibration

Uncertainty of relative humidity calibration ($k = 2$)	±0.5 %RH (0 ... 40 %RH) ±0.8 %RH (40 ... 95 %RH)
Uncertainty of temperature calibration ($k = 2$)	±0.1 °C (±0.18 °F) at +23 °C (+73.4 °F)

HMP8 Relative Humidity and Temperature Probe

For Pressurized and Vacuum Processes

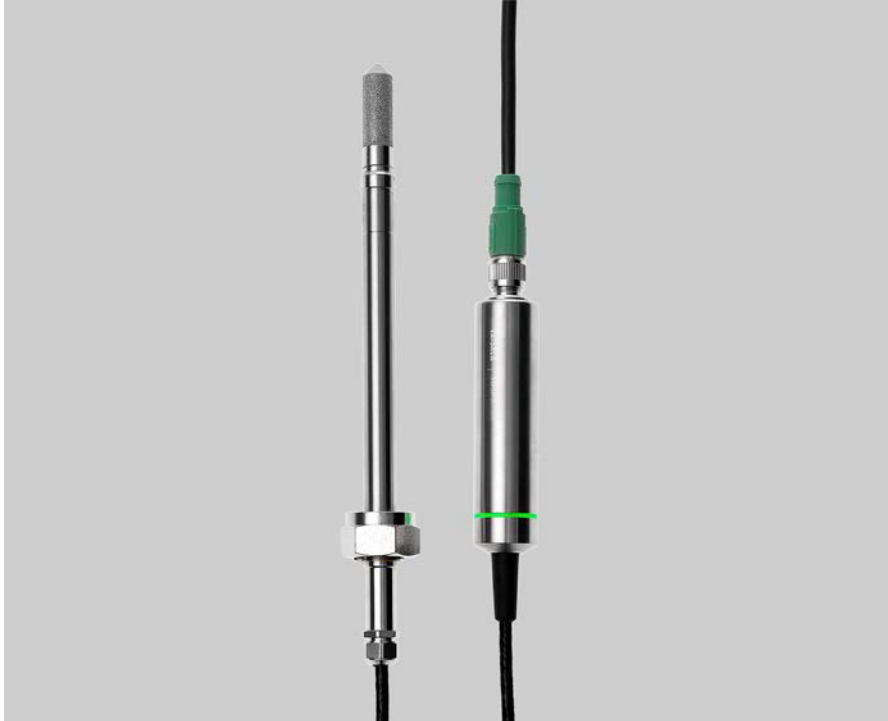

Features

- RH accuracy up to 0.8 %RH
- Temperature accuracy up to 0.1 °C (0.18 °F)
- Operating pressure 0 ... 4 MPa (0 ... 40 bar)
- Temperature measurement range -70 ... +180 °C (-94 ... +356 °F)
- Sensor purge provides superior chemical resistance
- Probe installation depth can be freely adjusted and probe can be hot-swapped from pressurized pipelines with an installation valve
- Modbus RTU over RS-485
- Plug & play compatible with Indigo series of transmitters
- Traceable calibration certificate: 5 points for humidity, 1 point for temperature

Vaisala HUMICAP® Humidity and Temperature Probe HMP8 is designed for pressurized applications in compressed air systems, refrigerant dryers, and other pressurized industrial applications, where easy insertion and removal of the probe and adjustable installation depth into the pipeline are needed.

Proven Vaisala HUMICAP® Performance

Vaisala is the original innovator of the thin-film capacitive humidity measurement technology, which has now become the industry standard in humidity measurement.

HUMICAP® technology results from Vaisala's 40-year experience in industrial humidity measurement, providing the best stability, fast response time, and low hysteresis in a wide range of applications.

Chemical Purge Minimizes Effects of Contaminants

In environments with high concentrations of chemicals and cleaning agents, the chemical purge option helps to maintain measurement accuracy between calibration intervals.

The chemical purge involves heating the sensor to remove harmful chemicals. The function can be initiated manually or programmed to occur at set intervals.

Flexible Connectivity

The probe is plug and play compatible with Vaisala Indigo series of transmitters, or it can be used as a standalone digital Modbus RTU transmitter over RS-485 serial bus. For easy-to-use access to field calibration, device analytics, and configuration functionality, the probe can be connected to Vaisala Insight™ Software (see www.vaisala.com/insight).

Vaisala Indigo Product Family

Indigo transmitters offer a variety of connectivity options through analog signals or digital outputs, configurable relays, and wireless (WLAN)

configuration interface, providing a suitable solution for all industrial humidity measurements. The cable length between the probe and transmitter can be extended to up to 30 meters. For more information, see www.vaisala.com/indigo.

Technical Data

Measurement Performance

Relative Humidity

Sensor	HUMICAP R2 Composite
Measurement range	0 ... 100 %RH
Accuracy at +23 °C (+73.4 °F) ¹⁾	±0.8 %RH (0 ... 90 %RH)
T ₆₃ response time	15 s

Temperature

Sensor	Pt100 RTD Class F0.1 IEC 60751
Measurement range	-70 ... +180 °C (-94 ... +356 °F)
Accuracy at +23 °C (+73.4 °F) ¹⁾	±0.1 °C (±0.18 °F)

¹⁾ Defined against calibration reference

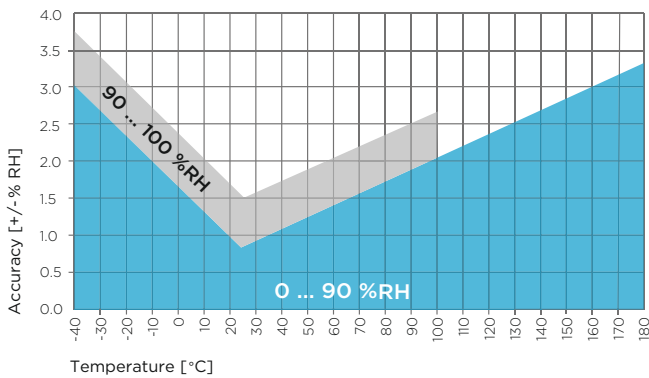

HMP8 Humidity Measurement Accuracy as a Function of Temperature (Including Non-Linearity and Repeatability)

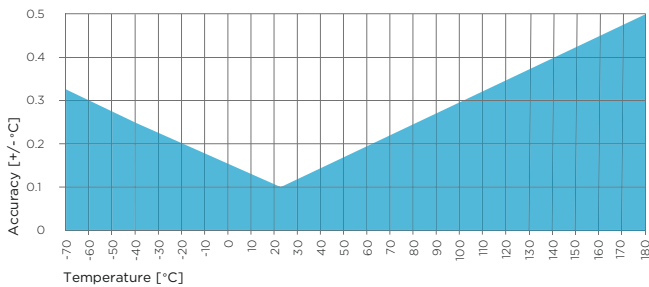

HMP8 Temperature Measurement Accuracy over Full Range (Including Non-Linearity and Repeatability)

Operating Environment

Operating temperature range for probe body	-40 ... +80 °C (-40 ... +176 °F)
Operating temperature range for probe head	-70 ... +180 °C (-94 ... +356 °F)
Operating environment	Suitable for outdoor use
IP rating	IP66
Electromagnetic compatibility	Complies with EMC standard EN61326-1, Electrical equipment for measurement, control and laboratory use - EMC requirements - Industrial environment
Operational pressure	< 40 bar

Inputs and Outputs

Operating voltage	15 ... 30 VDC
Current consumption	10 mA typical 500 mA max.
Digital output	RS-485, non-isolated
Default serial settings	19200 bps N 8 2
Protocols	Modbus RTU

Output Parameters

Relative humidity, temperature, dew point temperature, wet-bulb temperature, absolute humidity, mixing ratio, water concentration, water mass fraction, water vapor pressure, enthalpy

Mechanical Specifications

Probe fitting	ISO1/2" and NPT1/2" fittings included
Connector	M12/5
Weight	570 g (20.1 oz)
Materials	
Probe	AISI316L
Probe body	AISI316L
Cable jacket	FEP

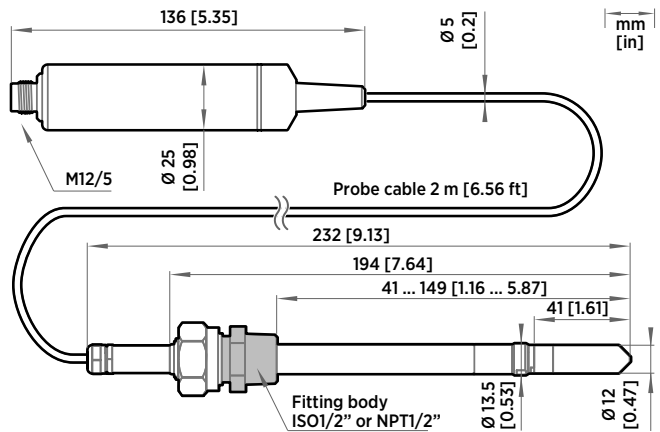

HMP8 Probe Dimensions

SI Traceable Calibration

Uncertainty of relative humidity calibration ($k = 2$)	±0.5 %RH (0 ... 40 %RH) ±0.8 %RH (40 ... 95 %RH)
Uncertainty of temperature calibration ($k = 2$)	±0.1 °C (±0.18 °F) at +23 °C (+73.4 °F)



Features

- Temperature accuracy up to 0.1 °C (0.18 °F)
- Temperature measurement range -70 ... +180 °C (-94 ... +356 °F)
- Modbus RTU over RS-485
- Plug & play compatible with Indigo series of transmitters
- Traceable 2-point calibration certificate (calibration points at +20 and +70 °C (+68 and +158 °F))

Vaisala Temperature Probe TMP1 is designed for demanding temperature measurements in industrial applications such as pharmaceutical industry and calibration laboratories, where accuracy and robustness are essential.

Flexible Connectivity

The probe is plug and play compatible with Vaisala Indigo series of transmitters, or it can be used as a standalone digital Modbus RTU transmitter over RS-485 serial bus. For easy-to-use access to field calibration, device analytics, and configuration functionality, the probe can be connected to Vaisala Insight software (for Windows® 7, 8.1 and 10: see www.vaisala.com/insight).

Vaisala Indigo Product Family

Indigo transmitters offer a variety of connectivity options through analog signals or digital outputs, configurable relays, and wireless (WLAN)

configuration interface, providing a suitable solution for all industrial humidity measurements. The cable length between the probe and transmitter can be extended to up to 30 meters. For more information, see www.vaisala.com/indigo.

Relative Humidity Measurements in High Humidities

When the TMP1 probe is connected to a control system in parallel with HMP7 Relative Humidity and Temperature Probe, it is possible to have relative humidity measurement in actual process temperature while using probe heating in

the relative humidity probe. Probe heating helps to avoid condensation in situations where the dew point temperature of the process is close to the ambient temperature.

When the humidity probe is heated above dew point temperature, condensation can be avoided and the relative humidity in the actual process temperature can be back-calculated based on the true process temperature measurement received from TMP1.

Technical Data

Measurement Performance

Sensor	Pt100 RTD Class F0.1 IEC 60751
Measurement range	-70 ... +180 °C (-94 ... +356 °F)
Accuracy at +23 °C (+73.4 °F) ¹⁾	±0.1 °C (±0.18 °F)

1) Defined against calibration reference

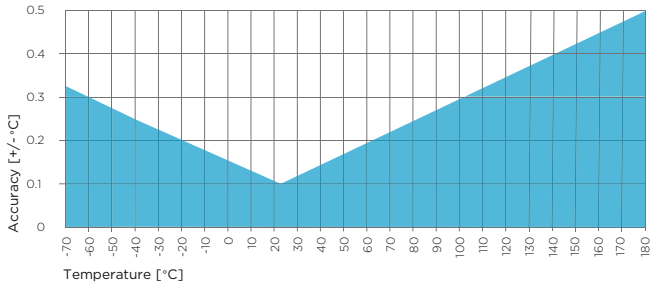

TMP1 Temperature Measurement Accuracy over Full Range (Including Non-Linearity and Repeatability)

SI Traceable Calibration

Uncertainty of temperature calibration ±0.1 °C (±0.18 °F) at +23 °C (+73.4 °F) (k = 2)

Operating Environment

Operating temperature range for probe body	-40 ... +80 °C (-40 ... +176 °F)
Operating temperature range for probe head	-70 ... +180 °C (-94 ... +356 °F)
Operating environment	Suitable for outdoor use
IP rating	IP66
Electromagnetic compatibility	Complies with EMC standard EN61326-1, Industrial Environment

Inputs and Outputs

Operating voltage	15 ... 30 VDC
Current consumption	10 mA typical
Digital output	RS-485, non-isolated
Default serial settings	19200 bps N 8 2
Protocols	Modbus RTU
Output parameters	Temperature, water vapor saturation pressure

Mechanical Specifications

Connector	M12/5
Weight	224 g (7.9 oz)
Materials	
Probe	AISI316L
Probe body	AISI316L
Cable jacket	FEP

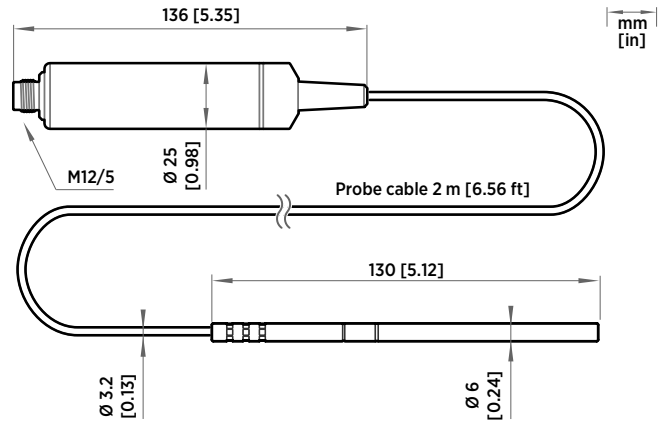

TMP1 Probe Dimensions



HMT330 Series Humidity and Temperature Transmitters

For Demanding Humidity Measurement



Features

- Full 0 ... 100 %RH measurement, temperature range up to +180 °C (+356 °F) depending on model
- Pressure tolerance up to 100 bar depending on model
- 4th generation Vaisala HUMICAP® sensor for superior accuracy and stability
- Corrosion-resistant IP65/IP66 housing
- Excellent performance in harsh conditions; good chemical tolerance
- Traceable calibration for measurement and analog outputs (certificates included)
- 10-year warranty when annually calibrated at the Vaisala Service Center

Vaisala HMT330 Series HUMICAP® Humidity and Temperature Transmitters are designed for demanding industrial applications where stable measurements and extensive customization are essential. With multiple options to choose from, the instrument can be tailored to meet the specific needs of each individual application and is pre-configured for each delivery.

Proven Vaisala HUMICAP Performance

The HMT330 series incorporates Vaisala's 40 years of experience in industrial humidity measurement. The updated fourth-generation HUMICAP® sensor provides accurate and stable measurement even in environments with high humidity or chemical contaminants.

Wide Range of Installation Options

The wide variety of measurement probes, several installation accessories, and universal mains and DC power options make the instruments easy to install in various locations and kinds of environment; walls, poles, pipelines, and

ducts, for example. The input/output cable can be fed through the back of the transmitter, which is a useful feature, especially for cleanroom installations.

The HMT330 series includes six models:

- HMT331 for wall-mounted applications
- HMT333 for ducts and tight spaces
- HMT334 for high-pressure and vacuum applications
- HMT335 for high-temperature applications
- HMT337 for high-humidity applications
- HMT338 for pressurized pipelines

With multiple options to choose from, including local display, the HMT330 series can be tailored to meet the specific needs of each individual

application and is preconfigured for each delivery. Also the HUMICAP® sensor itself can be selected according to specific measurement application needs.

Connectivity

- RS-232/485/422 LAN
- Modbus protocol support (RTU/TCP)
- Optional graphical display and keypad for convenient operation
- Multilingual user interface
- Compatible with Vaisala viewLinc software

HMT330 Series Humidity and Temperature Transmitters

Graphical Display of Measurement Data and Trends for Convenient Operation

The HMT330 series features an optional numerical and graphical display with a multilingual menu and keypad. It allows users to easily monitor operational data, measurement trends, and access measurement history of up to 4 years.

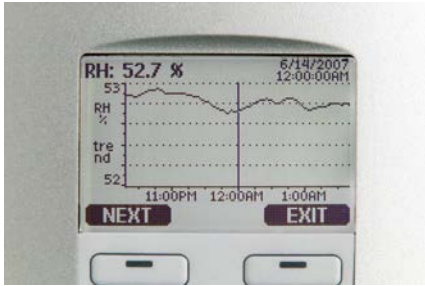

The display shows measurement trends and over four years of real-time measurement history.

The display alarm allows any measured parameter to be tracked, with freely configurable low and high limits.

Versatile Outputs and Data Collection

The HMT330 can support up to three analog outputs; an isolated galvanic power supply and up to four relay outputs are also available.

For serial interface the USB service cable, RS-232, and RS-485/422 can be used.

HMT330 is also capable of applying the Modbus communication protocol and, together with an appropriate connection option, provides either Modbus RTU (RS-485) or Modbus TCP/IP (Ethernet) communication.

The data logger, with real-time clock and battery backup, guarantees reliable logging of measurement data for over four years. The recorded data can be viewed on the local display or transferred to a PC with Microsoft Windows® software. The transmitter can also be connected to a network with an optional LAN interface, which enables an Ethernet connection. A USB service cable makes it easy to connect the HMT330 to a PC via the service port.

Flexible Calibration

The HMT330 instruments are calibrated at five humidity points at the factory and come with a calibration certificate that meets all the relevant traceability and compliance requirements.

A quick, one-point field calibration can be performed with the handheld HM70 meter. A two-point field calibration can be performed, for example, with the

HMK15 salt bath calibrator in a controlled environment. The transmitter can also be sent to Vaisala for recalibration, and accredited ISO/IEC17025 calibrations and special calibrations are available.

Chemical Purge Minimizes Effects of Contaminant

In environments with high concentrations of chemicals and cleaning agents, the chemical purge option helps to maintain measurement accuracy between calibration intervals.

The chemical purge involves heating the sensor to remove harmful chemicals. The function can be initiated manually or programmed to occur at set intervals.

	HMT331	HMT333	HMT334	HMT335	HMT337	HMT338
For	Measurement within rooms	General purposes	High pressure and vacuum applications	High temperatures	High humidity applications	Pressurized pipelines
Temperature Measurement Range	-40 ... +60 °C (-40 ... +140 °F)	-40 ... +80 °C (-40 ... +176 °F) or -40 ... +120 °C (-40 ... +248 °F)	-70 ... +180 °C (-94 ... +356 °F)	-70 ... +180 °C (-94 ... +356 °F)	-70 ... +180 °C (-94 ... +356 °F)	-70 ... +180 °C (-94 ... +356 °F)
Operating Pressure			0 ... 10 MPa (0 ... 100 bar)		0 ... 1 MPa (0 ... 10 bar)	0 ... 4MPa (0 ... 40 bar)

HMT330 Series Technical Data

Measurement Performance

Relative Humidity

Measurement range	0 ... 100 %RH
Accuracy (including non-linearity, hysteresis, and repeatability)	
at +15 ... +25 °C (59 ... +77 °F)	±1 %RH (0 ... 90 %) ±1.7 %RH (90 ... 100 %RH)
at -20 ... +40 °C (-4 ... +104 °F)	±(1.0 + 0.008 x reading) %RH
at -40 ... +180 °C (-40 ... +356 °F)	±(1.5 + 0.015 x reading) %RH
Factory calibration uncertainty (+20 °C)	±0.6 %RH (0 ... 40 %RH) ±1.0 %RH (40 ... 97 %RH) (Defined as ±2 standard deviation limits. Small variations possible; see also calibration certificate.)
Response time (90%) at +20 °C (+68 °F) in still air / in 0.1 m/s air flow	8 s / 17 s with grid filter ¹⁾ 20 s / 50 s with grid + steel netting filter ¹⁾ 40 s / 60 s with sintered filter ¹⁾

Temperature

Accuracy at +20 °C (+68 °F)	± 0.2 °C (± 0.36 °F)
Accuracy over temperature range (measurement range depends on model)	

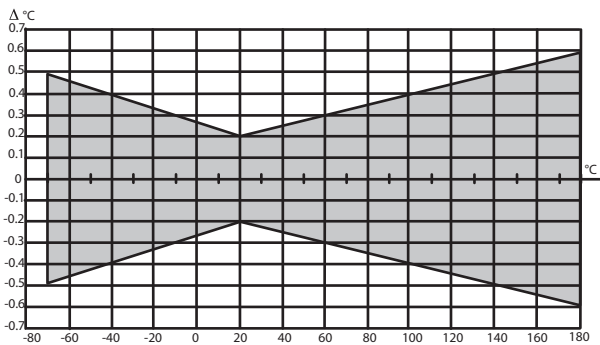

Temperature sensor Pt100 RTD Class F0.1 IEC 60751

Other Available Variables (Model-Dependent)

dew point temperature, mixing ratio, absolute humidity, wet bulb temperature, enthalpy, water vapor pressure

¹⁾ With HUMICAP 180R or 180RC or 180VC sensor

Operating Environment

Operating Temperature

for probe	same as measurement range
for transmitter body	-40 ... +60 °C (-40 ... 140 °F)
with display	0 ... +60 °C (32 ... 140 °F)
Storage temperature	-55 ... +80 °C (-67 ... 176 °F)
EMC compliance	EN61326-1, Industrial Environment Note: Transmitter with display test impedance of 40 Ω is used in IEC61000-4-5 (Surge immunity)

Mechanical Specifications

Cable bushing	M20 x 1.5 for cable diameter 8 ... 11 mm / 0.31 ... 0.43"
Conduit fitting	1/2" NPT
User cable connector (optional)	M12 series 8-pin (male)
option 1	female plug with 5 m (16.4 ft.) black cable
option 2	female plug with screw terminals
Probe Cable Diameter	
HMT333 (+80 °C)	6.0 mm
other probes	5.5 mm
Standard probe cable lengths	2 m, 5 m or 10 m (Additional lengths available, see order forms for details)
Housing material	G-AISI 10 Mg (DIN1725)
IP rating	IP66 IP65 (NEMA4X) with local display
Weight	1.0 - 3.0 kgs depending on selected probe, cable and modules

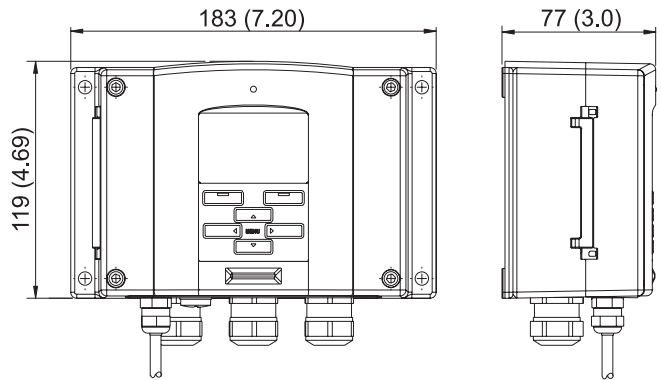

Dimensions in mm (inches)

Inputs and Outputs

Operating Voltage	10 ... 35 VDC, 24 VAC ±20%
with optional power supply module	100 ... 240 VAC, 50/60 HZ
Power Consumption at +20 °C (U_{in} 24 VDC)	
RS-232	max. 25 mA
U _{out} 2 x 0 ... 1 V/0 ... 5 V/0 ... 10 V	max. 25 mA
I _{out} 2 x 0 ... 20 mA	max. 60 mA
display and backlight	+ 20 mA
during chemical purge	max. 110 mA
during probe heating (HMT337)	+ 120 mA
Analog Outputs (2 standard, 3rd optional)	
current output	0 ... 20 mA, 4 ... 20 mA
voltage output	0... 1 V, 0... 5 V, 0... 10 V
Accuracy of analog outputs at +20 °C	±0.05% full scale
Temperature dependence of the analog outputs	±0.005%/°C full scale
External loads:	
current outputs	R _L < 500 Ω
0 ... 1 V output	R _L > 2 kΩ
0 ... 5 V and 0 ... 10 V outputs	R _L > 10 kΩ
Max. Wire Size	0.5 mm ² (AWG 20)
	stranded wires recommended
Digital outputs	RS-232, RS-485 (optional)
Protocols	ASCII commands, Modbus RTU
Service Connection	RS-232, USB
Relay Outputs (Optional)	0.5 A, 250 VAC
Ethernet Interface (Optional)	
Supported standards	10BASE-T, 100BASE-TX
Connector	8P8C (RJ45)
IPv4 address assignment	DHCP (automatic), static
Protocols	Telnet, Modbus TCP/IP
Optional Data Logger with Real-Time Clock	
Logged parameters	max. four with trend/min/max values
Logging interval	10 sec. (fixed)
Max. logging period with max. temporal resolution	4 years, 5 months
Logged points	13.7 million points per parameter
Battery lifetime	min. 5 years
Display	LCD with backlight, graphical trend display of any parameter
Menu languages	English, Chinese, Finnish, French, German, Japanese, Russian, Spanish, Swedish

Mounting Options

Mounting with Wall Mounting Kit (not mandatory for wall installations)

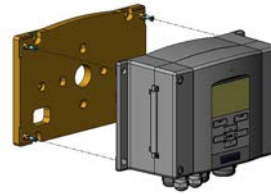

Mounting with DIN Rail Installation Kit

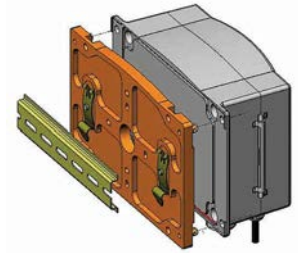

Pole Installation with Installation Kit for Pole or Pipeline



Mounting Rain Shield with Installation Kit

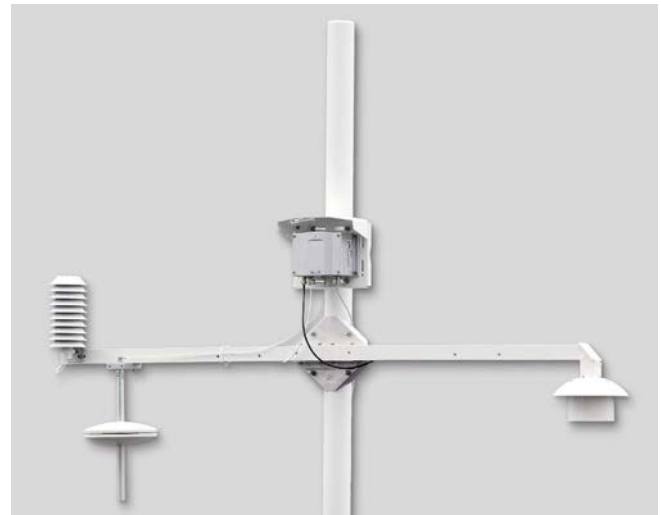

Vaisala Meteorological Installation Kit HMT330MIK enables HMT337 to be installed outdoors to obtain reliable measurements for meteorological purposes

HMT331 Humidity and Temperature Transmitter for Demanding Wall-Mounted Applications



Typical Applications

- Cleanrooms
- Pharmaceutical processes
- Swimming halls
- Data centers
- Archives

Vaisala HUMICAP® Humidity and Temperature Transmitter HMT331 is a high-quality wall-mounted transmitter for demanding HVAC and condition-monitoring applications.

Technical Data

Temperature measurement range -40 ... +60 °C (-40 ... +140 °F)

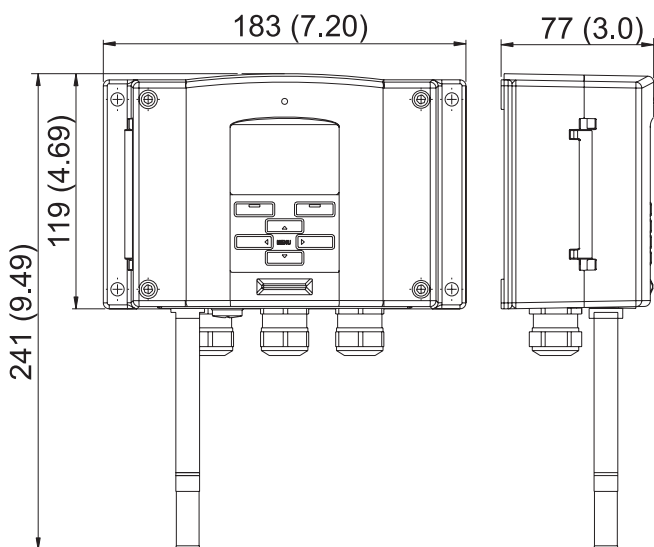

Dimensions in mm (inches)



HMT331 with short cable probe

Accessories

USB service port cable with PC software	219916
Connection cable for HM70	211339
Wall-mounting plate (plastic)	214829
Pole installation kit with rain shield	215109
DIN rail installation set	215094
PPS plastic grid filter with stainless steel net	DRW010281SP
Stainless steel sintered filter	HM47280SP

HMT333 Humidity and Temperature Transmitter for Ducts and Tight Spaces



Typical Applications

- Cleanrooms
- Industrial HVAC systems
- Environmental chambers
- Processes with moderate temperature and humidity

Technical Data

Temperature measurement range -40 ... +80 °C (-40 ... +176 °F) or -40 ... +120 °C (-40 ... +248 °F)

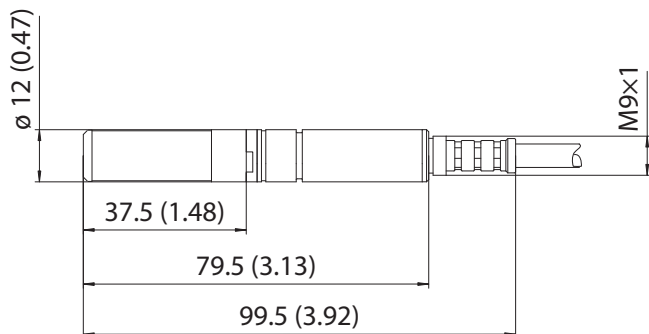

Dimensions in mm (inches)

Accessories

Duct installation kit	210697
Cable gland with split seal	HMP247CG
USB service port cable with PC software	219916
Connection cable for HM70	211339
Wall-mounting plate (plastic)	214829
Pole installation kit with rain shield	215109
Solar radiation shield	DTR502B
DIN rail installation set	215094
PPS plastic grid filter with stainless steel net	DRW010281SP
PPS plastic grid filter	DRW010276SP
Stainless steel sintered filter	HM47280SP

Vaisala HUMICAP® Humidity and Temperature Transmitter HMT333 is a versatile instrument for applications where a small remote probe is needed, for example in demanding HVAC applications. Its small thermal mass enables rapid response to temperature changes.

Flexible Installation

To install the probe in ducts, channels, and through walls, an installation kit is available with a stainless steel flange, lead-through piece, and steel support bar.

HMT333 has two probe cable options – a flexible rubber cable that withstands temperatures of up to +80 °C, and a durable FEP cable that withstands temperatures of up to +120 °C. Both cable options are available in lengths of 2, 5, and 10 meters. Additionally, flexible rubber cable (+80 °C) is available in 20-meter lengths.

For outdoor environments, the DTR502B solar radiation shield provides protection for the probe. The shield can be installed on a pole, beam, or flat surface.

Duct installation kit for HMT333. The flange allows easy adjustment of probe installation depth.

Installation flange dimensions in mm (inches)

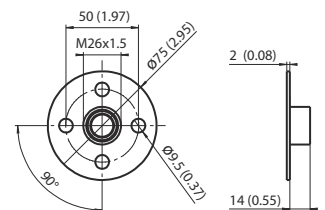

HMT334 Humidity and Temperature Transmitter for High Pressure and Vacuum Applications



Typical Applications

- Test chambers
- High-pressure and vacuum processes

Vaisala HUMICAP® Humidity and Temperature Transmitter HMT334 is designed for humidity measurement in pressurized spaces or vacuum chambers.

Every probe is tested for gas and vacuum-tight installation.

Technical Data

Temperature measurement range	-70 ... +180 °C (-94 ... +356 °F)
Operating pressure	0 ... 10 MPa (0 ... 100 bar)

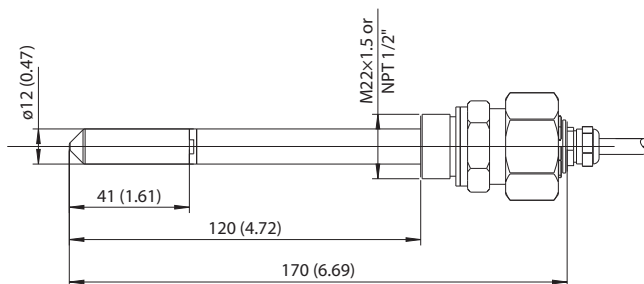

Dimensions in mm (inches)

Accessories

Fitting body NPT 1/2"	17225SP
USB service port cable with PC software	219916
Connection cable for HM70	211339
Wall-mounting plate (plastic)	214829
Pole installation kit with rain shield	215109
DIN rail installation set	215094
PPS plastic grid filter with stainless steel net	DRW010281SP
PPS plastic grid filter	DRW010276SP
Stainless steel sintered filter	HM47280SP
Stainless steel grid filter	HM47453SP
Fitting body ISO M22 x 1.5	17223SP

HMT335 Humidity and Temperature Transmitter for High Temperatures



Typical Applications

- Hot drying processes
- Food processes, e.g. baking ovens

Robust Probe Ideal for High Flow Rates

The Vaisala HUMICAP® Humidity and Temperature Transmitter HMT335 has a long stainless steel probe designed for high temperatures.

With high tolerance for mechanical stress and high flow rates, HMT335 is ideal for duct measurements. The stainless steel installation flange allows easy adjustment of the probe's installation depth. Long, robust probe allows easy installation through insulation in ovens and similar applications.

Technical Data

Temperature measurement range -70 ... +180 °C (-94 ... +356 °F)

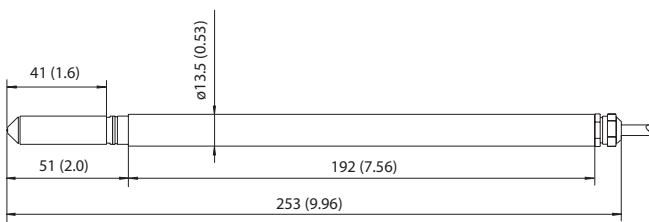

Dimensions in mm (inches)

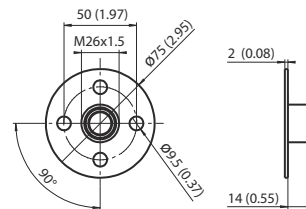

Installation flange dimensions in mm (inches)

Accessories

Mounting flange	210696
USB service port cable with PC software	219916
Connection cable for HM70	211339
Wall-mounting plate (plastic)	214829
Pole installation kit with rain shield	215109
DIN rail installation set	215094
PPS plastic grid filter with stainless steel net	DRW010281SP
PPS plastic grid filter	DRW010276SP
Stainless steel sintered filter	HM47280SP
Stainless steel grid filter	HM47453SP



Flange installation kit for HMT335

HMT337 Humidity and Temperature Transmitter for High Humidity Applications



Typical Applications

- Professional meteorology
- Intake air monitoring of engines and gas turbines
- Timber drying kilns

HMT337 Configurations

Vaisala HUMICAP® Humidity and Temperature Transmitter HMT337 is ideal for the most demanding process and meteorological measurements in high-humidity condensing environments.

HMT337 is delivered in one of three configurations:

1. Basic HMT337, with a non-warmed probe for applications where humidity levels are not constantly near condensation

2. HMT337 with a warmed probe, for dew point temperature measurement under constant near-condensing conditions
3. HMT337 with a warmed probe and an additional temperature sensor, for relative humidity measurement under constant near-condensing conditions

True Humidity Readings in Condensation Conditions

Vaisala's unique warmed probe provides fast and reliable measurement in environments where humidity is near saturation. The heating prevents condensation from forming on the sensor.

As the probe is heated, the relative humidity level inside it stays below the ambient level. With accurate temperature measurement, the ambient dew point temperature can be calculated precisely.

If the relative humidity value is needed, an optional temperature sensor is used (configuration option 3). The measured ambient temperature provides the compensation for calculating relative humidity and other temperature-dependent humidity parameters.

Installation Options

A pressure and vapor tight installation up to 10 bars through a process wall can be achieved by sealing with Swagelok® fittings from the probe, or sealing from the cable with a gland. The optional HMT330MIK Installation Kit is available for outdoor installations; duct installation kits are also available.

Technical Data

Temperature measurement range -70 ... +180 °C (-94 ... +356 °F)

Accessories

Cable gland for probe cable	HMP247CG
Duct installation kit (RH probe) ¹⁾	210697
Duct installation kit (T probe) ¹⁾	215003
Swagelok fittings (NPT and ISO) for both RH and T probes (up to 10 bar)	
Solar radiation shield	DTR502B
Meteorological installation kit	HMT330MIK
USB service port cable with PC software	219916
Connection cable for HM70	211339
Wall-mounting plate (plastic)	214829
Pole installation kit with rain shield	215109
DIN rail installation set	215094
Warmed probe accessory	HMT330WPA
PPS plastic grid filter with stainless steel net	DRW010281SP
PPS plastic grid filter	DRW010276SP
Stainless steel sintered filter	HM4728OSP
Stainless steel grid filter	HM47453SP

For more installation accessories, check the order form.

¹⁾ For an image of the duct installation kit, see HMT333 page.

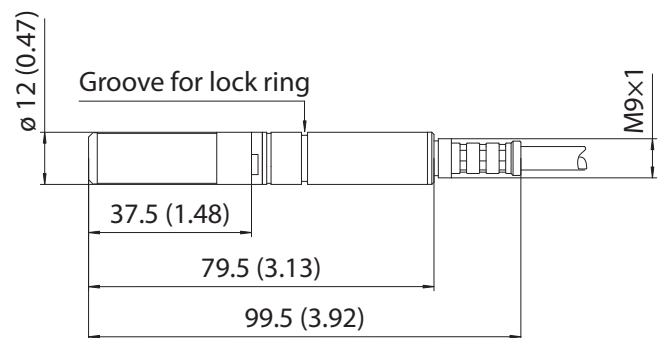

HMT337 RH Dimensions in mm (inches)

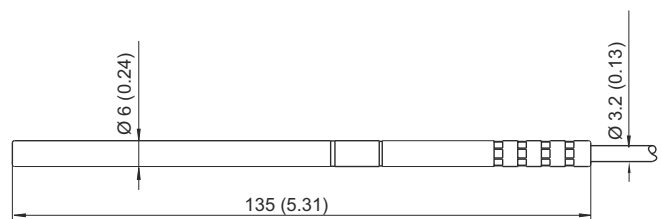

HMT337 T Dimensions in mm (inches)

HMT338 Humidity and Temperature Transmitter for Pressurized Pipelines



Typical Applications

- Process lines
- Environmental chambers
- Vacuum-drying processes
- Compressed air lines with refrigerant dryers

Vaisala HUMICAP® Humidity and Temperature Transmitter HMT338 is ideal for installations in pressurized processes where the probe needs to be removed while the process is running.

Insert or Remove the Probe while the Process is Running

With “hot tapping”, the probe is inserted directly into the process while it is running, without the need for venting or lowering the process pressure. The probe is tightened to a ball-valve assembly fixed to the process pipe or wall. The adjustable hex nut is hand-tightened to hold the probe in place temporarily.

The probe is then pushed down to the appropriate depth. The hex nut is then tightened with a wrench to lock the probe in place. Hot tapping is possible in pressures up to 10 bar.

Technical Data

Temperature measurement range	-70 ... +180 °C (-94 ... +356 °F)
Operating pressure	0 ... 4MPa (0 ... 40 bar)

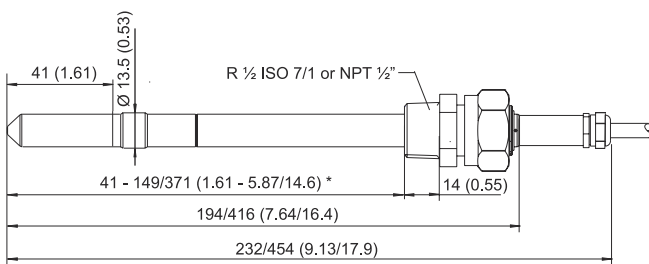

Lengths for standard / optional probes
* freely user-adjustable length

Dimensions in mm (inches)

Accessories

Ball-valve set	BALLVALVE-1
Pressure fitting ISO 1/2 to NPT 1/2	210662
USB service port cable with PC software	219916
Connection cable for HM70	211339
Wall-mounting plate (plastic)	214829
Pole installation kit with rain shield	215109
DIN rail installation set	215094
PPS plastic grid filter with stainless steel net	DRW010281SP
PPS plastic grid filter	DRW010276SP
Stainless steel sintered filter	HM47280SP
Stainless steel grid filter	HM47453SP





HMT360 Series Intrinsically Safe Humidity and Temperature Transmitters

For Operation in up to Zone 0 / 20



Features

- Measures humidity and temperature, outputs also dew point, mixing ratio, absolute humidity and wet bulb temperature
- Intrinsically safe
- Vaisala HUMICAP® Sensor features high accuracy, excellent long-term stability, and negligible hysteresis
- Six probe options
- Traceable calibration (certificate included)



Vaisala HUMICAP® Humidity and Temperature Transmitter Series HMT360 are the ideal solution for measuring humidity in hazardous areas. They operate safely and reliably even in the most hazardous classifications, such as zone 0. The HMT360 transmitters' proven performance and technology conform with rigorous international standards.

Operating Conditions

- Safe operation with the entire transmitter in hazardous areas: Division 1 and 2 (USA, Canada), Categories 1G / Zone 0 and 1D / Zone 20 with protection cover (EU)
- Designed for harsh conditions
- Temperature range between -70 ... +180 °C (-94 ... +356 °F) depending on the probe option

Intrinsically Safe

The entire HMT360 transmitter can be installed directly in explosive areas. It can withstand continuous exposure to potentially explosive environments that contain flammable gases or dust.

Customized Configuration

Due to the options and accessories, the HMT360 series is truly flexible.

Customers may specify the transmitter configuration when ordering the instrument. However, changes in configuration can also easily be made in the field.

Interchangeable Probes

HMT360 offers six probe options for various applications:

- HMT361 - wall mount
- HMT363 - confined spaces
- HMT364 - pressurized spaces
- HMT365 - high temperature
- HMT367 - high humidity
- HMT368 - pressurized pipelines

The interchangeable probes enable fast and easy removal or re-installation when required. Calibration, for example, is easy to perform due to the modular structure. All calibration coefficients are included in

the probe unit itself, which means that probes can be switched between transmitter bodies without losing the accuracy.

Optimized Sensors

In addition to the standard Vaisala HUMICAP® Sensor, an application-specific, very chemically durable sensor is also available.

Long-term Solution

The HMT360 transmitters are an investment: their rugged design, combined with trouble-free operation, ensure a long-term solution for monitoring humidity and dew point in explosive environments.

Customized calibration and maintenance contracts for the HMT360 series are available on request.

Interchangeable Probes for HMT360 Intrinsically Safe Humidity and Temperature Transmitter

HMT361 for Wall Mounting

Temperature range	-40 ... +60 °C (-40 ... +140 °F)
Probe diameter	12 mm (0.47 in)



The HMT361 probe in this picture has a stainless steel netting filter.

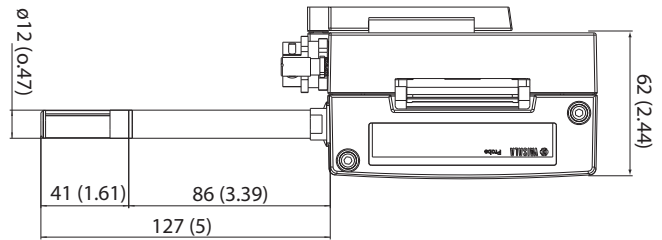

Dimensions in mm (inches)

HMT363 for Confined Spaces

Temperature range with teflon cable	-40 ... +120 °C (-40 ... +248 °F)
Temperature range with rubber cable	-40 ... +80 °C (-40 ... +176 °F)
Probe cable length	2, 5 or 10 meters (6 ft 7 in, 16 ft 5 in, 32 ft 10 in)
Probe diameter	12 mm (0.47 in)

Installation

Duct installation kit	210697
Cable gland M20x1.5 with splitting seal	HMP247CG
Swagelok for 12mm probe, 1/2" NPT thread	SWG12NPT12



The HMT363 probe is small and fits into tight spaces. This one is connected with a teflon cable.

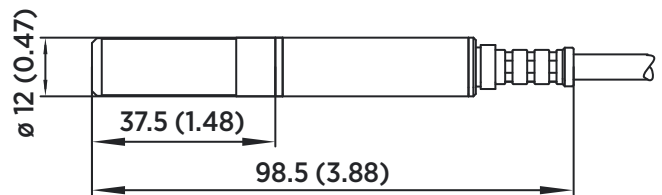

Dimensions in mm (inches)

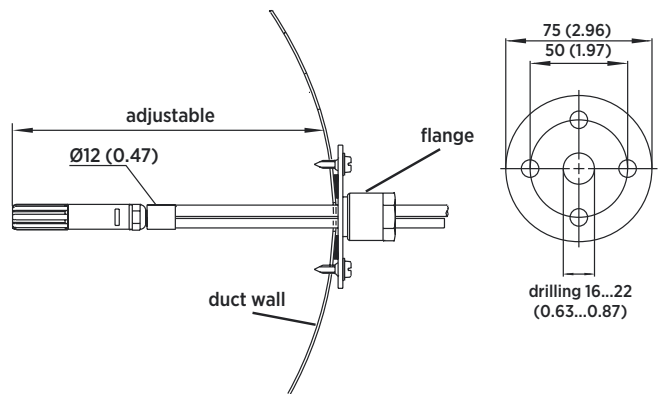

Left: Installation kit for duct mounting. Right: Installation flange. Aluminum or stainless steel.

HMT364 for High Pressure

Temperature range	-70 ... +180 °C (-94 ... +356 °F)
Pressure range	0 ... 10 MPa
Probe cable length	2, 5 or 10 meters (6 ft 7 in, 16 ft 5 in, 32 ft 10 in)
Probe diameter	12 mm (0.47 in)
Fitting body M22x1.5	17223
Fitting body NPT1/2	17225



The HMT364 probe is designed for measurement in pressurized spaces or vacuum chambers.

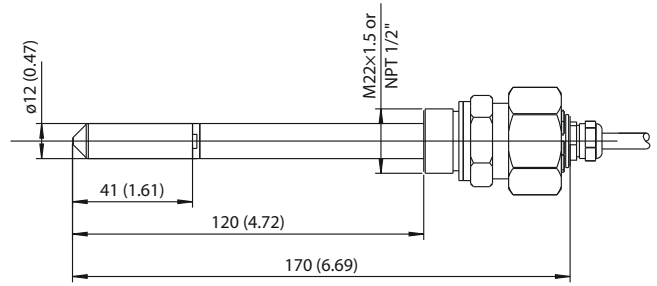

Dimensions in mm (inches)

HMT365 for High Temperature

Temperature range	-70 ... +180 °C (-94 ... +356 °F)
Probe cable length	2, 5 or 10 meters (6 ft 7 in, 16 ft 5 in, 32 ft 10 in)
Probe diameter	13.5 mm (0.53 in)
Installation	
Mounting flange	210696
Cable gland M20x1.5 with splitting seal	HMP247CG

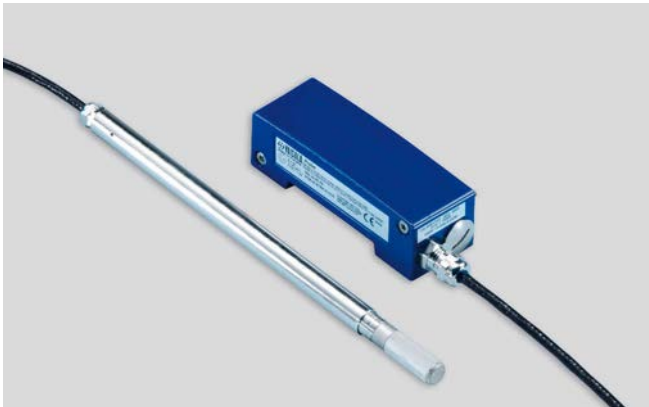

The HMT365 probe is designed for high temperature environments.

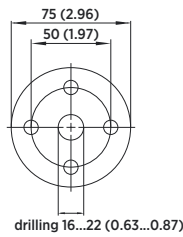
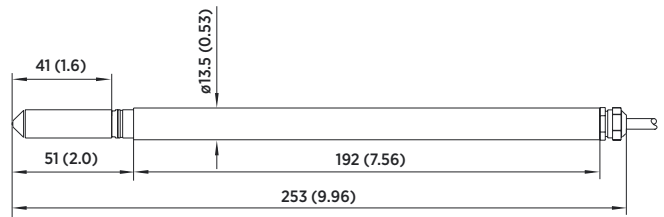

HMT365 probe and stainless steel installation flange. Dimensions in mm (inches).

HMT367 for High Humidities

Temperature range	-70 ... +180 °C (-94 ... +356 °F)
Probe cable length	2, 5 or 10 meters (6 ft 7 in, 16 ft 5 in, 32 ft 10 in)
Probe diameter	12 mm (0.47 in)
Installation	
Duct installation kit	210697
Cable gland M20x1.5 with splitting seal	HMP247CG
Swagelok for 12 mm probe, 3/8" ISO thread	SWG12ISO38
Swagelok for 12 mm probe, 1/2" NPT thread	SWG12NPT12



The HMT367 probe is constructed to be installed in environments with high humidities.

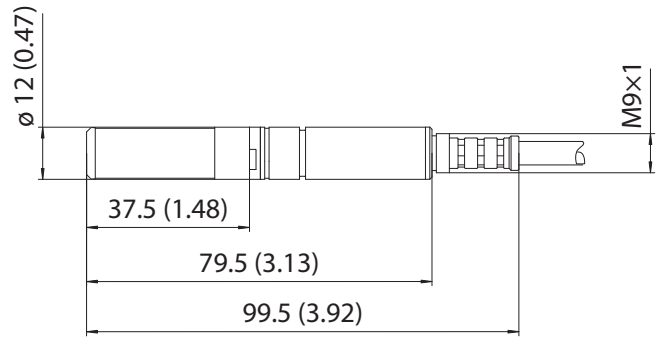

Dimensions in mm (inches)

HMT368 for Pressurized Pipelines

Temperature range	-70 ... +180 °C (-94 ... +356 °F)
Pressure range	0 ... 4 MPa
Probe cable length	2, 5 or 10 meters (6 ft 7 in, 16 ft 5 in, 32 ft 10 in)
Probe diameter	13.5 mm/12 mm (0.53 in/0.47 in)
Available probe lengths	226 mm/448 mm (8.90 in/17.6 in)
Installation	
Fitting body ISO1/2 solid structure	DRW212076SP
Fitting body NPT1/2 solid structure	NPTFITBODASP
Ball valve ISO 1/2 with welding joint	BALLVALVE-1



The HMT368 probe enables flexible installation in pressurized pipelines.

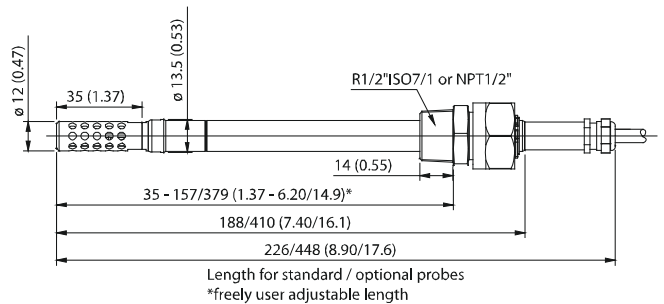

Dimensions in mm (inches)

HMT360 Series Technical Data

Measurement Performance

Relative Humidity

Measurement range	0 ... 100 %RH
Accuracy (Including Non-linearity, Hysteresis, and Repeatability):	
With Vaisala HUMICAP® 180R	For typical applications
At +15 ... +25 °C (59 ... +77 °F)	± 1.0 %RH (0 ... 90 %RH) ± 1.7 %RH (90 ... 100 %RH)
At -20 ... +40 °C (-4 ... +104 °F)	±(1.0 + 0.008 x reading) %RH
At -40 ... +180 °C (-40 ... +356 °F)	± (1.5 + 0.015 x reading) %RH
Factory calibration uncertainty (+20 °C)	± 0.6 %RH (0 ... 40 %RH) ± 1.0 %RH (40 ... 97 %RH)
(Defined as ±2 standard deviation limits. Small variations possible, see also calibration certificate.)	
Response Time (90 %) at +20 °C (+68 °F) in Still Air:	
With grid filter	17 s
With grid + steel netting filter	50 s
With sintered filter	60 s

Temperature

Measurement range	-70 ... +180 °C (-94 ... +356 °F) (depends on selected probe)
Typical accuracy of electronics at +20 °C (+68 °F)	±0.2 °C (0.36 °F)
Typical temperature dependence of electronics	0.005 °C/°C (0.005 °F/°F)
Sensor	Pt1000 RTD Class F0.1 IEC 60751

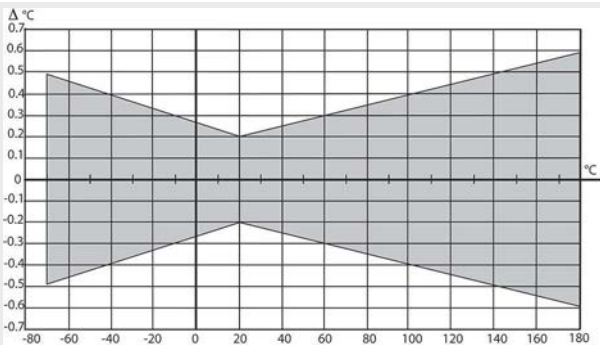

Accuracy over Temperature Range

Other Variables

Optionally available	Dew point temperature, mixing ratio, absolute humidity, wet bulb temperature
----------------------	--

Operating Environment

Operating temperature for electronics	-40 ... +60 °C (-40 ... +140 °F)
Operating temperature with display	-20 ... +60 °C (-4 ... +140 °F)
Storage temperature	-40 ... +70 °C (-40 ... +158 °F)
Pressure range	See probe specifications
EMC compliance	EN61326-1, Industrial Environment Note 1 HMT360 complies with IEC 61000-4-5 only when using external EXi approved surge arrester in the safe area. Note 2 Compliance with IEC 61000-4-3: <ul style="list-style-type: none"> • Within frequency range 80 ... 200 MHz immunity is 4 V/m • At 10 V/m RF field test within frequency range 80 ... 200 MHz may cause additional deviation of 1.5 %RH

Inputs and Outputs

Operating voltage	12 ... 28 V
With serial port (service mode)	15 ... 28 V
Analog outputs	Two-wire 4 ... 20 mA, one standard, one optional Connection via safety barriers
Typical accuracy of analog outputs at +20 °C	±0.05 % full scale
Typical temperature dependence of analog outputs	0.005 % / °C (0.005 % / °F) full scale
RS-232C serial output for service use (requires cable accessory 25905ZZ)	Connector type RJ45
Display	Two-line LCD

Mechanical Specifications

Connections	Screw terminals, 0.33 ... 2.0 mm ² wires (AWG 14-22)
Cable bushings	For 7.5 ... 12 mm or 10 ... 15 mm cable diameters (M20)
Conduit fitting	NPT 1/2"
Housing material	G-ALSi10Mg (DIN 1725)
Housing weight	950 g (2.1 lb)

Compliance

IP rating	IP66 (NEMA4X)
-----------	---------------

Accessory Availability

Accessory	Part number	Models
Ball valve ISO 1/2 with welding joint	BALLVALVE-1	HMT368
<ul style="list-style-type: none"> Pressure range at +20 °C (+68 °F) 0 ... 20 bar (0 ... 290 psia) (during installation max. 10 bar (145 psia)) 		
Cable gland M20 x 1.5 with splitting seal	HMP247CG	HMT363, HMT365, HMT367
Duct installation kit	210697	HMT363, HMT367
Fitting body ISO1/2 solid structure	DRW212076SP	HMT368
Fitting body M22 x 1.5	17223	HMT364
Fitting body NPT1/2	17225	HMT364
Fitting body NPT1/2 solid structure	NPTFITBODASP	HMT368
Mounting flange	210696	HMT365
Swagelok for 12mm probe, 1/2" NPT thread	SWG12NPT12	HMT363, HMT367
Swagelok for 12mm probe, 3/8" ISO thread	SWG12ISO38	HMT363, HMT367
Galvanic isolator	212483	All models
Zener barrier	210664	All models
Calibration adapter for HMK15	211302	HMT361, HMT363, HMT364, HMT367
Serial interface cable for PC connectors RJ45 - D9 female	25905ZZ	All models
Protection cover (for use in the presence of combustible dust, ATEX)	214101	All models
	II 1 D (IP65 T = 80 °C)	

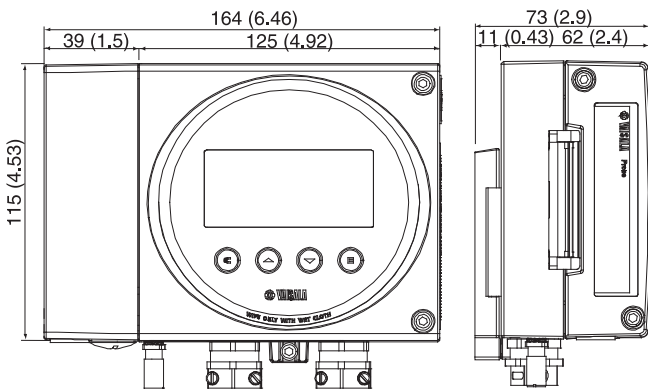

Dimensions in mm (inches)

Classification with Current Outputs

Europe / VTT

EU (94/9/EC, ATEX100a)	II 1 G Ex ia IIC T4 Ga Certificate No. VTT 09 ATEX 028 X
Safety factors	$U_i = 28 \text{ V}$, $I_i = 100 \text{ mA}$, $P_i = 700 \text{ mW}$ $C_i = 1 \text{ nF}$, L_i negligibly low

Environmental specifications

T_{amb}	-40 ... +60 °C (-40 ... +140 °F)
P_{amb}	0.8 ... 1.1 bar
Dust classification (with protection cover 214101)	II 1 D (IP65 T=+80 °C (+176 °F)) VTT 04 ATEX 023X

USA (FM)

USA (FM)	Classes I, II, III, Division 1, Groups A-G and Division 2, Groups A-D, F and G FM Project ID: 3010615
----------	--

Safety factors	$V_{max} = 28 \text{ VDC}$, $I_{max} = 100 \text{ mA}$, $C_i = 1 \text{ nF}$, $L_i = 0$, $P_i = 0.7 \text{ W}$, $T_{amb} = +60 \text{ °C (+140 °F)}$, T5
----------------	--

Japan (TIIS)

Japan (TIIS)	Ex ia IIC T4 Code number: TC20238
--------------	--------------------------------------

Safety factors	$U_i = 28 \text{ VDC}$, $I_i = 100 \text{ mA}$, $C_i = 1 \text{ nF}$, $P_i = 0.7 \text{ W}$, $L_i = 0$, $T_{amb} = +60 \text{ °C (+140 °F)}$
----------------	--

Canada (CSA)

Class I	Division 1 and Division 2, Groups A, B, C, D
---------	--

Class II	Division 1 and Division 2, Groups G and Coal Dust
----------	---

Class III	CSA File No: 213862 0 000, CSA Report: 1300863
-----------	--

Safety factors	$T_{amb} = +60 \text{ °C (+140 °F)}$, T4 Intrinsically safe when connected as per Installation Drawing DRW213478.
----------------	---

China (PCEC)

China (PCEC)	Ex ia II CT4 Certificate No. CE092145 Standard GB3836.1-2000 and GB3836.4-2000
--------------	--

IECEx (VTT)

IECEx (VTT)	Ex ia IIC T4 Ga Certificate No. IECEx VTT 09.0002x
-------------	---

Safety factors	$U_i = 28 \text{ V}$, $I_i = 100 \text{ mA}$, $P_i = 700 \text{ mW}$ $C_i = 1 \text{ nF}$, L_i negligibly low
----------------	---

Environmental specifications

T_{amb}	-40 ... +60 °C (-40 ... +140 °F)
P_{amb}	0.8 ... 1.1 bar
Dust classification (with protection cover 214101)	Ex ta IIC T500 80 °C Da IECEx VTT 12.0016X

EAC (Russia, Kazakhstan, Belarus) (TRCU)

EAC (Russia, Kazakhstan, Belarus) (TRCU)	0Ex ia IIC T4 Ga X Certificate No. RU C- FI.MLJ06.B.00068
--	---

Environmental specifications

T_{amb}	-40 ... +60 °C (-40 ... +140 °F)
P_{amb}	0.8 ... 1.1 bar

Korea (KOSHA)

Korea (KOSHA)	Ex ia IIC T4 Certificate No. 17-AV4BO-0419X
---------------	--

Safety factors	$U_i = 28 \text{ V}$, $I_i = 100 \text{ mA}$, $P_i = 700 \text{ mW}$ $C_i = 1 \text{ nF}$, $L_i =$ negligibly low
----------------	---

Environmental specifications

T_{amb}	-40 ... +60 °C (-40 ... +140 °F)
P_{amb}	0.8 ... 1.1 bar





HMT310 Series Humidity and Temperature Transmitters

For Demanding Industrial Applications



Features

- 4th generation Vaisala HUMICAP® sensor for superior accuracy and stability
- Full 0 ... 100 %RH measurement, temperature range up to +180 °C (+356 °F), depending on model
- Small size, easy to integrate
- Insensitive to dust and most chemicals
- Two analog signals and RS-232 ASCII output
- Pressure tolerance up to 100 bar

HMT310 incorporates the latest generation Vaisala HUMICAP® sensor. The sensor is a capacitive thin-film polymer sensor providing high accuracy, excellent long-term stability and negligible hysteresis. It is insensitive to dust, particulate dirt and most chemicals. HMT310 has various options for different environments and measurements.

Several Outputs, One Connector

HMT310 is powered up with 10 ... 35 VDC. It has two analog outputs and an RS-232 serial output in one M12/8 pin connector. The output signal and the supply power travel in the same cable, the only cable connected to the unit.

Chemical Purge

Chemical purge helps to maintain measurement accuracy between calibration intervals. It involves heating the sensor to remove harmful chemicals. The function can be initiated manually or programmed to occur at set intervals.

Optional Functions

The following optional functions are available: several probes for various applications, calculated humidity quantities, variety of mounting kits, rain shield, sensor protection options and probe cable lengths, warmed probe and sensor heating for high humidity conditions, and chemical purge for applications risking an interference with chemicals in the measuring environment.

The HMT310 series includes six models for demanding applications:

- HMT311 for wall mounting

- HMT313 for duct mounting and tight spaces
- HMT314 for high pressures up to 100 bar and vacuum conditions
- HMT315 for high temperatures
- HMT317 for high humidity applications, warmed probe option
- HMT318 for pressurized pipelines up to 40 bar

Technical Data

Measurement Performance

Relative Humidity

Measurement range	0 ... 100 %RH
-------------------	---------------

Sensor:

Vaisala HUMICAP180R	Typical applications
---------------------	----------------------

Vaisala HUMICAP180RC	Applications with chemical purge/warmed probe
----------------------	---

Vaisala HUMICAP180V	Catalytic sensor for H ₂ O ₂ environments
---------------------	---

Vaisala HUMICAP180VC	Catalytic sensor with chemical purge for H ₂ O ₂ environments
----------------------	---

Response time (90 %) at +20 °C (+68 °F) in 0.1 m/s air flow	17 s with grid filter 50 s with grid and steel, netting filter 60 s with sintered filter
---	--

Factory calibration uncertainty (+20 °C)	±0.6 %RH (0 ... 40 %RH) ¹⁾ ±1.0 %RH (40 ... 97 %RH) ¹⁾
--	---

Accuracy (Including Non-Linearity, Hysteresis, and Repeatability) at a Temperature Range of:

+15 ... +25 °C (+59 ... +77 °F)	±1 %RH (0 ... 90 %RH) ±1.7 %RH (90 ... 100 %RH)
---------------------------------	--

-20 ... +40 °C (-4 ... +104 °F)	±(1.0 + 0.008 x reading) %RH
---------------------------------	------------------------------

-40 ... +180 °C (-40 ... +356 °F)	±(1.5 + 0.015 x reading) %RH
-----------------------------------	------------------------------

Temperature

HMT311	-40 ... +60 °C (-40 ... +140 °F)
--------	----------------------------------

HMT313	-40 ... +80 °C (-40 ... +176 °F) or -40 ... +120 °C (-40 ... +248 °F)
--------	--

HMT314, HMT315, HMT317, HMT318	-70 ... +180 °C (-94 ... +356 °F)
--------------------------------	-----------------------------------

Typical accuracy at +20 °C (+68 °F)	±0.2 °C (±0.36 °F)
-------------------------------------	--------------------

Temperature sensor	Pt100 RTD Class F0.1 IEC 60751
--------------------	--------------------------------

¹⁾ Defined as ±2 standard deviation limits. Small variations possible, see also calibration certificate.

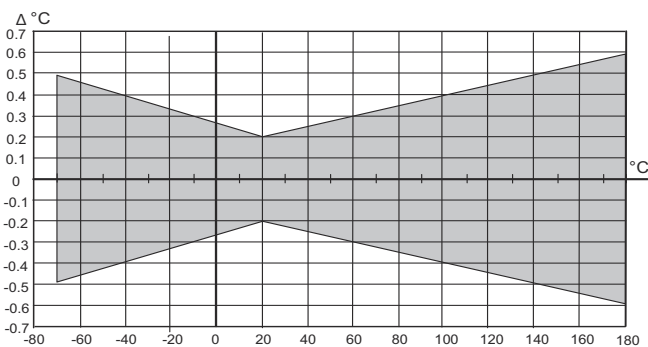

Accuracy over temperature range

Operating Environment

Operating temperature for electronics	-40 ... +60 °C (-40 ... +140 °F)
---------------------------------------	----------------------------------

Storage temperature	-55 ... +80 °C (-67 ... +176 °F)
---------------------	----------------------------------

Operating pressure

HMT314	0 ... 100 bar
--------	---------------

HMT318	0 ... 40 bar
--------	--------------

HMT315, HMT317	vapor tight
----------------	-------------

EMC compliance	EN61326-1, Industrial environment
----------------	-----------------------------------

Inputs and Outputs

Two analog outputs, selectable and scalable	0 ... 20 mA or 4 ... 20 mA 0 ... 5 V or 0 ... 10 V 1 ... 5 V available through scaling
---	--

Typical accuracy of analog output at +20 °C	±0.05 % full scale
---	--------------------

Typical temperature dependence of analog output	0.005 %/°C (0.003 %/°F) of full scale
---	---------------------------------------

Serial output	RS232C
---------------	--------

Connections	M12 8-pole connector with RS232C, current/voltage outputs (two channels) and U _{in}
-------------	--

Operating voltage	10 ... 35 VDC
-------------------	---------------

External load	R _L < 500 Ω
---------------	------------------------

Startup time after power-up	3 s
-----------------------------	-----

Minimum Operating Voltage

RS-232C output	10 VDC
----------------	--------

Analog output	15 VDC
---------------	--------

Probe heating and chemical purge	15 VDC
----------------------------------	--------

Pressures above 10 bara (145 psia)	24 VDC
------------------------------------	--------

Power Consumption

RS-232	12 mA
--------	-------

U _{out} 10 V (10 kΩ) channel 1 & channel 2	12 mA
---	-------

I _{out} 20 mA (load 511 Ω) channel 1 & channel 2	50 mA
---	-------

Chemical purge at 24 VDC	+ 220 mA
--------------------------	----------

Warmed probe at 24 VDC	+ 240 mA
------------------------	----------

Mechanical Specifications

Transmitter housing material	G-AISI10Mg
------------------------------	------------

Transmitter base material	PPS
---------------------------	-----

IP rating	IP66
-----------	------

Probe cable length	2 m, 5 m, or 10 m
--------------------	-------------------

Cable feed through alternatives	8-pole connector with 5 m cable, Female 8-pin connector screw joint for cable diameter 4 ... 8 mm
---------------------------------	---

Sensor protection	PPS grid with stainless steel net, PPS grid, Sintered filter, Membrane stainless steel filter, H ₂ O ₂ filter
-------------------	---

Spare Parts and Accessories

Rain shield	ASM211103
-------------	-----------

USB cable	238607
-----------	--------

PPS Plastic Grid with Stainless Steel Netting	DRW010281SP
---	-------------

PPS Plastic Grid Filter	DRW010276SP
-------------------------	-------------

Sintered Filter AISI 316L	HM47280SP
---------------------------	-----------

Stainless Steel Filter	HM47453SP
------------------------	-----------

Stainless Steel Filter with Membrane	214848SP
--------------------------------------	----------

Catalytic H ₂ O ₂ Filter	231865
--	--------

Probe dimensions in mm (inches)

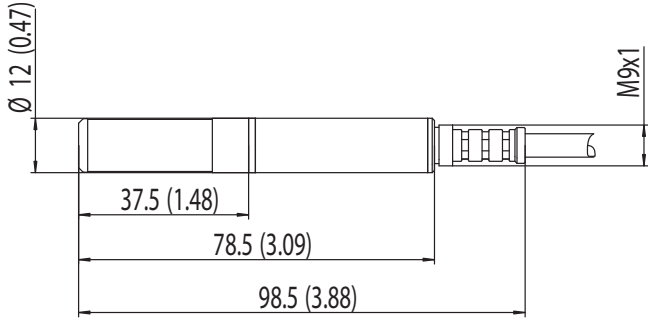

HMT313 Probe

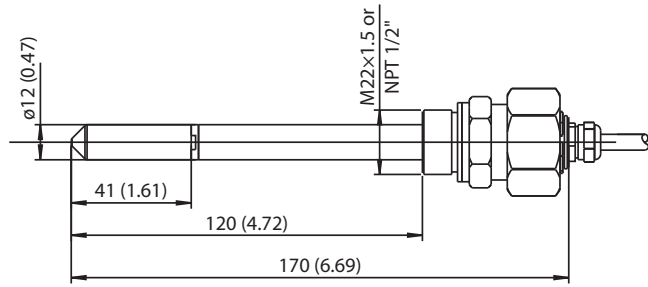

HMT314 Probe

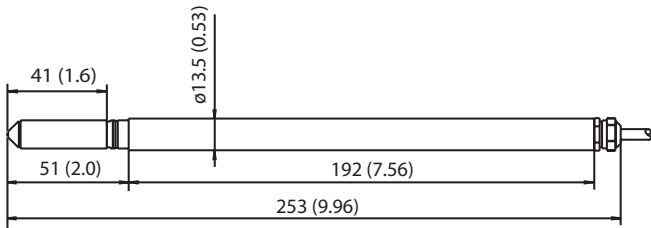

HMT315 Probe

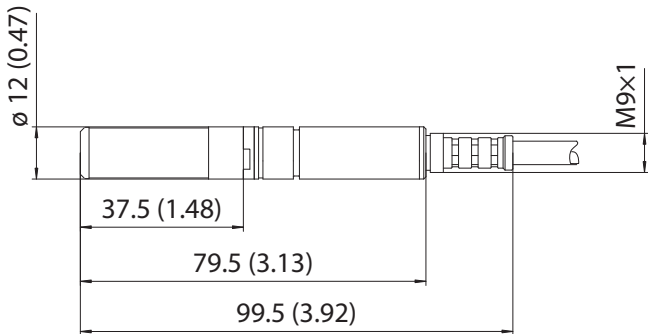

HMT317 Probe

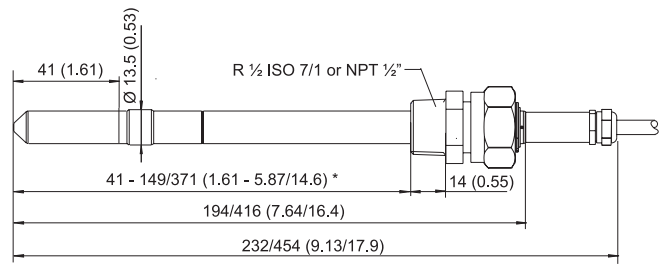

Lengths for standard / optional probes
* freely user-adjustable length

HMT318 Probe

Transmitter body dimensions in mm (inches)

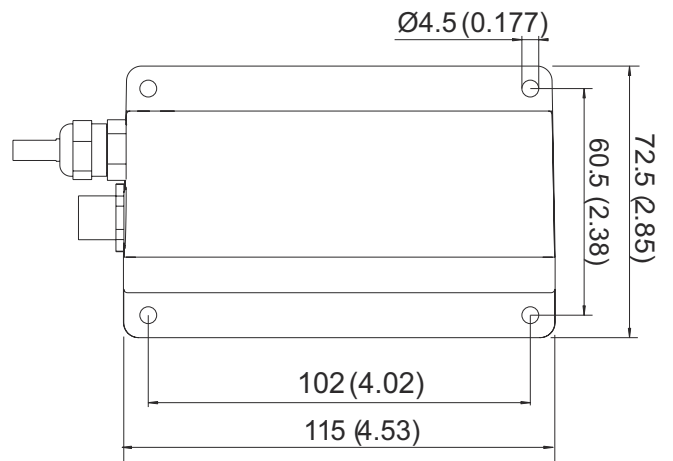
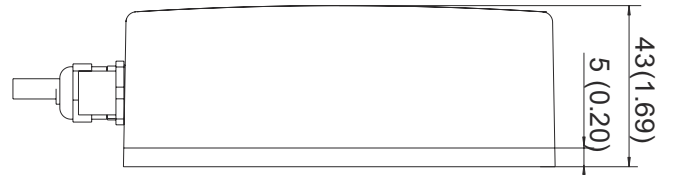



Features

- Vaisala HUMICAP® technology with humidity sensor HUMICAP® 180R
- Interchangeable probe (easy field calibration)
- Accurate and reliable
- Resistant to dust and most chemicals
- Enclosure IP65
- 3-point traceable calibration (certificate included)
- Suitable for cleanrooms and demanding HVAC and light industrial applications

Vaisala HUMICAP® Humidity and Temperature Transmitters HMT120 and HMT130 are designed for humidity and temperature monitoring in cleanrooms and are also suitable for demanding HVAC and light industrial applications.

Options

- Humidity parameter options: relative humidity, dew point/frost point, wet bulb temperature, enthalpy, absolute humidity, mixing ratio, vapor pressure, and saturation vapor pressure
- 2-wire loop-powered or 3-wire voltage output configurations
- Optional LCD display
- USB cable available for a PC connection for maintenance
- Wall-mounted or with a remote probe
- Constant output probe available
- Can be mounted outdoors using a Vaisala installation kit and the Vaisala Radiation Shield DTR504A

Performance

HMT120/130 incorporates Vaisala HUMICAP® technology that measures relative humidity accurately and reliably. Vaisala HUMICAP® is resistant to dust and most chemicals.

The transmitter enclosure is optimized for use in cleanrooms. The smooth surface of the enclosure makes it easy to clean and the enclosure material is chosen to tolerate purifying agents. Furthermore, the cabling can be done through the back wall of the transmitter.

Interchangeable Probe

The HMT120/130 transmitters use a fully interchangeable relative humidity probe. The probe can be easily removed and replaced with a new one without having to adjust the transmitter, which allows for

easy and quick recalibration of the transmitter. The probe can be adjusted using one of Vaisala's portable meters as a reference.

Also available is a constant output probe with fixed RH and T output for convenient inspection of the monitoring system and signal transfer line.

Available Options

The HMT120 and HMT130 transmitters are available as wall mounted or with a remote probe. For high temperature applications or where space is limited, the remote probe is ideal. The optional LCD display shows the measurement results of selected parameters in selected units. The parameters are displayed simultaneously at two separate rows on the display.

Technical Data

Measurement Performance

Relative Humidity

Measurement range	0 ... 100 %RH
Accuracy (including non-linearity, hysteresis, and repeatability) at 0 ... +40 °C (+32 ... +104 °F):	
0 ... 90 %RH	±1.5 %RH
90 ... 100 %RH	±2.5 %RH
Accuracy (including non-linearity, hysteresis, and repeatability) at -40 ... 0 °C, +40 ... +80 °C (-40 ... +32 °F, +104 ... +176 °F):	
0 ... 90 %RH	±3.0 %RH
90 ... 100 %RH	±4.0 %RH
Factory calibration uncertainty at +20 °C (+68 °F):	
0 ... 90 %RH	±1.1 %RH
90 ... 100 %RH	±1.8 %RH
Humidity sensor	Vaisala HUMICAP® 180R
Stability	±2 %RH over 2 years
Stability in typical HVAC applications	±0.5 %RH per year

Temperature

Measurement range	-40 ... +80 °C (-40 ... 176 °F)
Accuracy over Temperature Range:	
At +15 ... +25 °C (+59 ... +77 °F)	±0.1 °C (±0.18 °F)
At 0 ... +15 °C and at +25 ... +40 °C (+32 ... +59 °F and +77 ... +104 °F)	±0.15 °C (±0.27 °F)
At -40 ... +0 °C and at +40 ... +80 °C (-40 ... +32 °F and +104 ... +176 °F)	±0.4 °C (±0.72 °F)
Temperature sensor	Pt1000 RTD Class F0.1 IEC 60751

Other Variables (Optional)

Dew point/frost point, wet bulb temperature, enthalpy, absolute humidity, mixing ratio, vapor pressure, and saturation vapor pressure

Inputs and Outputs

HMT120 Two-wire Transmitter (Loop Powered)

Current output signals	4 ... 20 mA
External loop voltage	10 ... 30 VDC ($R_L = 0 \Omega$) 20 ... 30 VDC ($R_L < 500 \Omega$)

HMT130 Three-wire Transmitter

Voltage output signals	0 ... 1 V, 0 ... 5 V, 0 ... 10 V or user defined between 0 ... 10 V
Min. output resistance	1 kΩ
Serial output	RS-485, non-isolated
Relay output	1 relay (max. 50 VDC, 200 mA)
Supply voltage	10 ... 35 VDC 15 ... 35 VDC (when output 0 ... 10 V) 24 VAC (±20 %)
Current consumption at 24 VDC	8 mA, if relay closed 15 mA
Max. additional error caused by the analog outputs after calibration at +20 °C (+68 °F) ambient temperature	±0.1 % of FS output signal
Temperature dependence of the analog outputs	±0.005 % of FS output signal

Operating Environment

Operating temperature of transmitter body, no display	-40 ... +60 °C (-40 ... +140 °F)
Operating temperature of transmitter body with display	-20 ... +60 °C (-4 ... +140 °F)
Operating temperature, HMP110 probe	-40 ... +80 °C (-40 ... +176 °F)
Storage temperature	-50 ... +70 °C (-58 ... +158 °F)
EMC compliance	EN 61326-1 and EN 55022

Mechanical Specifications

IP rating	IP65
Weight	270 g (9.5 oz)
Probe cable lengths	3 m, 5 m, 10 m - up to 50 m (9.8 ft, 16 ft, 33 ft - up to 164 ft)
Display (optional)	128 x 64 resolution full graphics B&W display without backlight
Material	
Transmitter housing	PBT plastic
Display window	PC plastic
Probe body	Stainless steel (AISI 316)
Probe grid filter	Chrome coated ABS plastic
Connections	
Inputs and outputs	Screw terminals 0.5 ... 1.5 mm ² (AWG 20 ... AWG 15)
Probe interface	4-pin M8 female panel connector

Spare Parts and Accessories

Humidity and temperature probe	HMP110 ¹⁾
Humidity and temperature replacement probe	HMP110R ¹⁾
Constant output probe	HMP110REF ¹⁾
Standard humidity sensor	HUMICAP180R
Catalytic humidity sensor for H ₂ O ₂	HUMICAP180V
Probe mounting flange	226061
Probe mounting clamps, 10 pcs	226067
Probe cable 3 m (9.8 ft)	HMT120Z300
Probe cable 5 m (16 ft)	HMT120Z500
Probe cable 10 m (33 ft)	HMT120Z1000
Probe cable 20 m (66 ft)	HMT120Z2000
Radiation shield	DTR504A
Rain shield with installation kit	215109
Duct installation kit	215619
HM70 connection cable	211339
USB serial interface cable	219685

HMP110 Sensor Protection

Plastic grid filter	DRW010522SP
Plastic grid with membrane filter	DRW010525SP
Stainless steel sintered filter	HM46670SP
Teflon sintered filter	DRW244938SP

¹⁾ See separate order form

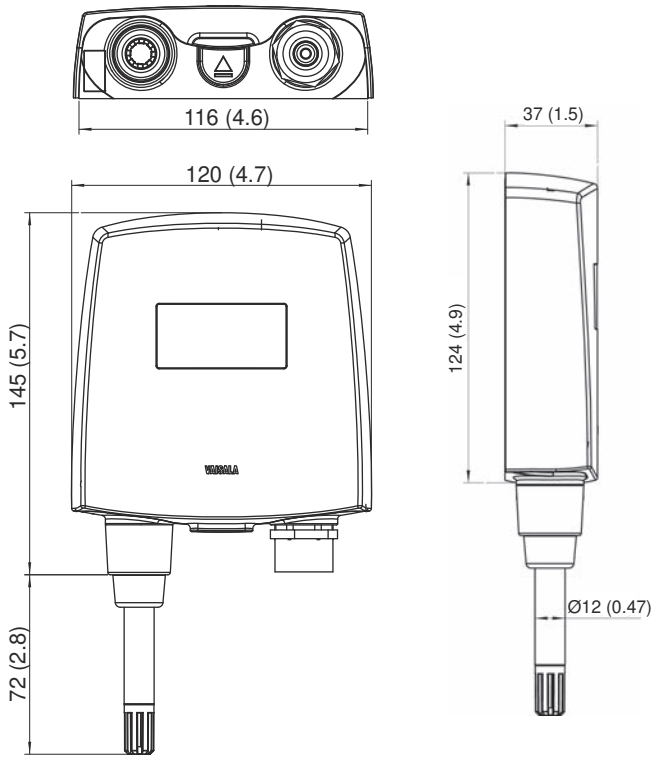

Transmitter dimensions in mm (inches)

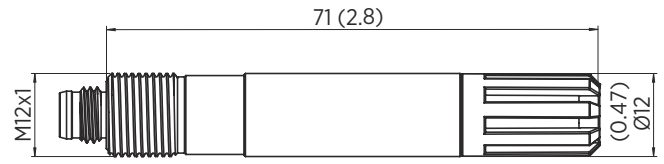

Remote probe dimensions in mm (inches)



HMW90 Series Humidity and Temperature Transmitters

For High-performance HVAC Applications



Features

- Both analog and digital output
- Easy installation, configuration, and field adjustment
- Humidity parameter options: relative humidity, dew point, mixing ratio, enthalpy, wet bulb temperature, dew point depression, and absolute humidity
- Full 0 ... 100 %RH measurement range
- Up to ± 1.7 %RH accuracy
- User exchangeable humidity and temperature module
- Traceable calibration (certificate included)
- Available in two colors

Wall-mounted Vaisala HMW90 Series HUMICAP® Humidity and Temperature Transmitters measure relative humidity and temperature in indoor HVAC applications, where high accuracy, stability, and reliable operation are required.

The flexible HMW90 series offers a variety of options and features. Transmitters include a display and a sliding cover with either an opening for the display or a solid front. Both analog and digital output options, including special scalings and calculated parameters, are available.

Quick and Easy to Install

HMW90 series transmitters are quick and easy to install. The wiring is connected through the back plate and the electronics with the sensors can be snapped on easily after the wiring is complete. The transmitter is configured using DIP switches, which are accessible when the enclosure is open.

Digital Communication Brings Benefits

The introduction of digital (BACnet/Modbus) communication to field level devices brings many advantages. For example, all sensors can be centrally accessed and their performance can be easily monitored. Wiring is simple when multiple sensors are installed on the same bus. Sensors can be set up using standardized tools, and the system can be expanded with additional sensors quickly and conveniently. In addition, parameters influencing measurements, such as pressure or site elevation, can be centrally set and updated.

Choose from a Wide Variety of Calibration Options

On-site calibration and adjustment is exceptionally easy. The sliding cover exposes offset trimmers for one-point calibration without disturbing measurement. The display instantly indicates the effects of changes, making it clear and convenient to make adjustments. A service port enables two-point calibration, using either a PC or Vaisala HUMICAP® Handheld Humidity and Temperature Meter HM70. HMW90 series transmitters include a user-exchangeable measurement module, which can be ordered as a spare part.

Model	Measurements	Output
TMW92	T-only	2-wire, current output
TMW93	T-only	3-wire, voltage output
TMW90	T-only	Configurable analog output model
HMW92	RH+T	2-wire, current output
HMW92D	RH+T	2-wire, current output with display
HMW93	RH+T	3-wire, voltage output
HMW93D	RH+T	3-wire, voltage output with display
HMW90	RH+T	Configurable analog/digital model
HMW95	RH+T	Digital (BACnet, Modbus) model
HMW95D	RH+T	Digital (BACnet, Modbus) model with display

Technical Data

Measurement Performance

Relative Humidity

Measurement range	0 ... 100 %RH, non-condensing
Accuracy at temperature range +10 ... +40 °C (+50 ... +104 °F):	
0 ... 90 %RH	±1.7 %RH
90 ... 100 %RH	±2.5 %RH
Accuracy at temperature range -5 ... +10 °C, +40 ... +55 °C (+23 ... +50 °F, +104 ... +131 °F):	
0 ... 90 %RH	±3 %RH
90 ... 100 %RH	±4 %RH
Stability in typical HVAC applications	±0.5 %RH/year
Humidity sensor	Vaisala HUMICAP® 180R

Temperature

Measurement range	-5 ... +55 °C (+23 ... +131 °F)
Accuracy at +20 ... +30 °C (+68 ... +86 °F)	±0.2 °C (± 0.36 °F)
Accuracy at +10 ... +20 °C, +30 ... +40 °C (+50 ... +68 °F, +86 ... +104 °F)	±0.3 °C (± 0.54 °F)
Accuracy at -5 ... +10 °C, +40 ... +55 °C (+23 ... +50 °F, +104 ... +131 °F)	±0.5 °C (± 0.90 °F)
Temperature sensor	Digital temperature sensor

Operating Environment

Operating temperature	-5 ... +55 °C (+23 ... +131 °F)
Storage temperature	-30 ... +60 °C (-22 ... +140 °F)
EMC compliance	EN61326-1, Industrial Environment

Mechanical Specifications

IP rating	IP30
Weight	155 g (5.5 oz)
Standard housing color	White (RAL9003 ¹⁾)
Optional housing color (configurable models only)	Black (RAL9005 ¹⁾)
Housing material	ABS/PC, UL-V0 approved
Output connector	Screw terminals Max. wire size 2 mm ² (AWG14)
Service port connector	4-pin M8

¹⁾ RAL code is only indicative with potential small variations in color shade.

Spare Parts and Accessories

Humidity and Temperature Module	HTM10SP
Temperature Module (for T-only models)	TM10SP
Decorative cover set (10 pcs.)	236285
Connection cable for HM70 hand-held meter	219980
USB cable for PC connection	219690

Inputs and Outputs

Service port RS-485 line for temporary service use

Current Output Models

Outputs	2 x 4 ... 20 mA, loop powered
Loop resistance	0 ... 600 Ω
Supply voltage	20 ... 28 VDC at 500 Ω load 10 ... 28 VDC at 0 Ω load
Isolation between output channels	500 VDC

Voltage Output Models

Outputs	2 x 0 ... 5 V or 2 x 0 ... 10 V
Load resistance	10 kΩ min.
Supply voltage	18 ... 35 VDC, 24 VAC ±20 % 50/60 Hz
Max. current consumption	12 mA Max. with relay 25 mA
Relay	1 pc (max 50 VDC/50 VAC, 500 mA)

Digital Models

Supply voltage	18 ... 35 VDC, 24 VAC ± 20 % 50/60 Hz
Max. current consumption (with 120 Ω termination)	30 mA at 24 VDC
Output type	RS-485 (galvanic isolation, 1.5 kV)
RS-485 end of line termination	Enable with jumper, 120 Ω
Supported protocols	BACnet MS/TP or Modbus RTU (selectable by DIP switch)
BACnet MS/TP Operating mode	Selectable Master/Slave
Address range, master mode	0 ... 127
Address range, slave mode	128 ... 255
Modbus RTU address range	0 ... 247

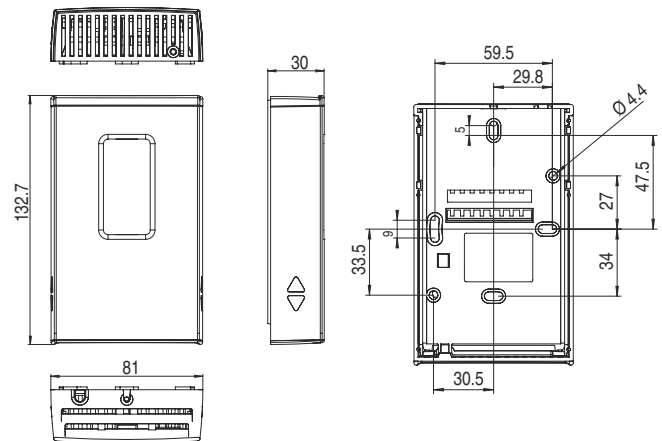

Dimensions in mm



Features

- Measurement accuracy up to ± 1.5 %RH and ± 0.1 °C (± 0.18 °F)
- Analog output transmitter model options: HMD62 (RH and T) and TMD62 (T-only)
- All common humidity parameters available, including RH, dew point, enthalpy, and wet bulb temperature
- 4 ... 20 mA analog output
- Resistant to chemicals and dust
- IP66-rated body
- Traceable calibration certificate
- Easy field adjustment and output configuration with quick access to transmitter electronics also when installed
- Compatible with Vaisala Insight PC software

The duct mounted HMD60 series HUMICAP® transmitters are designed for light industrial applications and demanding HVAC applications such as museums, cleanrooms, and laboratories.

Robust Design, Stability, and Reliability

The all-metal body is suitable for building sites and industrial settings. HMD60 series transmitters provide state-of-the-art stability and environmental resistance thanks to the Vaisala HUMICAP® R2 sensor.

Traceable Accuracy

HMD60 transmitters are always delivered with a traceable (ISO9001) calibration certificate. Upon request, accredited (ISO17025) calibration certificates can also be provided.

Field Configurable Outputs

The analog HMD62 and TMD62 transmitter models use floating 4 ... 20 mA loop powered output. The analog outputs are field configurable with easy parameter selection using DIP switches. For special scaling and other additional configuration and adjustment options, you can use the convenient Vaisala Insight PC software for Windows® (see www.vaisala.com/insight).

When required, HMD60 can also be intuitively field adjusted using trimmers or with the Vaisala HM70 hand-held meter.

Technical Data

Relative Humidity Measurement Performance

Humidity sensor	Vaisala HUMICAP®R2
Measurement range	0 ... 100 %RH
Stability	±2.5 %RH over 2 years
Accuracy at 0 ... +40 °C (+32 ... +104 °F) (Incl. Non-Linearity, Hysteresis and Repeatability)	
0...90%RH	±1.5%RH
90...100%RH	±2.5%RH
Accuracy at +40 ... +80 °C (+104 ... +176 °F) and -40 ... 0 °C (-40 ... +32 °F) (Incl. Non-Linearity, Hysteresis and Repeatability)	
0 ... 90 %RH	±2.5%RH
90 ... 100 %RH	±3.5%RH
Factory calibration uncertainty	±1.0 %RH
Start-up and Response Time	
Start-up time at +20 °C (+68 °F)	8 s
Response time (T63) at +20 °C (+68 °F)	15 s
Calculated Humidity Parameters (Default Analog Output Scale)	
Dew point	-40 ... +80 °C (-40 ... +176 °F)
Dew point / frost point	-40 ... +80 °C (-40 ... +176 °F)
Absolute humidity	0 ... 300 g/m ³ (0 ... 131.1 gr/ft ³)
Wet bulb temperature	-40 ... +80 °C (-40 ... +176 °F)
Enthalpy	-40 ... 1600 kJ/kg (-9.5 ... 695.6 Btu/lb)
Mixing ratio	0 ... 600 g/kg (0 ... 4200 gr/lb)

Temperature Measurement Performance

Measurement range	-40 ... +80 °C (-40 ... +176 °F)
Default analog output scale	-20 ... +80 °C (-4 ... +176 °C)
Accuracy at +20 °C (+68 °F)	±0.1 °C (0.18 °F)
Temperature dependence	±0.005°C/°C
Factory calibration uncertainty	±0.1 °C (0.18 °F)
Response time (T63) with free convection	8 min

Operating Environment

Operating temperature, electronics	-40 ... +60 °C (-40 ... +140 °F)
Operating temperature, probe	-40 ... +80 °C (-40 ... +176 °F)
Storage temperature range	-40 ... +80 °C (-40 ... +176 °F)
Maximum flow speed	50 m/s with sintered filter
Electromagnetic compatibility	EN61326-1, Industrial Environment

Mechanical Specification

Housing material	Cast aluminium
Probe material	Stainless steel
IP rating	IP66 (NEMA 4X)
Weight	511 g (18 oz)

Inputs and Outputs

Power supply input	10 ... 35 VDC (RL = 0 Ω) 20 ... 35 VDC (RL = 600 Ω)
Analog outputs	<ul style="list-style-type: none"> TMD62: 1 x T output 4 ... 20 mA HMD62: 1 x RH output 4 ... 20 mA, 1 x T output 4 ... 20 mA Calculated output parameters for HMD62 include T_d, T_{df}, A, X, T_w, and H.
Service port	M8 4-pin male connector: <ul style="list-style-type: none"> MI70 hand-held indicator (requires cable 219980SP) Vaisala Insight PC software¹⁾ (requires USB cable 219690)
Screw terminal wire size	0.5 ... 2.5 mm ²

¹⁾ Vaisala Insight software for Windows® available at www.vaisala.com/insight.

Spare Parts and Accessories

USB cable for PC operation (Vaisala Insight software)	219690
Connection cable for HM70 (MI70) hand-held meter	219980SP
Membrane filter	ASM212652SP
Sintered filter	HM46670SP
Conduit fitting and O-ring (M16x1.5 / NPT1/2")	210675SP

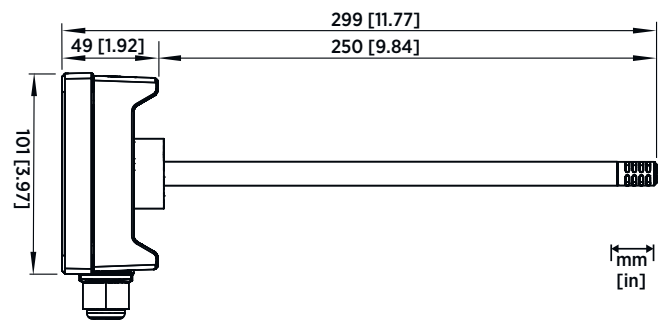
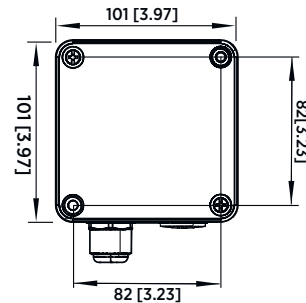

HMD60 Dimensions (Front and Side)



HMDW110 Series Humidity and Temperature Transmitters

For High-accuracy Measurements in HVAC Applications



Features

- Accurate humidity and temperature transmitters for measurements in HVAC and cleanroom applications
- Outdoor transmitter with professional-grade radiation shield
- Proven HUMICAP® 180R sensor for superior long-term stability
- ± 2 %RH accuracy
- 3-point traceable calibration (certificate included)
- On-site calibration with HM70 Hand-Held Meter or Vaisala Insight PC software
- Current (4 ... 20 mA) or Modbus RTU output variants
- Default output parameters are relative humidity and temperature. Dew point temperature, wet bulb temperature, and enthalpy outputs selectable with Vaisala Insight PC software.

Vaisala HUMICAP® Humidity and Temperature Transmitter Series HMDW110 measure relative humidity and temperature in multiple HVAC applications. The series includes transmitters for duct mounting, IP65-classified wall transmitters, and outdoor transmitters with integrated radiation shields.

Proven Vaisala HUMICAP® Performance

The cost-efficient HMDW110 series transmitters are equipped with trusted HUMICAP® 180R sensors. The sensor's superior long-term stability minimizes maintenance needs throughout the transmitter's lifetime. If necessary, the transmitter can be field-calibrated using either an HM70 Hand-Held Humidity and Temperature Meter, or Vaisala Insight PC software. HMDW110 series instruments are individually adjusted and delivered with a traceable calibration certificate.

Unrivaled Outdoor Humidity Measurements

The integrated radiation shield of the outdoor models HMS110 and HMS112 enables unrivaled measurement performance. It reduces the impact of sunshine on temperature and humidity measurements, and ensures measurement accuracy in outdoor conditions. The most popular control parameters in free cooling – dew point temperature, wet bulb temperature, and enthalpy – are available as output parameters.

Well-suited for Cleanroom Monitoring

The HMD110 and HMW110 transmitters can be ordered with the catalytic HUMICAP® sensor HUMICAP® 180V. The catalytic sensor improves stability especially in hydrogen peroxide sterilized environments where repeated condensation is expected. An optional panel display can be added for remote monitoring. Transmitters can be installed into difficult-to-reach locations, while measurement data can be read from a more convenient spot.

Technical Data

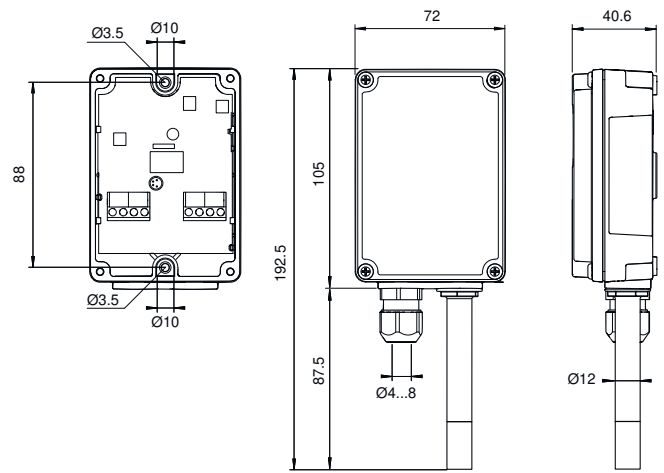

Dimensions in mm

HMW110/112 RH+T transmitters for measurements in wet areas

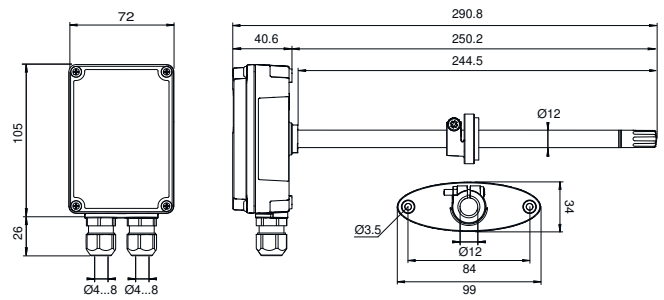

Dimensions in mm

HMD110/112 RH+T transmitters for ducts

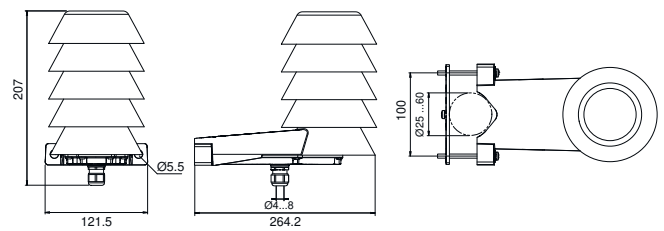

Dimensions in mm

HMS110/112 RH+T transmitters for outdoor measurements

Models

Model Number	Type	Output	Special Features	Ingress Protection
HMW110	Wall-mount, RH+T	2-wire current or Modbus RTU output	Configurable model ¹⁾	IP65
HMW112	Wall-mount, RH+T	2-wire current output		IP65
HMD110	Duct-mount, RH+T	2-wire current or Modbus RTU output	Configurable model ¹⁾	IP65
HMD112	Duct-mount, RH+T	2-wire current output		IP65
HMS110	Outdoor, RH+T	2-wire current or Modbus RTU output	Radiation shield, configurable model ¹⁾	IP65
HMS112	Outdoor, RH+T	2-wire current output	Radiation shield	IP65

¹⁾ Delivered with customer specific output settings, including calculated humidity parameters and special scaling of outputs.

Measurement Performance

Relative Humidity

Measurement range	0 ... 100 %RH
Accuracy at temperature range +10 ... +30 °C (+50 ... +86 °F)	
0 ... 90 %RH	±2 %RH
90 ... 100 %RH	±3 %RH
Accuracy at temperature range -20 ... +10 °C, +30 ... +60 °C (-4 ... +50 °F, +86 ... +140 °F)	
0 ... 90 %RH	±3 %RH
90 ... 100 %RH	±4 %RH
Accuracy at temperature range -40 ... -20 °C (-40 ... -4 °F)	
0 ... 100 %RH	±4 %RH
Stability in typical HVAC applications	±0.5 %RH/year
Humidity sensor	Vaisala HUMICAP® 180R

Temperature

Measurement range	-40 ... +60 °C (-40 ... +140 °F)
Accuracy at +20 °C (+68 °F)	±0.2 °C (±0.36 °F)
Temperature dependence	±0.01 °C/°C
Temperature sensor	Pt1000 RTD Class F0.1 IEC 60751

Calculated Parameters

Measurement range for dew point temperature and wet bulb temperature	-40 ... +60 °C (-40 ... +140 °F)
Measurement range for enthalpy	-40 ... 460 kJ/kg (-10 ... +190 BTU/lb)

Accuracy of the calculated parameters should be calculated at the actual condition based on the RH and temperature specification.

Accuracy at 20 °C (68 °F) and 80 %RH:

Dew point	±0.7 °C (1.2 °F)
Wet bulb temperature	±0.5 °C (0.9 °F)
Enthalpy	±1.6 kJ/kg (0.7 BTU/lb)
Factory calibration uncertainty at 20 °C (+68 °F)	±1.5 %RH/±0.2 °C

Operating Environment (All Models)

Operating temperature	-40 ... +60 °C (-40 ... +140 °F)
Operating humidity	0 ... 100 %RH
Maximum wind/flow speed	30 m/s
Storage temperature	-40 ... +60 °C (-40 ... +140 °F)
Electromagnetic compliance	EN61326-1, Industrial Environment

Inputs and Outputs

Devices Ordered With Analog Output

Outputs	4 ... 20 mA, loop powered
Loop resistance	0 ... 600 Ω
Supply voltage	20 ... 28VDC at 600 Ω load 10 ... 28VDC at 0 Ω load
Interface for RDP100 Remote Display Panel	Power and data supplied from transmitter

Devices Ordered With Modbus Output

Interface	RS-485, not isolated, no line termination
Default serial settings	19200 bps N 8 2
Protocols	Modbus RTU
Supply voltage	10 ... 28VDC

Spare Parts and Accessories

Remote Display Panel	RDP100
Conduit fitting + O-ring (M16x1.5 / NPT1/2 Inch)	210675SP
Conduit fitting + O-ring (M16x1.5 / PG9, RE-MS)	210674SP
Fastening set HMS110	237805
Fastening flange assembly (screws included)	ASM210771SP
Porous PTFE Filter	DRW239993SP
Membrane Filter	ASM210856SP
Terminal Block, Blue	236620SP
USB cable for PC connection	219690
Connection cable for HM70 hand-held meter	219980SP
HUMICAP® 180R sensor	HUMICAP180R
Catalytic HUMICAP® sensor	HUMICAP180V

Mechanical Specifications

Maximum wire size	1.5 mm ² (AWG 16)
Standard housing color	White (RAL9003)
Housing material	PC + 10 %GF (UL-V0 approved)

VAISALA

www.vaisala.com

HMS110 Series Humidity and Temperature Transmitters

For High-accuracy Outdoor Measurements in Building Automation Applications



Features

- Reliable outdoor transmitters with integrated radiation shields
- ± 2 %RH accuracy
- Proven HUMICAP® 180R sensor for long-lasting accuracy
- 3-point traceable calibration (certificate included)
- Default output parameters are relative humidity and temperature. Dew point temperature, wet bulb temperature, and enthalpy outputs selectable with a PC connection
- Current output (4 ... 20 mA)
- On-site calibration with HM70 Hand-Held Meter or PC connection
- Ingress protection IP65

Vaisala HMS110 Series HUMICAP® Humidity and Temperature Transmitters are designed for demanding outdoor measurements in building automation applications. These ± 2 % transmitters include an integrated radiation shield to reduce the influence of solar radiation on temperature and humidity measurements.

Proven Vaisala HUMICAP® Performance for Outdoor Measurements

HMS110 transmitters are equipped with the trusted HUMICAP® 180R – a robust, general-purpose humidity sensor that functions well in high humidity. The sensor's superior stability ensures long-lasting accuracy and minimal maintenance throughout the transmitter's lifetime.

The integrated radiation shield allows unrivaled measurement performance, reducing the impact of sunshine on temperature and humidity measurements and ensuring measurement accuracy in outdoor conditions.

Easy Installation and Maintenance

HMS110 transmitters are easy to install. They can be mounted directly onto a wall or pole without any extra accessories. There are no loose parts, screws are retained in the enclosure, all connectors are clearly labeled, and the connectors are within easy reach.

The HUMICAP® sensor's excellent long-term stability and high-quality materials ensure minimal need for maintenance. If necessary, the transmitter can be field-calibrated using either HM70 Hand-Held Humidity and Temperature Meter, or a PC connection.

Technical Data

Models

Model	Type	Output	IP Rating
HMS110	Outdoor, RH+T	2-wire, current output	IP65
HMS112	Outdoor, RH+T	2-wire, current output	IP65

HMS110 is delivered with customer specific output settings, including calculated humidity parameters and special scaling of outputs.

Measurement Performance

Relative Humidity

Measurement range	0 ... 100 %RH
Stability in typical HVAC applications	±0.5 %RH/year
Humidity sensor	Vaisala HUMICAP® 180R

Accuracy at temperature range +10 ... +30 °C (+50 ... +86 °F):

0 ... 90 %RH	±2 %RH
90 ... 100 %RH	±3 %RH

Accuracy at temperature range -20 ... +10 °C, +30 ... +60 °C (-4 ... +50 °F, +86 ... +140 °F):

0 ... 90 %RH	±3 %RH
90 ... 100 %RH	±4 %RH

Accuracy at temperature range -40 ... -20 °C (-40 ... -4 °F):

0 ... 100%RH	±4 %RH
--------------	--------

Temperature

Measurement range	-40 ... +60 °C (-40 ... +140 °F)
Accuracy at +20 °C (+68 °F)	±0.2 °C (±0.36 °F)
Temperature dependence	±0.01 °C/°C
Temperature sensor	Pt1000 RTD Class F0.1 IEC 60751

Calculated Parameters

Factory calibration uncertainty at 20 °C (+68 °F)	±1.5 %RH/±0.2 °C
Measurement range for dew point temperature and wet bulb temperature	-40 ... +60 °C (-40 ... +140 °F)
Measurement range for enthalpy	-40 ... 460 kJ/kg (-10 ... +190 BTU/lb)
Accuracy of the calculated parameters should be calculated at the actual condition based on the RH and temperature specification.	
Accuracy at 20 °C (68 °F) and 80 %RH:	
Dew point	±0.7 °C (1.2 °F)
Wet bulb temperature	±0.5 °C (0.9 °F)
Enthalpy	±1.6 kJ/kg (0.7 BTU/lb)

Operating Environment

Operating temperature	-40 ... +60 °C (-40 ... +140 °F)
Operating humidity	0 ... 100 %RH
Maximum wind/flow speed	30 m/s (67 mph)
Storage temperature	-40 ... +60 °C (-40 ... +140 °F)
EMC compliance	EN61326-1, Industrial Environment

Inputs and Outputs

Analog outputs	4 ... 20 mA, loop powered
Loop resistance	0 ... 600 Ω
Supply voltage	20 ... 28VDC at 600 Ω load 10 ... 28VDC at 0 Ω load
Data input for RDP100 Remote Panel Display	RS-485 Vaisala proprietary protocol

Mechanical Specifications

Max. wire size	1.5 mm ² (AWG 16)
Standard housing color	White (RAL9003)
Housing material	PC + 10 %GF (UL-V0 approved)

Spare Parts and Accessories

Remote Panel Display	RDP100
Conduit fitting + O-ring (M16 × 1.5 / NPT1/2 Inch)	210675SP
Conduit fitting + O-ring (M16 × 1.5 / PG9, RE-MS)	210674SP
Fastening set HMS110	237805
Membrane Filter	ASM210856SP
Terminal Block, Blue	236620SP
USB cable for PC connection	219690
Connection cable for HM70 hand-held meter	219980SP
HUMICAP® 180R sensor	HUMICAP180R

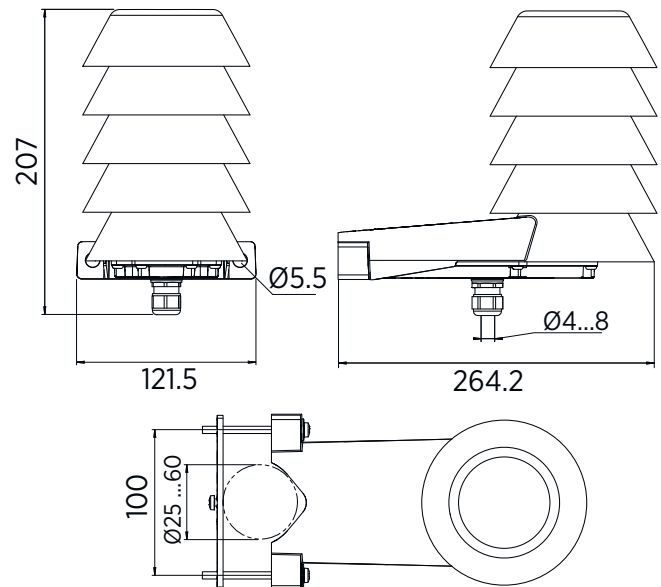



Features

- Reliable transmitters for basic HVAC humidity measurements
- ± 3.0 %RH accuracy
- Full 0 ... 100 %RH measurement range
- Optimized for easy installation and low maintenance
- User exchangeable INTERCAP® sensor for easy field replacement
- UL-V0 flammability rating
- Output parameters: relative humidity and temperature with optional dew point temperature, wet bulb temperature and enthalpy parameters

Vaisala HMDW80 Series INTERCAP® Humidity and Temperature Transmitters measure relative humidity and temperature in various building automation applications. HMDW80 series transmitters combine easy installation and reliable operation with a low requirement for maintenance.

Typical Installation Locations

- Ventilation ducts
- Walls
- Wash-down areas
- Outdoor locations

The versatile HMDW80 series includes transmitters for wall and duct mounting, IP65-classified transmitters for humid areas, and transmitters with a radiation shield for outdoor use. It also includes temperature-only transmitters and transmitters with an optional display.

Calculated humidity parameters – dew point temperature, wet bulb temperature, and enthalpy – are also available.

Easy Installation

HMDW80 series transmitters are optimized for easy installation. There are no loose parts, screws are retained in the enclosure, all connectors are clearly labeled, and the connectors are within easy reach.

The duct mount transmitters are well suited to a variety of duct sizes, the outdoor transmitters can be mounted directly onto a wall or pole without any

extra accessories, and the wall mount transmitters can be installed without the need to make holes in the transmitter enclosure.

Reliable Operation

HMDW80 series transmitters require minimal maintenance thanks to their excellent sensor stability and high-quality materials. If necessary, the INTERCAP® sensor can be easily exchanged in the field with minimum downtime.

Model number	Type	Output	Special Features	IP rating
TMW82	Wall-mount, T-only	2-wire, current output		IP30
TMW83	Wall-mount, T-only	3-wire, voltage output		IP30
HMW82	Wall-mount, RH+T	2-wire, current output		IP30
HMW82P100	Wall mount, RH+T	2-wire, current output	Additional Pt100 sensor	IP30
HMW83	Wall-mount, RH+T	3-wire, voltage output		IP30
TMW88	Wall-mount, T-only	2-wire, current output		IP65
HMW88	Wall-mount, RH+T	2-wire, current output	Calculated parameters ¹⁾	IP65
HMW88D	Wall-mount, RH+T	2-wire, current output	Display, calculated parameters ¹⁾	IP65
HMW89	Wall-mount, RH+T	3-wire, voltage output	Calculated parameters ¹⁾	IP65
HMW89D	Wall-mount, RH+T	3-wire, voltage output	Display, calculated parameters ¹⁾	IP65
TMD82	Duct-mount, T-only	2-wire, current output		IP65
TMD83	Duct-mount, T-only	3-wire, voltage output		IP65
HMD82	Duct-mount, RH+T	2-wire, current output	Calculated parameters ¹⁾	IP65
HMD82D	Duct-mount, RH+T	2-wire, current output	Display, calculated parameters ¹⁾	IP65
HMD83	Duct-mount, RH+T	3-wire, voltage output	Calculated parameters ¹⁾	IP65
HMD83D	Duct-mount, RH+T	3-wire, voltage output	Display, calculated parameters ¹⁾	IP65
HMS82	Outdoor, RH+T	2-wire, current output	Radiation shield, calculated parameters ¹⁾	IP65
HMS82C	Outdoor, RH+T	2-wire, current output	HMS82 with NPT ½" conduit fitting ¹⁾	IP65
HMS83	Outdoor, RH+T	3-wire, voltage output	Radiation shield, calculated parameters ¹⁾	IP65
HMS83C	Outdoor, RH+T	3-wire, voltage output	HMS83 with NPT ½" conduit fitting ¹⁾	IP65

1) Output parameters for humidity: relative humidity, dew point temperature, wet bulb temperature, and enthalpy.

Dimensions

HMW82/83 RH+T and TMW82/83 T-only transmitters for wall-mounting

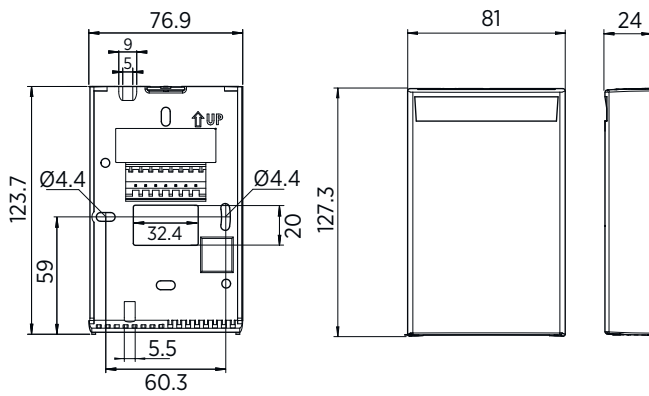

HMS82/83 RH+T transmitters for outdoor measurements

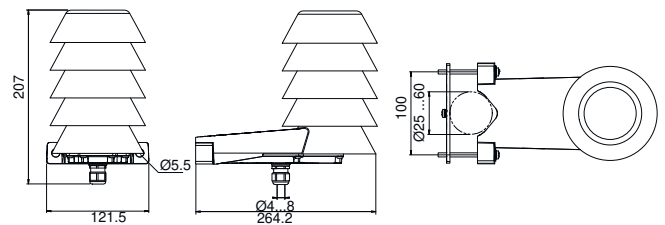

HMW88/89(D) and TMW88 RH+T transmitters for measurements in wet areas

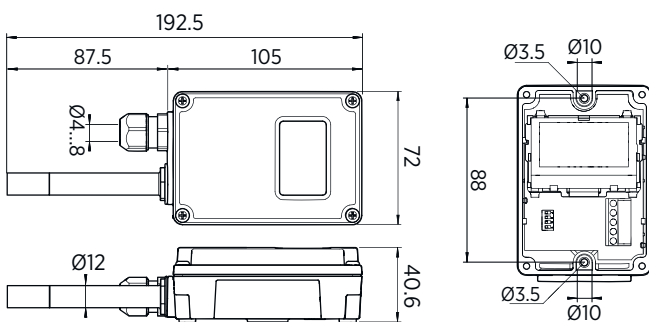

HMD82/83(D) and TMD82/83 RH+T and T-only transmitters for ducts

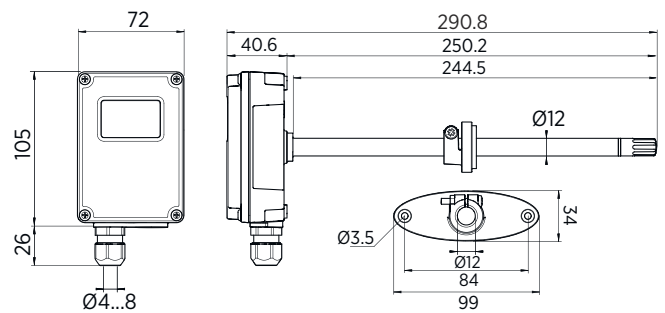

Technical Data

Measurement Performance, Models HMW82/83 and TMW82/83

Relative Humidity	
Measurement range	0 ... 100 %RH
Accuracy in temperature range +10 ... +30 °C (+50 ... +86 °F)	±3 %RH (0 ... 70 %RH) ±5 %RH (70 ... 100 %RH)
Accuracy in temperature range -5 ... +10 °C, +30 ... +55 °C (+23 ... +50 °F, +86 ... +131 °F)	±7 %RH (0 ... 100 %RH)
Stability in typical HVAC applications	±2 %RH over 2 years
Humidity sensor	Vaisala INTERCAP®
Temperature	
Measurement range	-5 ... +55 °C (+23 ... +131 °F)
Accuracy at +10 ... +30 °C (+50 °F ... +86 °F)	±0.5 °C (±0.9 °F)
Accuracy at -5 ... +10 °C, +30 ... +55 °C (+23 ... +50 °F, +86 ... +131 °F)	±1.0 °C (±1.8 °F)
Temperature sensor	Digital temperature sensor
Temperature sensor HMW82P100	Pt100 Class F 0.1 IEC 60751, 3-wire connection

Measurement Performance, Models HMD82/83, TMD82/83, HMW88/89, TMW88 and HMS82/83

Relative Humidity	
Measurement range	0 ... 100 %RH
Accuracy in temperature range +10 ... +30 °C (+50 ... +86 °F)	±3 %RH (0 ... 90 %RH) ±5 %RH (90 ... 100 %RH)
Accuracy in temperature range -20 ... +10 °C, +30 ... +60 °C (-4 ... +50 °F, +86 ... +140 °F)	±5 %RH (0 ... 90 %RH) ±7 %RH (90 ... 100 %RH)
Accuracy in temperature range -40 ... -20 °C (-40 ... -4 °F)	±7 %RH (0 ... 100 %RH)
Stability in typical HVAC applications	±2 %RH over 2 years
Humidity sensor	Vaisala INTERCAP®
Temperature	
Measurement range	-40 ... +60 °C (-40 ... +140 °F)
Accuracy at +20 °C (+68 °F)	±0.3 °C (±0.54 °F)
Temperature dependence	±0.01 °C/ °C
Temperature sensor	Pt1000 RTD Class F0.1 IEC 60751
Calculated Parameters	
Measurement range for dew point temperature and wet bulb temperature	-40 ... +60 °C (-40 ... +140 °F)
Measurement range for enthalpy	-40 ... 460 kJ/kg (-10 ... +190 BTU/lb)

Operating Environment

Maximum wind/flow speed	30 m/s
Storage temperature	-40 ... +60 °C (-40 ... +140 °F)
EMC compliance	EN61326-1, Industrial Environment
Operating Temperature	
HMW82/83 and TMW82/83	-5 ... +55 °C (+23 ... +131 °F)
HMD82/83, TMD82/83, HMW88/89, TMW88 and HMS82/83	-40 ... +60 °C (-40 ... +140 °F)
HMD82/83D and HMW88/89D	-5 ... +60 °C (+23 ... +140 °F)
Operating Humidity	
HMD82/83, TMD82/83, HMW88/89, TMW88 and HMS82/83	0 ... 100 %RH
HMW82/83, TMW82/83, HMD82/83D and HMW88/89D	0 ... 100 %RH, non-condensing

Measurement Performance, Models HMD82/83D and HMW88/89D

Relative Humidity	
Measurement range	0 ... 100 %RH
Accuracy in temperature range +10 ... +30 °C (+50 ... +86 °F)	±3 %RH (0 ... 90 %RH) ±5 %RH (90 ... 100 %RH)
Accuracy in temperature range -5 ... +10 °C, +30 ... +60 °C (+23 ... +50 °F, +86 ... +140 °F)	±5 %RH (0 ... 90 %RH) ±7 %RH (90 ... 100 %RH)
Stability in typical HVAC applications	±2 %RH over 2 years
Humidity sensor	Vaisala INTERCAP®
Temperature	
Measurement range	(Analog output scaling) -40 ... +60 °C (-40 ... +140 °F)
Accuracy at +20 °C (+68 °F)	±0.3 °C (±0.54 °F)
Temperature dependence	±0.01 °C/ °C
Temperature sensor	Pt1000 RTD Class F0.1 IEC 60751
Calculated Parameters	
Measurement range for dew point temperature and wet bulb temperature	-40 ... +60 °C (-40 ... +140 °F)
Measurement range for enthalpy	-40 ... 460 kJ/kg (-10 ... +190 BTU/lb)

Inputs and Outputs

Current output models (2-wire)	
Outputs	4 ... 20 mA, loop powered
Loop resistance	0 ... 600 Ω
Supply voltage	20 ... 28 VDC at 600 Ω load 10 ... 28 VDC at 0 Ω load
Voltage output models (3-wire)	
Outputs	0 ... 10 V
Load resistance	10 kΩ min
Supply voltage	18 ... 35 VDC 24 VAC ±20 % 50/60 Hz

Mechanical Specifications

Max wire size	1.5 mm ² (AWG 16)
Standard housing color	White (RAL9003)
Housing material	
HMW82/83, TMW82/83	ABS/PC (UL-V0 approved)
HMW88/89(D), HMD82/83(D), TMW88, TMD82/83, HMS82/83	PC + 10 %GF (UL-V0 approved)

Spare Parts and Accessories

INTERCAP sensor	15778HM
10 pcs of INTERCAP sensors	INTERCAPSET-10PCS
Conduit fitting + O-ring (M16x1.5 / NPT1/2 Inch)	210675SP
Conduit fitting + O-ring (M16x1.5 / PG9, RE-MS)	210674SP
Fastening set HMS80	237805
Porous PTFE Filter	DRW239993SP
Membrane Filter	ASM210856SP
Terminal Block, Blue	236620SP
HMD80 display lid	ASM210793SP

VAISALA

www.vaisala.com



HMS80 Series Humidity and Temperature Transmitters

For Outdoor Measurements in Building Automation Applications



Features

- Reliable outdoor transmitters with integrated radiation shields
- ± 3 %RH accuracy
- User-exchangeable INTERCAP® sensor for easy field replacement
- Default output parameters are relative humidity and temperature. Dew point temperature, wet bulb temperature, and enthalpy outputs selectable using DIP switches
- Options for both current and voltage outputs
- Ingress protection IP65

Vaisala HMS80 Series INTERCAP® Humidity and Temperature Transmitters are designed for outdoor measurements in various building automation applications. These ± 3 % transmitters include an integrated radiation shield to reduce the influence of solar radiation on temperature and humidity measurements.

Easy Installation

HMS80 transmitters are easy to install. They can be mounted directly onto a wall or pole without any extra accessories. There are no loose parts, screws are retained in the enclosure, all connectors are clearly labeled, and the connectors are within easy reach.

For fast and convenient configuration, the most popular control parameters in free cooling control – dew point temperature, wet bulb temperature, and enthalpy – are selectable using DIP switches.

Low Maintenance

HMS80 series transmitters require minimal maintenance thanks to their excellent sensor stability and high-quality materials. If necessary, the INTERCAP® sensor can easily be replaced in the field with minimum downtime.

Technical Data

Models

Model	Type	Output	IP Rating
HMS82	Outdoor, RH+T	2-wire, current output	IP65
HMS83	Outdoor, RH+T	3-wire, voltage output	IP65

Measurement Performance

Relative Humidity

Measurement range	0 ... 100 %RH
Accuracy at temperature range +10 ... +30 °C (+50 ... +86 °F):	
0 ... 90 %RH	±3 %RH
90 ... 100 %RH	±5 %RH
Accuracy at temperature range -20 ... +10 °C, +30 ... +60 °C: (-4 ... +50 °F, +86 ... +140 °F)	
0 ... 90 %RH	±5 %RH
90 ... 100 %RH	±7 %RH
Accuracy in temperature range -40 ... -20 °C (-40 ... -4 °F):	
0 ... 100 %RH	±7 %RH
Stability in typical HVAC applications	±2 %RH over 2 years
Humidity sensor	Vaisala INTERCAP®

Temperature

Measurement range	-40 ... +60 °C (-40 ... +140 °F)
Accuracy at +20 °C (+68 °F)	±0.3 °C (±0.54 °F)
Temperature dependence	±0.01 °C/°C
Temperature sensor	Pt1000 RTD Class F0.1 IEC 60751

Calculated Parameters ¹⁾

Measurement range for dew point temperature and wet bulb temperature	-40 ... +60 °C (-40 ... +140 °F)
Measurement range for enthalpy	-40 ... 460 kJ/kg (-10 ... +190 BTU/lb)
Accuracy at 20 °C (68 °F) and 80 %RH	Dew point: ±0.9 °C (1.6 °F) Wet bulb temperature: ±0.7 °C (1.3 °F) Enthalpy: ±2 kJ/kg (0.9 BTU/lb)

¹⁾ Accuracy of the calculated parameters should be calculated at the actual condition based on the relative humidity and temperature specification.

Inputs and Outputs

Current Output Model HMS82 (2-wire)

Outputs	4 ... 20 mA, loop powered
Loop resistance	0 ... 600 Ω
Supply voltage	20 ... 28 VDC at 600 Ω load 10 ... 28 VDC at 0 Ω load

Voltage Output Model HMS83 (3-wire)

Outputs	0 ... 10 V
Load resistance	10 kΩ min
Supply voltage	18 ... 35 VDC 24 VAC ±20 % 50/60 Hz

Operating Environment

Operating temperature	-40 ... +60 °C (-40 ... +140 °F)
Operating humidity	0 ... 100 %RH
Maximum wind/flow speed	30 m/s (67 mph)
Storage temperature	-40 ... +60 °C (-40 ... +140 °F)
EMC compliance	EN61326-1, Industrial Environment

Mechanical Specifications

Max. wire size	1.5 mm ² (AWG 16)
Standard housing color	White (RAL9003)
Housing material	PC + 10 %GF (UL-V0 approved)

Spare Parts and Accessories

INTERCAP® sensor	15778HM
10 pcs of INTERCAP® sensors	INTERCAPSET-10PCS
Conduit fitting + O-ring (M16 × 1.5 / NPT1/2 Inch)	210675SP
Conduit fitting + O-ring (M16 × 1.5 / PG9, RE-MS)	210674SP
Fastening set HMS80	237805
Membrane Filter	ASM210856SP
Terminal Block, Blue	236620SP

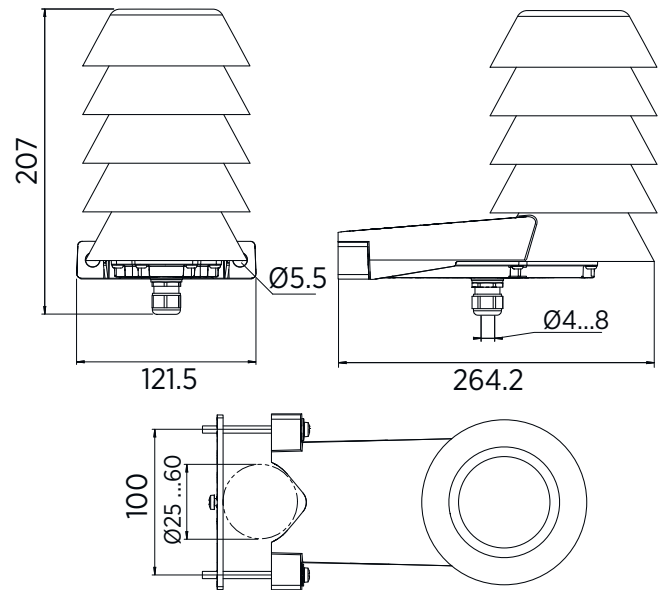

Dimensions in mm

VAISALA

www.vaisala.com

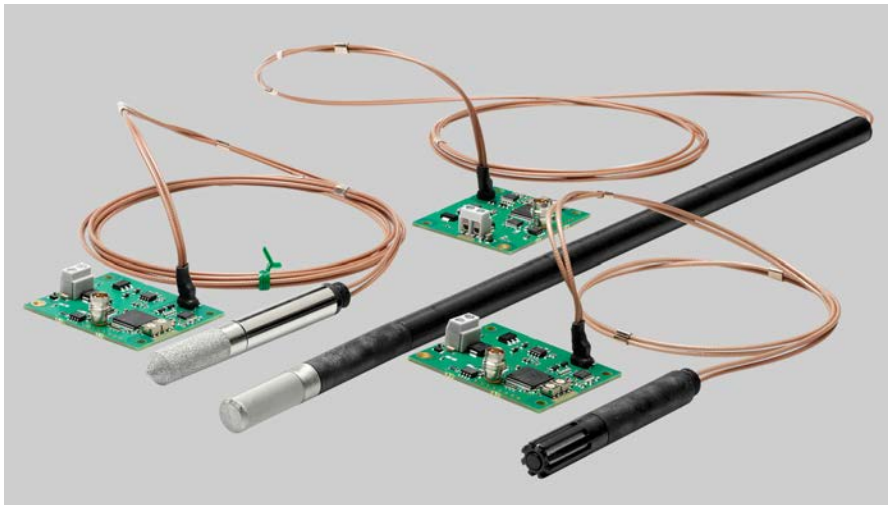

Features

- Full temperature compensation over the operating temperature range of -70 °C ... +180 °C (-94 °F ... +356 °F)
- High temperature tolerance, also suitable for heat sterilization
- Vaisala HUMICAP® R2 sensor
- Easy field calibration by trimmers
- Applications: test chambers, incubators

Vaisala HUMICAP® Humidity Module HMM100 is an open frame module for integration into environmental chambers. The modules provide a single analog output channel for relative humidity (RH) or dew point (T_d).

Benefits

- Excellent measurement accuracy
- Low-maintenance
- Easy to install
- Durable

Two types of probes are available, one made of stainless steel, the other of plastics. The plastic probe comes in two sizes, a standard one and an extended 400-mm-long option. Several cable lengths up to 3 meters are available. Both probes use the Vaisala HUMICAP® R2 sensor which ensures excellent measurement accuracy.

Robust and Reliable

The HMM100 probe works in freezing conditions (-70 °C (-94 °F)) and also in temperatures up to +180 °C (+356 °F). HMM100 is easy to install and the probe can be freely placed in a test chamber as the speed of airflow does not affect the measurement.

Low-maintenance

Compared to psychrometers, HMM100 requires very little maintenance. There is no wick that needs changing and there is no need for a water tank or water pump. Thus, environmental stress screening can be done reliably.

Accessories

The accessories available are a component board mounting bracket with a lid, probe clamp, USB cable for service use, a module housing, and a probe mounting flange.

Technical Data

Measurement Performance

Relative Humidity

Measurement range	0 ... 100 %RH
Factory calibration uncertainty (+20 °C / +68 °F)	±1.5 %RH
Humidity sensor types	Vaisala HUMICAP® R2 Vaisala HUMICAP® 180V

Accuracy at -20 ... +40 °C (-4 ... +104 °F) (Incl. Non-Linearity, Hysteresis and Repeatability):

0 ... 90 %RH	±2 %RH
90 ... 100 %RH	±3 %RH

Accuracy at -40 ... -20 °C and +40 ... +180 °C (-40 ... -4 °F and +104 ... +356 °F) (Incl. Non-Linearity, Hysteresis and Repeatability):

0 ... 90 %RH	±2.5 %RH
90 ... 100 %RH	±3.5 %RH

Dew Point Temperature

Measurement range	-20 ... +100 °C (-4 ... +212 °F) T _d
-------------------	---

Accuracy (incl. non-linearity, hysteresis and repeatability) when dew point depression <20 °C (+68 °F) (Ambient temperature - dew point)

Operating Environment

EMC compliance	Applicable parts of EN61326-1, Generic Environment
----------------	---

Operating Temperature

Component board	-5 ... +55 °C (+23 ... +131 °F)
Stainless steel probe	-70 ... +180 °C (-94 ... +356 °F)
Plastic probe (standard body)	-70 ... +180 °C (-94 ... +356 °F)
Plastic probe (extended 400-mm (16-in) body)	-70 ... +120 °C (-94 ... +248 °F)
Plastic grid and membrane filter	-20 ... +80 °C (-4 ... +176 °F)
Porous PTFE, stainless steel sintered, and PPS plastic grid with stainless steel net filter	-70 ... +180 °C (-94 ... +356 °F)

Mechanical Specifications

Service cable connector	M8 series 4-pin (male)
Probe diameter	12 mm (0.5 in)

Probe Cable Lengths

Stainless steel probe	1.55/2.9 m (5.1/9.5 ft)
Plastic probe (standard body)	0.6/1.55/2.9 m (2/5.1/9.5 ft)
Plastic probe (extended 400-mm (16 in) body)	1.55 m (5.1 ft)

Probe Material

Stainless steel probe	AISI316/PPS
Plastic probe	PPS
Extension tube for 400-mm probe	POM
Probe mounting clamp	AISI316

Mounting Bracket Material

Lid	ABS/PC
Bottom plate	Al
Module housing material	ABS/PC (cover)

Inputs and Outputs

Power consumption	6 mA
-------------------	------

Operating Voltage

2-wire model	24 VDC
3-wire model	10 ... 35 VDC or 24 VAC ±20 % 15 ... 35 VDC or 24 VAC ±20 % when 0 ... 10 V output is used

Analog Output Types (1 Output Selectable)

2-wire model	4 ... 20 mA (loop-powered)
3-wire model	0 ... 20 mA, 0 ... 1/5/10 V
Max. wire size	0.5 ... 1.5 mm ² (AWG)
Service port	M8 connector for USB cable

Spare Parts and Accessories

Humidity sensor	HUMICAPR2
Humidity sensor	HUMICAP180R
Humidity sensor	HUMICAP180V
Plastic grid filter	6221
Membrane filter	10159HM
Porous PTFE filter	219452SP
Stainless steel sintered filter	HM47280SP
PPS plastic grid with stainless steel net filter	DRW010281SP
Mounting bracket with lid	225979
Module housing (IP65)	226060
Probe mounting flange	226061
Probe mounting clamp set (10 pcs)	226067
USB cable	226068

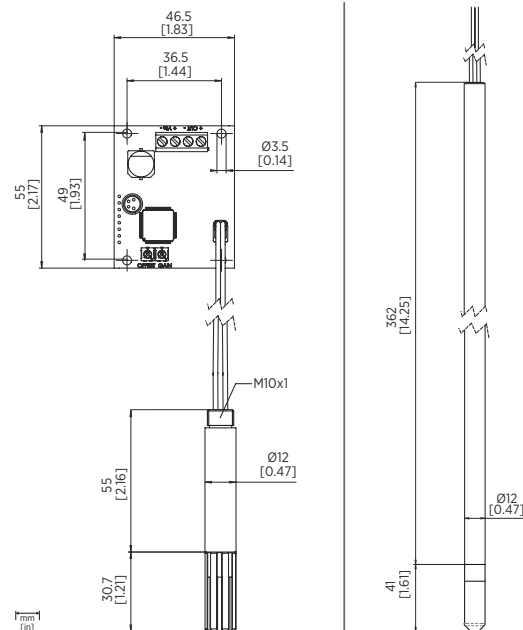

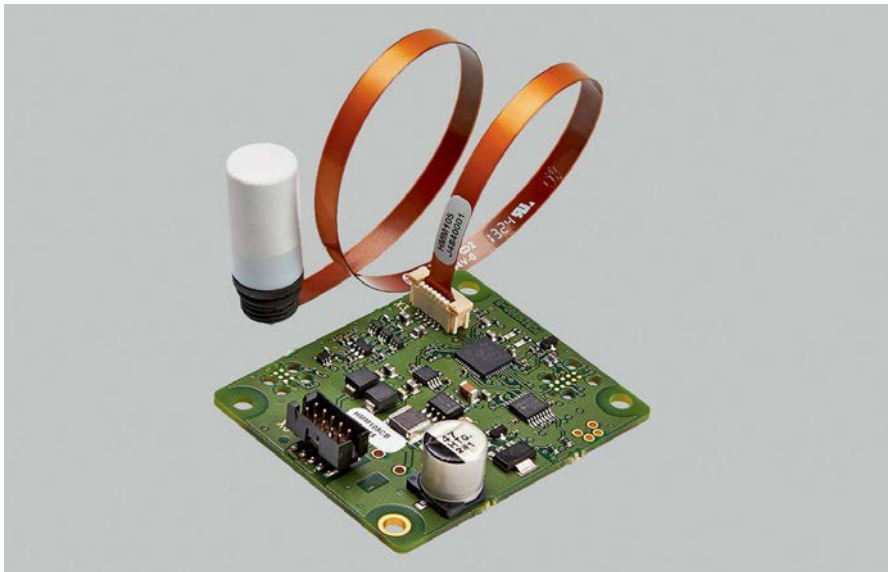

Features

- Digital I²C communication interface available
- Full temperature compensation over the operating temperature range of -40 °C ... +180 °C
- High temperature tolerance, suitable for heat sterilization up to +200 °C
- Vaisala HUMICAP[®] 180R sensor
- Detachable probe assembly
- Probe head with M10x1 threads
- Applications: test chambers, incubators

Vaisala HUMICAP[®] Digital Humidity Module HMM105 is an open frame module for integration into environmental chambers. The modules provide an I²C output for relative humidity (RH) or dew point (T_d).

Benefits

- Easy installation
- Excellent measurement accuracy
- Maintenance-free

The module consists of a detachable probe assembly – a probe head with M10x1 threads and a flex cable – and the module circuit board. The probe assembly is 30 cm in length. The module incorporates the Vaisala HUMICAP[®] 180R sensor which ensures excellent measurement accuracy.

Reliable for OEM's

The HMM105 probe head works in freezing conditions (-40 °C) and also in temperatures up to +180 °C in continuous use. In short term use, the probe head can be exposed to temperatures up to +200 °C. HMM105 is intended for OEM chamber manufacturers for integration into test chambers and incubators.

Maintenance-free

Compared to psychrometers, HMM105 is practically maintenance free. There is no wick that needs changing and there is no need for a water tank or water pump. Thus, environmental stress screening can be done reliably.

I²C interface for better usability

HMM105 has an I²C interface for communicating with the incubator's controller. HMM105 implements I²C slave functionality, with the incubator's controller acting as the master. The interface can be used to read measurement values and status information, set operation parameters, and make adjustments.

Technical Data

Relative Humidity

Measurement range	0 ... 100 %RH
Factory calibration uncertainty (+20 °C)	±1.5 %RH
Humidity sensor	Vaisala HUMICAP® 180R
Accuracy (incl. Non-Linearity, Hysteresis and Repeatability)	
Temperature	-20 ... +40 °C
0 ... 90 %RH	±2 %RH
90 ... 100 %RH	±3 %RH
Temperature	-40 ... -20 °C, +40 ... +180 °C
0 ... 90 %RH	±2.5 %RH
90 ... 100 %RH	±3.5 %RH

Dew Point Temperature

Measurement range	-20 ... +100 °C (-4 ... +212 °F) _{T_d}
Accuracy (incl. non-linearity, hysteresis and repeatability) when dew point depression < 20 °C (Ambient temperature - dew point)	±2 °C T _d

Operating Environment

EMC compliance	Applicable parts of EN61326-1, Industrial Environment
Storage temperature	-40 ... +75 °C (-40 ... +167 °F)
Operating Temperature	
Component board	-5 ... +55 °C (+23 ... +131 °F)
Probe (continuous use)	-40 ... +180 °C (-40 ... +356 °F)
Probe (short term peak)	+200 °C (+392 °F)
Plastic grid, membrane filter	-20 ... +80 °C (-4 ... +176 °F)
PTFE sintered filters, stainless steel sintered filter	-40 ... +200 °C (-40 ... +392 °F)

Inputs and Outputs

Supply voltage	10 ... 35 VDC, 24 VAC (±20 %)
Output voltage	I ² C 5 V
Power consumption (DC/AC)	< 15/25 mA
Connector for supply voltage and I ² C bus	Molex 87832-1007, 10-pin header bus

Mechanical Specifications

Probe diameter	12 mm
Probe flex cable length	0.3 m
Probe lead-through material	PPS plastic

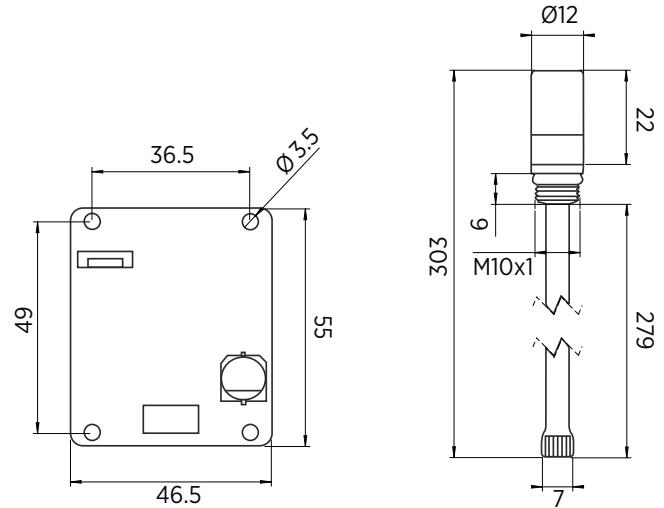

Dimensions in millimeters

Spare Parts and Accessories

Humidity sensor	HUMICAP® 180R
Short PTFE sintered filter	DRW239993SP
Plastic grid filter	6221
Plastic grid and membrane filter	10159HM
PTFE sintered filter	219452SP
Stainless steel sintered filter	HM47280SP
0.6 m cable with Molex milli-grid connectors	ASM210962SP



Features

- Miniature-size humidity probe
- Low power consumption
- Measurement range: 0 ... 100 %RH; -40 ... +60 °C
- Cable detachable with standard M8 connector
- Rugged metal housing
- Interchangeable Vaisala INTERCAP® Sensor
- Optional RS-485 digital output supports Modbus RTU
- Optional dew point output

HMP60 is a simple, durable and cost-effective humidity probe. It is suitable for volume applications, integration into other manufacturers' equipment, incubators, glove boxes, greenhouses, fermentation chambers, and data loggers.

Easy Installation

The probe cable has a screw-on quick connector for easy installation. Different cable lengths are available. Also other compatible M8 series cables can be used. Accessories are available for different installation needs.

Low Current Consumption

HMP60 is suitable for battery-powered applications because of its very low current consumption.

Several Outputs

There are two configurable voltage outputs with relative humidity, temperature or dew point scaling. Four voltage output ranges are available. An optional RS-485 output with Modbus support is also available.

Rugged Design

HMP60 is designed for extreme conditions. The stainless steel body of HMP60 is classified as IP65. The probe has a sealed structure and the sensor is protected by a membrane filter and a plastic grid, or optionally by a stainless steel filter.

Recalibration Not Needed

The Vaisala INTERCAP® Sensor is interchangeable. No recalibration is required; the sensor can simply be replaced, also in the field.

Technical Data

Measurement Performance

Relative Humidity

Measurement range	0 ... 100 %RH
Typical Accuracy:	
Temperature range	0 ... +40 °C
0 ... 90 %RH	±3 %RH
90 ... 100 %RH	±5 %RH
Temperature range	-40 ... 0 °C, +40 ... +60 °C
0 ... 90 %RH	±5 %RH
90 ... 100 %RH	±7 %RH
Humidity sensor	Vaisala INTERCAP®

Temperature

Measurement range	-40 ... +60 °C
Accuracy over Temperature Range:	
+10 ... +30 °C	±0.5 °C
-40 ... +10, +30 ... +60 °C	±0.6 °C

Dew Point

Measurement range	-40 ... +60 °C
Typical Accuracy:	
Temperature range	0 ... +40 °C
When dew point depression ¹ < 15 °C	±2 °C
Temperature range	-40 ... 0 °C, +40 ... +60 °C
When dew point depression < 10 °C ¹⁾	±3 °C

Analog Outputs

Accuracy at 20 °C	±0.2 % of FS
Temperature dependence	±0.01 % of FS/°C

¹⁾ Dew point depression = ambient temperature - dew point

Operating Environment

Operating temperature	-40 ... +60 °C
EMC compliance	EN 61326-1, industrial environment

Mechanical Specifications

IP rating	IP65
Body thread	M12x1 / 10 mm
Cable connector	4-pin M8 (IEC 60947-5-2)
Materials	
Body	Stainless steel (AISI 316)
Grid filter	Chrome coated ABS plastic
Cable	Polyurethane or FEP
Weight	
Probe	17 g
Probe with 0.3 m cable	28 g

Inputs and Outputs

Power consumption 1 mA average, max. peak 5 mA

Operating Voltage¹⁾

With 1 V / 2.5 V output	5 ... 28 VDC
With 5 V output	8 ... 28 VDC
With loop power converter	8 ... 28 VDC
With digital output	5 ... 20 VDC

Start-Up Time

Probes with analog output	4 s at operating voltage 13.5 ... 16.5 VDC 2 s at other valid operating voltages
Probes with digital output	1 s

Outputs

2 channels	0 ... 1 VDC / 0 ... 2.5 VDC / 0 ... 5 VDC / 1 ... 5 VDC
1-channel loop-power converter (separate module, compatible with humidity accuracy only)	4 ... 20 mA
Digital output (optional)	RS-485 2-wire half duplex, supports Modbus RTU

External Loads

0 ... 1 V	R _L min. 10 kΩ
0 ... 2.5 V / 0 ... 5 V	R _L min. 50 kΩ

¹⁾ (Use Lowest Available Operating Voltage to Minimize Heating)

Spare Parts and Accessories

Vaisala INTERCAP® Sensor, 1 piece	15778HM
Vaisala INTERCAP® Sensor, 10 pcs	INTERCAPSET-10PCS
4 ... 20mA loop power converter	UI-CONVERTER-1CB
Mounting bracket for converter	225979
Plastic M12 installation nuts, pair	18350SP
USB cable for PC connection	219690
Probe mounting clamp set, 10 pcs	226067
Probe mounting flange	226061

Sensor Protection

Plastic grid	DRW010522
Membrane filter	DRW010525
Stainless steel sintered filter	HM46670SP
PTFE sintered filter	DRW244938SP

Connection Cables

0.3 m PU	HMP50Z032SP
3 m PU	HMP50Z300SP
180 °C 3 m FEP	226902SP

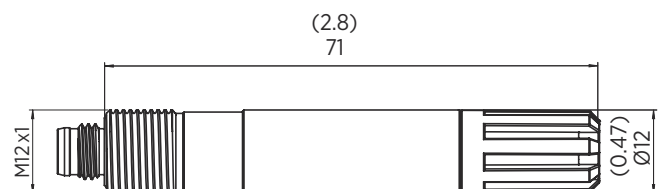

Dimensions in mm (inches)



Features

- Fast thermal response time
- Low power consumption
- Start-up time < 2 s
- Measurement range: 0 ... 100 %RH; -40 ... +60 °C
- Detachable cable with standard 4-pin M8 connector
- Plastic enclosure with IP54 classification
- Interchangeable Vaisala INTERCAP® sensor
- Optional RS-485 digital output
- Optional dew point output

Vaisala INTERCAP® Humidity and Temperature Probe HMP63 is a cost-effective humidity probe with plastic enclosure. It is designed for noncondensing indoor environments or integration into other manufacturers' equipment.

Easy Installation

The probe fits into tight spaces. The cable has a threaded M8 connector for easy installation. Different cable lengths are available and other compatible M8-series cables can also be used.

Accessories are available for different installation needs.

Low Power Consumption

HMP63 is suitable for battery powered applications thanks to its very low power consumption and fast start-up time.

Several Outputs

There are two configurable voltage outputs for relative humidity, temperature, or dew point output. An alternative RS-485 output with Modbus support is also available.

Fast Thermal Response Time

HMP63 has a PC/ABS plastic enclosure. It is ideal for conditions with fast temperature changes and when standard measurement accuracy is sufficient.

No Recalibration Required

HMP63 includes an interchangeable Vaisala INTERCAP® sensor. No recalibration is required – the humidity sensor can simply be replaced, even in the field.

Technical Data

Measurement Performance

Relative Humidity

Measurement range	0 ... 100 %RH
Typical Accuracy:	
Temperature range	0 ... +40 °C
0 ... 90 %RH	±3 %RH
90 ... 100 %RH	±5 %RH
Temperature range	-40 ... 0 °C, +40 ... +60 °C
0 ... 90 %RH	±5 %RH
90 ... 100 %RH	±7 %RH
Humidity sensor	Vaisala INTERCAP®

Temperature

Measurement range	-40 ... +60 °C
Accuracy over Temperature Range:	
+10 ... +30 °C	±0.5 °C
-40 ... +10, +30 ... +60 °C	±0.6 °C

Dew Point

Measurement range	-40 ... +60 °C
Typical Accuracy:	
Temperature range	0 ... +40 °C
When dew point depression ¹ < 15 °C	±2 °C
Temperature range	-40 ... 0 °C, +40 ... +60 °C
When dew point depression < 10 °C ¹⁾	±3 °C

Analog Outputs

Accuracy at 20 °C	±0.2 % of FS
Temperature dependence	±0.01 % of FS/°C

Inputs and Outputs

Power consumption	1 mA average, max. peak 5 mA
-------------------	------------------------------

Operating Voltage¹⁾

With 1 V / 2.5 V output	5 ... 28 VDC
With 5 V output	8 ... 28 VDC
With loop power converter	8 ... 28 VDC
With digital output	5 ... 20 VDC

Start-Up Time

Probes with analog output	4 s at operating voltage
	13.5 ... 16.5 VDC
Probes with digital output	2 s at other valid operating voltages
	1 s

Outputs

2 channels	0 ... 1 VDC / 0 ... 2.5 VDC / 0 ... 5 VDC / 1 ... 5 VDC
1-channel loop-power converter (separate module, compatible with humidity accuracy only)	4 ... 20 mA
Digital output (optional)	RS-485 2-wire half duplex

External Loads

0 ... 1 V	R _L min. 10 kΩ
0 ... 2.5 V / 0 ... 5 V	R _L min. 50 kΩ

¹⁾ (Use Lowest Available Operating Voltage to Minimize Heating)

Operating Environment

Operating temperature	-40 ... +60 °C
EMC compliance	EN 61326-1, basic immunity test requirements

Mechanical Specifications

IP rating	IP54
Cable connector	4-pin M8 (IEC 60947-5-2)
Materials	
Body	PC/ABS blend
Grid filter	PC (glass reinforced)
Cable	Polyurethane or FEP
Weight	
Probe	9 g
Probe with 0.3 m cable	20 g

Spare Parts and Accessories

Vaisala INTERCAP® Sensor, 1 piece	15778HM
Vaisala INTERCAP® Sensor, 10 pcs	INTERCAPSET-10PCS
4 ... 20mA loop power converter	UI-CONVERTER-1CB
Mounting bracket for converter	225979
Plastic M12 installation nuts, pair	18350SP
USB cable for PC connection	219690
Probe mounting clamp set, 10 pcs	226067
Probe mounting flange	226061

Sensor Protection

Plastic grid for use with HM40	DRW236214SP
Membrane filter	230727SP
Stainless steel sintered filter	HM47280SP
Porous PTFE filter	219452SP

Connection Cables

0.3 m PU	HMP50Z032SP
3 m PU	HMP50Z300SP
180 °C 3 m FEP	226902SP

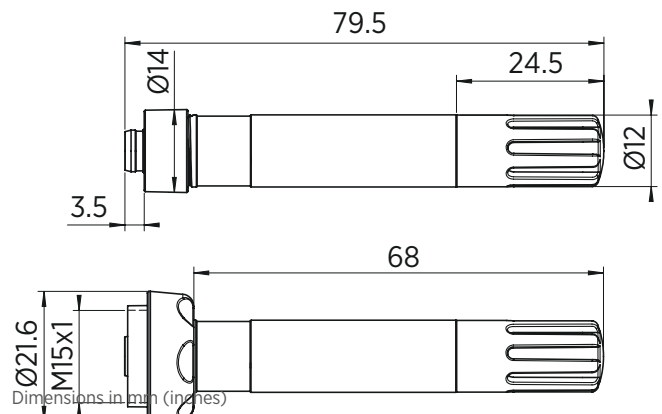



Features

- Miniature-size humidity transmitter
- Low power consumption and fast start-up for battery-powered applications
- Measurement range: 0 ... 100 %RH; -40 ... +80 °C (-40 ... +176 °F)
- Cable detachable with standard M8 quick connector
- IP65 metal housing
- Optional RS-485 digital output supports Modbus RTU
- ±1.5 %RH measurement accuracy (0 ... 90 %RH)

HMP110 is a trouble-free and cost-effective humidity transmitter with high accuracy and good stability. It is suitable for volume applications or integration into other manufacturers' equipment. HMP110 is also suitable for glove boxes, greenhouses, fermentation and stability chambers, data loggers, and incubators.

Benefits

- Latest generation Vaisala HUMICAP® 180R sensor for best stability and high chemical tolerance
- HMP110R replacement probe service available for easy maintenance
- Comes with calibration certificate
- Optional dew point calculation

Easy Installation

The probe cable has a screw-on quick connector for easy installation. Different cable lengths and accessories are available.

Low Current Consumption

HMP110 is suitable for battery-powered applications because of its very low current consumption. It also has a fast start-up time.

Several Outputs

The temperature measurement is a standard feature, dew point measurement is optional. Three standard voltage outputs are available. An optional RS-485 output with Modbus support is also available.

Robust Design

The stainless steel body of HMP110 is classified as IP65. Thus, it survives rough conditions. HMP110 has high chemical tolerance thanks to the HUMICAP® 180R sensor.

Easy Maintenance

Maintaining measurement traceability is easy using the HMP110R replacement probe. We send you a replacement probe, you detach the old probe and send it back to us. This way the measurement is available at all times without interruptions.

Technical Data

Measurement Performance

Relative Humidity

Measurement range	0 ... 100 %RH
Accuracy at 0 ... +40 °C (+32 ... +104 °F) (Incl. Non-Linearity, Hysteresis and Repeatability):	
0 ... 90 %RH	±1.5 %RH
90 ... 100 %RH	±2.5 %RH
Accuracy at -40 ... 0 °C, +40 ... +80 °C (-40 ... +32 °F, +104 ... +176 °F) (Incl. Non-Linearity, Hysteresis and Repeatability):	
0 ... 90 %RH	±3.0 %RH
90 ... 100 %RH	±4.0 %RH
Factory Calibration Uncertainty (+20 °C (+68 °F)):	
0 ... 90 %RH	±1.1 %RH
90 ... 100 %RH	±1.8 %RH
Humidity sensor	Vaisala HUMICAP® 180R
Stability	±2 %RH over 2 years

Temperature

Measurement range	-40 ... +80 °C (-40 ... +176 °F)
Accuracy over Temperature Range (Probes with Analog Output):	
0 ... +40 °C (+32 ... +104 °F)	±0.2 °C (±0.36 °F)
-40 ... 0 °C, +40 ... +80 °C (-40 ... +32 °F, +104 ... +176 °F)	±0.4 °C (±0.72 °F)
Accuracy over Temperature Range (Probes with Digital Output):	
+15 ... +25 °C (+59 ... +77 °F)	±0.1 °C (±0.18 °F)
0 ... +15 °C, +25 ... +40 °C (+32 ... +59 °F, +77 ... +104 °F)	±0.15 °C (±0.27 °F)
-40 ... 0 °C, +40 ... +80 °C (-40 ... +32 °F, +104 ... +176 °F)	±0.4 °C (±0.72 °F)
Temperature sensor	Pt1000 RTD Class F0.1 IEC 60751

Dew Point

Measurement range	-40 ... +80 °C (-40 ... +176 °F)
Accuracy at 0 ... +40 °C (+32 ... +104 °F) (Incl. Non-Linearity, Hysteresis and Repeatability):	
When dew point depression < +15 °C (+59 °C)	±1 °C (±33.8 °F)
When dew point depression +15 ... +25 °C (+59 ... +77 °F)	±2 °C (±35.6 °F)
Accuracy at -40 ... 0 °C, +40 ... +80 °C (-40 ... +32 °F, +104 ... +176 °F) (Incl. Non-Linearity, Hysteresis and Repeatability):	
When dew point depression < +15 °C (+59 °F) ¹⁾	±2 °C (±35.6 °F)

Analog Outputs

Accuracy at +20 °C (+68 °F)	±0.2 % of FS
Temperature dependence	±0.01 % of FS/°C (±0.006 % of FS/°F)

¹⁾ Dew point depression = ambient temperature - dew point

Mechanical Specifications

IP rating	IP65
Body thread	M12x1 / 10 mm (0.4 in)
Cable connector	4-pin M8 (IEC 60947-5-2)
Materials	
Body	Stainless steel (AISI 316)
Grid filter	Chrome coated ABS plastic
Cable	Polyurethane or FEP
Weight	
Probe	17 g (0.6 oz)
Probe with 0.3 m (1 ft) cable	28 g (1 oz)

Operating Environment

Operating temperature	-40 ... +80 °C (-40 ... +176 °F)
EMC compliance	EN 61326-1, industrial environment

Inputs and Outputs

Power consumption	1 mA average, max. peak 5 mA
Operating Voltage¹⁾	
With 1 V / 2.5 V output	5 ... 28 VDC
With 5 V output	8 ... 28 VDC
With loop power converter	8 ... 28 VDC
With digital output	5 ... 28 VDC
Start-Up Time	
HMP110 probes with analog output	4 s at operating voltage 13.5 ... 16.5 VDC 2 s at other valid operating voltages
HMP110 probes with digital output	1 s
Outputs	
2 channels	0 ... 1 VDC / 0 ... 2.5 VDC / 0 ... 5 VDC / 1 ... 5 VDC
1-channel loop-power converter (separate module, compatible with humidity accuracy only)	4 ... 20 mA
Digital output (HMP110 probes with digital output)	RS-485 2-wire half duplex, supports Modbus RTU
External Loads	
0 ... 1 V	R _L min 10 kΩ
0 ... 2.5 V / 0 ... 5 V	R _L min 50 kΩ

¹⁾ Use lowest available operating voltage to minimize heating.

Spare Parts and Accessories

4 ... 20 mA loop power converter	UI-CONVERTER-1CB
Mounting bracket for converter	225979
Plastic M12 installation nuts, pair	18350SP
USB cable for PC connection	219690
Probe mounting clamp set, 10 pcs	226067
Probe mounting flange	226061

Sensor Protection

Plastic grid	DRW010522SP
Membrane filter	DRW010525SP
Stainless steel sintered filter	HM46670SP
PTFE sintered filter	DRW244938SP

Connection Cables

Standard 0.3 m (1 ft)	HMP50Z032SP
Standard 3 m (9.8 ft)	HMP50Z300SP
+80 °C 1.5 m (+176 °F 5 ft)	225777SP
+80 °C 3 m (+176 °F 10 ft)	225229SP
+180 °C 3 m (+356 °F 10 ft) FEP	226902SP
Connection cable for HM70	219980SP
Flat extension cable 1 m (3 ft) ¹⁾	CBL210649SP

¹⁾ Connecting HMP110 to MI70 requires using both flat cable CBL210649SP and connection cable 219980SP.

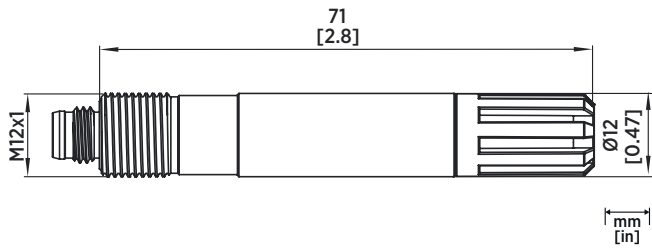

HMP110 Probe

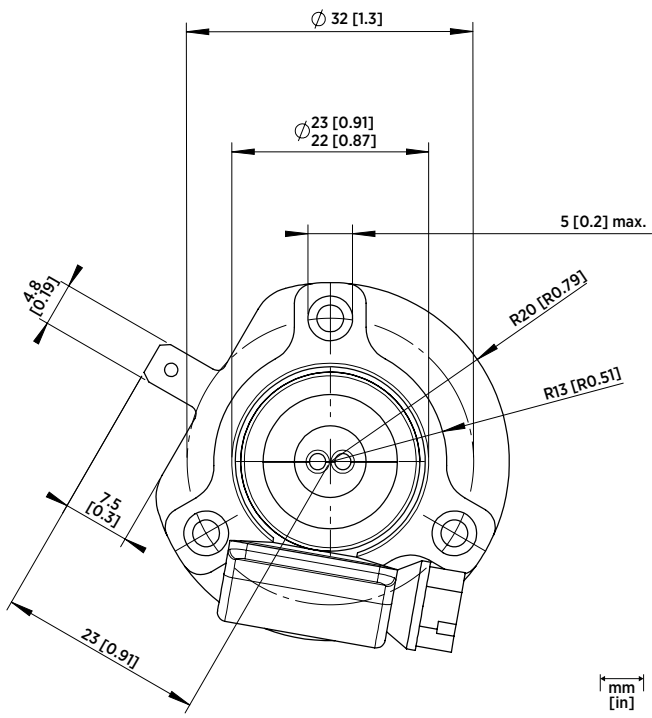

Probe Mounting Flange, Front View

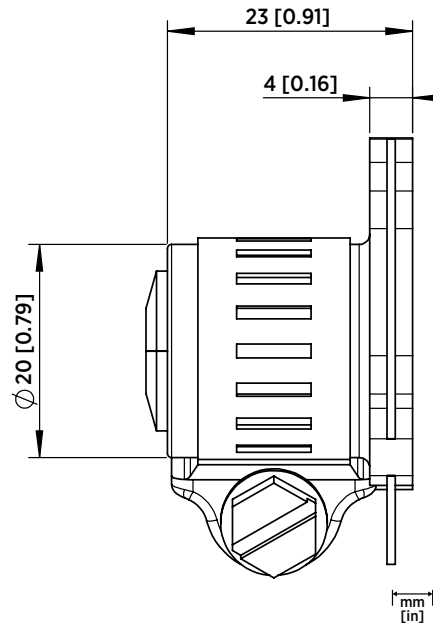

Probe Mounting Flange, Side View



Features

- Fast thermal response time
- Low power consumption
- Start-up time < 2 s
- Measurement range: 0 ... 100 %RH; -40 ... +60 °C
- Detachable cable with standard 4-pin M8 connector
- Plastic enclosure with IP54 classification
- Proven Vaisala HUMICAP® 180R sensor for excellent stability
- Optional RS-485 digital output
- Optional dew point calculation
- Comes with calibration certificate: ±1.5 %RH measurement accuracy (0 ... 90 %RH)

Vaisala HUMICAP® Humidity and Temperature Probe HMP113 is a highly accurate and cost-effective humidity probe with plastic enclosure. It is designed for indoor environments, integration into other manufacturers' equipment, or use with Vaisala HUMICAP® Hand-Held Humidity and Temperature Meter HM40.

Easy Installation

The compact probe fits into tight spaces. The cable has a threaded M8 connector for easy installation. Different cable lengths and a selection of accessories are available.

Low Power Consumption

HMP113 is suitable for battery powered applications due to its very low power consumption. It also has an extremely fast start-up time.

Several Outputs

There are two voltage outputs for relative humidity and temperature or dew point measurement. An optional RS-485 output with Modbus support is also available.

High Performance

HMP113 has a PC/ABS plastic enclosure and is suitable for noncondensing environments with fast temperature changes and a need for high accuracy

measurements with traceability. HMP113 also has a high chemical tolerance thanks to the proven Vaisala HUMICAP® 180R sensor.

Variety of Calibration Options

A quick field calibration can easily be carried out using a hand-held meter, for example Vaisala Hand-Held Meter HM40. Alternatively, the probe can be calibrated using a PC with USB cable or sent to a Vaisala Service Center.

Technical Data

Measurement Performance

Relative Humidity

Measurement range	0 ... 100 %RH
Accuracy (incl. Non-Linearity, Hysteresis and Repeatability):	
Temperature range	0 ... +40 °C
0 ... 90 %RH	±1.5 %RH
90 ... 100 %RH	±2.5 %RH
Temperature range	-40 ... 0 °C, +40 ... +60 °C
0 ... 90 %RH	±3.0 %RH
90 ... 100 %RH	±4.0 %RH
Factory Calibration Uncertainty (+20 °C):	
0 ... 90 %RH	±1.1 %RH
90 ... 100 %RH	±1.8 %RH
Humidity sensor	Vaisala HUMICAP® 180R
Stability	±2 %RH over 2 years

Temperature

Measurement range	-40 ... +60 °C
Accuracy over Temperature Range:	
0 ... +40 °C	±0.2 °C
-40 ... 0 °C, +40 ... +60 °C	±0.4 °C
Temperature sensor	Pt1000 RTD Class F0.1 IEC 60751

Dew Point

Measurement range	-40 ... +60 °C
Accuracy (incl. Non-Linearity, Hysteresis and Repeatability):	
Temperature range	0 ... +40 °C
When dew point depression < 15 °C	±1 °C
When dew point depression 15 ... 25 °C	±2 °C
Temperature range	-40 ... 0 °C, +40 ... +60 °C
When dew point depression < 15 °C ¹⁾	±2 °C

Analog Outputs

Accuracy at 20 °C	±0.2 % of FS
Temperature dependence	±0.01 % of FS/°C

¹⁾ Dew point depression = ambient temperature - dew point

Operating Environment

Operating temperature	-40 ... +60 °C
EMC compliance	EN 61326-1, basic immunity test requirements

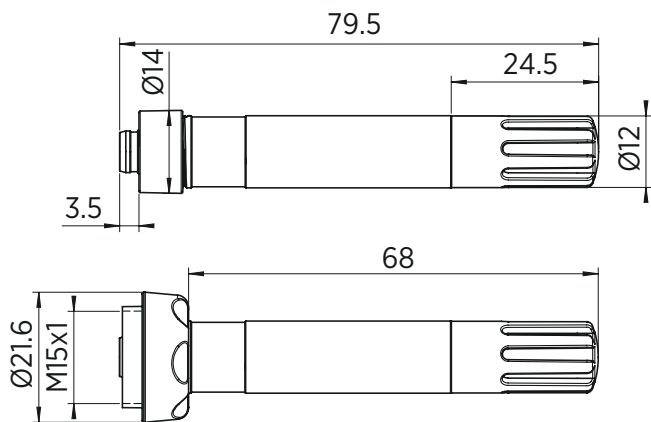

Dimensions in mm (inches)

Mechanical Specifications

IP rating	IP54
Cable connector	4-pin M8 (IEC 60947-5-2)
Materials	
Body	PC/ABS blend
Grid filter	PC (glass reinforced)
Cable	Polyurethane or FEP
Weight	
Probe	9 g
Probe with 0.3 m cable	20 g

Inputs and Outputs

Power consumption	1 mA average, max. peak 5 mA
Operating Voltage¹	
With 1 V / 2.5 V output	5 ... 28 VDC
With 5 V output	8 ... 28 VDC
With loop power converter	8 ... 28 VDC
With digital output	5 ... 20 VDC
Start-Up Time	
Probes with analog output	4 s at operating voltage 13.5 ... 16.5 VDC 2 s at other valid operating voltages
Probes with digital output	1 s

Outputs	
2 channels	0 ... 1 VDC / 0 ... 2.5 VDC / 0 ... 5 VDC / 1 ... 5 VDC
1-channel loop-power converter (separate module, compatible with humidity accuracy only)	4 ... 20 mA
Digital output (optional)	RS-485 2-wire half duplex

External Loads	
0 ... 1 V	R _L min 10 kΩ
0 ... 2.5 V / 0 ... 5 V	R _L min 50 kΩ

¹⁾ (Use Lowest Available Operating Voltage to Minimize Heating)

Spare Parts and Accessories

4 ... 20 mA loop power converter	UI-CONVERTER-ICB
Mounting bracket for converter	225979
USB cable for PC connection	219690
Probe mounting clamp set, 10 pcs	226067
Probe mounting flange	226061

Sensor Protection	
Plastic grid for use with HM40	DRW236214SP
Membrane filter	230727SP
Stainless steel sintered filter	HM47280SP
Porous PTFE filter	219452SP

Connection Cables	
Standard 0.3 m	HMP50Z032SP
Standard 3 m	HMP50Z300SP
80 °C 1.5 m	225777SP
80 °C 3 m	225229SP
180 °C 3 m FEP	226902SP



HM70 Handheld Humidity and Temperature Meter

For Spot-checking Applications



Features

- Designed for spot-checking and field calibration
- Multilingual user interface
- Shows measurement trends graphically
- Proven Vaisala HUMICAP® sensor technology
- 3 probe alternatives, temperature measurement ranges between -70 and +180 °C (-94 and +356 °F)
- 2 probes: also dew point and CO₂ probes can be connected simultaneously
- Displays various humidity parameters
- Sensor preheat and chemical purge options for demanding conditions
- 6-point traceable calibration (certificate included)

Vaisala HUMICAP® Handheld Humidity and Temperature Meter HM70 is designed for demanding humidity measurements in spot-checking applications. It is also ideal for field checking and calibration of Vaisala's fixed humidity instruments.

Vaisala HUMICAP® Technology

HM70 incorporates the world-class HUMICAP® sensor, one of the most reliable and stable sensors on the market. The HUMICAP® sensor copes well with chemical interference and provides accuracy that lasts in demanding conditions.

Chemical Purge

The chemical purge option maintains measurement accuracy in environments with high concentrations of chemicals. The sensor preheat option reduces measurement delays as it keeps the sensor dry when the probe is inserted into hot and humid processes.

Three Probes to Choose From

HMP75 is a general purpose probe, whereas HMP76 is a long, stainless steel probe especially suitable for spot-checking in ducts. HMP77 is a small probe at the end of a 5-meter cable. The probe is ideal for difficult-to-reach areas and for on-site calibration of Vaisala's process transmitters. In addition, HM70 supports the use of Vaisala's dew point, carbon dioxide, and moisture in oil probes, allowing measurements in several multiparameter applications.

MI70 Link

The optional MI70 Link Windows® software and the USB connection cable form a practical tool for transferring logged data and real time measurement data from HM70 to a computer.

Technical Data

Measurement Performance, HMP75, HMP76, and HMP77 Probes

Relative Humidity

Measurement range	0 ... 100 %RH
Accuracy including non-linearity, hysteresis and repeatability. Defined as ± 2 standard deviation limits:	
At +15 ... +25 °C (+59 ... +77 °F)	± 1.7 %RH (0 ... 90 %RH) ± 1.7 %RH (90 ... 100 %RH)
At -20 ... +40 °C (-4 ... +104 °F)	$\pm(1.0 + 0.008 \times \text{reading})$ %RH
At -40 ... +180 °C (-40 ... +356 °F)	$\pm(1.5 + 0.015 \times \text{reading})$ %RH
Factory calibration uncertainty (+20 °C / +68 °F)	± 0.6 %RH (0 ... 40 %RH) ± 1.0 %RH (40 ... 97 %RH)
Response time (90%) at +20 °C (+68 °F) in still air:	
HMP75 (with standard plastic grid)	17 s
HMP76 (with standard sintered bronze filter)	60 s
HMP77 (with standard plastic grid and stainless steel netting)	50 s
Typical long-term stability	Better than 1 %RH / year

Temperature

HMP75 measurement range	-20 ... +60 °C (-4 ... +140 °F)
HMP76 measurement range	-50 ... +120 °C (-58 ... +248 °F)
HMP76 short time measurement range	-50 ... +180 °C (-58 ... +356 °F)
HMP77 measurement range	-70 ... +180 °C (-94 ... +356 °F)
Accuracy at +20 °C (+68 °F)	± 0.2 °C (± 0.36 °F)

Accuracy over temperature range:

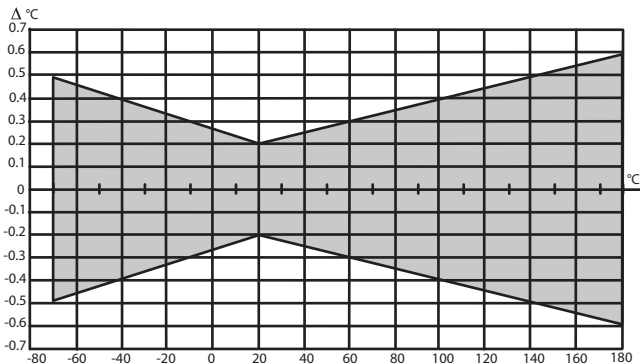

Other Variables Available

dew point, frost point, absolute humidity, mixing ratio, wet bulb temperature, water content, vapor pressure, saturation vapor pressure, enthalpy, water activity

General, HMP75, HMP76, and HMP77 Probes

Humidity sensor	HUMICAP® 180R HUMICAP® 180RC (chemical purge, sensor preheat)
Temperature sensor	Pt100 RTD Class FO.1 IEC 60751
Operating temperature range for electronics	-40 ... +60 °C (-40 ... +140 °F)
Standard Sensor Protection	
HMP75	Plastic grid
HMP76	Sintered bronze filter
HMP77	Grid with SS netting

Mechanical Specifications, HMP75, HMP76, and HMP77 Probes

Housing classification	IP65 (NEMA 4)
Housing material	ABS/PC blend
Probe material	Stainless steel (AISI316L)
Probe cable length (between indicator and probe handle)	1.9 m (6.2 ft)
Probe cable length of HMP77 (from handle to the root of probe)	5.0 m (16 ft)
Probe diameter	12 mm (0.47 in)
Weight	
HMP75	250 g (8.8 oz)
HMP76	350 g (12 oz)
HMP77	500 g (18 oz)

MI70 Measurement Indicator

Operating Environment

Operating temperature	-10 ... +40 °C (+14 ... +104 °F)
Operating humidity	0 ... 100 %RH, non-condensing
Storage temperature	-40 ... +70 °C (-40 ... +158 °F)

Inputs and Outputs

Max. no of probes	2
Power supply	Rechargeable NiMH battery pack with AC adapter or 4xAA size alkalines, type IEC LR6
PC interface	MI70 Link software with USB or serial port cable

Analog Output	
Scale	0...1 VDC
Output resolution	0.6 mV
Accuracy	0.2 % full scale
Temperature dependence	0.002 %/°C (0.01 %/°F) full scale
Minimum load resistor	10 kΩ to ground

Mechanical Specifications

Housing classification	IP54
Housing materials	ABS/PC blend
Weight	400 g (14 oz)

Compatibility

EMC compliance	EN61326-1, Portable Equipment
----------------	-------------------------------

Other

Menu languages	English, Chinese, Spanish, Russian, French, Japanese, German, Swedish, Finnish
Display	<ul style="list-style-type: none"> LCD with backlight Graphic trend display of any parameter Character height up to 16 mm (0.63 in)
Alarm	Audible alarm function
Data logging capacity	2700 real time data points
Logging interval	1 s to 12 h
Logging duration	1 min ... memory full
Resolution	0.01 %RH, 0.01 °C/°F, 0.01 hPa, 0.01 a _w , 10 ppm / 0.01 %CO ₂

Battery Operation Time

Typical charging time 4 hours

Operation Times

Continuous use	48 h typical at +20 °C (68 °F)
Data logging use	Up to a month

Spare Parts and Accessories

Carrying Cases

Weatherproof carrying case for MI70 and HMP75/77 probe	MI70CASE3
--	-----------

Weatherproof carrying case for MI70 and HMP76 probe	MI70CASE4
---	-----------

Soft carrying case for MI70 and HMP75/77 probe	MI70SOFTCASE
--	--------------

Transmitter Connection Cables

HMT330 & HMT120/130	211339
---------------------	--------

HMT310	DRW216050SP
--------	-------------

HMW90 Series, HMDW110 Series, HMP110 Series & GMW90 Series	219980SP
--	----------

1-m (3.3-ft) flat extension cable for 219980SP	CBL210649SP
--	-------------

HMD60/70 Series	HMA6070
-----------------	---------

Software

MI70 Link software with USB cable	219687
-----------------------------------	--------

MI70 Link software with serial port cable	MI70LINK
---	----------

Cables

Analog output cable	27168ZZ
---------------------	---------

10-m (32.81-ft) extension cable for probe	213107SP
---	----------

Sensor Protection HMP75

Plastic PC grid (HMP75 standard)	6221
----------------------------------	------

Membrane filter	10159HM
-----------------	---------

Sintered bronze filter	DRW212987SP
------------------------	-------------

Sensor Protection HMP76/77

Plastic PPS grid	DRW010276SP
------------------	-------------

Sintered stainless steel filter	HM47280SP
---------------------------------	-----------

Sintered bronze filter (HMP76 standard)	DRW212987SP
---	-------------

PPS grid with SS netting (HMP77 standard)	DRW010281SP
---	-------------

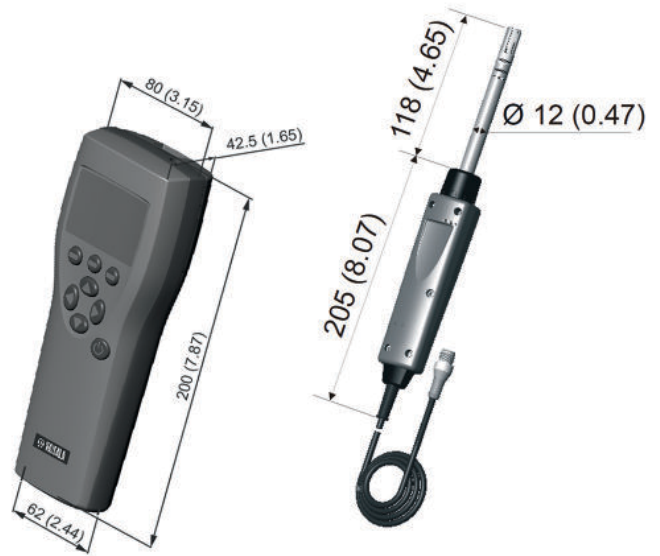

MI70 indicator and HMP75 probe dimensions in mm (inches)

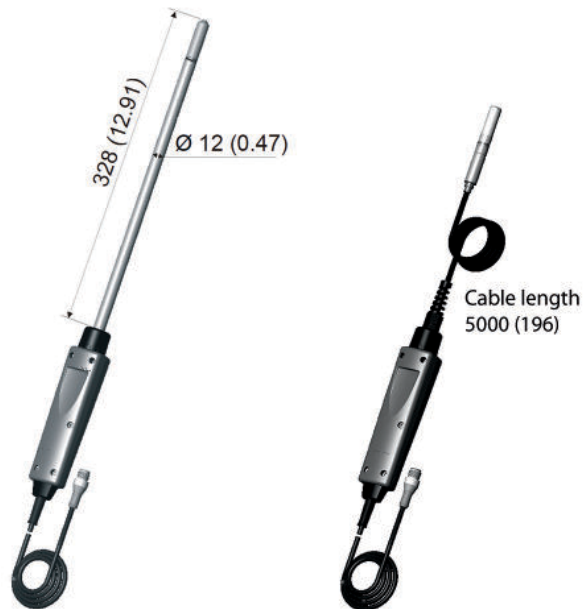

HMP76 and HMP77 probe with cable, dimensions in mm (inches)

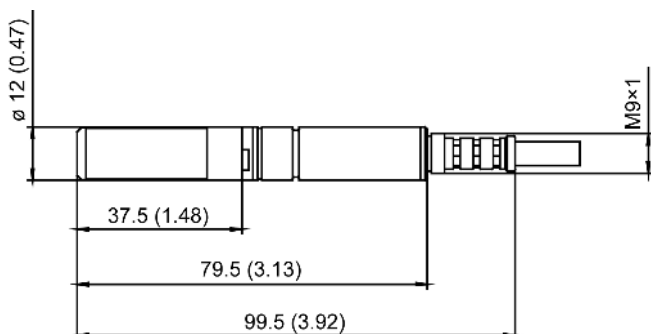

HMP77 probe dimensions in mm (inches)

VAISALA

www.vaisala.com



Features

- Humidity measurement range 0 ... 100 %RH
- Temperature measurement ranges -40 ... +100 °C (-40 ... +212 °F), depending on probe model. The HM46 model can measure up to +180 °C (+356 °F) for a short period of time.
- Incorporates proven Vaisala HUMICAP® sensor technology
- Calibration reminder function
- Probes can be user calibrated using an on-site reference
- Graphical display indicates when measurement has stabilized
- Hold-button to freeze the screen and save the reading
- Multilingual user interface available in 10 languages (EN, DE, FR, JA, ZH, PT, ES, RU, FI, SV)

The easy-to-use HM40 is a compact and portable humidity meter that provides reliable measurements in a wide range of applications. It is the ideal spot-checking tool for everything from structural moisture measurement and air conditioning systems to humidity measurement in industrial production processes and life science applications. There are four different models available: HM41, HM42, HM45, and HM46.

Benefits

- Compact, portable, and easy to use
- Versatile meter with wide measurement range and multiple calculated parameters
- Ideal for spot-checking in a wide variety of applications

Simple and Easy to Use

HM40 has a large, user-friendly graphical display and easy-to-use push buttons. The user interface is simple and intuitive, and available in 10 languages. Also, many settings can be modified to meet users' individual needs. In addition to relative humidity and temperature, HM40 provides five calculated humidity

parameters, all of which are available in metric and non-metric units. HM40 is powered by 2 AA batteries. An external USB-charger and rechargeable AA sized NiMH batteries are available as an option. Each model also comes with a handy belt clip and case.

Easy Recalibration

Calibrating HM40 is easy. The meter or the probe can be sent to a Vaisala Service Center for recalibration. Alternatively, calibration can be completed on site by users with a humidity reference such as another hand-held meter or Vaisala Humidity Calibrator HMK15. The indicator includes a calibration reminder function that can be activated by the user.

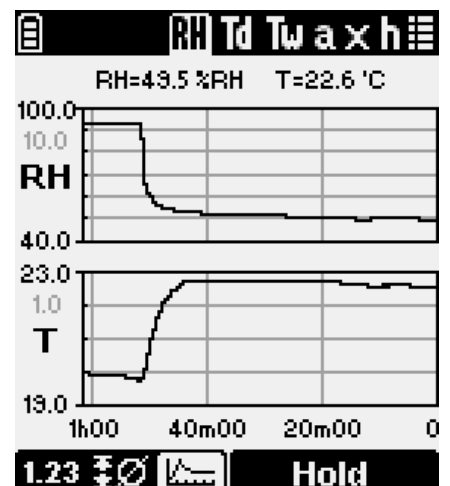

The Graph Clearly Indicates When Readings Have Stabilized.

HM40 Hand-Held Humidity and Temperature Meter Series



HM41 Technical Data

Humidity Measurement Accuracy (Including Non-linearity, Hysteresis, and Repeatability):

At 0 ... +40 °C	±1.5 %RH (0 ... 90 %RH) ±2.5 %RH (90 ... 100 %RH)
At -10 ... 0 °C and +40 ... +60 °C	±3.0 %RH (0 ... 90 %RH) ±4.0 %RH (90 ... 100 %RH)
Humidity sensor	HUMICAP® 180R
Temperature measurement range	-10 ... +60 °C (+14 ... +140 °F)
Temperature sensor	Pt1000 RTD Class F0.1 IEC 60751
Measurement probe	Interchangeable HMP113 probe
Probe material	PC/ABS plastic blend (white)
IP rating	IP54
Weight (with alkaline batteries)	230 g (8.1 oz)
Filter material	PC (glass-reinforced)

HM42 Technical Data

Humidity Measurement Accuracy (Including Non-linearity, Hysteresis, and Repeatability):

At 0 ... +40 °C	±1.5 %RH (0 ... 90 %RH) ±2.5 %RH (90 ... 100 %RH)
At -40 ... 0 °C and +40 ... +80 °C	±3.0 %RH (0 ... 90 %RH) ±4.0 %RH (90 ... 100 %RH)
At +80 ... +100 °C	±4.0 %RH ¹⁾
Humidity sensor	HUMICAP® 100R-Mini
Temperature measurement range	-40 ... +100 °C (-40 ... +212 °F)
Temperature sensor	Pt1000 RTD Class F0.3 IEC60751
Measurement probe	HM42PROBE
Probe head material	Stainless steel
IP rating	IP40 (probe), IP54 (indicator)
Weight (with alkaline batteries)	370 g (13.1 oz)
Filter material	Stainless steel and PTFE membrane
Probe cable length	1500 mm (59 in)

¹⁾ Not recommended for $T_d > 85 °C$

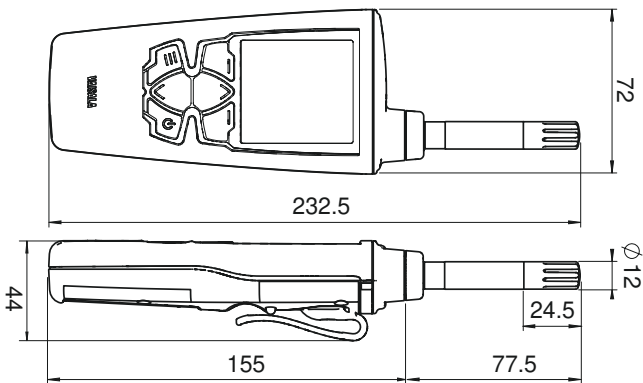

Dimensions in mm

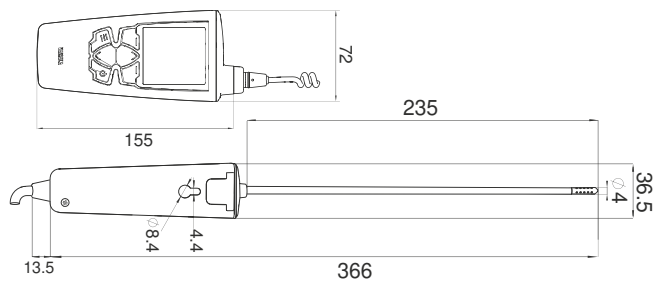

Dimensions in mm



HM45 Technical Data

Humidity Measurement Accuracy (Including Non-linearity, Hysteresis, and Repeatability):

At 0 ... +40 °C	±1.5 %RH (0 ... 90 %RH) ±2.5 %RH (90 ... 100 %RH)
At -40 ... 0 °C and +40 ... +60 °C	±3.0 %RH (0 ... 90 %RH) ±4.0 %RH (90 ... 100 %RH)
Humidity sensor	HUMICAP® 180R
Temperature measurement range	-40 ... +60 °C (-40 ... +140 °F)
Temperature sensor	Pt1000 RTD Class F0.1 IEC 60751
Measurement probe	Interchangeable HMP113 with HM40HANDLE
Probe material	PC/ABS plastic blend (white)
IP rating	IP54
Weight (with alkaline batteries)	330 g (11.6 oz)
Filter material	PC (glass-reinforced)
Probe cable length	1200 mm (47 in)

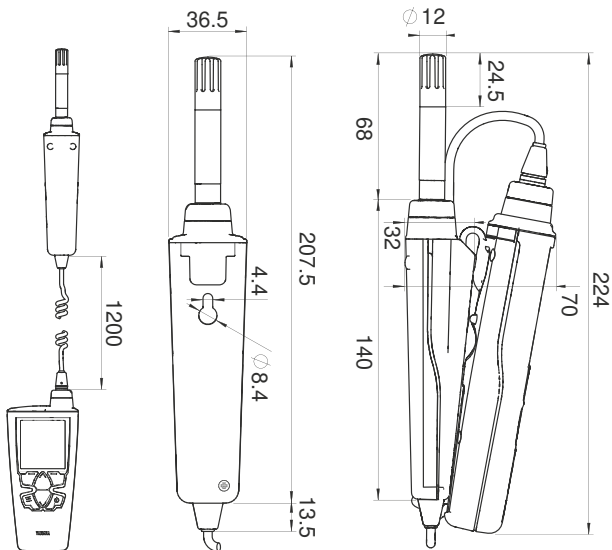

Dimensions in mm



HM46 Technical Data

Humidity Measurement Accuracy (Including Non-linearity, Hysteresis, and Repeatability):

At 0 ... +40 °C	±1.5 %RH (0 ... 90 %RH) ±2.5 %RH (90 ... 100 %RH)
At -40 ... 0 °C and +40 ... +80 °C	±3.0 %RH (0 ... 90 %RH) ±4.0 %RH (90 ... 100 %RH)
At +80 ... +100 °C	±4.0 %RH ¹⁾
Humidity sensor	HUMICAP® 180R
Temperature measurement range	-40 ... +100 °C (-40 ... +212 °F), short-term up to +180 °C (+356 °F)
Temperature sensor	Pt1000 RTD Class F0.1 IEC 60751
Measurement probe	HM46PROBE
Probe head material	Stainless steel, brass filter
IP rating	IP40 (probe), IP54 (indicator)
Weight (with alkaline batteries)	490 g (17.3 oz)
Filter material	Sintered brass
Probe cable length	1500 mm (59 in)

¹⁾ Not recommended for $T_a > 85$ °C

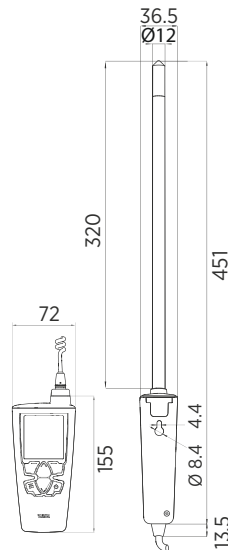

Dimensions in mm

HM40 Series Technical Data

Measurement Performance

Calculated parameters Dew point, wet bulb temperature, absolute humidity, mixing ratio, enthalpy

Relative Humidity

Measurement range	0 ... 100 %RH
Accuracy (including non-linearity, hysteresis, and repeatability) for different models at 0 ... +40 °C (+32 ... +104 °F)	±1.5 %RH (0 ... 90 %RH) ±2.5 %RH (90 ... 100 %RH)
Factory calibration uncertainty at +20 °C (+68 °F):	
HM42 and HM46	±1.5 %RH
HM41 and HM45	±1.1 %RH (0 ... 90 %RH) ±1.8 %RH (90 ... 100 %RH)
Stability	±2 %RH over 2 years

Humidity Measurement Response Time:

(90 %) with plastic grid filter (HM41 and HM45)	17 s
(90 %) with membrane filter and steel grid (HM42)	26 s
(90 %) with brass sintered filter (HM46)	40 s

Temperature

Accuracy over temperature range:

At 0 ... +40 °C (+32 ... +104 °F)	±0.2 °C (0.36 °F)
At -40 ... 0 °C and +40 ... +100 °C (-40 ... +32 °F and +104 ... +212 °F)	±0.4 °C (0.72 °F)

Operating Environment

Operating temperature

Indicator	-10 ... +60 °C (+14 ... +140 °F)
Probe handle	-40 ... +60 °C (-40 ... +140 °F)
Probe head	Range -40 ... +180 °C (-40 ... +356 °F) See probe specifications
Storage temperature	-30 ... +70 °C (-22 ... +158 °F)
EMC compliance	EN61326-1, Portable Equipment

Mechanical Specifications

Materials

Indicator body	PC/ABS blend, acrylic display lens
Probe holder	PC/ABS blend (gray)
Probe handle	PC/ABS blend (white), PC/ABS blend (gray, HM45) or PBT (gray, HM42/46)
HMP113 probe or probe measurement head	PC/ABS blend (white, HM41/45) or stainless steel (HM42/46)
IP rating, HM40	IP54

Indicator

Display	LCD (140 x 160 pixels)
Power-up time	< 3 s
Batteries	2 × AA, 1.5 V
Operation time (typical)	100 hours (without backlight)
Menu languages	English, Chinese (simplified), Finnish, French, German, Japanese, Portuguese, Russian, Spanish, Swedish

Spare Parts and Accessories

Indicator

Spare HM40 indicator	HM40INDI
Belt clip (3 pcs)	227710SP
Battery cover (3 pcs)	225688SP
NiMH rechargeable batteries (4 pcs)	229247SP
External battery recharger with USB connection and 4 batteries	229249SP
Case for short HM40 probes	235849SP
Case for long HM40 probes	DRW242351SP

Standard Probe (HM41)

HMP113 probe for HM40	HMP113 (configuration: V00B2C1A0)
Plastic locking bushing (3 pcs) for attaching HMP113 probe to HM40 indicator	DRW238590SP
Plastic grid filter for HMP113 probe	DRW236214SP
Plastic grid with membrane filter for HMP113 probe	230727SP

HM42 Probe (HM42)

Thin 4 mm diameter probe for HM40	HM42PROBE
Steel grid filter for HM42PROBE	19867HM
Membrane tube set (5 pcs) for HM42PROBE	19858HM
Rubber sleeve set (10 pcs) for HM42PROBE	19809HM
Calibration adapter for HM42PROBE	HM37067

Remote Probe (HM45)

HMP113 probe for HM40	HMP113 (configuration: V00B2C1A0)
Plastic locking bushing (3 pcs) for attaching HMP113 probe to HM40 indicator	DRW238590SP
HM40 handle and cable	HM40HANDLE
Plastic grid filter for HMP113 probe	DRW236214SP
Plastic grid with membrane filter for HMP113 probe	230727SP

HM46 Probe (HM46)

Stainless steel 12 mm diameter probe for HM40	HM46PROBE
Sintered filter for HM46PROBE	0195
Optional membrane filter for HM46PROBE (up to +80 °C)	10159HM
Plastic grid filter for HM46PROBE (up to +80 °C)	6221
Disposable sleeve, 50 pcs set	1558
Probe holder	HM36915

VAISALA

www.vaisala.com



Features

- Truly interchangeable measurement probes
- Accurate measurement data in numeric, statistic or graph views
- Conforms to ASTM standard F2170
- IP65 classified measurement probe and case

Vaisala HUMICAP® Structural Humidity Measurement Kit SHM40 offers an easy and reliable solution for humidity measurements in concrete and other structures.

Measuring Humidity under the Surface

Concrete dries unevenly and is usually drier on the surface, consequently it is important to measure beneath the surface conditions. The borehole method provides information about the humidity profile under the surface. In this method, a humidity probe is left in the borehole until the humidity in the hole has reached an equilibrium state and the stabilized values can be read.

SHM40 is All You Need for Borehole Humidity Measurement

The Vaisala HUMICAP® Structural Humidity Measurement Kit SHM40 is an ideal solution for the borehole method. The starter kit is comprised of an

HMP40S probe, HM40 indicator and accessories for the borehole method in a weather-proof case, optimized for use in harsh and humid construction sites. Additional accessories for the SHM40 can be used to prepare a moisture measurement hole in fresh concrete. Pre-formed holes eliminate the need for drilling and the risk of damaging heating elements or tubing embedded in the concrete.

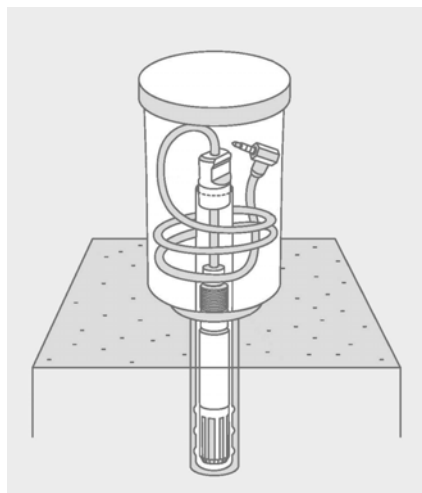

Borehole in concrete and a measurement probe HMP40S inserted in it.

Standard Contents of SHM40

- HM40 indicator with adapter
- 1 piece HMP40S RH&T probe with a cable
- 12 pcs plastic tubes (19266HM)
- 12 pcs rubber plugs (233976)
- 3 pcs protective covers with lid (19268HM)
- Traceable calibration certificate
- Weather-proof carrying case with a shoulder strap

SHM40 Structural Humidity Measurement Kit

Easy Measurement with Multiple HMP40S Probes and Quick Connectors

HMP40S measurement probes are interchangeable. The probes connect easily to the HM40 indicator with a snap-on connector enabling convenient use of multiple probes with one indicator. The measurement data can be displayed in numeric, statistic or graph views.



Snapping a connector to the indicator HM40 to read the measurement results.

Technical Data

HMP40S Probe Measurement Performance

Relative Humidity

Measurement range	0 ... 100 %RH
Accuracy (incl. non-linearity, hysteresis, and repeatability)	
temperature range: 0 °C ... +40 °C	0 ... 90 %RH: ± 1.5 %RH 90 ... 100 %RH: ± 2.5 %RH
temperature range: -40 °C...0 °C and +40 °C ... +80 °C	0 ... 90 %RH: ± 3.0 %RH 90 ... 100 %RH: ± 4.0 %RH
Factory calibration uncertainty at +20 °C (68 °F)	
	0 ... 90 %RH: ± 1.1 %RH 90 ... 100 %RH: ± 1.8 %RH
Humidity sensor	HUMICAP® 180R
Stability	± 2 %RH over 2 years

Temperature

Measurement range	-40 °C ... +80 °C
Accuracy over temperature range:	0 ... +40 °C: ± 0.2 °C -40 ... 0 °C, +40 ... +80 °C: ± 0.4 °C
Temperature sensor	Pt1000 RTD Class F0.1 IEC 60751

HMP40S Probe Mechanical Specifications

Probe weight with standard cable	31 g
Probe housing material	stainless steel
Probe filter and sensor protection	membrane filter with chrome coated ABS plastic
Cable material	Wire PVC / jacket PU
Cable connector	TRRS male 3.5 mm
Probe housing classification	IP65
Borehole diameter needed	16 mm
Measurement depth with standard accessories	min. 30 mm, max. 90 mm

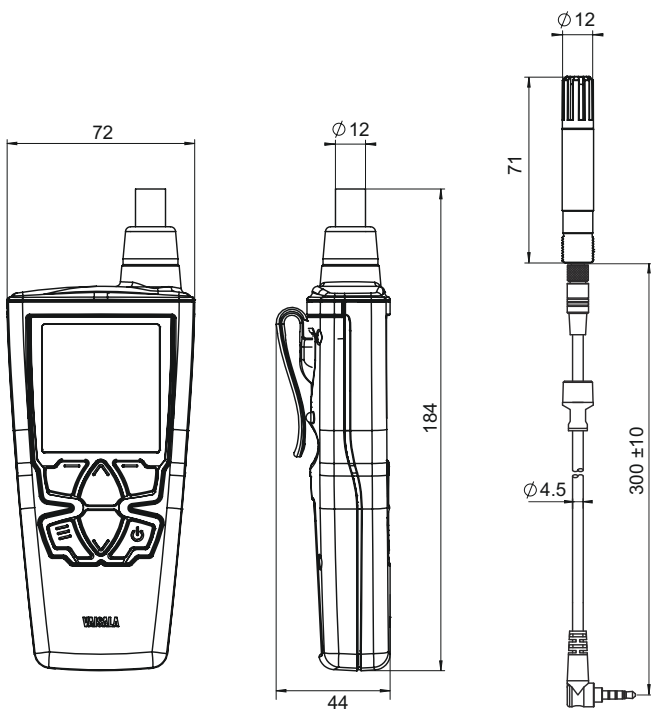

Dimensions in mm

Operating Environment

Operation temperature range for probe	-40 °C ... +80 °C
Operation temperature range for indicator	-10 ... +60 °C
Storage temperature range	-30 ... +70 °C

HM40 Indicator Mechanical Specifications

Weight	
Indicator with adapter	240 g
SHM40 case with standard content	3.7 kg
Indicator materials	PC/ABS blend, acrylic display lens
Indicator adapter materials	Nickel plated brass and plastic overmolding
Indicator housing classification	IP54
Mechanical drop endurance	1.0 m without the probe

HM40 Indicator - General

Power-up time	< 3 s
Alkaline batteries	2 x AA sized, 1.5V (LR6)
Operation time (Alkaline batteries)	typical 100 hours (without backlight)
Calculated variables	Td, Tw, a, x, h
Menu languages	English, German, French, Finnish, Spanish, Swedish, Chinese (simplified), Russian, Japanese
Display	LCD (140 x 160 pixels)
Electromagnetic compatibility (EMC)	European Union directive EN61326-1 for portable equipment

Spare Parts and Accessories

HM40 indicator with adapter and cable	HM40S
probe	
RH&T probe with cable	HMP40S
HM40 indicator with adapter	HM40SINDI
Quick connection adapter	HM40SADAPTER
Cable for RH&T probe	HMP40SCABLE
Long cable (2.7 m) for RH&T probe	HMP40SCABLE2
Plastic tube set (12 pcs)	19266HM
Long (200 mm) plastic tube set (12 pcs)	245789
Rubber plugs (12 pcs)	233976
Protective cover with lid (3 pcs)	19268HM
Weather-proof carrying case with SHM40 filling	233815
USB recharger for HM40 indicator batteries	229249SP
Plastic grid with membrane filter for HMP40S probe	DRW010525SP
Accessories for Wet Concrete	
Plastic flange set (12 pcs)	26529HM
Long rubber plug for wet concrete (12 pcs)	26530HM



Features

- Easy and reliable calibration of humidity probes and transmitters
- Based on saturated salt solutions
- Fast temperature equilibration
- No external power required
- Suitable for laboratory use and on-site checks
- Chambers and transit covers make HMK15 easy to transport
- Pre-measured certified salts available
- Vaisala Service Centers offer accredited calibrations for humidity, temperature and barometric pressure.

No measuring instrument stays accurate by itself. It is essential that the functioning of an instrument is periodically checked against a reference. Vaisala has developed Vaisala Humidity Calibrator HMK15 to make calibration and spot checking of humidity probes and transmitters easy and reliable.

Benefits

- Easy to use
- Reliable calibration
- Certified and pre-measured salts available on order of HMK15

Method Used by Leading Laboratories

The operating principle of HMK15 is based on the fact that a saturated salt solution generates a certain relative humidity in the air above it. The reading of the humidity probe or transmitter can then be adjusted accordingly. Many leading laboratories use this generally

accepted and reliable method to calibrate humidity instruments. Usually two or three different salt solutions are used. Salts are chosen according to the application.

Certified Salts

HMK15 can be ordered with certified and pre-measured salts. A sample calibration is made from each batch in Vaisala's Measurement Standards Laboratory (MSL).

FINAS Accredited Measurement Standards Laboratory

Vaisala's Measurement Standards Laboratory is a FINAS accredited calibration laboratory. FINAS is a member of the EA (the European Cooperation for Accreditation).



Technical Data

Accessories

Certified and ready dosed salts:	Order code:	Total uncertainty¹⁾:
LiCl salt 11 %RH	19729HM	(±1.3 %RH)
MgCl ₂ salt 33 %RH	19730HM	(±1.2 %RH)
NaCl salt 75 %RH	19731HM	(±1.5 %RH)
K ₂ SO ₄ salt 97 %RH	19732HM	(±2.0 %RH)
Ion exchanged water	19767HM	
Extra salt chambers	19766HM	
Carrying bag	HM27032	
Set of rubber plugs	19746HM	
Cover for DMT132 and HMP110 with filter	230914	
Adapter for HMP42 probe	HM37067	

1) Uncertainties given at +20 °C

Parts

The standard HMK15 consists of the following:

Two salt chambers, chamber covers and transit covers

Base plate

Thermometer

Measurement cup and mixing spoon

HMP155 Humidity and Temperature Probe



HMP155 with an additional temperature probe and optional Stevenson screen installation kit.

Features

- Vaisala HUMICAP®180R sensor: superior long-term stability
- Optional warmed humidity probe and chemical purge
- Plug-and-play
- USB connection for service use
- Use with DTR13 and DTR503 radiation shields and a Stevenson screen
- Weather-proof housing IP66
- Optional, fast temperature probe
- Different output possibilities: voltage, RS-485, resistive Pt100
- Applications: meteorology, aviation and road weather, instrumentation

Vaisala HUMICAP® Humidity and Temperature Probe HMP155 provides reliable humidity and temperature measurement. It is designed especially for demanding outdoor applications.

Long-term Stability

HMP155 uses the proven Vaisala HUMICAP®180R sensor that has excellent stability and withstands well harsh environments. The probe structure is solid and the sensor is protected by default with a sintered teflon filter, which gives maximum protection against water, dust, and dirt.

Warmed Probe and High-Humidity Environment

Measuring humidity reliably is challenging in environments where humidity is near saturation. Measurements may be corrupted by fog, mist, rain, and heavy dew. A wet probe may not give an accurate measurement in the ambient air.

This is an environment to which Vaisala has designed this patented, warmed probe for reliable measurements. As the sensor head is warmed continuously, the humidity level inside it stays below the ambient level. Thus, it also reduces the risk of condensation forming on the probe.

Fast Measurements

With its fast response time, the additional temperature probe for HMP155 is ideal for measuring in environments with changing temperatures. The membrane filter speeds up the relative humidity measurement.

Long Lifetime

Protecting the sensor from precipitation, and scattered and direct solar radiation increases its lifetime. Thus, Vaisala recommends installing HMP155 in one of the following radiation shields: DTR503, DTR13, or Stevenson screen. For the additional temperature probe, an installation kit is available to be used with Vaisala DTR502 Radiation Shield.

Calibration

The probe can be calibrated using a computer with a USB cable, with the push buttons, or with the MI70 indicator.

Technical Data

Humidity Measurement Performance

Sensor	HUMICAP®180R for typical applications HUMICAP®180C for applications with chemical purge and/or warmed probe
Observation range	0 ... 100 %RH
Response time at +20 °C (+68 °F) in still air with sintered teflon filter	63 %: 20 s 90 %: 60 s
Factory calibration uncertainty at +20 °C (+68 °F) ¹⁾	±0.6 %RH (0 ... 40 %RH) ±1.0 %RH (40 ... 97 %RH)
Accuracy (Including Non-linearity, Hysteresis, and Repeatability)	
At +15 ... +25 °C (+59 ... +77 °F)	±1 %RH (0 ... 90 %RH) ±1.7 %RH (90 ... 100 %RH)
At -20 ... +40 °C (-4 ... +104 °F)	±(1.0 + 0.008 × reading) %RH
At -40 ... -20 °C (-40 ... -4 °F)	±(1.2 + 0.012 × reading) %RH
At +40 ... +60 °C (+104 ... +140 °F)	±(1.2 + 0.012 × reading) %RH
At -60 ... -40 °C (-76 ... -40 °F)	±(1.4 + 0.032 × reading) %RH

¹⁾ Defined as ±2 standard deviation limits. Small variations possible (see also the calibration certificate).

Temperature Measurement Performance

Sensor	Pt100 RTD Class F0.1 IEC 60751
Observation range	-80 ... +60 °C (-112 ... +140 °F)
Response time for additional temperature probe in 3 m/s (7 mph) air flow	63 %: < 20 s 90 %: < 35 s
Other measured variables	Dew point / frost point temperature, wet bulb temperature, mixing ratio
Accuracy with Voltage Output	
At -80 ... +20 °C (-112 ... +68 °F)	±(0.226 - 0.0028 × temperature) °C
At +20 ... +60 °C (+68 ... +140 °F)	±(0.055 + 0.0057 × temperature) °C
Accuracy with Passive (Resistive) Output	
According to IEC 751 1/3 Class B	±(0.1 + 0.00167 × temperature) °C
Accuracy with RS-485 Output	
At -80 ... +20 °C (-112 ... +68 °F)	±(0.176 - 0.0028 × temperature) °C
At +20 ... +60 °C (+68 ... +140 °F)	±(0.07 + 0.0025 × temperature) °C

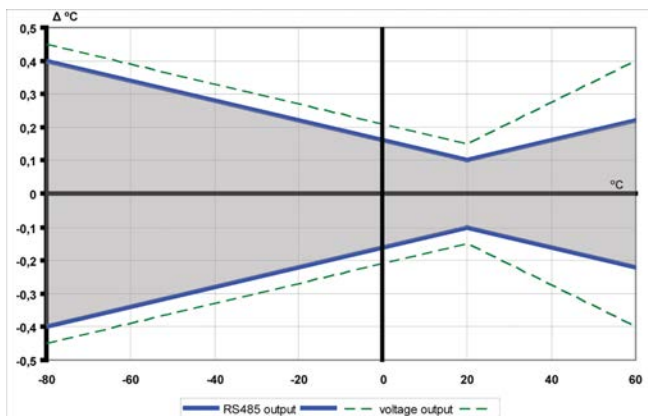

HMP155 Accuracy over Temperature Range: Voltage and RS-485

Operating Environment

Operating temperature for humidity measurement	-80 ... +60 °C (-112 ... +140 °F)
Storage temperature	-80 ... +60 °C (-112 ... +140 °F)
Operating humidity	0 ... 100 %RH
EMC (industrial environment)	EN/IEC 61326-1, EN 55022

Inputs and Outputs

Operating voltage	7 ... 28 VDC
Minimum Operating Voltage	
0 ... 5 V output	12 V
0 ... 10 V output, probe heating, chemical purge, or XHEAT	16 V
Outputs	
Voltage output	0 ... 1 V, 0 ... 5 V, 0 ... 10 V
Resistive Pt100 4-wire connection	
RS-485	
Average Power Consumption (+15 VDC, Load 100 kΩ)	
0 ... 1 V output	< 3 mA
0 ... 10 V output	+0.5 mA
RS-485	
During chemical purge	Maximum 110 mA
With warmed probe	Maximum 150 mA
Settling Time at Power-up	
Voltage output	2 s
RS-485	3 s

Mechanical Specifications

IP rating	IP66
Dimensions (H × W)	279 × 40 mm (10.9 × 1.6 in)
Weight	86 g (3.0 oz)
Additional T probe cable length	2 m
Connection	8-pin male M12 connector
Connection cables	3.5, 10, and 30 m
Wire size	AWG 26 (0.129 mm ²)
Service cables	USB connection cable MI70 connection cable
Materials	
Filter	Sintered teflon or membrane
Housing	Polycarbonate (PC)
Additional temperature probe	Stainless steel AISI 316L
Cable	PUR

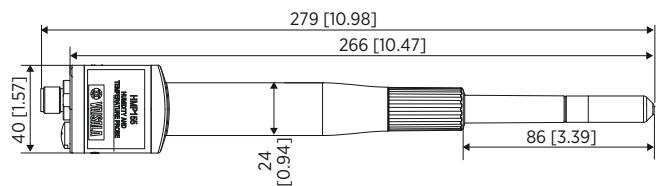

Dimensions in mm (inches)

DTR500 Solar Radiation and Precipitation Shields



Vaisala Radiation Shield Series DTR500 are solar radiation and precipitation shields supporting humidity probe installations in outdoor applications.

Sensor Protection

The maintenance-free DTR500 series shields protect the humidity and temperature sensors from solar radiation and precipitation. They provide excellent ventilation while blocking both direct and reflected solar radiation.

The special plastic used in the plates has excellent thermal characteristics: the white outer surface reflects radiation, and the black inside absorbs accumulated heat. The shields can be easily installed on a vertical pole, horizontal beam, or flat surface.

The DTR Shields can be used with the following Vaisala products:

- **DTR502(A)** with adapter 221072:
 - Vaisala HUMICAP® Humidity and Temperature Probe HMP155's additional temperature sensor
- **DTR502B:**
- Vaisala HUMICAP® Humidity and Temperature Transmitters HMT333, HMT337, HMT363, and HMT367
- Vaisala HUMICAP® Humidity and Temperature Probe HMP7
- Vaisala Combined Pressure, Humidity and Temperature Transmitters PTU303 and PTU307
- **DTR503(A):**
 - Vaisala HUMICAP® Humidity and Temperature Probe HMP155
- **DTR504(A):**
 - Vaisala HUMICAP® Humidity and Temperature Transmitters HMT120/130
 - Vaisala HUMICAP® Humidity and Temperature Probe HMP110
 - Vaisala INTERCAP® Humidity and Temperature Probe HMP60

Features

- Protects temperature and humidity probes from both scattered and direct solar radiation and rain
- Maintenance-free
- Naturally ventilated
- Installs easily on a vertical pole, horizontal beam, or flat surface
- Suitable for a wide selection of applications
- Choice of shields and mounting accessories

Technical Data

DTR502B for HMT333, HMT337, HMT363, HMT367, HMP7, PTU303, and PTU307

Dimensions (H × W)	200 × 105 mm (7.87 × 4.13 in)
Accessories	Product specific adapter

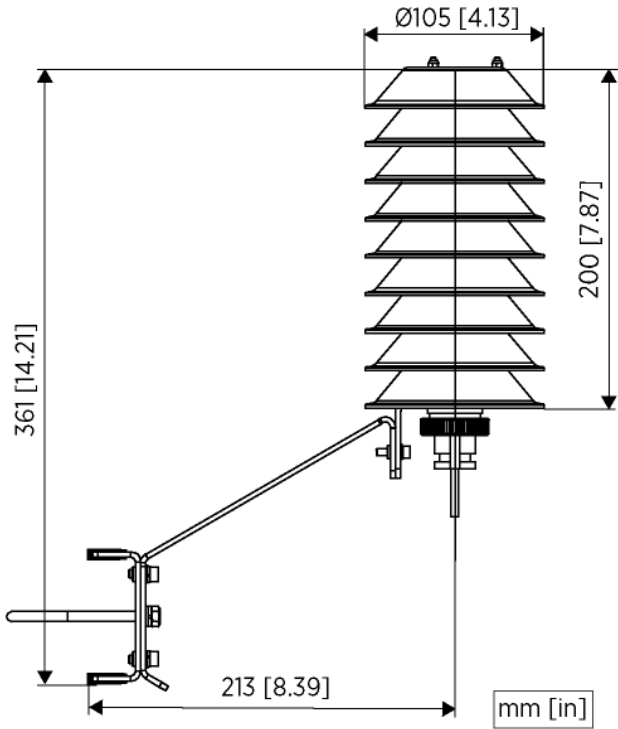

DTR503A for HMP155

Dimensions (H × W)	266 × 105 mm (10.47 × 4.13 in)
Accessories	Horizontal beam assembly Pole mast installation kit

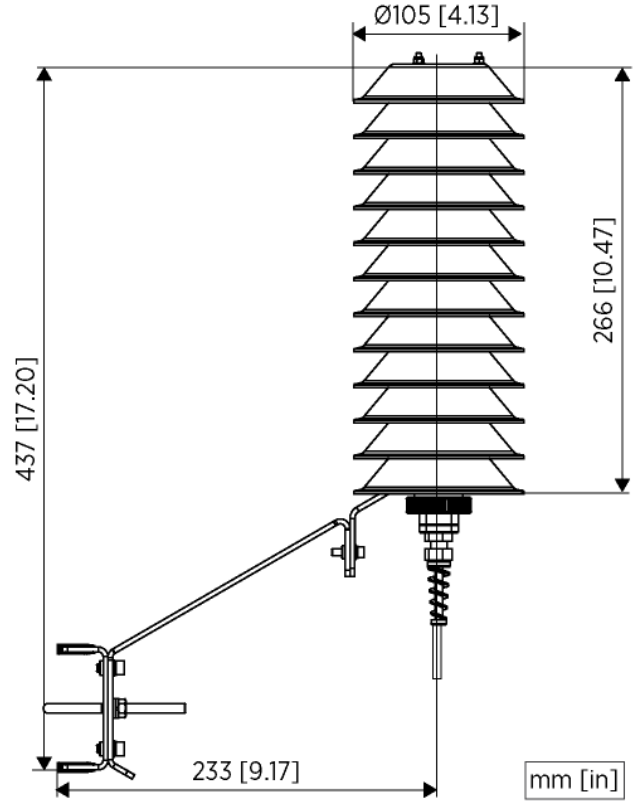

DTR504 for HMT120/130 remote probes, HMP110, and HMP60

Dimensions (H × W)	141 × 105 mm (5.55 × 4.13 in)
Accessories	Horizontal beam assembly Pole mast installation kit

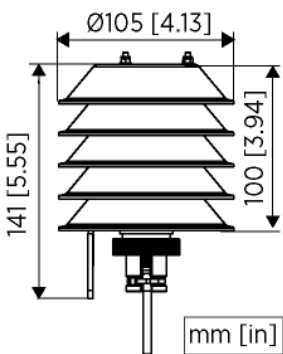

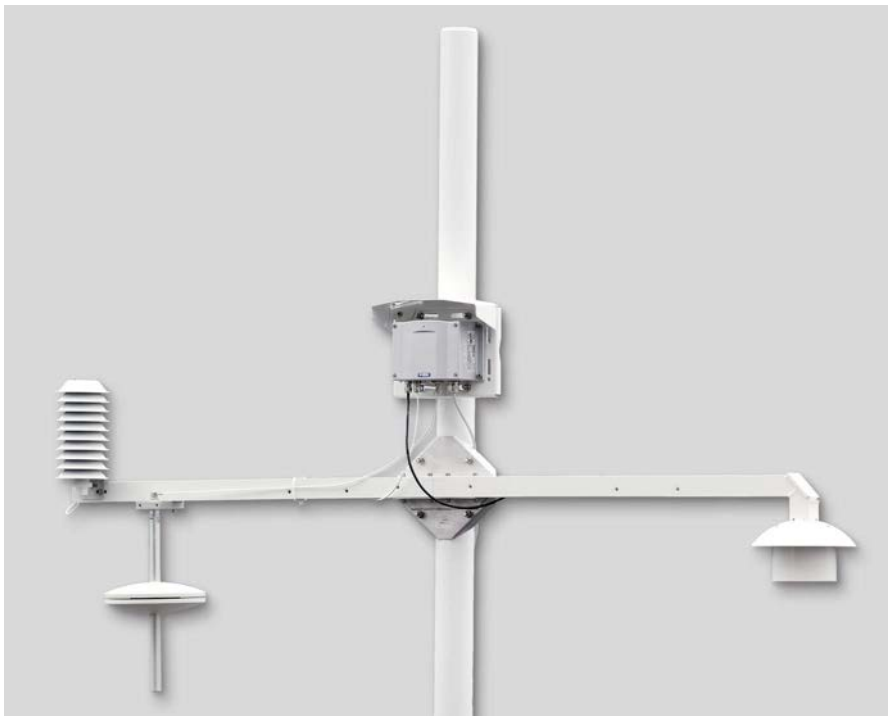

HMT337 and PTU307 feature warmed probe technology. Installed with the HMT330MIK kit either one forms the right choice for reliable humidity measurement in humid weather conditions.

Features

- For outdoor humidity and temperature measurements
- Can be ordered in a variety of configurations
- Used together with HMT337 transmitter or PTU307
- Vaisala SPH 10/20 Static Pressure Head eliminates effectively pressure variations in the barometer caused by wind

HMT337/PTU307 Features

- Warmed probe provides true humidity readings in condensing conditions
- Humidity measurement expressed as relative humidity and/or dew point temperature
- Easy field calibration with HM70 hand-held meter

Vaisala Meteorological Installation Kit HMT330MIK enables Vaisala HUMICAP® Humidity and Temperature Transmitter HMT337 to be installed outdoors to obtain reliable measurements for meteorological purposes.

True Humidity Readings in Condensing Conditions

In weather observations dew formation makes reliable humidity measurement difficult. When dew has formed on the humidity sensor, it is impossible to obtain a true reading until this dew evaporates.

Both PTU307 and HMT337 avoid this problem by warming the probe. When warmed, the relative humidity inside the probe stays below the ambient level. With an accurate temperature measurement, the ambient dew point can be calculated precisely. To obtain the ambient relative humidity, an additional probe measures the ambient temperature, and the transmitter calculates the relative humidity from the dew point and temperature values.

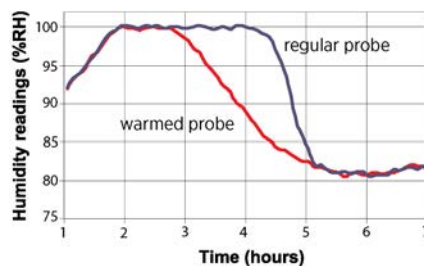

After a period of 100 % relative humidity, the warmed probe measures the true humidity, whereas the non-warmed probe takes time to recover from the condensation.

Open Shield Prevents Microclimates

The warmed probe of HMT337/PTU307 is mounted in a shield which is open at the bottom to ensure steady air circulation to the sensor even in calm weather.

In traditional radiation shields sleet or snow can accumulate on the shield and prevent the proper air circulation through the shield, and create a humid microclimate until the snow melts.

Essential for Critical Weather Measurements

Obtaining a true humidity reading is particularly important e.g. in traffic safety: at airports and at sea as well as on the roads. It is essential, for example, in fog and frost prediction.



For calibration, a portable HMP77 reference probe is easy to attach beside HMT337 or PTU307 probe.

Technical Data

Radiation shield options:

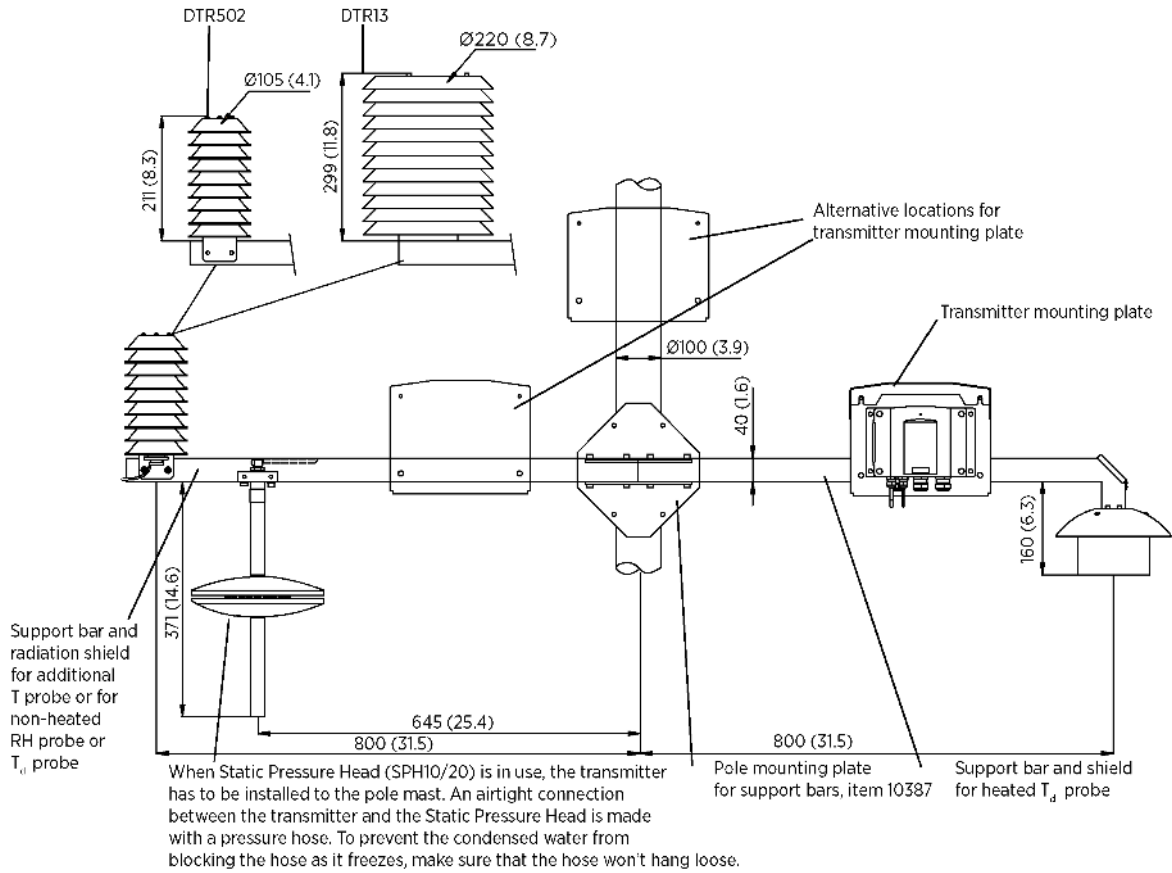

Dimensions in mm (inches)

Vaisala Meteorological Installation Kit		HMT330MIK	1	2	3	4	5	PRICE
1	Support bar & shield for warmed Td probe	No support bar & shield for warmed Td probe <i>Support bar & shield for warmed Td probe</i>	0					
			1					
2	Support bar and radiation shield for additional T probe or for non-warmed RH or Td probe	No support bar or radiation shield <i>Support bar with DTR502 shield for T probe</i> <i>Support bar with DTR13 shield for T probe</i> <i>Support bar with DTR502 shield for non-warmed RH or Td probe</i> <i>Support bar with DTR13 shield for non-warmed RH or Td probe</i>		A				
				B				
				C				
				D				
				E				
3	Support bar mounting plate	No mounting plate <i>Pole mounting plate for support bar/bars (item 10387)</i>	0					
			1					
4	Additional transmitter mounting plate (incl. rain shield)	No additional transmitter mounting plate <i>Transmitter mounting plate for support bar assembly</i> <i>Transmitter mounting plate for pole assembly</i>		A				
				B				
				C				
5	Static Pressure Head	No Static Pressure Head <i>Static Pressure Head SPH10 Only for the PTU300</i>					0	
							1	
							TOTAL	
							QTY	
							TOTAL VALUE	

Order form





Features

- Designed for high humidity applications
- Dew point measurement range: -40 ... +100 °C
- Patented, warmed probe
- Incorporates Vaisala HUMICAP® Sensor for excellent accuracy and long-term stability and resistance to dust and most chemicals
- Low maintenance need
- Outer cover provides protection from rain and direct sunlight

Vaisala HUMICAP® Turbine Mounting Kit HMT300TMK is developed to monitor the air intake of gas and liquid fueled power turbines. HMT300TMK is used together with HMT337 Temperature and Humidity Transmitter (not included in the HMT300TMK).

HMT300TMK is ideal for measuring in water vapor injection applications because the sensor has been optimized for high humidity environments by utilizing a patented, warmed probe. Water vapor is added to the intake of the turbine to increase the mass flow which in turn increases compression and electrical power output.

Low Maintenance

Power turbines also require exact water vapor injection in the chamber to reduce pollutant emissions. Vaisala's warmed probe technology is ideal because of its reliability in the field. In fact, the only suggested scheduled maintenance is annual calibration.

Patented, Warmed Probe Prevents Condensation

HMT300TMK, with HMT337 installed, provides fast and reliable dewpoint measurement especially under high humidity conditions where dew would

normally form on the humidity sensor and thereby cause errors in measurement. The patented warmed probe prevents condensation from forming on the sensor.

Protective Enclosure

HMT300TMK includes a white, painted stainless steel enclosure with an installation kit for the probe. HMT337 Humidity and Temperature Transmitter is installed in the stainless steel enclosure at the factory, when ordered together with HMT300TMK. The instrument can be equipped to be powered with either 24 VDC/VAC or with an internal 110/230 volt power supply unit.

The outer cover protects the transmitter from direct sunlight and rain. The installation kit protects the probe from outer water splashes, keeps the sensor dry, and prevents any parts that could vibrate loose from entering the turbine.

HMT300TMK can be ordered separately for installation with the customer's existing HMT337.

HUMICAP® Performance

HMT330 Series Transmitters are fitted with the latest generation of the HUMICAP®, the polymer sensor known for its accuracy, reliability and long-term stability. The sensor has a high tolerance for particulate abrasion and chemical contamination.

Vaisala HUMICAP® Humidity and Temperature Transmitter HMT337

HMT337 is intended for demanding industrial humidity measurement applications with a risk of condensation. The stainless steel probe is mechanically durable and preferred for most industrial applications.

Technical Data

Measurement Performance

Dew point measurement range -40 ... +100 °C (-40 ... +212 °F)

Accuracy: find the intersection of the dewpoint temperature curve and the dewpoint difference reading (process temperature - dewpoint temperature) on the x-axis and read the accuracy in dewpoint measurement at the y-axis

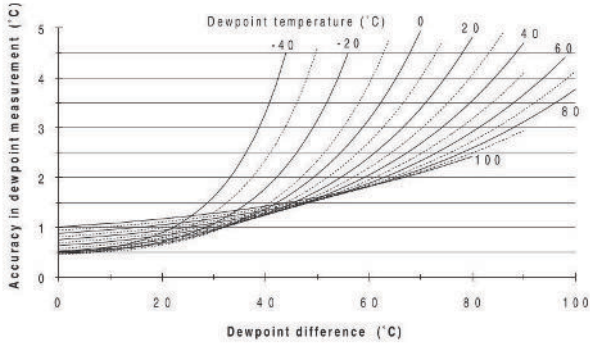

Response time (90 %) at +20 °C (68 °F) 20 s
in still air (PPS grid with steel netting)

Inputs and Outputs

Operating voltage 24 VDC/VAC (20 ... 28 V) or 115/230 VAC
(Must be specified at time of order)

Two standard outputs, third optional 0 ... 20 mA, 4 ... 20 mA, 0 ... 1 V,
0 ... 5 V, 0 ... 10 V

Typical accuracy of analog output at +20 °C (+68 °F) ±0.05 % full scale

Typical temperature dependence of analog output ±0.005 % / °C full scale

Serial output available RS-232C (optional RS-485)

Recommended external load for current outputs < 500 Ω

For 0 ... 1 V output > 2 kΩ (to ground)

For 0 ... 5 and 0 ... 10 V outputs > 10 kΩ (to ground)

Mechanical Specifications

Connections Screw terminals for 0.5 mm² wires (AWG 20), stranded wires recommended

Housing material G-AISI10 (DIN 1725)

Bushing 8 ... 11 mm diameter cables (0.31 ... 0.43 in)

Humidity sensor protection (Ø 12 mm) PPS grid with steel netting

Weight

HMT300TMK with HMT337 8.7 kg (19.2 lb)

HMT300TMK with HMT337, packed in a wooden shipping box 13.3 kg (29.3 lb)

Compliance

IP rating IP65

NEMA rating NEMA 4

Operating Environment

Operating temperature for electronics -40 ... +60 °C (-40 ... +140 °F)

Storage temperature -55 ... +80 °C (-67 ... +176 °F)

EMC compliance EN61326-1, Industrial Environment

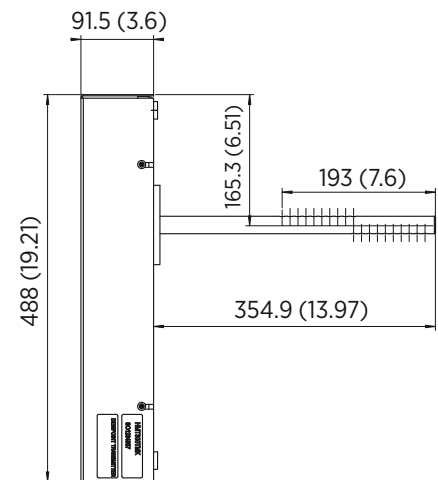
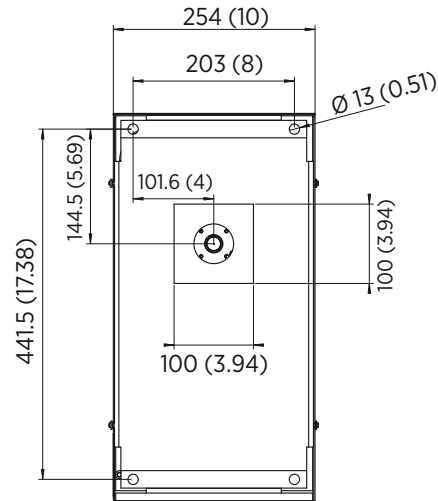

Dimensions in mm (inches)

VAISALA

www.vaisala.com



Features

- Measures dew point from -70 ... +80 °C (-94 ... +176 °F) with an accuracy of ± 2 °C (± 3.6 °F)
- Condensation-resistant
- Unique auto-calibration feature maintains accuracy over long term
- Compatible with Vaisala DRYCAP® Hand-Held Dewpoint Meter DM70
- Traceable calibration to measurements and analog outputs (certificates included)
- Graphical display and keypad for convenient operation
- Optional alarm relays and mains power supply module
- Up to three analog outputs, RS-232/485, LAN
- Modbus protocol support (RTU/ TCP)

Vaisala DRYCAP® Dewpoint and Temperature Transmitter Series DMT340 is designed for industrial low-humidity applications such as industrial drying, compressed air systems, semiconductor industry, dry rooms, baking ovens, and metal heat treatment.

Vaisala DRYCAP® Sensor Benefits

- Accurate and reliable measurement
- Excellent long-term stability
- Fast response time
- Resistant to environmental factors and condensation

Stability at Low Dew Points

The Vaisala DRYCAP® sensor is immune to particulate contamination, water condensation, oil vapor, and most chemicals. The sensor is condensation resistant and recovers perfectly if exposed to liquid water. Fast reaction time and stability make its performance unmatched also in dynamic and low dew point applications.

Graphical Display of Measurement Data and Trends for Convenient Operation

The DMT340 features a large numerical and graphical display with a multilingual menu and keypad. It allows users to easily monitor operational data, measurement trends, and access measurement history for the past 12 months.

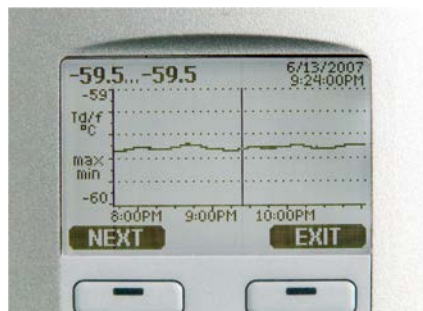

The display shows measurement trends, real-time data, and measurement history.

Versatile Outputs and Data Collection

The DMT340 can support up to three isolated analog outputs. Optional AC mains power and relay outputs are also available.

In addition to the analog outputs, the DMT340 supports Modbus RTU and TCP/IP communication protocol.

The data logger, with real-time clock and battery backup, guarantees reliable logging of measurement data for over four years. The display alarm allows tracking of any measured parameter, with freely configurable low and high limits. The recorded data can be viewed on the local display or transferred to a PC with Microsoft Windows® software. The transmitter can also be connected to a network with an optional LAN interface, which enables an Ethernet connection. A

USB service cable makes it easy to connect the DMT340 to a PC via the service port for modifying settings or reading logged data.

Easy Installation

With multiple options to choose from, the instrument can be tailored to meet the specific needs of each individual application and is delivered installation-ready and pre-configured for each delivery. Quick delivery time and global service network make DMT340 a perfect choice for any project.



The Vaisala DRYCAP® Hand-Held Dewpoint Meter DM70 is ideal for fieldchecking DMT340 transmitters.

	DMT342	DMT344	DMT347	DMT348
Pressure range	0 ... 50 bar/0 ... 725 psia	0 ... 50 bar/0 ... 725 psia	0 ... 10 bar/0 ... 145 psia	0 ... 40 bar/0 ... 580 psia
Mechanical durability	up to 250 bar/ 3625 psia	up to 100 bar/1450 psia	up to 10 bar/145 psia	up to 70 bar/1015 psia
Probe diameter	12 mm/0.5 in	12 mm/0.5 in	12 mm/0.5 in	12 mm/0.5 in
Installation	Flange 36 mm/1.4 in	Fitting body M22 x 1.5 Fitting body NPT 1/2 in	Fitting body R 3/8 in ISO Fitting body G 1/2 in ISO Fitting body NPT 1/2 in	Fitting body R1/2 in ISO Fitting body NPT 1/2 in
Ball-valve set				BALLVALVE-1
Sampling cell	HMP302SC			DMT242SC or DMT242SC2

DMT340 Series Dewpoint and Temperature Transmitters for Very Dry Conditions

DMT341 for Installations in Dry Spaces



DMT341 display shows measurement trends, real-time data, and measurement history. DMT341 is made for installations in dry rooms where the entire dew point transmitter needs to be inside the dry space. The concept is easy to clean and suitable also for cleanrooms.

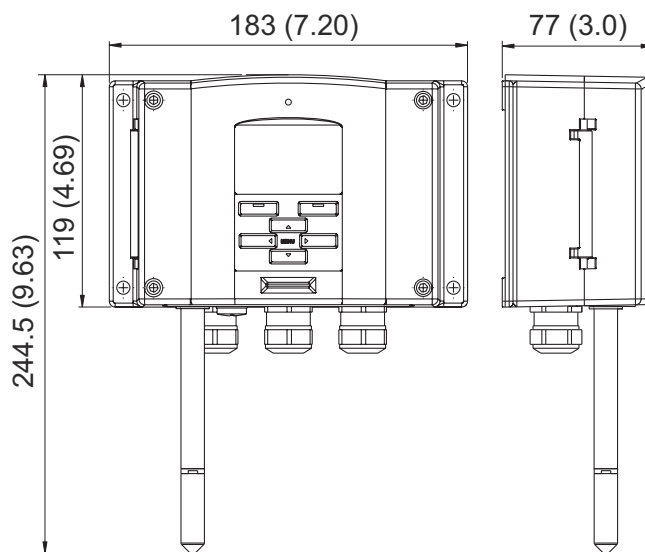

DMT341 dimensions in mm (inches)

DMT342 with Small Size Flanged Probe



The DMT342 probe is installed using a flange or sampling cell. The small probe is ideal for integration into larger equipment or applications with high pressures.

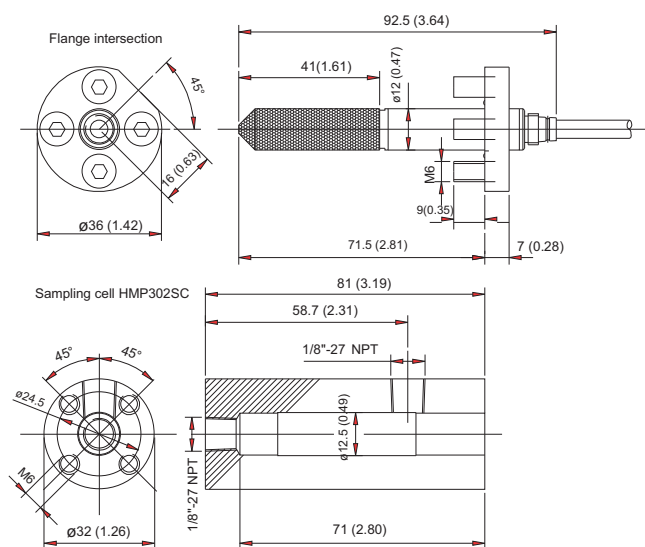

DMT342 dimensions in mm (inches)

DMT344 with Probe for High Pressures

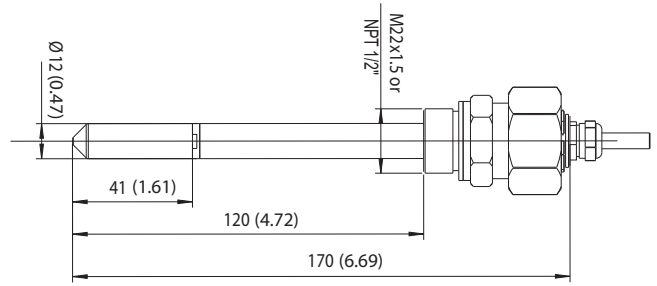

DMT344 dimensions in mm (inches)

The DMT344 features a threaded connection for extended pressures with different fitting-body options. It is ideal for permanent installation into pressurized or vacuum processes.

DMT347 with Small-Sized Probe

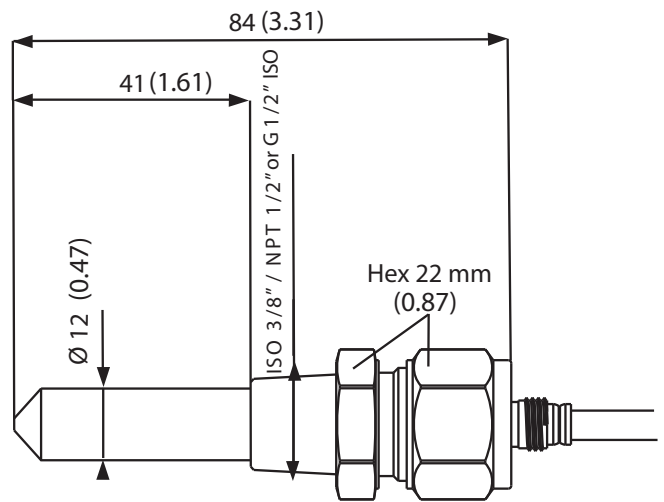

DMT347 dimensions in mm (inches)

The DMT347 probe is ideal for pressurized or vacuum applications in tight spaces. The small probe is installed using Swagelok® connectors.

DMT348 with Probe for Pipeline Installations

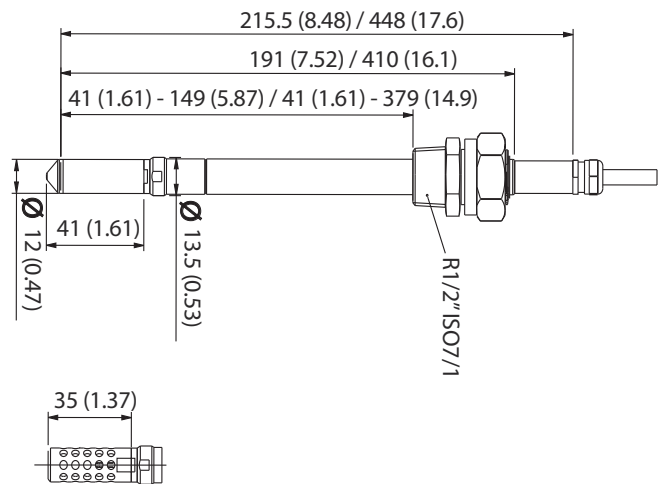
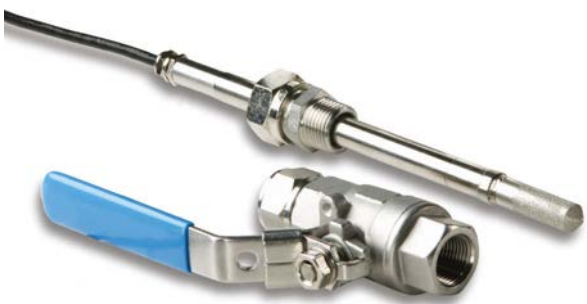

The DMT348 is ideal for installation into pressurized or vacuum processes where the probe needs to be able to be removed while the process is running. The probe depth is adjustable.

Optional filter for low pressures, suitable for all models, dimensions in mm (inches). Optional filter provides faster gas exchange to the sensor in applications where protection from particulates is not needed.

DMT340 Series Technical Data

Measurement Performance

Dew Point

Sensor	Vaisala DRYCAP® 180M
Measurement range	-70 ... +80 °C (-94 ... +176 °F) T _d
Measurement range for continuous use	-70 ... +45 °C (-94 ... +113 °F) T _d
Accuracy up to 20 bar/290 psia	±2 °C/±3.6 °F (see the accuracy graph below)
Accuracy, 20 ... 50 bar/290 ... 725 psia	additional inaccuracy +1 °C T _d

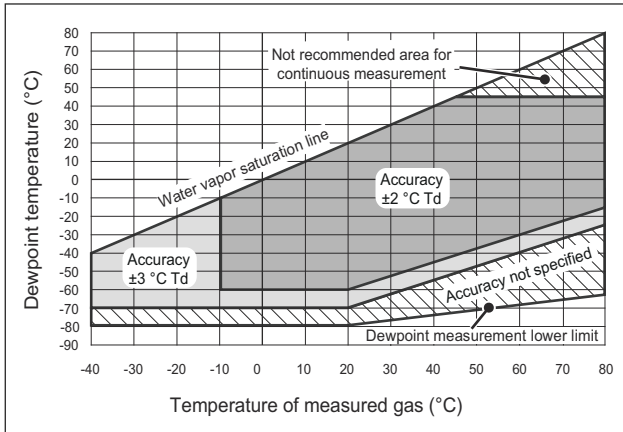

Dew Point Accuracy vs. Measurement Conditions

Response time	63% [90%] at +20 °C gas temperature
T63 [T90] response times at 20 °C and 1 l/min flow:	
-60 ... -20 °C T _d (-76 ... -4 °F T _d)	5 s [10 s]
-20 ... -60 °C T _d (-4 ... -76 °F T _d)	45 s [10 min]

Temperature

Measurement range	0 ... +80 °C (+32 ... +176 °F)
Accuracy	±0.2 °C at room temperature
Temperature sensor	Pt100 RTD Class F0.1 IEC 60751

Relative Humidity

Measurement range	0 ... 70 %RH
Accuracy (RH <10 %RH, at +20 °C)	±0.004 %RH + 20% of reading

Concentration by Volume (ppm)

Measurement range (typical)	10 ... 2500 ppm
Accuracy (at +20 °C, 1 bar)	1 ppm + 20% of reading

Other measurement parameters available (model-dependent): mixing ratio, absolute humidity, pressure dew point calculated to 1 bar, temperature difference (T-T_d), water vapor pressure

Operating Environment

Operating temperature for probes	-40 ... +80 °C (-40 ... +176 °F)
Mechanical durability	up to +180 °C (+356 °F)
Mechanical durability of transmitter body	40 ... +60 °C (-40 ... +140 °F)
Mechanical durability with display	0 ... +60 °C (+32 ... +140 °F)
Storage temperature range	-55 ... +80 °C (-67 ... +176 °F)
Pressure range for probes	see probe specifications
Sample flow rate	no effect
Measured gases	non-corrosive gases
Electromagnetic compatibility	Complies with EMC standard EN61326-1, Industrial environment

Note: Transmitter with display test impedance of 40 Ω is used in IEC61000-4-5 (Surge immunity)

Inputs and Outputs

Operating voltage	10 ... 35 VDC, 24 VAC ±20 %
with optional power supply module	100 ... 240 VAC 50/60 Hz

Power Consumption at 20 °C (U_{in} 24VDC)

RS-232	max. 25 mA
U _{out} 2 x 0 ... 1V / 0 ... 5 V / 0 ... 10 V	max. 25 mA
I _{out} 2 x 0 ... 20 mA	max. 60 mA
display and backlight	+ 20 mA
during sensor purge	max. + 110 mA

Analog Outputs (2 Standard, 3rd Optional)

current output	0 ... 20 mA, 4 ... 20 mA
voltage output	0 ... 1 V, 0 ... 5 V, 0 ... 10 V
Accuracy of analog outputs at 20 °C	0.05% full scale
Temperature dependence of the analog outputs	± 0.005%/°C full scale

External Loads

current outputs	RL < 500 Ω
0 ... 1 V output	RL > 2 kΩ
0 ... 5 V and 0 ... 10V outputs	RL > 10 kΩ
Wire size	0.5 ... 2.5 mm ² (AWG 20 ... 14) stranded wires recommended

Digital outputs	RS-232, RS-485 (optional)
Protocols	ASCII commands, Modbus RTU
Service connection	RS-232, USB
Relay outputs	0.5 A, 250 VAC, SPDT (optional)

Ethernet Interface (Optional)

Supported standards	10BASE-T, 100BASE-TX
Connector	8P8C (RJ45)
IPv4 address assignment	DHCP (automatic), static
Protocols	Telnet, Modbus TCP/IP

WLAN Interface (Optional)

Supported standards	802.11b
Antenna connector type	RP-SMA
IPv4 address assignment	
Protocols	Telnet, Modbus TCP/IP
Security	WEP 64/128, WPA 2/802.11i

Authentication / Encryption (WLAN)

Open / no encryption	
Open / WEP	
WPA Pre-shared key / TKIP	
WPA Pre-shared key / CCMP (a.k.a. WPA2)	

Optional Data Logger with Real-Time Clock

Logged parameters	max. three with trend/min./max. values
Logging interval	10 sec. (fixed)
Max. logging period with max. temporal resolution	4 years, 5 months
Logged points	13.7 million points per parameter
Battery lifetime	min. 5 years
Display	LCD with backlight, graphical trend display of any parameter
Menu languages	English, Chinese, Finnish, French, German, Japanese, Russian, Spanish, Swedish

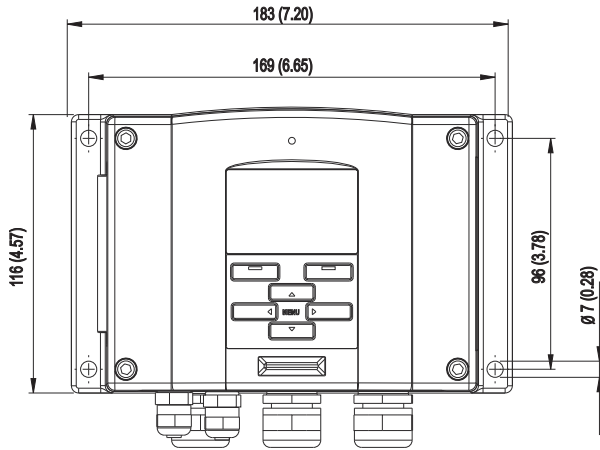
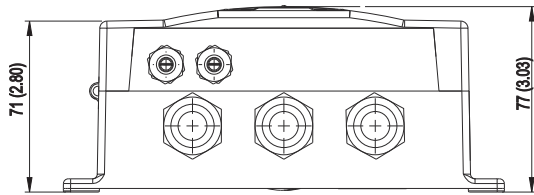

Dimensions in mm (inches)

Mechanical Specifications

Cable bushing M20x1.5 for cable diameter 8 ... 11mm/
0.31 ... 0.43"

Conduit fitting 1/2" NPT

User cable connector (optional) M12 series 8-pin (male)

option 1 female plug with 5 m (16.4 ft.) black cable

option 2 female plug with screw terminals

USB-RJ45 Serial Connection Cable 219685

Probe cable diameter 5.5 mm

Standard probe cable lengths 2 m, 5 m, or 10 m

(Additional cable lengths available, see order forms for details)

Housing material G-AlSi 10 Mg (DIN 1725)

Housing classification IP66

IP65 (NEMA4X) with local display

Weight (depending on selected probe, cable and modules) 1.0 - 3.0 kg



Features

- DMT345 measures humidity at temperatures up to 180 °C (356 °F)
- DMT346 measures humidity at temperatures up to 350 °C (+662 °F)
- Dew point accuracy ± 2 °C (± 3.6 °F)
- Condensation-resistant
- Unique auto-calibration feature
- Analog outputs, RS-232/485, WLAN/LAN
- Modbus protocol support (RTU/TCP)

Vaisala DRYCAP® Dewpoint Transmitters DMT345 and DMT346 are designed for humidity measurement in industrial drying applications with particularly high temperatures.

Benefits

- Vaisala DRYCAP® sensor provides accurate and reliable measurement with excellent long-term stability and fast response time
- Graphical display and keypad for convenient operation
- Optional alarm relays and mains power supply module

Both transmitters incorporate the Vaisala DRYCAP® sensor, which is accurate, reliable, and stable. The sensor is condensation-resistant and is immune to particulate contamination, oil vapor, and most chemicals. The DRYCAP® sensor is notable for its swift response time and rapid recovery after getting wet.

Measure Humidity Directly in Hot Processes

DMT345 and DMT346 are built for direct measurement in hot processes. Therefore, there is no need for sampling systems and trace heating. As a result, high measurement accuracy and constancy are maintained.

The accuracy and stability of DMT345 and the DMT346 are due to their unique auto-calibration function, developed by Vaisala. This feature allows the transmitter to perform calibration and adjustment by itself while the measured process is running. If the measurement accuracy is not confirmed, corrections are made automatically. The procedure is so quick and corrections so minor that it causes no disruption, ensuring easy maintenance and high performance.

DMT345: Accurate in Hot and Dry Environments

DMT345 is designed for accurate humidity measurement in hot and dry conditions. This model provides unmatched dry-end measurement accuracy at temperatures up to 140 °C; however, it can operate safely at temperatures up to 180 °C.

The long and robust steel probe and an optional installation flange allow easy, adjustable installation depth through insulation for example in ovens.

DMT346: Reliable in Very Hot Processes

DMT346 provides the best measurement performance at process temperatures between 140 °C and 350 °C.

DMT346 includes a cooling set as standard. The cooling set provides passive cooling by conducting heat away from the probe and thus reduces temperature to optimal range for the sensor.

The cooling system has no moving parts, and requires no additional power or cooling utilities, so there is no risk of sensor damage due to mechanical cooling failure.

Additionally, sensor warming minimizes the risk of condensation accumulating on the sensor. In low humidity conditions the combination of auto-calibration and DRYCAP® ensures accurate measurement.

Graphical Display of Measurement Data and Trends for Convenient Operation

DMT345 and DMT346 transmitters feature a large numerical and graphical display with a multilingual menu and keypad. It allows users to easily monitor operational data, measurement trends, and access measurement history for the past 12 months.

The optional data logger, with real-time clock, makes it possible to generate over four years of measurement history and zoom in on any desired time or time frame.

The display alarm allows tracking of any measured parameter, with freely configurable low and high limits.

Versatile Outputs and Data Collection

DMT345 and DMT346 transmitters can support up to three analog outputs; an isolated galvanic power supply and relay outputs are also available.

For serial interface the USB connection, RS-232, and RS-485 can be used. DMT345 and DMT346 are also capable of applying the Modbus communication protocol and, together with an appropriate connection option, provide either Modbus RTU (RS-485) or Modbus TCP/IP (Ethernet) communication.

The data logger, with real-time clock and battery backup, guarantees reliable logging of measurement data for over four years. The recorded data can be viewed on the local display or transferred to a PC with Microsoft Windows software. The transmitter can also be connected to a network with an optional LAN interface, which enables an Ethernet connection. A USB service cable makes it easy to connect DMT345/346 to a PC via the service port.

With multiple options to choose from, the instrument can be tailored to meet the specific needs of each individual application and is delivered

installation-ready and pre-configured for each delivery. Quick delivery time and global service network make DMT340 series a perfect choice for any project.

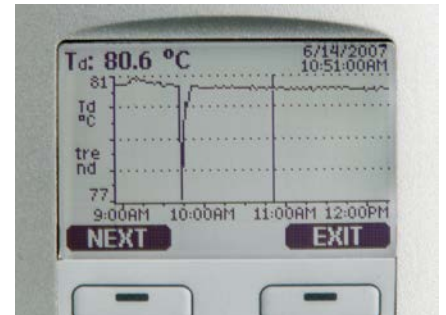

The large graphical display allows the user to check data at a glance.

Technical Data

Measurement Performance, DMT345

Dew Point

Sensor	Vaisala DRYCAP 180S
Measurement range	-40 ... +100 °C (-40 ... +212 °F) T _d
Accuracy	±2 °C (±3.6 °F) T _d See the accuracy graph below

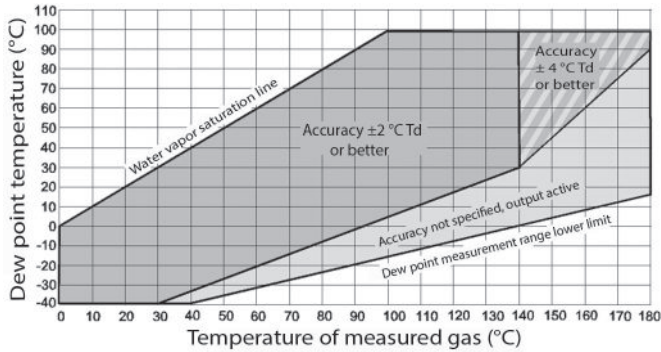

Dew point accuracy vs. measurement conditions

Response time 63 % [90 %] in flow rate 1 l/min and 1 bar pressure	From dry to wet: 5 s [10 s] From wet to dry including auto-calibration 45 s [5 min]
---	--

Temperature

Measurement range	0 ... +180 °C (+32 ... +356 °F)
Measurement range with sensor warming	Upper range limited by humidity (at 80 %RH warming is switched on and T reading not actual process temperature)
Accuracy	±0.4 °C at 100 °C
Temperature sensor	Pt100 RTD Class F0.1 IEC 60751

Relative Humidity

Measurement range	0 ... 100 %RH
Measurement range with sensor warming	0 ... 80 %RH
Accuracy below 10 %RH	±10 % of reading
Accuracy above 10 %RH	±1.5 %RH + 1.5 % of reading

Mixing Ratio

Measurement range (typical)	0 ... 1000 g/kg (0 ... 7000 gr/lbs)
Accuracy (typical)	±12 % of reading

Measurement Performance, DMT346

Dew Point

Sensor	Vaisala DRYCAP 180S
Measurement range	-25 ... +100 °C (-13 ... +212 °F) T _d
Accuracy	±2 °C (±3.6 °F) T _d See the accuracy graph below

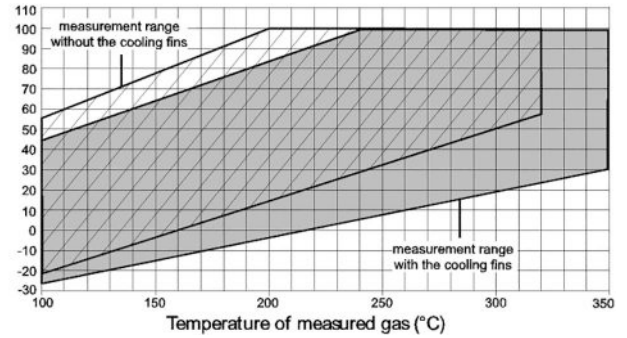

Dew point accuracy vs. measurement conditions

Response time 63 % [90 %] in flow rate 1 l/min and 1 bar pressure	From dry to wet: 5 s [10 s] From wet to dry including auto-calibration 45 s [5 min]
---	--

Mixing Ratio

Measurement range (typical)	0 ... 1000 g/kg (0 ... 7000 gr/lbs)
Accuracy (typical)	±12 % of reading

Inputs and Outputs, DMT345 and DMT346

Accuracy of analog outputs at 20 °C	± 0.05% full scale
Temperature dependence of analog outputs	± 0.005%/°C full scale
Max. wire size	0.5 mm2 (AWG 20) stranded wires recommended
Digital outputs	RS-232, RS-485 (optional)
Protocols	ASCII commands, Modbus RTU
Service connection	RS-232, USB
Relay outputs 2+2 pcs (optional)	0.5 A, 250 VAC, SPDT
Operating voltage	10 ... 35 VDC, 24 VAC ±20%
Operating voltage with optional power supply module	100 ... 240 VAC 50/60 Hz
Default Start-up Time	
Initial reading after power-up	3 s
Full operation after sensor purge and autocalibration	Approx. 6 min
Power Consumption at 20 °C (U_{in} 24 VDC)	
U _{out} 2x0 ... 1V/0 ... 5V/0 ... 10V	max. 25 mA
I _{out} 2x0 ... 20mA	max. 60 mA
RS-232	max. 25 mA
Display and backlight	+ 20 mA
During sensor purge	max. + 110 mA
Analog Outputs (2 Standard, 3rd Optional)	
Current output	0 ... 20 mA, 4 ... 20 mA
Voltage output	0 ... 1 V, 0 ... 5 V, 0 ... 10 V
External Loads	
Current outputs	R _L < 500 Ω
0 ... 1V output	R _L > 2 kΩ
0 ... 5V and 0 ... 10V outputs	R _L > 10 kΩ
Ethernet Interface (Optional)	
Supported standards	10BASE-T, 100BASE-TX
Connector	8P8C (RJ45)
IPv4 address assignment	DHCP (automatic), static
Protocols	Telnet, Modbus TCP/IP
WLAN Interface (Optional)	
Supported standards	802.11b
Antenna connector type	RP-SMA
IPv4 address assignment	DHCP (automatic), static
Protocols	Telnet, Modbus TCP/IP
Security	WEP 64/128, WPA WPA2/802.11i
Authentication / Encryption (WLAN)	Open / no encryption Open / WEP WPA Pre-shared key / TKIP WPA Pre-shared key / CCMP (a.k.a. WPA2)
Optional Data Logger with Real-time Clock	
Logged parameters	Max. four with trend/min/max values
Logging interval	10 sec. (fixed)
Max. logging period	4 years, 5 months
Logged points	13.7 million points per parameter
Battery lifetime	Min. 5 years
Display	LCD with backlight, graphical trend display
Menu languages	English, Chinese, Finnish, French, German, Japanese, Russian, Spanish, Swedish

Operating Environment, DMT345 and DMT346

Storage temperature	-55 ... +80 °C (-67 ... +176 °F)
Pressure range for probes	Slight pressure difference (- 200 mbar)
Measured gases	Non-corrosive gases
EMC compliance	EN61326-1, Industrial environment ¹⁾
Mechanical Durability	
Of probes	Up to +180 °C (+356 °F) for DMT345 Up to +350 °C (+662 °F) for DMT346
Of transmitter body	-40 ... +60 °C (-40 ... +140 °F)
With display	0 ... +60 °C (32 ... +140 °F)

¹⁾ Note: Transmitter with display test impedance of 40 ohm is used in IEC61000-4-5 (Surge immunity)

Mechanical Specifications, DMT345 and DMT346

Cable bushing	M20 x 1.5 for cable diameter 8 ... 11 mm / 0.31 ... 0.43"
Conduit fitting (optional)	1/2"NPT
Housing material	G-AISI 10 Mg (DIN 1725)
IP rating	IP66 IP65 (NEMA4X) with local display
Weight (depending on selected probe, cable, and modules)	1.0 – 3.0 kgs (2.2-6.6 lbs)
USB-RJ45 Serial Connection Cable	219685
Probe cable diameter	5.5 mm (0.2 in)
Standard probe cable lengths	2 m, 5 m or 10 m (Additional cable lengths available, please see order forms for details)
User cable connector (optional)	M12 series 8-pin (male)
option 1	female plug with 5 m (16.4 ft) black cable
option 2	female plug with screw terminals

Dimensions in mm (inches)

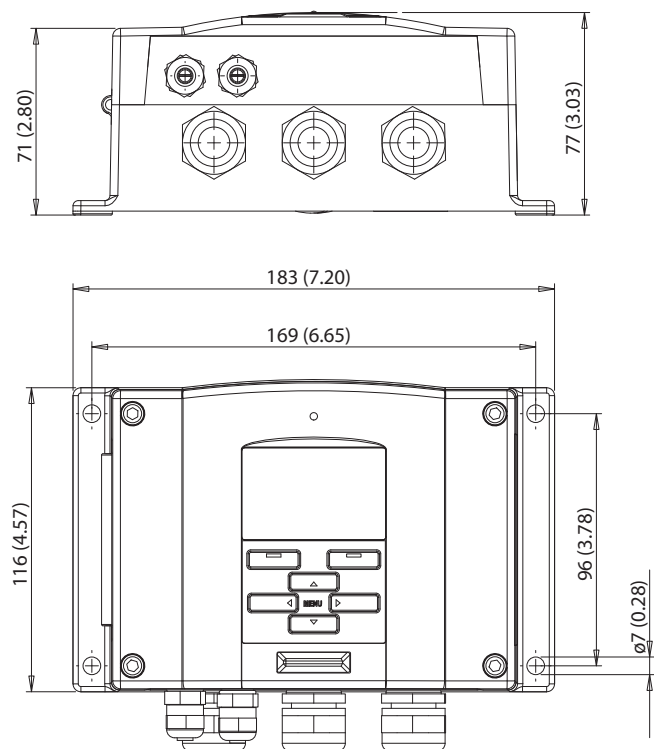

DMT345 and DMT346 Transmitter Housing

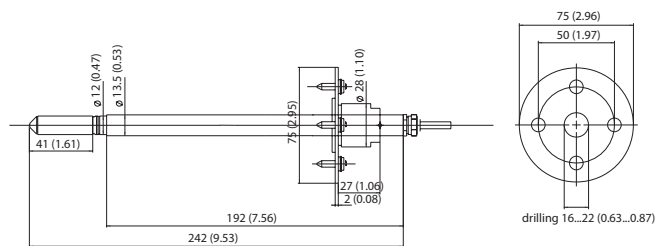

DMT345 Probe and Mounting Flange

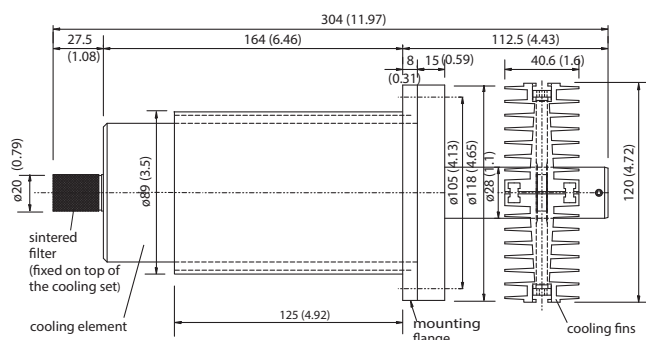

DMT346 Cooling Set

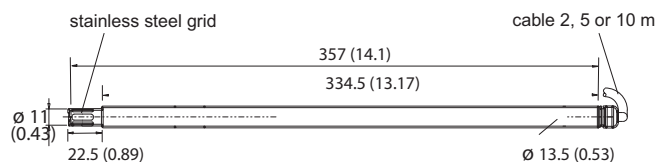

DMT346 Probe

DMT152 Dew Point Transmitter

For Low Dew Point Measurement in OEM Applications



Features

- Vaisala DRYCAP® technology with a polymer sensor
- Measures dew point down to -80 °C (-112 °F)
- Withstands condensation
- Traceable calibration (certificate included)
- Applications: dry chambers, dry gases, semiconductor manufacturing, research and testing, and compressed air

The Vaisala DRYCAP® Dewpoint Transmitter DMT152 is designed for measuring low dew point in OEM applications, even down to -80 °C . The excellent long-term stability and reliability of its performance is based on the latest DRYCAP® polymer sensor technology.

Low Maintenance

The DMT152 mechanics have been designed for harsh environments requiring protection against dust, dirt, and splashed water. The DRYCAP® technology has a low maintenance need due to its excellent long-term stability and durability against condensation.

Applications

The DMT152 is an ideal choice for industrial applications where it is necessary to control very low humidity. Most typical areas of use are air and plastics dryers, dry chambers, dry gases, and high-voltage circuit breakers.

The DMT152 measures accurately and reliably also in the challenging combination of low humidity and hot air, which is typical in plastics drying.

Benefits

- Accurate
- Compact and powerful
- Fast response time
- Reduced maintenance costs due to long calibration interval

Technical Data

Measurement Performance

Sensor	Vaisala DRYCAP® 180U Thin-film capacitive polymer sensor
Recommended calibration interval	2 years
Dew Point Temperature	
Measurement range	-80 ... -10 °C (-112 ... +14 °F) T _d
Accuracy	
-80 ... -40 °C (-112 ... -40 °F)	±2 °C (3.6 °F) T _d
-40 ... -20 °C (-40 ... -4 °F)	±3 °C (5.4 °F) T _d
Non-calibrated range	-100 ... +20 °C (-148 ... +68 °F) T _d

Accuracy over temperature range:

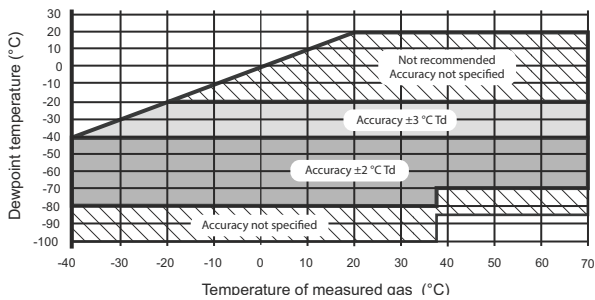

Typical response time 63 % [90 %] at a gas temperature of +20 °C (+68 °F) and pressure of 1 bar:	
-10 ... -80 °C T _d	0.5 min [7.5 min]
-80 ... -10 °C T _d	2 s [5 s]
Typical long-term stability	Better than 2 °C (3.6 °F) /year
Concentration by Volume (ppm)	
Measurement range (typical)	0 ... 500 ppm
Accuracy at +20 °C (+68 °F), 1013 mbar	±(0.2 ppm + 20 % of reading)

Operating Environment

Temperature	-40 ... +70 °C (-40 ... +158 °F)
Relative humidity	0 ... 100 %RH (up to +20 °C/+68 °F)
Pressure	0 ... 50 bar (725 psia)
Measured gases	Non-corrosive gases
Sample flow rate	No effect on measurement accuracy

Accessories

Connection cable for MI70 hand-held indicator	219980
USB cable for pc connection	219690
NW40 flange	225220SP
Sampling cells (available for ISO G $\frac{1}{2}$ ")	
basic sampling cell	DMT242SC
with Swagelok 1/4" male connectors	DMT242SC2
with a quick connector and leak screw	DSC74
two-pressure sampling cell	DSC74B

Inputs and Outputs

Two analog outputs (scalable)	4 ... 20 mA, 0 ... 20 mA (3 wire) 0 ... 5 V, 0 ... 10 V
Accuracy of analog outputs	±0.01 V / ±0.01 mA
Digital output	RS-485 (2-wire)
Alarm-level indication by analog signal	User selectable
Purge information	5 V, 10 V, 20 mA or LED
Operating Voltage	
RS-485 output	11 ¹⁾ ... 28 VDC
voltage output	15 ¹⁾ ... 28 VDC
current output	21 ... 28 VDC
Supply Current	
normal measurement	20 mA + load current
during self-diagnostics	Max. 220 mA pulsed
Supply voltage fluctuation	Max. 0.3 V
External Load	
voltage output	Min. 10 kΩ
current output	Max. 500 Ω

1) For extended temp. down to -40 °C (-40 °F) or pressure up to 50 bar (725 psia), the supply voltage is 21 ... 28 VDC.

Mechanical Specifications

Housing material (wetted parts)	AISI316L
Stainless steel mesh filter	Filter body AISI303, mesh AISI316L, grade 18 μm
Mechanical connections	ISO G $\frac{1}{2}$ ", NPT $\frac{1}{2}$ ", UNF 3/4"- 16"
Housing classification	IP66
Storage temperature range	-40 ... +80 °C (-40 ... +176 °F)
Weight (ISO G $\frac{1}{2}$ ")	190 g (6.70 oz)
Complies with EMC standard EN61326-1, Electrical equipment for measurement control and laboratory use - EMC requirements; Industrial environment	

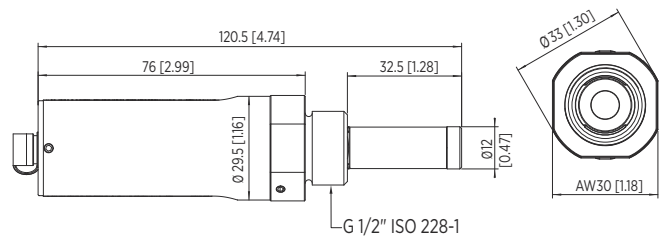

Dimensions in mm (inches)



DMT143 Miniature Dew Point Transmitter

For OEM Applications



Features

- Miniature size dew point transmitter for e.g. small industrial dryer applications
- Vaisala DRYCAP® technology with auto-calibration
- Calibration interval of two years
- Dew point measurement range -70 ... +60 °C (-94 ... +140 °F)
- Accuracy ± 2 °C (± 3.6 °F)
- Withstands condensation
- Compatible with Vaisala DRYCAP® Hand-Held Dewpoint Meter DM70
- Traceable calibration
- Easy servicing and data transfer via RS-485 user interface
- LED alarm for exceeded dew point level
- Fast response time

Vaisala DRYCAP® Dewpoint Transmitter DMT143 is an ideal choice for small compressed air dryers, plastic dryers and other OEM applications.

Vaisala DRYCAP®

Vaisala DRYCAP® Dewpoint Transmitter DMT143 is a miniature dew point measurement instrument.

The transmitter can be installed directly into pressurized systems at 50 bar (725 psia) maximum pressure. The long-term high performance is achieved with Vaisala DRYCAP® technology.

The sensor fully withstands getting wet, and therefore, the transmitter performs exceptionally well in applications that occasionally experience process water spikes, such as pipeline condensation during a system failure or start-up.

The sensor is also highly resistant to particulate contamination, oil vapor and most chemicals, and is insensitive to the flow rate.

Long Calibration Interval

The calibration interval of DMT143 is two years. Additionally, Vaisala DRYCAP® Hand-Held Dewpoint Meter DM70 can be used to confirm the performance of DMT143 without disconnecting the transmitter. For any adjustment needs, the transmitter can be sent to Vaisala Service.

The auto-calibration software works on-line while the process is running. If the measurement accuracy is not confirmed, corrections are made automatically.

Easy Installation

DMT143 has a variety of features to choose from, including different output, installation options and alarm LED.

Due to its small size and light weight, DMT143 is quickly and easily installed in tight spaces or in small-size pipelines. The alarm LED indicates too high dew point in the process. The trigger point is preset at the factory. It can be later adjusted with Vaisala DRYCAP® Hand-Held Dewpoint Meter DM70 or a computer.

Technical Data

Measurement Performance

Sensor	Vaisala DRYCAP® 180D
Sensor protection	Stainless steel sintered filter
Recommended calibration interval to confirm the specified accuracy	2 years
Dew Point Temperature	
Measurement range (typical)	-70 ... +60 °C (-94 ... +140 °F) T _d
Accuracy in air or N ₂ ¹⁾	±2 °C (±3.6 °F) T _d (see graph below)

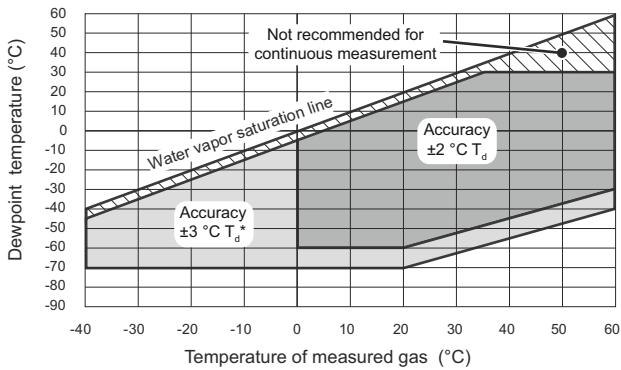

* > 12 bar, accuracy ±4 °C T_d

Analog output scalings:	
Option 1	-80 ... +20 °C (-112 ... +68 °F) T _d
Option 2	-80 ... +20 °C (-112 ... +68 °F) T _d dew point at ambient pressure
Option 3	Free scaling
Response time 63% [90%] at +20 °C gas temperature and 1 bar pressure:	
-60 → -20 °C T _d (-76 → -4 °F T _d)	5 s [15 s]
-20 → -60 °C T _d (-4 → -76 °F T _d)	45 s [10 min]
Water Concentration by Volume (ppm)	
Measurement range (typical)	10 ... 40 000 ppm
Accuracy at +20 °C (+68 °F), 1 bar	1 ppm + 20 % of reading

¹⁾ When the dew point is below 0 °C (32 °F), the transmitter outputs frost point.

Operating Environment

Measured gases	Non-corrosive gases
Temperature ¹⁾	-40 ... +60 °C (-40 ... +140 °F)
Relative humidity	0 ... 100 % RH
Pressure ¹⁾	0 ... 50 bara (725 psia)
Sample flow rate	No effect for measurement accuracy
Storage temperature	-40 ... +60 °C (-40 ... +140 °F)

¹⁾ For extended temperature below 0 °C (+32 °F) or pressure above 20 bara (290 psia) the supply voltage must be 24 ... 28 VDC.

Inputs and Outputs

Analog output (scalable)	4 ... 20 mA (3-wire), 0 ... 1 V / 5 V, 1 ... 5 V
Resolution for current output	0.002 mA
Resolution for voltage output	0.3 mV
Accuracy for current output at +20 °C	+/- 0.05 mA
Accuracy for voltage output at +20 °C	+/- 0.01 V
Operating voltage with voltage output	12 ... 28 VDC
Operating voltage with current output	18 ... 28 VDC
Load for current output	Max. 500 Ω
Load for voltage output	Min. 10 kΩ
Typical temperature dependence	0.005 % of span/°C
Digital output	RS-485, non-isolated Vaisala Industrial Protocol
Connector	4-pin M8 (IEC 60947-5-2)
Supply Current	
Normal measurement	Max. 10 mA + load current
During self-diagnostics	Max. 220 mA pulsed

Mechanical Specifications

Mechanical connection	ISO G1/2 in or NPT 1/2
Housing material	Stainless steel (AISI316L)
Weight	G-thread version 90 g (3.2 oz) NPT-thread version 100 g (3.5 oz)

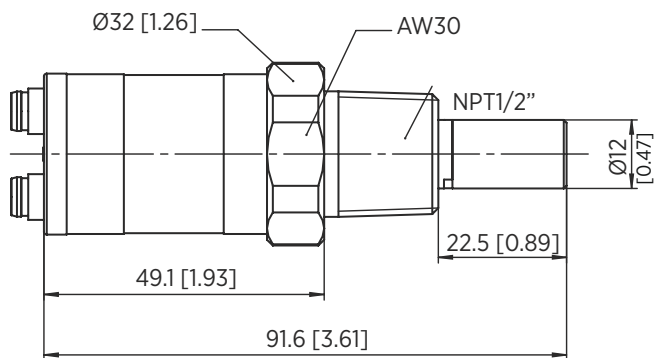
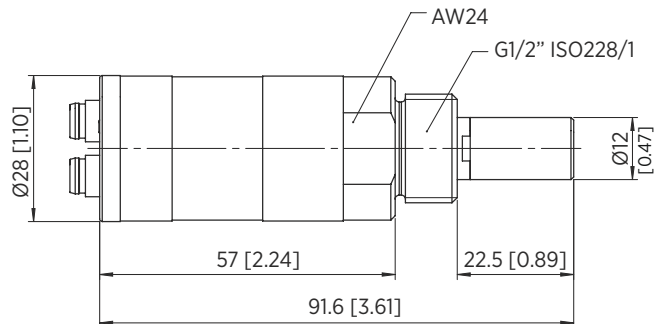

Dimensions in mm (inches)

Spare Parts and Accessories

Connection cable for DM70	219980SP
USB connection cable	219690
Loop powered external display	226476
Loop powered external display with relays	234759

Sampling Cells

Basic sampling cell	DMT242SC
With Swagelok 1/4 in male connectors	DMT242SC2
With quick connector and leak screw	DSC74SP
Two-pressure sampling cell	DSC74BSP
Cooling/venting coil	DMCOILSP

See DM70/Portable Sampling Systems and Sampling Cells for further information about sampling cells available.

Compliance

IP rating	IP66
NEMA rating	NEMA 4
EMC compliance	EN61326-1, Electrical equipment for measurement, control and laboratory use - EMC requirements - Industrial environment

DMT143L Dew Point Transmitter

For OEM Applications (DMT242 Replacement)



Features

- Ideal choice for industrial dryer applications
- Incorporates advanced Vaisala DRYCAP® Sensor and enhanced auto-calibration software
- Long-term stability in low dew points
- Fast response time
- Two sensor options cover dew point measurement range of -60 ... +60 °C (-76 ... +140 °F) with an accuracy of ± 2 °C (± 3.6 °F)
- Withstands condensation
- Traceable calibration (certificate included)
- Compatible with Vaisala DRYCAP® Hand-Held Dewpoint Meter DM70

Due to its wide measurement range and high long-term stability, DMT143L is an ideal choice for low dew point industrial applications such as compressed air dryers, plastic dryers, and other OEM applications.

Vaisala DRYCAP®

Vaisala DRYCAP® Dewpoint Transmitter DMT143L provides reliable and stable measurements for industrial dryer applications. It is designed for extreme conditions.

DMT143L incorporates Vaisala DRYCAP® thin film polymer sensor and auto-calibration software. The standard sensor choice for dry gases and desiccant dryers is DRYCAP® 180M and for more humid applications such as refrigeration dryers, a DRYCAP® 180S sensor. Both sensors are immune to particulate contamination, water condensation, oil vapor, and most chemicals.

Because the sensor withstands condensation, its performance is suitable for low dew point applications that experience process water spikes, such as pipeline condensation during a system failure or start-up.

The auto-calibration software works online while the process is running. If the measurement accuracy is not confirmed, corrections are made automatically. DMT143L adjusts the measurement, corrects dry-end drifts and continues to function. Calibration occurs quickly, and with corrections so minor, it will go unnoticed.

Compact, Rugged and Intelligent

Due to its compact size, DMT143L is quickly and easily installed in tight spaces.

Users can perform a field-check by using Vaisala DRYCAP® Hand-Held Dewpoint Meter DM70. The transmitter can be sent to Vaisala Service for traceable calibration. The recommended calibration interval is every two years.

Technical Data

Dew Point Temperature

Measurement range (typical) -60 ... +60 °C (-76 ... +140 °F)

Different analog output scalings available.¹⁾

Accuracy with DRYCAP® 180M ±2 °C (±3.6 °F) (see graph below)

1) When the dew point is below 0 °C (32 °F), the transmitter outputs frost point.

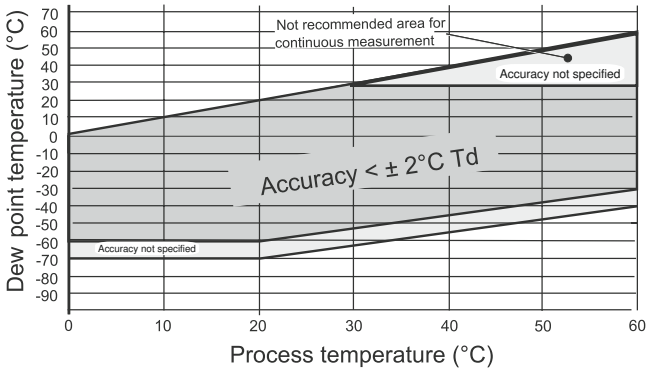

Dew Point Accuracy vs. Measurement Conditions

Response time 63% [90%] at +20 °C (+68 °F) gas temperature

Flow rate > 1 l/min and 1 bar pressure:

-60 → -20 °C T_d (-76 → -4 °F T_d) 5 s [10 s]

-20 → -60 °C T_d (-4 → -76 °F T_d) 45 s [10 min]

Accuracy with DRYCAP® 180S ±2 °C (±3.6 °F) (see graph below)

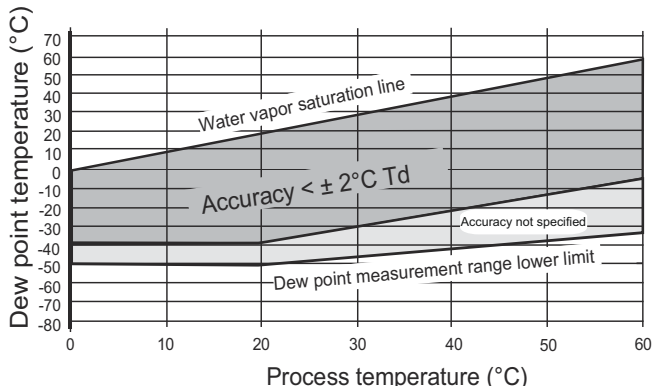

Operating Environment

Temperature 0 ... +60 °C (+32 ... +140 °F)

Higher temperature peaks Short-term OK

Relative humidity 0 ... 100 %RH

Pressure 0 ... 20 bara (0 ... 290 psia)

Sample flow rate No effect

Storage temperature -40 ... +60 °C (-40 ... +140 °F)

Inputs and Outputs

Analog output 4 ... 20 mA

Resolution for analog output ±0.002 mA

Accuracy for analog output at +20 °C +/- 0.05 mA

External load for analog output Max. 500 Ω

Typical temperature dependence 0.0008 mA/°C

Serial line for service use RS-485

Operating voltage 18 ... 28 VDC

Power consumption at 24 VDC Max. 220 mA

Mechanical Specifications

Probe material (wetted parts) Stainless steel (AISI 316L)

Sensor DRYCAP® 180M

Optimal sensor for refrigeration dryers DRYCAP® 180S

Sensor protection Stainless steel sintered filter (HM47280)

Electronics housing material Stainless steel

Mechanical connection G¹/₂ in ISO228-1 thread with bonded seal ring (U-seal)

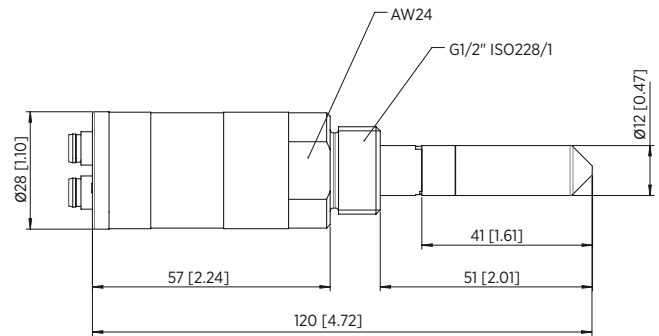

Dimensions in mm (inches)

Compliance

IP rating IP66

EMC compliance EN61326-1, Electrical equipment for measurement, control and laboratory use - EMC requirements; Industrial environment

VAISALA

www.vaisala.com



Features

- High accuracy $\pm 1\text{ }^{\circ}\text{C}$ ($\pm 1.8\text{ }^{\circ}\text{F}$) in the measurement range of refrigerant dryers
- Excellent long-term stability - resistant to compressor oil and most other chemicals thanks to HUMICAP® technology
- Low power requirements, 10 ... 28 VDC
- Easy to verify functionality with compatible Vaisala DM70 or HM70 hand-held meters
- Optional LED warning light

Vaisala HUMICAP® Dew Point Transmitter DMT132 is an affordable dew point measurement instrument designed to verify the functionality of refrigerant dryers. It is especially well suited for OEM dryer manufacturers.

Direct Measurement Cuts Costs

Direct outlet air dew point measurement provides accurate information about dryer functionality and is more reliable than the traditional method of measuring refrigerator temperature only. Knowledge of the real dew point ensures high quality compressed air at all times and enables customers to optimize dryer capacity. This helps to prevent investment in redundant dryer capacity and avoid unnecessary maintenance and costly malfunctions.

High Accuracy and Long-Term Stability

DMT132 provides optimal performance in the operating range of refrigerant dryers. In the measurement range of $-3\text{ }^{\circ}\text{C}$... $20\text{ }^{\circ}\text{C}$ ($+26.6\text{ }^{\circ}\text{F}$... $+68\text{ }^{\circ}\text{F}$), where the refrigerator

dryers typically operate, the T_d accuracy is $\pm 1\text{ }^{\circ}\text{C}$ ($\pm 1.8\text{ }^{\circ}\text{F}$). The instrument incorporates the proven Vaisala HUMICAP® sensor, which is resistant to compressor oil and most other chemicals, thereby providing excellent long-term stability.

Quick Installation and Easy Field Checking

It takes just a few minutes to install DMT132 directly into a dryer or compressed air line through a G1/2" ISO thread. Vaisala sampling cells can also be used. The loop-powered electronics mean that wiring is easy and power requirements are low. DMT132 operating voltages can be as low as 10 VDC.

Verifying the performance of DMT132 is easy with the compatible Vaisala DM70 or HM70 hand-held meters. The user can perform possible adjustments with Vaisala HMK15 Humidity Calibrator.



Demand for dew point sensors to verify refrigerant dryers is increasing. Direct dew point measurement enables energy savings and improved efficiency.

Technical Data

Measurement Performance

Measurement range	-30 ... +50 °C (-22 ... +122 °F) T_d
Accuracy at +20 °C (+68 °F)	±1 °C for -3 ... 20 °C (+26.6 ... +68 °F) T_d ¹⁾ ±2 °C for -15 ... -3 °C (+5 ... +26.6 °F) T_d ¹⁾ See accuracy graph below

Typical Response Time at 20 °C (+68 °F) Gas Temperature and 1 Bar Pressure

-14 → +3 °C (+7 → +37 °F) T_d	17 s (63 %) 40 s (90 %)
+3 → -14 °C (+37 → +7 °F) T_d	33 s (63 %) 85 s (90 %)

Calculated Variables

Dew point converted to atmospheric pressure $T_{d/ft}$ atm

¹⁾ When dew point is below 0 °C (+32 °F), the transmitter outputs frost point.

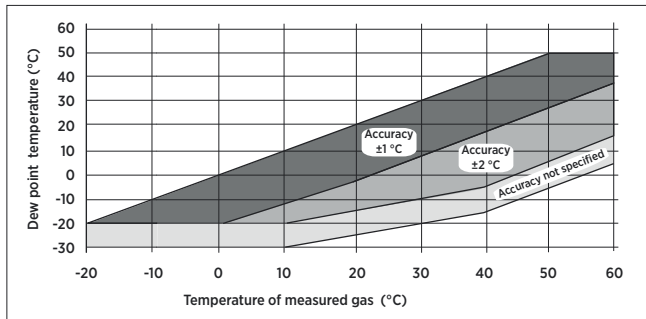

Operating Environment

Operating temperature	-30 ... +50 °C (-22 ... +122 °F)
Operating pressure	0 ... 20 bar
Relative humidity	0 ... 100 %RH
Sample flow rate	No effect on measurement accuracy
Measured gases	Non-corrosive gases
EMC compliance	EN61326-1, Industrial Environment

Outputs

Analog output (scalable)	4 ... 20 mA, 2-wire
Resolution for current output	0.002 mA
Accuracy of analog outputs at +20 °C	±0.05 % full scale
Typical temperature dependence	±0.005 % of full scale/ °C
Connector	4-pin M8 (IEC 60947-5-2)
LED indication available for defined dew point limit/error state indication RS-485 serial line for service use	

Mechanical Specifications

Sensor	Vaisala HUMICAP® 180R
Recommended calibration interval (in refrigerant dryer application)	2 years
Mechanical connection	G1/2" ISO
Operating voltage	10 ... 28 VDC
External load	Max. 100 Ω for supply voltages < 20 VDC Max. 500 Ω for supply voltages 20 ... 28 VDC
Weight	65 g (2.3 oz)
Housing material	PPS + 40 % GF
IP rating	IP65 (NEMA 4)
Storage temperature range	-40 ... +80 °C (-40 ... +176 °F)
Start-up time	3 s

Spare Parts and Accessories

Tube filter	230602
Special cover set for HMK15 (calibrator fitting DMT132 and HMP60)	230914
NPT Adapter	210662SP
Sample cells	DMT242SC, DMT242SC2, DSC74, DSC74B, DSC74C, DMCOIL
Duct installation flange	DM240FA
Cables (several lengths available)	HMP50Z032, HMP50Z300SP, HMP50Z500SP, HMP50Z1000SP
Loop powered external display	226476
USB service cable	219690
Connection cable to DM70/HM70	219980
LED plug	230388
ISO 1/2" plug	218773
NPT 1/2" plug	222507
Sealing ring set (3 pcs U-seal)	221525SP

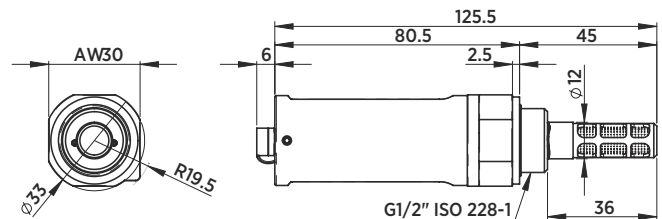

Dimensions in mm

VAISALA

www.vaisala.com



Features

- Designed for industrial spot-checking and field calibration
- Three models: accurate measurement ranges from -60 to +60 °C (-76 ... +140 °F)
- Vaisala DRYCAP® Sensor with unique autocalibration function
- Sensor withstands condensation
- Data can be logged and transferred to a PC via MI70 Link software
- Traceable calibration (certificate included)
- Fast response, enhanced by Sensor Purge option

Vaisala DRYCAP® Handheld Dewpoint Meter DM70 offers accurate and fast measurement for industrial dew point applications, such as compressed air, metal treatment and plastics drying.

Benefits

- Compact, small and light
- Intuitive user interface
- Low maintenance need due to superior long-term stability
- Sensor withstands condensation and fully recovers from getting wet

DM70 measures dew point temperature accurately over a wide measurement range. The probe may be inserted directly into pressurized processes, and it responds rapidly from ambient to process conditions. The DM70 meter is suitable for direct process dew point measurement in a wide temperature and pressure range. For more demanding applications, DM70 can be used with Vaisala sampling cell adapters or with Vaisala DRYCAP® Sampling System DSS70A.

Vaisala DRYCAP® Technology

DM70 is fitted with the Vaisala DRYCAP® Sensor. The sensor provides reliable, stable and high-performance dew point measurement. Autocalibration detects on-line possible measurement inaccuracies and automatically corrects dry-end drift in the calibration curve.

Three Probes to Choose From

Three probe models, all with autocalibration, are available. The A and B models are both general purpose probes. The C model is specifically developed for SF6 gas. The B and C probe models have an additional Sensor Purge feature that heats and dries the sensor, making the response from ambient to dry conditions exceptionally fast.

Intuitive User Interface

DM70 has a versatile and easy-to-use, menu-based user interface, a clear graphical LCD display, and datalogging capability. It can also be used as a tool for reading the output of fixed Vaisala dew point transmitters, such as DMT242, DMT132, DMT143, DMT152 and DMT340. DM70 displays one to three parameters at a time, either numerically or graphically. Several humidity units can be selected. In addition, DM70 includes conversion from gas pressure dew point to ambient pressure dew point. An analog output is also available.

MI70 Link

The optional MI70 Link Windows software and the USB connection cable form a practical tool for transferring logged data and real time measurement data from the DM70 to a PC.

DM70 Technical Data

Measurement Performance, DMP74A Probe

Dew Point

Measurement range (typical) -50 ... +60 °C (-58 ... +140 °F)

Dew Point Accuracy vs. Measurement Conditions

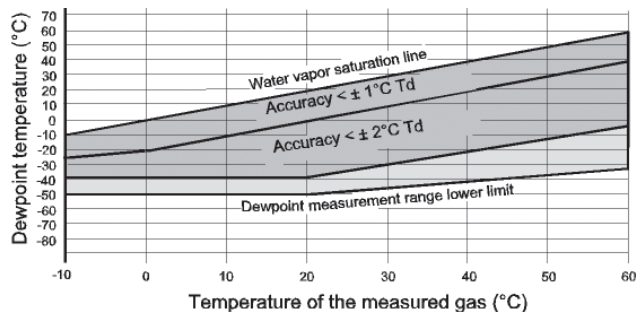

Accuracy (A probe) -40 ... +60 °C ±2 °C (±3.6 °F)
(see graph)

Response Time

Flow rate 0.2 m/s, 1 bar pressure, +20 °C (+68 °F) 63% [90%]

0 → -40 °C T_d (32 → -40 °F T_d) 20 s [120 s]

-40 → 0 °C T_d (-40 → 32 °F T_d) 10 s [20 s]

Dew point sensor Vaisala DRYCAP® 180S

Temperature

Measurement range -10 ... +60 °C (+14 ... +140 °F)

Accuracy at +20 °C (+68 °F) ±0.2 °C (±0.36 °F)

Typical temperature dependence of electronics ±0.005 °C/°C (±0.005 °F/°F)

Temperature sensor Pt100 RTD Class F0.1 IEC 60751

Other Variables Available

Dew point converted to atmospheric pressure, ppm volume and ppm weight concentration, absolute humidity, mixing ratio, relative humidity

Operating Environment, All Probe Models

Operating temperature -10 ... +60 °C (+14 ... +140 °F)

Operating pressure for DMP74A, DMP74B 0 ... 20 bara (0 ... 290 psia)

Operating pressure for DMP74C 0 ... 10 bara (0 ... 150 psia)

Sample flow rate No effect for measurement accuracy

Measured gases Non-corrosive gases

EMC compliance EN61326-1, Generic Environment

Mechanical Specifications

Probe material (wetted parts) Stainless steel (AISI 316L)

Sensor protection Sintered filter (AISI 316L)

Mechanical connection G1/2" ISO228-1 thread with bonded seal ring (U-seal)

IP rating IP65 (NEMA 4)

Weight 350 g

Measurement Performance, DMP74B and DMP74C (for SF6 gas) Probes

Dew Point

Measurement range (typical) -70 ... +30 °C (-94 ... +86 °F)

Dew Point Accuracy vs. Measurement Conditions

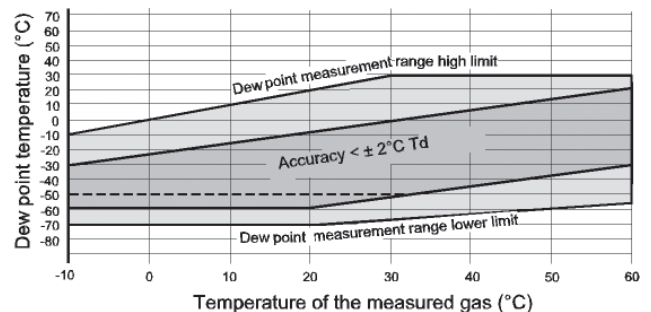

Dotted line:

For DMP74C the ±2 °C accuracy range is limited to -50 °C T_d when used in SF6 gas.

Accuracy (B and C probe) -60 ... +20 °C ±2 °C (±3.6 °F)
(see graph)

Response Time

Flow rate 0.2 m/s, 1 bar pressure, +20 °C (+68 °F) 63% [90%]

0 → -60 °C T_d (32 → -76 °F T_d) 50 s [340 s]

-60 → 0 °C T_d (-76 → 32 °F T_d) 10 s [20 s]

Dew point sensor Vaisala DRYCAP® 180M

Temperature

Measurement range -10 ... +60 °C (+14 ... +140 °F)

Accuracy at +20 °C (+68 °F) ±0.2 °C (±0.36 °F)

Typical temperature dependence of electronics ±0.005 °C/°C (±0.005 °F/°F)

Temperature sensor Pt100 RTD Class F0.1 IEC 60751

Other Variables Available

Dew point converted to atmospheric pressure, ppm volume and ppm weight concentration

MI70 Measurement Indicator

Operating Environment

Operating temperature	-10 ... +40 °C (+14 ... +104 °F)
Operating humidity	0 ... 100 %RH, non-condensing
Storage temperature	-40 ... +70 °C (-40 ... +158 °F)

Inputs and Outputs

Max. no of probes	2
Power supply	Rechargeable NiMH battery pack with AC adapter or 4xAA size alkalines, type IEC LR6
PC interface	MI70 Link software with USB or serial port cable

Analog Output

Scale	0...1 VDC
Output resolution	0.6 mV
Accuracy	0.2 % full scale
Temperature dependence	0.002 %/°C (0.01 %/°F) full scale
Minimum load resistor	10 kΩ to ground

Mechanical Specifications

Housing classification	IP54
Housing materials	ABS/PC blend
Weight	400 g (14 oz)

Compatibility

EMC compliance	EN61326-1, Portable Equipment
----------------	-------------------------------

Other

Menu languages	English, Chinese, Spanish, Russian, French, Japanese, German, Swedish, Finnish
----------------	--

Display	<ul style="list-style-type: none"> LCD with backlight Graphic trend display of any parameter Character height up to 16 mm (0.63 in)
---------	--

Alarm	Audible alarm function
Data logging capacity	2700 real time data points
Logging interval	1 s to 12 h
Logging duration	1 min ... memory full
Resolution	0.01 %RH, 0.01 °C/°F, 0.01 hPa, 0.01 a _w , 10 ppm / 0.01 %CO ₂

Spare Parts and Accessories

Weatherproof Carrying Case	MI70CASE3
Soft Carrying Case	MI70SOFTCASE
MI70 Link software with USB cable	219687
MI70 Link software with serial port cable	MI70LINK
Analog output cable	27168ZZ
10 m (32.81 ft) extension cable for probe	213107SP
Portable Sampling System (see separate data sheet)	DSS70A

Connection Cables for Fixed Vaisala Dew Point Transmitters

For DMT242 transmitter	27160ZZ
For DMT340 series	211339
For DMT152, DMT143, and DMT132 transmitters	219980SP

Battery Operation Time

Typical charging time 4 hours

Operation Times

Continuous use	48 h typical at +20 °C (68 °F)
Data logging use	Up to a month



MI70 dimensions in millimeters (inches)

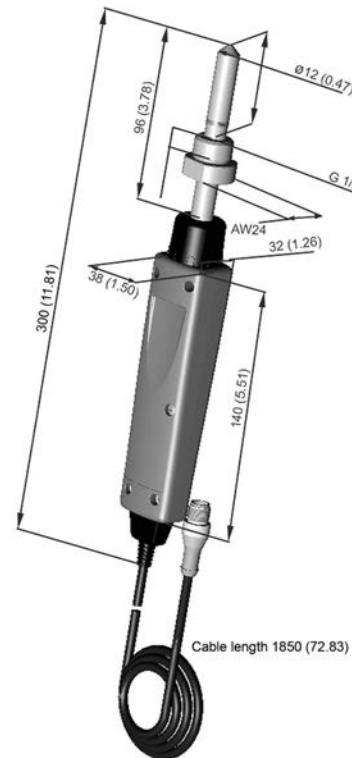

Probe dimensions in millimeters (inches)



Features

- Battery-powered pump for extracting gas samples
- Five sampling cell options for gas sampling
- Filter for removing particulate contamination before measurement
- Needle valve and flow meter for controlling and monitoring flow through the system
- Connectable to pressurized processes

DSS70A provides a compact solution for field checking dew point where direct measurement is difficult. Typical applications for the sampling system are metal treatment and plastics drying processes.

DSS70A Portable Sampling System

DSS70A is designed to provide dew point sampling flexibility for the DM70 hand-held dew point meter. For processes at atmospheric pressure, a battery powered pump is used to extract a gas sample. For pressurized processes up to 20 bar, the sample is measured at process pressure and then reduced to atmospheric pressure for venting or re-direction, bypassing the pump. In all cases, the sample gas passes through a filter to remove particulate contamination before measurement. Flow through the system is controlled and monitored with a needle valve and flow meter. DSS70A is easily connected to an appropriate sample point with tubing (typically 1/4" or 6 mm). The measured dew point must be below ambient temperature to avoid condensation in the system. Gas temperatures higher

than +40 °C (+104 °F) should be cooled with a short PTFE (included in the DSS70A system) or stainless steel tube prior to entering DSS70A. DSS70A is an accessory for DM70 Dewpoint Handheld Meter.

Sampling Cells for Pressurized Processes

DM70 can easily be connected to pressurized processes. In addition to direct pipeline installation, a variety of sampling cell options are available for gas sampling.

DSC74 sampling cell is the recommended choice. It has a variety of connection adapters that allow several different ways of installation. The quick connector with a leak screw allows a very fast connection for compressed air lines. Additionally, two thread adapters are available for the inlet port.

DSC74B is a two-pressure sampling cell, which enables measurements in both process and ambient pressure. This sampling cell is especially suitable for dew point measurements in SF6 gas with the DMP74C probe.

DMT242SC is a basic sampling cell. DMT242SC2 is a sampling cell supplied with welded Swagelok connectors for sampling in a 1/4" pipeline.



The sampling cells (from the left) DMT242SC2, DMT242SC and DSC74 can be used to connect the DM70 to sample gas flow. The DSC74B (right) is a two-pressure sampling cell that can be used for measurements in either pressurized or ambient pressure. The cooling/venting coil is included in the DSC74C sample cell, but is an option for all sampling cells.

Technical Data

DSS70A Sampling System and DSC74B/C Sampling Cells

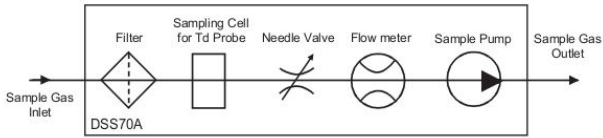

The DSS70A sampling system includes a filter to clean the dirty sample gas and a needle valve to control the sample flow rate with the flow meter. A sample pump is used to generate a sample flow from processes at ambient pressure.

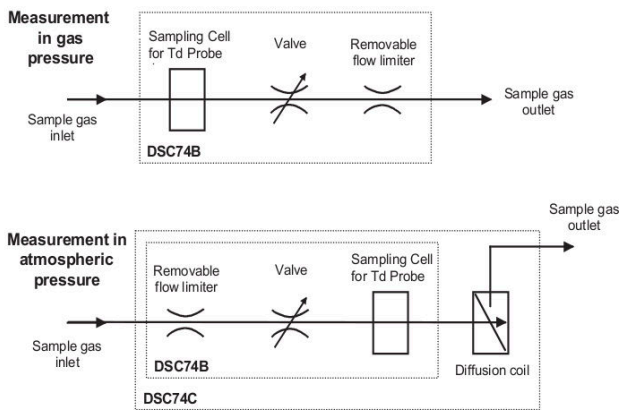

The DSC74B sampling cell enables the measurement of the sampled gas either in gas pressure up to 10 bar or in atmospheric pressure depending on the gas inlet and outlet. DSC74C is like DSC74B but with an additional coil to avoid back diffusion, the effect of surrounding moisture, in dew point measurements in atmospheric pressure.

DSS70A Operating Environment

Operating gases	Air, N ₂ , and other non-toxic, inert gases
Sampled gas dew point	Below Tamb
Inlet/outlet connection	1/4" Swagelok
Operating ambient temperature	0 ... +40 °C (+32 ... +104 °F)
Operating process gas temperature with PTFE tube at +20 °C (+68 °F) (included in the DSS70A)	Max. +200 °C (+392 °F)
Operating temperature with stainless steel tube	Specification according to stainless steel tube specification
Maximum gas temperature at inlet	+40 °C (+104 °F)
Operating pressure with pump	0.6 ... 1.2 bara (8.7 ... 17.4 psia)
Operating pressure with pump disconnected	0 ... 20 bara (0 ... 290 psia)

Mechanical Specifications

Battery operation time for pump	8 h continuous use (battery can be recharged using DM70 charger)
Filter	7 mm inline filter cartridge 1/4" Swagelok SS-4F-7 (spare part order no. 210801)
Case dimensions (W × D × H)	430 × 330 × 100 mm
Weight	5.5 kg (12 lbs)
Materials	
Wetted parts	Stainless steel
Carrying case	ABS plastic

Sampling Cell Options

DSC74	Sampling cell for pressurized gases
DSC74 pressure limit	1 MPa (10 barg, 145 psig)
DSC74B	Two pressure sampling cell
DSC74B pressure limit	1 MPa (10 barg, 145 psig)
DSC74C	DSC74B with DMCOIL cooling/venting coil
DMCOIL	Cooling/venting coil
DMT242SC	Sampling cell
DMT242SC pressure limit	10 MPa (100 barg, 1450 psig)
DMT242SC2	Sampling cell with Swagelok connectors
DMT242SC2 pressure limit	4 MPa (40 barg, 580 psig)
Material for all sampling cells	Stainless steel AISI316

Compliance

EMC	EN61326-1, Generic Environment
-----	--------------------------------

VAISALA

www.vaisala.com



DPT146 Dew Point and Pressure Transmitter

For Compressed Air



Features

- The first transmitter that monitors both dew point and process pressure
- A simple and convenient transmitter for monitoring of compressed air
- Highly accurate humidity information thanks to dew point data coupled with live pressure input
- Proven sensor technology
- Compatible with Vaisala Hand-Held Meter DM70 for easy spot checking, local display and data logging

Vaisala Dewpoint and Pressure Transmitter DPT146 for Compressed Air makes monitoring compressed air simple and convenient. DPT146 measures both dew point and process pressure simultaneously, and is the ideal choice for anyone using or monitoring compressed air.

Simple and Efficient Installation

One transmitter providing two of the most important compressed air measurements means reduced installation costs and a much easier setup – with only one instrument needing connection and wiring.

Make More Informed Decisions

Dew point measurement combined with process pressure measurement offers further unique advantages. When dew point data is coupled with live pressure input, conversions to atmospheric pressure or ppm are available online, leaving no ambiguity in the information. As an example, regulative requirements of medical gas can be fulfilled easily and quickly.

A Unique Combination of Two World-Class Sensors

DPT146 combines the knowledge of more than 20 years of sensor technology development. Proven measurements from DRYCAP® sensor for dew point and BAROCAP® sensor for pressure are now combined into one easy-to-use transmitter.

Convenience with Proven Performance

Well-developed technology brings both proven results and convenience. Spot-checking and verification of dew point is easy thanks to fully compatible Vaisala DRYCAP® Hand-Held Dewpoint Meter

DM70. The meter can also be used as a local display and data logger. Temperature measurement is available when RS-485 is in use.

Output and Performance

- Pressure: 1 ... 12 bar
- Dew point: -70 ... +30 °C (-94 ... +86 °F)
- Digital output RS-485 with Modbus

Technical Data

Parameters

Measured Parameters

Dew point	-70 ... +30 °C (-94 ... +86 °F)
Pressure, absolute	1 ... 12 bar (14.5 ... 174 psi)
Temperature (available if output RS-485 only selected)	-40 ... +80 °C (-40 ... +176 °F)

Calculated Parameters

ppm moisture, by volume	1 ... 40 000 ppm
Dew point, converted to atmospheric pressure	-75 ... +30 °C (-103 ... +86 °F)

Measurement Performance

Sensor	Vaisala MPS1 multiparameter sensor
Dew point accuracy	±2 °C (±3.6 °F)
Pressure accuracy at 23 °C (73.4 °F)	±0.4 %FS
Pressure temperature dependence	±0.01 bar / 10 °C (18 °F)
ppm accuracy (7 bar)	±(14 ppm + 12 % of reading)
Temperature Accuracy	
0 ... 40 °C (+32 ... +104 °F)	±0.5 °C (±0.9 °F)
-40 ... 80 °C (-40 ... +176 °F)	±1 °C (±1.8 °F)
Sensor Response Time	
Pressure response time	< 1 s
Dew point response time 63 % [90 %] at 20 °C and 1 bar:	
-50 → -10 °C Tdf	5 s [10 s]
-10 → -50 °C Tdf	10 s [2.5 min]

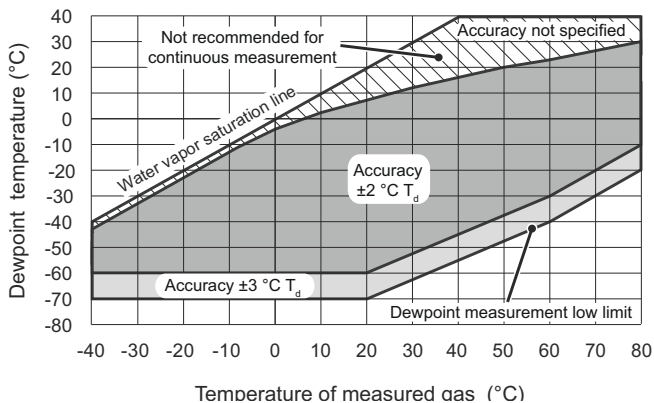

Operating Environment

Operating temperature of electronics	-40 ... +60 °C (-40 ... +140 °F)
Operating pressure	0 ... 50 bar (0 ... 725 psi)
Relative humidity	0 ... 100 %
Measured gases	Air/non-corrosive gases
Sample flow rate	No effect on measurement accuracy
Storage Temperature	
Transmitter only	-40 ... +80 °C (-40 ... +176 °F)
Shipment package	-20 ... +80 °C (-4 ... +176 °F)

Compliance

IP rating	IP66
Electromagnetic compatibility	EMC standard EN61326-1, Electrical equipment for measurement, control and laboratory use - EMC requirements; Industrial environment

Inputs and Outputs

Accuracy of analog outputs	±0.01 V / ±0.01 mA
Digital output	RS-485, non-isolated, Vaisala protocol, Modbus RTU protocol
Connector	4-pin M8

Operating Voltage

Current output	21 ... 28 VDC
Voltage output and/or use in cold temperatures (-40 ... -20 °C (-40 ... -4 °F))	20 ... 28 VDC
RS-485 only	15 ... 28 VDC

Analog Outputs (2 Channels)

Current output	0 ... 20 mA, 4 ... 20 mA
Voltage output	0 ... 5 V, 0 ... 10 V

Supply Current

During normal measurement	20 mA + load current
During self-diagnostics	300 mA + load current

External Load for

Current output	Max. 500 Ω
Voltage output	Min. 10 kΩ

Mechanical Specifications

Housing material	AISI316L
Mechanical connection	ISO G1/2 in, NPT 1/2 in, UNF 3/4 in-16
Recommended calibration interval	2 years
Sensor protection	Mesh filter AISI303, grade 18 μm
Weight (ISO1/2")	190 g (6.70 oz)

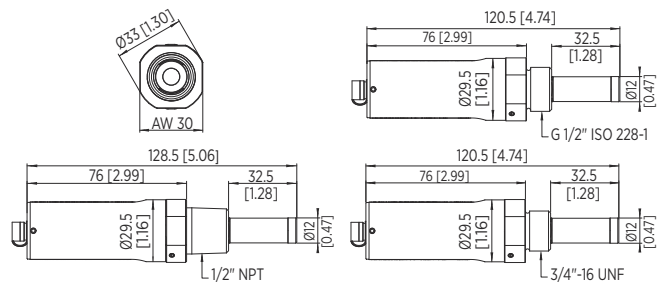

Dimensions in mm (inches)

Spare Parts and Accessories

Connection cable for MI70 indicator / DM70 meter	219980
USB connection cable	219690
Sampling cells	DMT242SC, DMT242SC2, DSC74, DSC74B, DSC74C
Flange	DM240FA
Loop-powered external display	226476
ISO1/2 in plug	218773
NPT 1/2 in plug	222507

VAISALA

www.vaisala.com



Features

- First transmitter to offer online measurement of seven SF6 parameters in one unit
- Measured parameters: dew point, pressure, temperature
- Calculated parameters: SF6 density, normalized pressure, dew point in atmospheric pressure, ppm
- More reliable assessment of the condition of SF6 insulation due to online measurement
- Digital output: RS-485 with Modbus®
- Long calibration interval of years

The Vaisala Multiparameter Transmitter DPT145 with the DILO DN20 connector

Vaisala Multiparameter Transmitter DPT145 for SF6 Gas is a unique innovation that enables online measurement of dew point, pressure, and temperature. It also calculates four other values, including SF6 density. DPT145 is especially well suited for integration into OEM systems.

Online Reliability

Online dew point measurement combined with pressure measurement provides an excellent assessment of the condition of the SF6 insulation. Sudden and minor leakages are immediately detected by the direct normalized pressure measurement, while online dew point measurement alerts the user to moisture issues, which can weaken the insulation properties of SF6 and cause rapid deterioration. With the DPT145, it is also easy to build a redundant solution for multiple parameters.

Savings Across the Board

A single transmitter, instead of several, saves time and money across the board, from investment to installation, operation, and servicing. Lower assembly

costs, fewer cables and connectors, minimized need for on-site visits and field operations - all these translate into cumulative savings. The long calibration interval results in further savings.

Risk-free, Greener Solution

Online measurement enables gas trends to be followed via a data collection system, making monitoring fast, risk-free, and accurate. Using one instrument for monitoring seven different parameters means also fewer mechanical connections and reduces the risk of leaks. Monitoring is environmentally friendly because there is no need for sampling - no SF6 gas is released into the atmosphere.



The DPT145 with the weather shield

The Fruit of Experience

Vaisala has over 70 years of extensive measurement experience and knowledge. DPT145 brings together the proven DRYCAP® dew point sensor technology and BAROCAP® pressure sensor technology in one package, providing an innovative and convenient solution for monitoring SF6 gas.

Technical Data

Measured Parameters

Dew point	-50 ... +30 °C (-58 ... +86 °F)
Pressure, absolute	1 ... 12 bar (14.5 ... 174 psi)
Temperature	-40 ... +80 °C (-40 ... +176 °F)

Calculated Parameters

Pressure, normalized to +20 °C (+68 °F)	1 ... 12 bar (14.5 ... 174 psi)
SF6 or SF6/N2 mixture density	0 ... 100 kg/m ³
Moisture by volume, ppm	40 ... 40 000 ppm
Dew point, converted to atmospheric pressure	-65 ... +30 °C (-85 ... +86 °F)

Measurement Performance

Dew point accuracy	±3 °C (±5.4 °F), see graph below
Dew point stability	Typical drift < 2 °C (3.6 °F) / 5 years
Pressure accuracy at +23 °C (+73.4 °F)	±0.4 %FS
Pressure temperature dependence	±0.01 bar/10 °C (18 °F)
Pressure stability	Typical drift < 1 %FS / 5 years
Temperature accuracy	0 ... +40 °C (+32 ... +104 °F): ±0.5 °C (± 0.9 °F) -40 ... 80 °C (-40 ... +176 °F): ±1 °C (± 1.8 °F)
Density accuracy (pure SF6, 1 ... 12 bara)	0 ... +40 °C (+32 ... +104 °F): ±1 %FS -40 ... +60 °C (-40 ... +140 °F): ±2.2 %FS
Typical ppm accuracy (5 ... 1000 ppm, 7 bar)	±(7 ppm + 15 % of reading)
Sensor	Vaisala MPS1 multiparameter sensor

Sensor Response Time

Pressure response time	< 1 s
Dew point response time ¹⁾	-50 → -10 °C Tdf: 5 s [10 s] 63 % [90 %] at 20 °C and 1 bar
	-10 → -50 °C Tdf: 10 s [2.5 min]

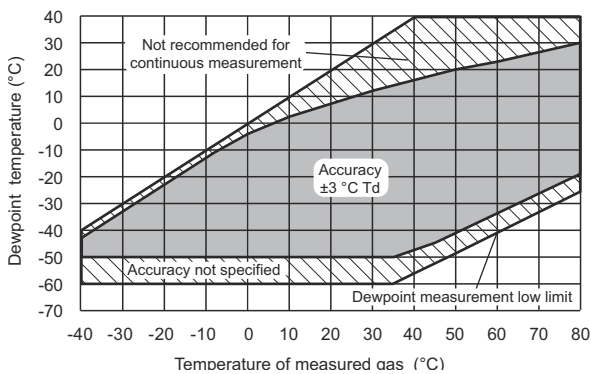

DPT145 dew point measurement accuracy

¹⁾ System equilibrium related response time is typically longer.

Inputs and Outputs

Digital inputs	RS-485, non-isolated, Vaisala protocol Modbus® RTU protocol
Connector	4-pin M8
Operating voltage	15 ... 28 VDC 20 ... 28 VDC in cold temperatures (-40 ... -20 °C (-40 ... -4 °F))
Supply current, during normal measurement	20 mA
Supply current, during self-diagnostics	Max. 300 mA pulsed

Operating Environment

Operating temperature of electronics	-40 ... +60 °C (-40 ... +140 °F)
Operating pressure	0 ... 50 bar (0 ... 725 psi)
Relative humidity	0 ... 100 %
Measured gases	SF ₆ , SF ₆ /N ₂ mixture
Storage temperature, transmitter only	-40 ... +80 °C (-40 ... +176 °F)
Storage temperature, shipment package	-20 ... +80 °C (-4 ... +176 °F)

Mechanical Specifications

Housing material	AISI316L
Weather shield to be used for continuous outdoor installations	
Mechanical connection	DILO DN20, DILO DN8, ABB Malmkvist, or Alstom G1/2 in compatible connector Every connection is helium leak tested at the factory.
Weight (with DILO adapter)	765 g (27.0 oz)

Compliance

IP rating	IP66
EMC compliance	EN61326-1, Electrical equipment for measurement, control and laboratory use - EMC requirements

Industrial Environment, Tested Levels

EN/IEC 61000-4-2, Electrostatic Discharge	8 kV con / 15 kV air
EN/IEC 61000-4-3, RF field immunity	10 V/m (80MHz-4.2GHz)
EN/IEC 61000-4-4, Electric Fast Transient	±2 kV power and signal
EN/IEC 61000-4-5, Surge	±2 kV power line to ground / ±1kV signal line to ground and power line to line
EN/IEC 61000-4-6, Conducted RF Immunity	10 Vemf power line and digital output
Mechanical Vibration	
EN/IEC 60068-2-6, Fc Sinusoidal vibration	±6 g, 5-500 Hz sweep 60 min/axis, 3-axis

Spare Parts and Accessories

Connection cable for the MI70/DM70 hand-held	219980
USB connection cable	219690
Protection plug for connector	218675SP
1.5 m shielded PUR cable with 90° connector	231519SP
3 m shielded PUR cable with 90° connector	231520SP
5 m shielded PUR cable with 90° connector	231521SP
10 m shielded PUR cable with 90° connector	231522SP
3.0 m shielded FEP cable with straight connector	226902SP
Weather shield	ASM210326SP

Technical Data

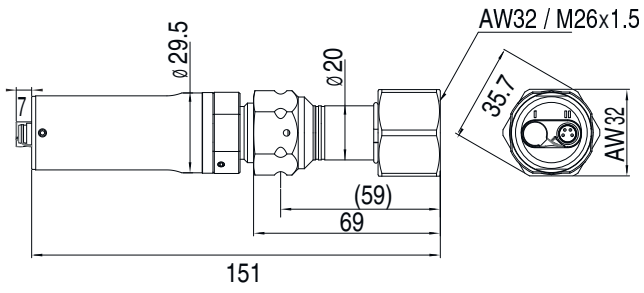

DPT145 with DILO DN8 connector

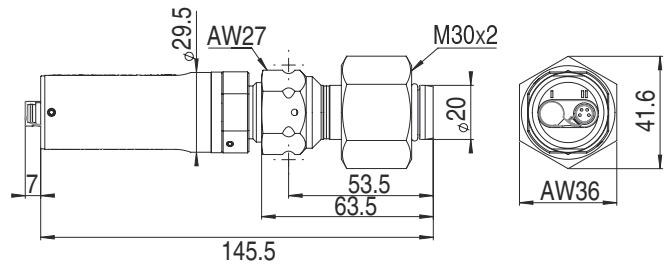

DPT145 with the ABB Malmkvist connector

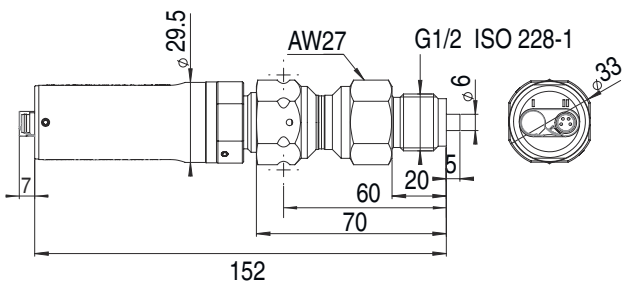

DPT145 with the Alstom connector

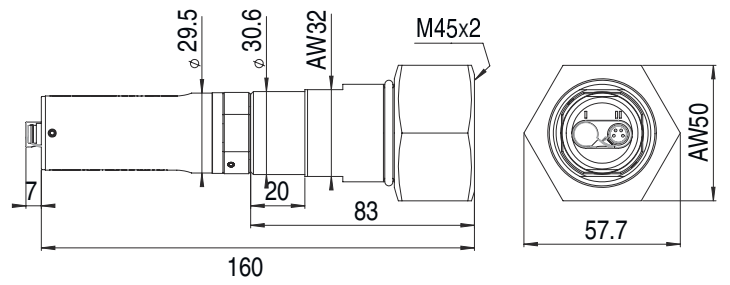

DPT145 with the DILO DN20 connector

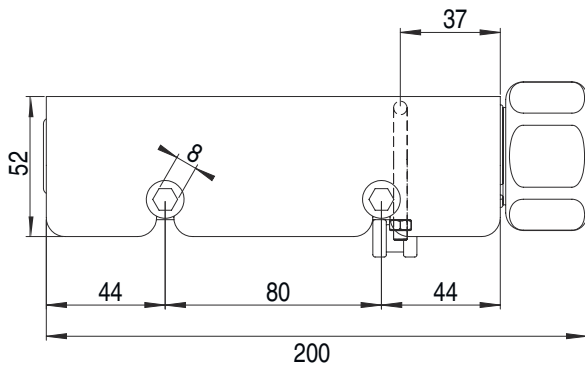

DPT145 with the weather shield

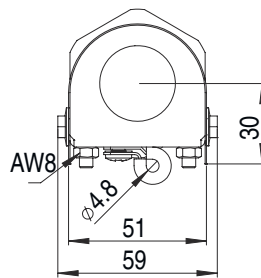



Features

- Vaisala CARBOCAP® Sensor, a silicon-based non-dispersive infrared (NDIR) sensor
- Single-beam, dual wavelength CO₂ measurement with no moving parts
- Compensation options for temperature, pressure, humidity and oxygen
- Designed for outdoor use

Vaisala CARBOCAP® Carbon Dioxide Probe GMP343 is an accurate and rugged probe-type instrument for ecological measurements. Typical applications include CO₂ soil respiration, ambient CO₂ monitoring, plant growth chambers, and OEM applications.

Benefits

- Low power consumption and heat emission
- Compact and lightweight
- Excellent accuracy and stability

GMP343 can output both numerically filtered and raw measurement data and it can also compensate the measurement with an internal temperature measurement and user-set relative humidity, pressure and oxygen values.

In combination with an MI70 indicator, GMP343 provides a tool for accurate in-situ measurement. MI70 can be used as a display, communication and data logging device.

Each GMP343 is calibrated using $\pm 0.5\%$ accurate gases at 0 ppm, 200 ppm, 370 ppm, 600 ppm, 1000 ppm, 4000 ppm and 2%. Calibration is also done at temperature points of -30 °C, 0 °C, 25 °C and 50 °C. If needed, the

customer can recalibrate the instrument using the multipoint calibration (MPC) feature allowing up to 8 user-defined calibration points.

Technical Data

Measurement Performance

Measurement range options	0 ... 1000 ppm, 0 ... 2000 ppm, 0 ... 3000 ppm, 0 ... 4000 ppm, 0 ... 5000 ppm, 0 ... 2 %
---------------------------	---

Accuracy (Excluding Noise) at 25 °C (77 °F) and 1013 hPa after Factory Calibration with 0.5 % Accurate Gases with Different Range Options

0 ... 1000 ppm	±(3 ppm + 1 % of reading)
0 ... 2000 ppm - 0 ... 2 % ¹⁾	±(5 ppm + 2 % of reading)

Noise (Repeatability) at 370 ppmCO₂

With no output averaging	±3 ppmCO ₂
With 30 s output averaging	±1 ppmCO ₂

Long-term Stability (See Graph 'GMP343 Operating Conditions')

Easy	±2 % of reading ^{2)/} year
Moderate	±2 % of reading ^{2)/} 6 months
Harsh	±2 % of reading ^{2)/} 3 months

Warm-up Time

To full accuracy ±0.5 %	10 min
To full accuracy	30 min

- 1) Accuracy below 200 ppmCO₂ not specified for 2 % range option
2) Always at least ±10 ppmCO₂.

Effect on Accuracy with Temperature Compensation

CO ₂ range options	0 ... 1000 ppm	0 ... 2 000 - 5000 ppm	0 ... 2 %
-------------------------------	----------------	------------------------	-----------

Temperature °C (°F)	Accuracy (% of reading) ¹⁾		
+10 ... +40 (+50 ... +104)	±1	±1	±2
+40 ... +60 (+104 ... +140)	±2	±3	±4
-40 ... +10 (-40 ... +50)	±3	±3	±5

- 1) Always at least ±10 ppmCO₂.
Temperature compensation is performed by an integrated Pt1000 element.

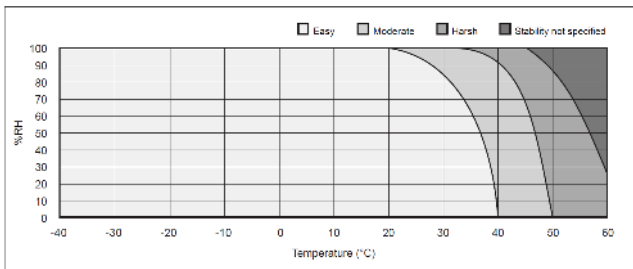

GMP343 Operating Conditions

Effect on Accuracy with Pressure Compensation

CO ₂ range options	0 ... 1000 ppm	0 ... 2000 - 2 %
-------------------------------	----------------	------------------

Pressure (hPa)	Accuracy (% of reading)	
900 ... 1050	±0.5	±1
700 ... 1300	±1	±2

Integrated pressure sensor **not** included in GMP343.

Response Time (90%)

Diffusion Model

Filter attached	Averaging (s)	Response (s)
Yes	0	75
Yes	30	82
No	0	<2
No	30	30

Flow-through Model

Gas flow (l/min)	Averaging (s)	Response (s)
0.3	0	26
0.3	30	44
1.2	0	8
1.2	30	23

Operating Environment

Operating temperature	-40 ... +60 °C (-40 ... +140 °F)
Storage temperature	-40 ... +70 °C (-40 ... 158 °F)
Operating humidity	See graph 'GMP343 Operating Conditions'
Compensated pressure range	700 ... 1300 hPa
Operating pressure	< 5 bar
Gas flow for flow-through model	0 ... 10 liters/min
EMC compliance	EN61326, Generic Environment

Inputs and Outputs

Operating voltage	11 ... 36 VDC
Power consumption	Without optics heating : < 1 W With optics heating : < 3.5 W
Digital outputs	RS-485, RS-232

Analog Outputs

Current output range	4 ... 20 mA
Current output resolution	14 bits
Current output maximum load	800 Ω at 24 VDC, 150 Ω at 10 VDC
Voltage output range	0 ... 2.5 V, 0 ... 5 V
Voltage output resolution	14 bits (13 bits with 0 ... 2.5 V)
Voltage output minimum load	5 kΩ

Mechanical Specifications

Housing	Anodized aluminium
Filter cover	PC
Cable connector type	8-pin M12
Weight (probe only)	360 g

IP Rating

Housing (cable attached)	IP67
Diffusion filter (weather protection)	IP65
Diffusion filter (sintered PTFE)	IP66

Spare Parts and Accessories

Wall mount bracket	GMP343BRACKET
Mounting flange	GMP343FLANGE
Standard diffusion filter (weather protection, IP65) with filter cover	GMP343FILTER
Diffusion filter (sintered PTFE filter, IP66) with filter cover	215521
Calibration adapter (for the diffusion model)	GMP343ADAPTER
Junction box	JUNCTIONBOX-8
Probe cables	
PC connection cable, 2 m (6 ft 7 in)	213379
MI70 connection cable, 2 m (6 ft 7 in)	DRW216050SP
USB adapter (USB-D9 Serial connection cable)	219686
Soil adapter kit for horizontal positioning	215519
Soil adapter kit for vertical positioning	215520
Cable Options	
2 m (6 ft 7 in)	GMP343Z200SP
6 m (19 ft 8 in)	GMP343Z600SP
10 m (32 ft 10 in)	GMP343Z1000SP



Features

- Probe durable during heat sterilization up to +180 °C (+356 °F)
- Incubator can be sterilized with probe in place, saving time and reducing risk of cross-contamination
- Heat durability and superior long-term stability with next generation CARBOCAP® sensor
- Designed for OEM use in CO₂ incubators – installation options available
- CO₂ sensor measurement optimized for 5 % CO₂, measurement range up to 20 % CO₂
- 4-point traceable calibration for CO₂

Vaisala CARBOCAP® Carbon Dioxide Probe GMP231 withstands high temperature sterilization.

GMP231 is designed to provide incubator manufacturers with accurate and reliable carbon dioxide measurements and sterilization durability at high temperatures. The probe is based on Vaisala's patented CARBOCAP® technology and a new type of infrared (IR) light source. These technologies allow for sterilization temperatures of up to 180 °C (+356 °F), enabling easier and more complete sterilization without the risk of cross-contamination.

The probe is installed through the incubator wall, ensuring that only the IR sensor and optical components are exposed to the incubation

environment. This allows the incubator to be sterilized with the probe in place, removing the need to decontaminate the probe separately. This saves time and reduces the risk of contamination.

The probe's sensor performance is optimized at 5 %CO₂, but the sensor measures CO₂ up to 20 % with high accuracy. In addition, GMP231 can measure pressure and temperature for CO₂ measurement compensation purposes, ensuring the product remains stable and accurate in all CO₂ incubation conditions. The sensor is made of highly durable materials to achieve outstanding stability over both time and temperature.

Since water vapor, dust, and most chemicals do not affect measurements, GMP231 module is ideal for CO₂ incubator environments.

Benefits

- Internal pressure and temperature measurement improves accuracy and stability
- Full temperature and pressure compensations available
- Sensor head heating for condensation prevention

Technical Data

Measurement Performance

Measurement range	0 ... 20 %CO ₂
Calibration uncertainty at 5 %CO ₂	±0.1 %CO ₂
Start-up time	< 20 s
Warm-up time for full spec.	< 3 min
Response Time	
T63	< 30 s
T90	< 50 s
Accuracy at 37 °C, 1013 hPa	
Repeatability at:	
0 ... 8 %CO ₂	±0.1 %CO ₂
8 ... 12 %CO ₂	±0.2 %CO ₂
12 ... 20 %CO ₂	±0.4 %CO ₂
Non-linearity at 0 ... 20 %CO ₂	±0.1 %CO ₂
Temperature Dependence	
With compensation at 3 ... 12 %CO ₂ , 20 ... 60 °C	±0.1 %CO ₂
Without compensation (typical)	-0.4 % of reading/°C
Pressure Dependence	
With compensation at 3 ... 12 %CO ₂ , 700 ... 1100 hPa	±0.015 % of reading/hPa
Without compensation (typical)	+0.15 % of reading/hPa
Humidity Dependence	
With compensation at 0 ... 20 %CO ₂ , 0 ... 100 %RH	±0.9 % of reading (at 37 °C)
Without compensation (typical)	+0.05 % of reading/%RH
O₂ dependence	
With compensation at 0 ... 20 %CO ₂ , 0 ... 90 %O ₂	±0.6 % of reading
Without compensation (typical)	-0.08 % of reading/%O ₂
Long-term Stability	
0 ... 8 %CO ₂	< ±0.2 %CO ₂ /year
8 % ... 12 %CO ₂	< ±0.5 %CO ₂ /year
12 % ... 20 %CO ₂	< ±1.0 %CO ₂ /year

Mechanical Specifications

Connector	M12/8 pin
Weight	150 g (5.29 oz) without cable
IP rating	IP54 (sensor head) IP20 (electronics housing)
Materials	
Housing	Metal coated plastic ABS+PC
Inner tube	Aluminum
Probe tube	PPSU
Filter	PTFE
Dimensions	
Probe tube max. diameter	30.2 mm (1.19 in)
Probe tube length	118.5 mm (4.67 in)
Sensor filter length	12 mm (0.47 in)

Operating Environment

Operating temperature for CO ₂ measurement	0 ... +70 °C (+32 ... +158 °C)
Max. temperature durability in standby mode (sensor head only)	Max. +195 °C (Max. +383 °C)
Heat sterilization 180 °C durability	At least 120 cycles
Storage temperature	-40 ... +75 °C (-40 ... +167 °C)
Pressure (compensated)	500 ... 1100 hPa
Pressure (operating)	< 1500 hPa
Humidity	0 ... 100 %, non-condensing
Condensation prevention	Sensor head heating when power on
Chemical tolerance	DMSO, IPA (70 %), H ₂ O ₂ (2000 ppm, non-condensing), ethanol, acetic acid
Electromagnetic compatibility	EN61326-1, Generic Environment

Inputs and Outputs

Digital outputs	I ² C 5 V, RS-485 (2-wire with Vaisala industrial protocol)
Analog output	0 ... 20 mA (scalable) max. load 600 Ω
Power consumption	< 1 W (pulsed)
Operating voltage	11 ... 30 VDC 20 ... 30 VDC (with analog output)

Accessories

M12 Connection Cable 0.9 m with open ends	DRW240977SP
M12 Connection Cable 0.6 m with Milli-Grid connector	ASM210903SP
Service cable for MI70	221801
Silicone plug	DRW240015SP
Attachment bracket	DRW240247SP
PTFE filter	DRW240494SP
USB PC connection cable	DRW240494SP
Calibration adapter for GMP231	239523

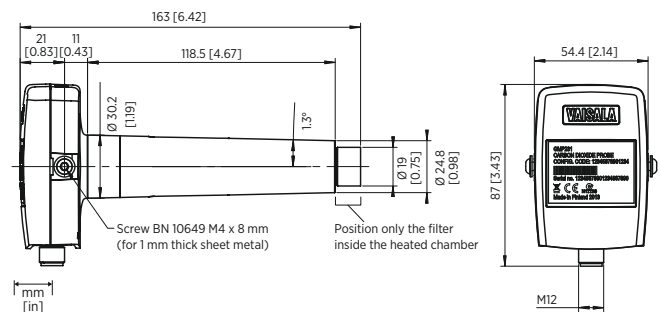

Dimensions

VAISALA

www.vaisala.com



Features

- Measurement range 0 ... 20 %CO₂
- Intelligent, stand-alone probe with analog and digital outputs
- Compatible with Indigo 200 transmitters and Vaisala Insight
- Wide operating temperature range -40 ... +60 °C
- IP65-classified housing
- Full temperature and pressure compensations
- 2nd-gen proprietary CARBOCAP® technology
- Integrated temperature measurement for CO₂ compensation purposes
- Compensations for background gases, O₂, and humidity
- Sensor head heated to prevent condensation

Vaisala CARBOCAP® Carbon Dioxide Probe GMP251 is a new intelligent probe for measuring carbon dioxide. This robust, stand-alone measurement device is designed for use in demanding applications, such as life science incubators, where stable, reliable, and accurate performance is required.

Benefits

- Superior long-term stability
- Reliable and accurate
- Calibration certificate included

GMP251 is based on Vaisala's unique, second-generation CARBOCAP technology that enables exceptional stability. A new type of infrared (IR) light source is used instead of the traditional incandescent light bulb, which extends the lifetime of GMP251.

GMP251 incorporates an internal temperature sensor for compensation of the CO₂ measurement according to ambient temperature. The effects of pressure and background gas can also be compensated for. The measurement range is 0 ... 20 %CO₂ and the sensor performance is optimized at 5 %CO₂ measurement.

The operating temperature range of the probe is wide (-40 ... +60 °C (-40 ... +140 °F)), and the probe housing is classified as IP65. Condensation is prevented as the internal sensor head is heated.

GMP251 is resistant to dust and most chemicals, such as, H₂O₂ and alcohol-based cleaning agents.

Ease of Use

GMP251 is a compact probe with easy and fast plug-in, plug-out installation. The surface of the probe is smooth, which makes it easy to clean. The probe provides several output options, including analog current and voltage outputs and digital RS-485 output with Modbus protocol.

GMP251 can be connected to Indigo 200 series transmitters for an extended range of output and configuration options. See www.vaisala.com/indigo.

For easy-to-use access to field calibration, device analytics, and configuration functionality, the probe can be connected to Vaisala Insight PC Software (for Windows® 7, 8.1 and 10: see www.vaisala.com/insight).

Applications

GMP251 is ideal for life science incubators, cold storages, fruit and vegetable transportation, and for all demanding applications where stable and accurate %-level CO₂ measurements are needed.

Technical Data

Measurement Performance

Measurement range	0 ... 20 %CO ₂
Accuracy at 25 °C (77 °F) and 1013 hPa (incl. Repeatability and Non-linearity)	
At 5 %CO ₂	±0.1 %CO ₂
0 ... 8 %CO ₂	±0.2 %CO ₂
8 ... 20 %CO ₂	±0.4 %CO ₂
Calibration Uncertainty	
At 5 %CO ₂	±0.12 %CO ₂
At 20 %CO ₂	±0.32 %CO ₂
Long-Term Stability	
0 ... 8 %CO ₂	±0.3 %CO ₂ /year
8 ... 12 %CO ₂	±0.5 %CO ₂ /year
12 ... 20 %CO ₂	±1.0 %CO ₂ /year
Temperature Dependence	
With compensation at 5 %CO ₂ , 0 ... +50 °C (+32 ... +122 °F)	< ±0.05 %CO ₂
With compensation, 0 ... 20 %CO ₂ , -40 ... +60 °C (-40 ... +140 °F)	±0.045 % of reading/°C
Without temperature compensation at 5 %CO ₂ (typical)	-0.25 % of reading/°C
Pressure Dependence	
With compensation at 5 %CO ₂ 700 ... 1100 hPa	±0.05 %CO ₂
With compensation, 0 ... 20 %CO ₂ 500 ... 1200 hPa	±0.015 % of reading/hPa
Without compensation (typical)	+0.15 % of reading/hPa
Humidity Dependence	
With compensation, 0 ... 20 %CO ₂ , 0 ... 100 %RH	±0.7 % of reading (at +25 °C (+77 °F))
Without compensation (typical)	+0.05 % of reading / %RH
O₂ Dependence	
With compensation, 0 ... 20 %CO ₂ , 0 ... 90 %O ₂	±0.6 % of reading (at +25 °C (+77 °F))
Without compensation (typical)	-0.08 % of reading / %O ₂
Flow Rate Dependence (for Flow-Through Model Option)	
< 1 l/min flow	No effect
1 ... 10 l/min flow	< 0.6 % of reading/ l/min
Start-up time at +25 °C (+77 °F)	< 10 s
Warm-up time for full spec.	< 4 min
Response Time (T₉₀)	
With standard filter	< 1 min
Flow-through model with > 0.1 l/min	< 1 min
With spray shield	< 2 min

Operating Environment

Operating temperature of CO ₂ measurement	-40 ... +60 °C (-40 ... +140 °F)
Storage temperature	-40 ... +70 °C (-40 ... +158 °F)
Pressure	
Compensated	500 ... 1100 hPa
Operating	< 1.5 bar
Humidity	0 ... 100 %RH, non-condensing
Gas Flow (for Flow-Through Option)	
Operating range	< 10 l/min
Recommended range	0.1 ... 0.8 l/min
Condensation prevention	Sensor head heating, when power on
EMC compliance	EN61326-1, Generic Environment
Chemical tolerance (temporary exposure during cleaning)	<ul style="list-style-type: none"> • H₂O₂ (2000 ppm, non-condensing) • Alcohol-based cleaning agents (for example ethanol and IPA) • Acetone • Acetic acid

Mechanical Specifications

Weight, probe	45 g (1.59 oz)
Materials	
Probe housing	PET plastic
Filter	PTFE membrane, PET plastic grid
Connector	Nickel plated brass, M12 / 5 pin
IP rating, probe body	IP65
Connector	M12 5-pin male
Dimensions	
Probe diameter	25 mm (0.98 in)
Probe length	96 mm (3.78 in)

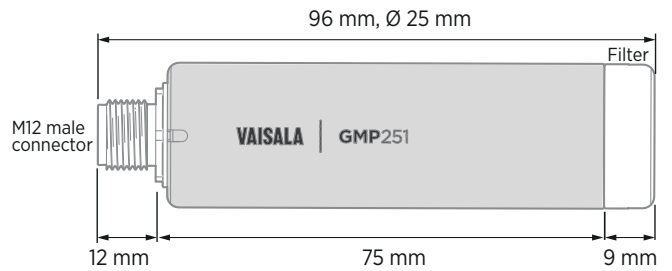

Inputs and Outputs

Analog outputs	<ul style="list-style-type: none">• 0 ... 5/10 V (scalable), min load 10 kΩ• 0/4 ... 20 mA (scalable), max load 500 Ω
Digital output	Over RS-485: <ul style="list-style-type: none">• Modbus• Vaisala Industrial Protocol

Operating Voltage

With digital output in use	12 ... 30 VDC
With voltage output in use	12 ... 30 VDC
With current output in use	20 ... 30 VDC

Power Consumption

Typical (continuous operation)	0.4 W
Maximum	0.5 W

Spare Parts and Accessories

Standard membrane filter	ASM211650SP
Porous sintered PTFE filter (extra protection)	DRW243649SP
Probe cable with open wires (1.5 m)	223263SP
Probe cable with open wires and 90° plug (0.6 m)	244669SP
Probe cable with open wires (10 m)	216546SP
Flow-through adapter with gas ports	ASM211697SP
USB cable for PC connection ¹⁾	242659
M170 connection cable for probe	CBL210472
Flat cable for GMP250 probes, M12 5-pin	CBL210493SP
Probe mounting clips (2 pcs)	243257SP
Probe mounting flange	243261SP
Calibration adapter	DRW244827SP
Spray shield	ASM212017SP

Transmitters

Indigo 200 series	See www.vaisala.com/indigo
-------------------	--

¹⁾ Vaisala Insight software for Windows available at www.vaisala.com/insight





Features

- Measurement range 0 ... 10 000 ppmCO₂
- Intelligent, stand-alone probe with analog and digital outputs
- Compatible with Indigo 200 transmitters and Vaisala Insight
- Wide operating temperature range -40 ... +60 °C
- IP65-classified housing
- 2nd-gen proprietary CARBOCAP® technology
- Full temperature and pressure compensations
- Integrated temperature measurement for CO₂ compensation purposes
- Compensations for background gases, O₂, and humidity
- Sensor head heated to prevent condensation

Vaisala CARBOCAP® Carbon Dioxide Probe GMP252 is a new intelligent probe for measuring carbon dioxide. This robust, stand-alone measurement device is designed for use in agriculture, refrigeration, greenhouses and demanding HVAC applications.

Benefits

- Superior long-term stability
- Reliable and accurate
- Calibration certificate included

GMP252 is suitable for harsh and humid CO₂ measurement environments where stable and accurate ppm-level CO₂ measurements are needed. GMP252 is based on Vaisala's unique, second-generation CARBOCAP technology that enables exceptional stability. A new type of infrared (IR) light source is used instead of the traditional incandescent light bulb, which extends the lifetime of GMP252.

GMP252 incorporates an internal temperature sensor for compensation of the CO₂ measurement according to ambient temperature. The effects of

pressure and background gas can also be compensated for. The measurement range is 0 ... 10 000 ppmCO₂ (measurements up to 30 000 ppmCO₂ are available with reduced accuracy). The operating temperature range of the probe is wide (-40 ... +60 °C (-40 ... +140 °F)), and the probe housing is classified as IP65. Condensation is prevented as the internal sensor head is heated.

GMP252 is resistant to dust and most chemicals, such as, H₂O₂ and alcohol-based cleaning agents.

Ease of Use

GMP252 is a compact probe with easy and fast plug-in, plug-out installation. The surface of the probe is smooth, which makes it easy to clean. The probe

provides several output options, including analog current and voltage outputs and digital RS-485 output with Modbus protocol.

GMP252 can be connected to Indigo 200 series transmitters for an extended selection of outputs and configuration options. See www.vaisala.com/indigo.

For easy-to-use access to field calibration, device analytics, and configuration functionality, the probe can be connected to Vaisala Insight PC Software (for Windows® 7, 8.1 and 10: see www.vaisala.com/insight).

Applications

GMP252 is ideal for agriculture, refrigeration, greenhouses and demanding HVAC applications where stable and accurate ppm-level CO₂ measurements are needed.

Technical Data

Measurement Performance

Measurement range	0 ... 10 000 ppmCO ₂ (up to 30 000 ppmCO ₂ with reduced accuracy)
Accuracy at 25 °C and 1013 hPa (incl. Repeatability and Non-Linearity)	
0 ... 3000 ppmCO ₂	±40 ppmCO ₂
3000 ... 10 000 ppmCO ₂	±2 % of reading
Up to 30 000 ppmCO ₂	±3.5 % of reading
Calibration Uncertainty	
at 2000 ppmCO ₂	±38 ppmCO ₂
at 10 000 ppmCO ₂	±105 ppmCO ₂
Long-Term Stability	
0 ... 3000 ppmCO ₂	±60 ppmCO ₂ /year
3000 ... 6000 ppmCO ₂	±150 ppmCO ₂ /year
6000 ... 10 000 ppmCO ₂	±300 ppmCO ₂ /year
Temperature Dependence 0 ... 10 000 ppmCO₂	
with compensation, -10 ... +50 °C	±0.05 % of reading/°C
with compensation, -40 ... +60 °C	< ±0.1 % of reading/°C
without temperature compensation at 2000 ppmCO ₂ (typical)	-0.5 % of reading/°C
Pressure Dependence	
with compensation at 0 ... 10 000 ppmCO ₂ , 500 ... 1100 hPa	±0.015 % of reading/hPa
without compensation (typical)	+0.15 % of reading/hPa
Humidity Dependence	
with compensation, 0 ... 10 000 ppmCO ₂ , 0 ... 100 %RH	±0.7 % of reading (at +25 °C (+77 °F))
without compensation (typical)	+0.05 % of reading/%RH
O₂ Dependence	
with compensation, 0 ... 10 000 ppmCO ₂ , 0 ... 90 %O ₂	±0.6 % of reading (at +25 °C (+77 °F))
without compensation (typical)	-0.08 % of reading/%O ₂
Start-Up, Warm-Up and Response Time	
Start-up time at +25 °C	< 12 s
Warm-up time for full spec.	< 2 min
Response time (T90) with standard filter	< 1 min
Response time (T90) with spray shield	< 3 min
Flow-Through Option	
Response time (T90) with > 0.1 l/min	30 s
Flow rate dependence < 1 l/min flow	no effect
Flow rate dependence 1 ... 10 l/min flow	< 0.6% of reading l/min
Gas flow operating range	< 10 l/min
Gas flow recommended range	0.1 ... 0.8 l/min

Operating Environment

Operating temperature of CO ₂ measurement	-40 ... +60 °C (-40 ... +140 °F)
Storage temperature	-40 ... +70 °C (-40 ... +158 °F)
Humidity	0 ... 100 %RH, non-condensing
Condensation prevention	Sensor head heating when power on
EMC compliance	EN61326-1, Generic Environment
Chemical tolerance (temporary exposure during cleaning)	<ul style="list-style-type: none"> H₂O₂ (2000 ppm, non-condensing) Alcohol-based cleaning agents (for example ethanol and IPA) Acetone Acetic acid
Pressure	
Compensated	500 ... 1100 hPa
Operating	< 1.5 bar

Mechanical Specifications

Weight, probe	58 g (2.05 oz)
Connector type	M12 5-pin male
IP rating, probe body	IP65
Materials	
Probe housing material	PBT plastic
Filter	PTFE
Connector	Nickel plated brass
Dimensions	
Probe diameter	25 mm (0.98 in)
Probe length	130 mm (5.12 in)

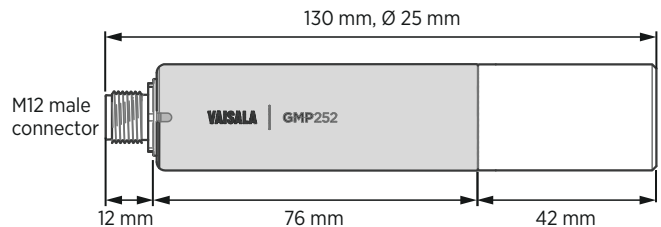

Inputs and Outputs

Digital output	Over RS-485: <ul style="list-style-type: none"> • Modbus • Vaisala Industrial Protocol
Analog output	<ul style="list-style-type: none"> • 0 ... 5/10 V (scalable), min load 10 kΩ • 0/4 ... 20 mA (scalable), max load 500 Ω
Operating voltage	
With digital output in use	12 ... 30 VDC
With voltage output in use	12 ... 30 VDC
With current output in use	20 ... 30 VDC
Power consumption	
Typical (continuous operation)	0.4 W
Maximum	0.5 W
When connected to Indigo 200 transmitter	
Analog output	3 voltage (V) or current (mA) outputs: <ul style="list-style-type: none"> • 0 ... 10 VDC / 0 ... 5 VDC / 0 ... 1 VDC / 1 ... 5 VDC (min load 1kΩ) • 0 ... 20 mA / 4 ... 20 mA (max load 500 Ω)
Relays	2 configurable relays
Power supply input	Nominal 24 V, range: <ul style="list-style-type: none"> • 15 ... 40 VDC • 20 ... 28 VAC
Power consumption	Max. 3.5 W (transmitter + probe total max. consumption)

Spare Parts and Accessories

Porous sintered PTFE filter for GMP252	DRW244221SP
Probe cable with open wires (1.5 m)	223263SP
Probe cable with open wires and 90° plug (0.6 m)	244669SP
Probe cable with open wires (10 m)	216546SP
Flow-through adapter with gas ports	ASM212011SP
USB cable for PC connection ¹⁾	242659
MI70 connection cable for probe	CBL210472
Flat cable for GMP250 probes, M12 5-pin	CBL210493SP
Probe mounting clips (2 pcs)	243257SP
Probe mounting flange	243261SP
Calibration adapter	DRW244827SP
Spray shield	ASM212017SP
Radiation shield DTR250	DTR250
Radiation shield DTR250 with pole mounting kit	DTR250A
Transmitters	
Indigo 200 series	See www.vaisala.com/indigo

¹⁾ Vaisala Insight software for Windows available at www.vaisala.com/insight



Features

- Two optional sampling methods: diffusion or pump aspiration
- User-friendly meter with multilingual user interface
- Numerical and graphical display of measurements
- Data can be logged and transferred to PC via MI70 Link software

The Vaisala CARBOCAP® Handheld Carbon Dioxide Meter GM70 is the demanding professional's choice for hand-held carbon dioxide measurement. The meter consists of the indicator (center) and probe, used either with the handle (left) or pump (right).

GM70 is a user-friendly meter for demanding spot measurements in laboratories, greenhouses and mushroom farms. The meter can also be used in HVAC and industrial applications, and as a tool for checking fixed CO₂ instruments.

GM70 has a short warm-up time and is ready for use almost immediately. It has a menu-based interface, a graphical LCD display and data logging capability.

Vaisala CARBOCAP® Technology

GM70 incorporates the advanced CARBOCAP sensor that has unique reference measurement capabilities. The measurement accuracy is not affected by dust, water vapor or most chemicals. The meter has a two-year recommended calibration interval.

Two Sampling Methods

The handle is for hand-held diffusion sampling. GM70 pump enables pump-aspirated sampling from locations difficult to access otherwise. It is also ideal for comparisons with fixed CO₂ transmitters.

Interchangeable Probes

GM70 uses the same probes as Vaisala CARBOCAP Carbon Dioxide Transmitter Series GMT220. By plugging different probes into the handle or pump, the user can easily change the measurement range of the GM70.

The meter can also be used as a calibration check instrument for Vaisala's fixed CO₂ instruments. GMW90 and GMP220 probes can also be adjusted by using the GM70 meter. GM70 has two probe inputs. Vaisala's relative humidity and dewpoint probes can also be used simultaneously with CO₂ measurement.

MI70 Link

The optional MI70 Link Windows® software and the USB connection cable form a practical tool for transferring logged data and real time measurement data from GM70 to a PC.

Benefits

- Proven Vaisala CARBOCAP® reliability
- Wide selection of measurement ranges
- Easy recalibration using the interchangeable probes
- Suitable for field checking of fixed CO₂ instruments
- Short warm-up time
- Compact and versatile

Technical Data

CO₂ Volume Concentration Measurement Performance, GMH70 Probe

Response Time (63 %)	
GMP221	20 s
GMP222	30 s
Measurement Ranges	
High concentrations, short probe (GMP221)	0 ... 2 % 0 ... 3 % 0 ... 5 %, 0 ... 10 %, 0 ... 20 %
Low concentrations, long probe (GMP222)	0 ... 2000 ppm, 0 ... 3000 ppm, 0 ... 5000 ppm, 0 ... 7000 ppm, 0 ... 10 000 ppm
Accuracy at 25 °C and 1013 hPa ¹⁾	
GMP221	±(1.5 % of range + 2 % of reading) ²⁾
GMP222	±(1.5 % of range + 2 % of reading)
Temperature dependence, typical	-0.3 % of reading/°C
Pressure dependence, typical	+0.15 % of reading/hPa
Long-term stability	< ±5 %FS / 2 years
Warm-up time	30 s, 15 min full specifications

1) Including repeatability, non-linearity and calibration uncertainty.

2) Applies for concentrations above 2 % of full scale.

Measurement Environment

Temperature	-20 ... +60 °C (-4 ... +140 °F)
Relative humidity	0 ... 100 %RH, non-condensing
Operation pressure	700 ... 1300 hPa
Flow range (diffusion sampling)	0 ... 10 m/s

Probe, Handle & Pump Mechanical Specifications

Sensor	Vaisala CARBOCAP®
Housing Material	
GMP221/222 probe	PC plastic
GMH70 handle	ABS/PC blend
GM70 Pump	Aluminium casing
Weight	
GMH70 with GMP221/222 probe	230 g
GM70 Pump with GMP221/222 probe	700 g

Probe, Handle & Pump Operating Environment

Storage temperature	-30 ... +70 °C (-22 ... +158 °F)
Storage humidity	0 ... 100 %RH, non-condensing

MI70 Measurement Indicator

Operating Environment

Operating temperature	-10 ... +40 °C (+14 ... +104 °F)
Operating humidity	0 ... 100 %RH, non-condensing
Storage temperature	-40 ... +70 °C (-40 ... +158 °F)

Inputs and Outputs

Max. no of probes	2
Power supply	Rechargeable NiMH battery pack with AC adapter or 4xAA size alkalines, type IEC LR6
PC interface	MI70 Link software with USB or serial port cable

Analog Output	
Scale	0...1 VDC
Output resolution	0.6 mV
Accuracy	0.2 % full scale
Temperature dependence	0.002 %/°C (0.01 %/°F) full scale
Minimum load resistor	10 kΩ to ground

Mechanical Specifications

Housing classification	IP54
Housing materials	ABS/PC blend
Weight	400 g (14 oz)

Compatibility

EMC compliance	EN61326-1, Portable Equipment
----------------	-------------------------------

Other

Menu languages	English, Chinese, Spanish, Russian, French, Japanese, German, Swedish, Finnish
Display	<ul style="list-style-type: none"> LCD with backlight Graphic trend display of any parameter Character height up to 16 mm (0.63 in)
Alarm	Audible alarm function
Data logging capacity	2700 real time data points
Logging interval	1 s to 12 h
Logging duration	1 min ... memory full
Resolution	0.01 %RH, 0.01 °C/°F, 0.01 hPa, 0.01 a _w , 10 ppm / 0.01 %CO ₂

Battery Operation Time

Typical charging time	4 hours
Operation Times	
Continuous use (with handle)	Better than 8 h at +20 °C (68 °F)
Continuous use (with pump)	Better than 5 h at +20 °C (68 °F) without load
Data logging use (one probe)	Up to 30 days depending on logging interval



Dimensions in mm (inches)

Spare Parts and Accessories

MI70 Link software with USB cable	219687
MI70 Link software with serial port cable	MI70LINK
Analog output cable for 0 ... 1 VDC	27168ZZ
Calibration adapter	26150GM
Weatherproof carrying case	MI70CASE3
Soft carrying case for diffusion handle and probe	MI70SOFTCASE
Battery, NiMH 4.8 V	26755
Spare probe (use the order form to define measurement range etc.)	GMP221, GMP222
Nafion Membrane Tubing	212807GM
Connection Cable for Fixed CO₂ Instruments	
GMT220, GMD20	GMA70
GMP343	DRW216050SP
GMW90 series	219980SP



GMW90 Series Carbon Dioxide, Humidity, and Temperature Transmitters for DCV



Features

- Measured parameters: carbon dioxide, temperature, and humidity (optional)
- Superior long-term stability with the next generation Vaisala CARBOCAP® sensor
- Accurate temperature and humidity measurements due to the low-power microglow infrared source
- Quick and easy installation and maintenance
- Calibrated, user-exchangeable measurement modules
- 3-point traceable CO₂ calibration (certification included)
- Both analog and digital communication (BACnet®/Modbus®)

GMW90 Series Carbon Dioxide, Temperature and Humidity Transmitters for HVAC are available with either a display opening or a solid front. An optional traffic light indication can also be selected.

GMW90 Series CARBOCAP® Carbon Dioxide, Temperature, and Humidity Transmitters are based on new measurement technology for improved reliability and stability. With the new technology the transmitter's inspection interval is extended to five years. Designed for demand controlled ventilation, these transmitters measure carbon dioxide and temperature, with the option for humidity measurements. The instruments come with a calibration certificate that meets traceability and compliance requirements.

Reliability from Unique Measurement Technology

GMW90 series transmitters use advanced Micro-Electro-Mechanical System (MEMS) technology for measuring carbon dioxide. The CARBOCAP® carbon dioxide

sensor's continuous reference measurement enables reliable and accurate readings and outstanding long-term stability also in buildings with round-the-clock occupancy.

The new generation CARBOCAP® sensor no longer uses an incandescent light bulb, which limits sensor lifetime. This unique sensor consumes very little power compared to other sensors on the market. As a result, instrument self-heating is low and humidity and temperature can be measured correctly.

Convenient Installation

GMW90 series transmitters have been designed for quick and easy installation and maintenance. Every model includes a display for easy startup and convenient maintenance. To protect the sensor from dust and dirt during construction and installation, the units can be cabled with

back-plate only. Electronics can be snapped on later at an appropriate phase in the construction project. DIP switches make it quick and easy to configure the transmitters.

Easy Calibration

Regular instrument maintenance guarantees a long product lifetime. Calibration is easiest done with the exchangeable measurement modules. Sensor traceability and measurement quality is easily maintained by snapping on a new module calibrated at Vaisala factory. The instrument can also be calibrated using a hand-held meter or reference gas CO₂ bottle. The service interfaces are easy to reach by simply sliding the cover down. The closed cover keeps the measurement environment stable during calibration and ensures a top-quality final result.

Technical Data

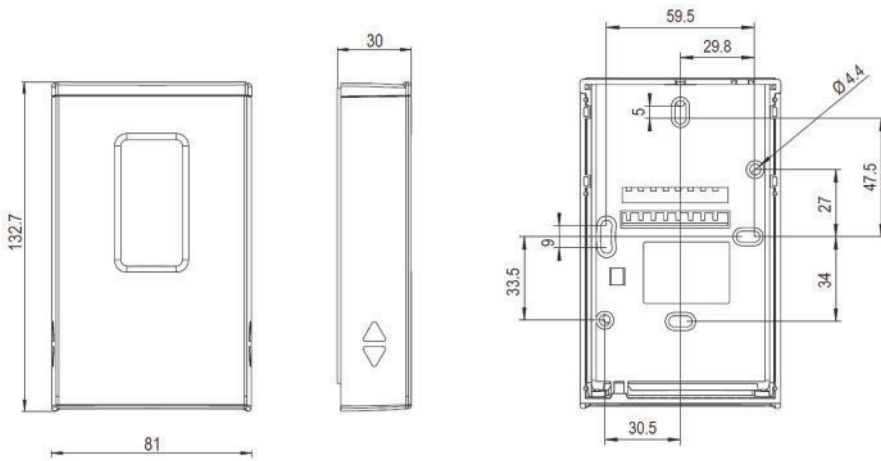

Dimensions in mm

Models

Model	Measurements	Output
GMW93	CO ₂ +T	3-wire, voltage output
GMW93D	CO ₂ +T	3-wire, voltage output with display
GMW94	CO ₂ +T	3-wire, current output
GMW94D	CO ₂ +T	3-wire, current output with display
GMW93R	CO ₂ +T+RH	3-wire, voltage output
GMW93RD	CO ₂ +T+RH	3-wire, voltage output with display
GMW93RA	CO ₂ +T+RH	3-wire, voltage output with display and CO ₂ indicator LEDs
GMW94R	CO ₂ +T+RH	3-wire, current output
GMW94RD	CO ₂ +T+RH	3-wire, current output with display
GMW95	CO ₂ +T	Digital (BACnet/Modbus) model
GMW95D	CO ₂ +T	Digital (BACnet/Modbus) model with display
GMW95R	CO ₂ +T+RH	Digital (BACnet/Modbus) model
GMW95RD	CO ₂ +T+RH	Digital (BACnet/Modbus) model with display
GMW90	CO ₂ +T	Configurable analog/digital models
GMW90R	CO ₂ +T+RH	Configurable analog/digital models

Technical Data

Measurement Performance

Carbon Dioxide

Measurement range	0 ... 5000 ppm
Stability in typical HVAC applications	Total accuracy at room temperature ±75 ppm at 600 and 1000 ppm incl. 5 years drift
Carbon dioxide sensor	Vaisala CARBOCAP® GM10
Accuracy:	
+20 ... +30 °C (+68 ... +86 °F)	±(30 ppm + 2 % of reading)
+10 ... +20 °C, +30 ... +40 °C (+50 ... +68 °F, +86 ... +104 °F)	±(35 ppm + 2.7 % of reading)
-5 ... +10 °C, +40 ... +55 °C (+23 ... +50 °F, +104 ... +131 °F)	±(45 ppm + 3.8 % of reading)

Temperature

Measurement range	-5 ... +55 °C (+23 ... +131 °F)
Temperature sensor	Digital temperature sensor
Accuracy:	
+20 ... +30 °C (+68 ... +86 °F)	±0.5 °C (±0.9 °F)
+10 ... +20 °C, +30 ... +40 °C (+50 ... +68 °F, +86 ... +104 °F)	±0.6 °C (±1.08 °F)
-5 ... +10 °C, +40 ... +55 °C (+23 ... +50 °F, +104 ... +131 °F)	±0.8 °C (±1.44 °F)

Relative Humidity

Measurement range	0 ... 95 %RH
Stability in typical HVAC applications	±0.5 %RH/year
Humidity sensor	Vaisala HUMICAP® 180R
Accuracy at temperature range +10 ... +40 °C (+50 ... +104 °F):	
0 ... 60 %RH	±2.5 %RH
60 ... 80 %RH	±3.0 %RH
80 ... 95 %RH	±4.0 %RH
Accuracy at temperature range -5 ... +10 °C, +40 ... +55 °C (+23 ... +50 °F, +104 ... +131 °F):	
0 ... 60 %RH	±3.5 %RH
60 ... 80 %RH	±4.0 %RH
80 ... 95 %RH	±5.0 %RH

1) Complies with CEC-400-2008-001-CMF

Operating Environment

Operating temperature	-5 ... +55 °C (+23 ... +131 °F)
Storage temperature	-30 ... +60 °C (-22 ... +140 °F)
Operating humidity	0 ... 95 %RH Dew point < +30 °C (+86 °F)



Optional decorative cover blends the transmitter into your interior design.

Inputs and Outputs

Supply voltage	18 ... 35 VDC, 24 VAC ± 20% 50/60 Hz
Service port	RS-485 line for temporary service use

Current Output Models

Outputs	0/4 ... 20 mA, 2 and 3 channel models
Loop resistance	0 ... 600 Ω
Power consumption	< 2 W

Voltage Output Models

Outputs	0 ... 5/10 V, 2 and 3 channel models
Load resistance	10 kΩ min.
Power consumption	< 1 W

Default Analog Scales

CO ₂	0 ... 2000 ppm
T	-5 ... +55 °C
RH	0 ... 100 %RH

Digital Models

Power consumption	< 1.5 W
Output type	RS-485 (galvanic isolation, 1.5 kV)
RS-485 end of line termination	Enable with jumper, 120 Ω

Supported protocols (selectable by DIP switch):

BACnet® MS/TP (selectable Master/Slave)	Address range, master mode: 0 ... 127 Address range, slave mode: 128 ... 255
Modbus® RTU	Address range: 0 ... 247

Mechanical Specifications

Standard housing color	White (RAL9003)
Housing material	ABS/PC, UL-V0 approved
Output connector	Screw terminals Max. wire size 2 mm ² (AWG14)
Service port connector	4-pin M8
Weight	163 g (5.75 oz)

1) RAL code is only indicative with potential small variations in color shade

Spare Parts and Accessories

CO ₂ module	GM10SP
Temperature Module (CO ₂ +T models)	TM10SP
Humidity and Temperature Module (CO ₂ +T+RH models)	HTM10SP
Decorative cover set (10 pcs)	236285
Connection cable for MI70	219980
USB cable for PC connection	219690

Compliance

EMC compliance	EN61326-1, Industrial Environment
IP rating	IP30

VAISALA

www.vaisala.com

GMW80 Series Carbon Dioxide, Humidity, and Temperature Transmitters for DCV



Features

- Superior stability due to 2nd-generation proprietary CARBOCAP® technology
- Improved accuracy due to low self-heating of microglow light source

Vaisala CARBOCAP® Carbon Dioxide, Humidity and Temperature Transmitter Series GMW80 is based on 2nd-generation technology for improved reliability and stability.

GMW80 series transmitters are designed to fulfill the needs for CO₂ measurements in standard demand-controlled ventilation applications. Temperature measurement is always included in the GMW80 series transmitters. Combined with humidity measurement, relay, and LED CO₂ level indication, GMW80 series provides you the flexibility needed for a variety of projects.

The CARBOCAP sensors measure CO₂ accurately immediately when powered on. As they have a built-in reference measurement they do not need a lengthy learning phase before the measured values are correct. Proper operation can be verified immediately after snapping on the device cover.

Easy Installation

With modern buildings often having hundreds of sensors, installation time per unit can be a significant cost factor. Returning to the building site to check sensor operation adds further costs.

The GMW80 series transmitters include a number of subtle design features that have been introduced to make installation and commissioning quick and easy.

The pull-out tab makes opening the transmitter faster than before, while also doubling as a quality check slip and holder for the anti-tamper screw. The backplate can be twisted onto pre-mounted screws, and the wiring can be done easily on the clearly marked backplate. The electronics can be snapped on later when the building automation system is commissioned.

For measurements in more demanding conditions (for example, dusty or humid installation locations), the GMW88 model provides an IP64-rated enclosure with a cable gland.

Reliable Operation

The GMW80 series transmitters are optimized for low maintenance. The 2nd-generation, low-power CARBOCAP technology enables a longer lifetime and superior stability than ever before. As the power consumption is low, the heat generated by the electronics does not distort the temperature inside the sensor. The internal reference in the CO₂ sensor guarantees the best stability and operation even in constantly occupied buildings without frequent readjustments.

The reliable operation and accurate measurement values of the GMW80 series transmitters contribute to the significant cost savings brought by demand-controlled ventilation.

Benefits

- Cost-efficient, affordable
- Reliable and maintenance-free operation for up to 15 years
- Easy to install, easy to use
- Versatile – works well in buildings occupied 24/7
- Ideal for demand-controlled ventilation

Technical Data

Models

GMW86P	CO ₂	CO ₂ current and voltage output, Pt1000
GMW83RP ¹⁾	CO ₂ +RH+T	Voltage outputs, Pt1000
GMW83DRP ¹⁾	CO ₂ +RH+T	Voltage outputs, Pt1000, Display
GMW83	CO ₂	Voltage outputs
GMW83A	CO ₂	Voltage outputs, CO ₂ indicator LEDs
GMW83D	CO ₂	Voltage outputs, Display
GMW84	CO ₂	CO ₂ current output
GMW84S	CO ₂	CO ₂ current output, Relay
GMW88	CO ₂	CO ₂ current and voltage output

¹⁾ Models with calibration certificate available (GMW83RPC/GMW83DRPC)

Measurement Performance

Carbon Dioxide

Measurement range	0 ... 2000 ppm
Accuracy across temperature range	
+20 ... +30 °C (+68 ... +86 °F)	±(30 ppm +3 % of reading)
+10 ... +20 °C (+50 ... +68 °F), +30 ... +40 °C (+86 ... +104 °F)	±(35 ppm +3.7 % of reading)
+0 ... +10 °C (+32 ... +50 °F), +40 ... +50 °C (+104 ... +122 °F)	±(40 ppm +4.8 % of reading)
Stability in typical HVAC applications	±(15 ppm + 2 % of reading) over five years
Warm-up time	1 min 10 min for full specification
Response time (63 %)	60 s GMW88 model: 7 min
Carbon dioxide sensor	Vaisala CARBOCAP® GM10

Temperature

Measurement range	0 ... +50 °C (+32 ... +122 °F)
Temperature sensor	On P models: Pt1000 RTD Class F0.15 IEC 60751 For analog outputs: Digital temperature sensor
Accuracy (GMW83, GMW84)	
+10 ... +30 °C (+50 ... +86 °F)	±0.5 °C (0.9 °F)
+0 ... +10 °C (+32 ... +50 °F), +30 ... 50 °C (+86 ... +122 °F)	±1 °C (1.8 °F)

Humidity

Measurement range	0 ... 95 %RH
Accuracy for temperature range +10 ... +30 °C (+50 ... +86 °F)	
0 ... 80 %RH	±3 %RH
80 ... 95 %RH	±5 %RH
Accuracy for temperature ranges 0 ... +10 °C (+32 ... +50 °F), +30 ... +50 °C (+86 ... +122 °F)	
0 ... 95 %RH	±7 %RH
Stability in typical HVAC applications	±2 %RH over 2 years
Product lifetime	> 15 years

Operating Environment

Operating temperature	0 ... +50 °C (+32 ... +122 °F)
Operating humidity	0 ... 95 %RH Dewpoint < 30 °C (+86 °F)
Storage temperature	Models without display: -40 ... +70 °C (-40 ... +158 °F) Models with display: -30 ... +70 °C (-22 ... +158 °F)
EMC compliance	EN61326-1, Industrial environment

Inputs and Outputs

Supply voltage	18 ... 35 VDC 24 VAC ±20 % 50/60 Hz
Max. current consumption at 18 VDC	GMW84 models: 70 mA Other models: 45 mA
Max. power consumption at 30 VAC	GMW83 models: 0.7 W GMW86 models and GMW88: 1 W GMW84 models: 1.2 W
Outputs	4 ... 20 mA and/or 0 ... 10 V
Current loop resistance (4 ... 20 mA)	0 ... 600 Ω
Voltage output load resistance	Min. 10 kΩ
CO ₂ output scale	0 ... 2000 ppm
Temperature output scale	0 ... +50 °C (+32 ... +122 °F)
Humidity output scale	0 ... 100 %RH
Passive temperature sensor (P models)	Pt1000 RTD
Temperature setpoint (T models)	10 kΩ potentiometer
Relay (S models)	1 pc, SPST-NO Max. 50 VDC / 50 VAC, 500 mA
CO ₂ indicator LED levels (A model)	Flashing red: > 2000 ppm Red: 1200 ... 2000 ppm Yellow: 800 ... 1200 ppm Green: < 800 ppm

Mechanical Specifications

IP rating	IP30 GMW88 model: IP64
Housing material	ABS/PC UL-V0 approved GMW88 model: PC
Housing color	White (RAL9003)
Output connector	Screw terminal
Max. wire size	2 mm ² (AWG14)
Weight	Plain and LED version: 114 g (4.02 oz) Display version: 124 g (4.37 oz) GMW88: 160 g (5.64 oz)

Spare Parts and Accessories

CO ₂ module	GM10SP80
INTERCAP® sensor	15778HM

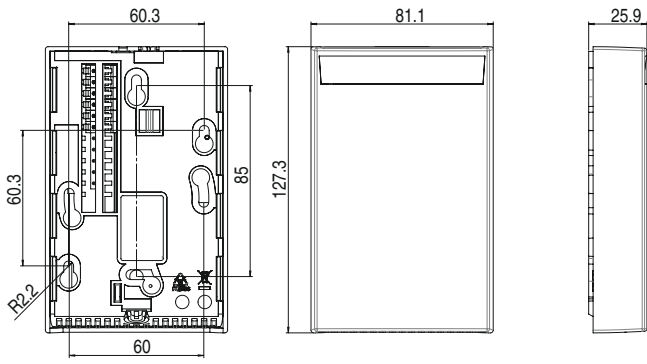

GMW83, GMW83A, GMW83RP, GMW84, GMW84S and GMW86P Dimensions (in mm)

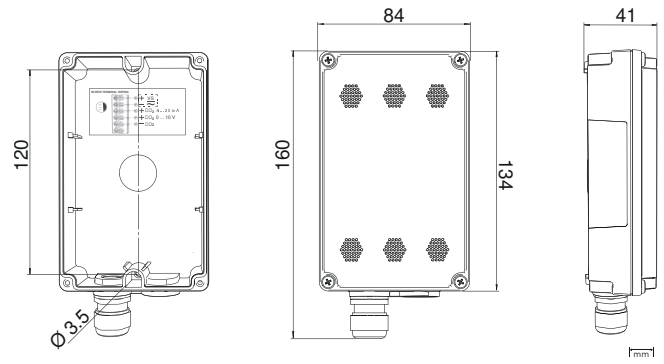

GMW88 Dimensions (in mm)

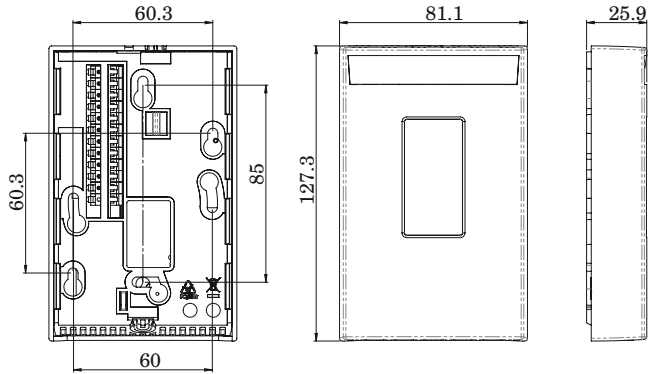

GMW83D and GMW83DRP Dimensions (in mm)





Features

- Versatile transmitters
- Reliable measurement with sensor inside the duct
- Incorporates Vaisala CARBOCAP® sensor - the silicon-based NDIR sensor
- Excellent long-term stability
- Negligible temperature dependence
- Ease of installation

The duct mounted Vaisala CARBOCAP® Carbon Dioxide Transmitter Series GMD20 is specially designed for demand controlled ventilation (DCV). The transmitters are easy to install and require no maintenance. The recommended calibration interval is five years.

Vaisala CARBOCAP® Technology

The GMD20 series transmitters use the silicon-based Vaisala CARBOCAP® sensor. The simple structure and reference measurement capabilities make this single-beam, dual-wavelength NDIR sensor extremely stable and reliable.

The temperature and flow dependencies of the sensor are negligible. In addition, the measurement accuracy is not affected by dust, water vapor, and most chemicals.

Versatile Transmitters

The GMD20 series transmitters can be used independently, or incorporated into building energy management systems. The series consists of duct mount units GMD20 and GMD20D. Version D is equipped with a display.

The compact sensor head design of the duct units fits inside the ventilation duct, eliminating the risk of leaking gaskets and measurement errors.

In addition to the standard 0 ... 20 mA, 4 ... 20 mA, and 0 ... 10 V outputs, there are two other options: one LonWorks® interface and a relay output. The relay output is standard with the display units.

Improve Indoor Air at Minimal Energy Costs

The use of GMD20 series transmitters ensures the best possible control of air quality and results in considerable savings in energy consumption, maintenance, and recalibration costs.

Technical Data

Measurement Performance

Carbon Dioxide

Measurement range	0 ... 2000 ppm (Nominal; can be calibrated for other ranges: 0 ... 5000 ppm, 0 ... 10 000 ppm, 0 ... 20 000 ppm)
Accuracy (including repeatability, non-linearity and calibration uncertainty)	± (2 % of range + 2 % of reading)
Long-term stability	< ±5 % of range / 5 years
Response time (63 %)	1 minute
Warm-up time	1 minute, 15 minutes full specifications

Operating Environment

Operating temperature	-5 ... +45 °C (-23 ... +113 °F)
Operating humidity	0 ... 85 %RH, non-condensing
Flow velocity	0 ... 10 m/s
Electromagnetic compatibility	EN61326-1, Generic Environment

Inputs and Outputs

Outputs	0 ... 20 or 4 ... 20 mA and 0 ... 10 V
Optional outputs	<ul style="list-style-type: none"> Relay LonWorks® interface
Resolution of analog outputs	8 bits
Recommended external load	<ul style="list-style-type: none"> Current output: max. 500 Ω Voltage output: min. 1 kΩ
Operating voltage	Nominal 24 VAC/DC (18 ... 30 VDC)
Connections	Screw terminals, wire size 0.5 ... 1.5 mm ²
Power consumption	< 2.5 W

Mechanical Specifications

Housing material	ABS plastic
Housing classification	IP65

Weight

GMD20	140 g (5 oz)
GMD20D	170 g (6 oz)

Spare Parts and Accessories

Display and relay option for GMD20	GMI21
Relay output option	GMR20
LonWorks® module with CO ₂ signal (not available when display option is added)	GML20
Serial COM adapter	19040GM
Hand-held meter for field verification	GM70

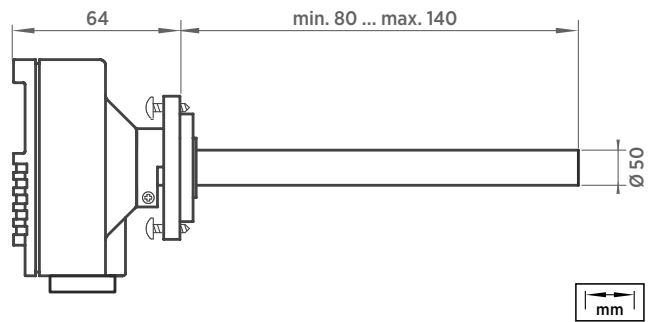

GMD20 Dimensions

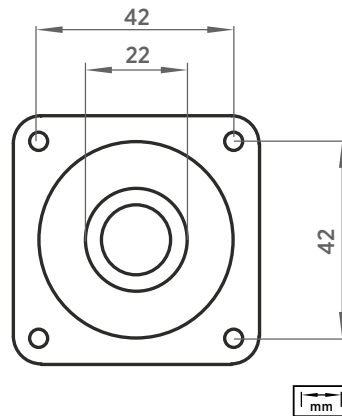

GMD20 Mounting Plate Dimensions



Features

- Continuous online measurement of moisture in oil
- Ball-valve installation – no need to shut down the process or drain the oil
- Proven Vaisala HUMICAP® sensor, used for over 15 years in oil applications
- Analog outputs, RS-232/485, LAN
- Modbus protocol support (RTU/ TCP)

Vaisala HUMICAP® Moisture and Temperature Transmitter Series for Oil MMT330 enables the fast and reliable detection of moisture in oil. MMT330 series transmitters can be used in online moisture monitoring and as control devices, allowing separators and oil driers to be started only when needed.

Benefits

- Easy field calibration and maintenance – compatible with Vaisala HUMICAP® Hand-Held Moisture Meter for Oil MM70
- Approved for installation in MAN Diesel & Turbo Two-Stroke Diesel Engines lubrication systems

Proper monitoring saves both oil and the environment. With the MMT330 series it is easy and economical to monitor the changes of moisture in oil.

Reliable Vaisala HUMICAP® Technology

The MMT330 series incorporates the latest-generation Vaisala HUMICAP® sensor, which is the result of over 15 years of field experience. It was developed for demanding moisture measurement in liquid hydrocarbons. The sensor's excellent chemical tolerance provides accurate and reliable measurement over a wide measurement range.

For Diverse Applications and Demanding Conditions

With a wide variety of probes, the transmitter can be used in lubrication systems, hydraulic systems, and transformers.

Indicates the Margin to Water Saturation

MMT330 measures moisture in oil in terms of the water activity (a_w), relative saturation (%RS), and temperature (T). Water activity or relative saturation indicate directly whether there is a risk of free-water formation. The measurement is independent of oil type and age.

Water Content as ppm Conversion

In addition to water activity, MMT330 can output ppm, the average mass concentration of water in oil. Vaisala has this conversion readily available for mineral transformer oil.

For other oils, the oil-specific conversion coefficients can be programmed into the transmitter if the water solubility of the oil is known.

Graphical Display of Measurement Data and Trends for Convenient Operation

MMT330 features a large numerical and graphical display with a multilingual menu and keypad. It allows users to easily monitor operational data, measurement trends, and access measurement history for the past 12 months.

The optional data logger, with real-time clock, makes it possible to generate over four years of measurement history and zoom in on any desired time or time frame.

The display alarm allows any measured parameter to be tracked, with freely configurable low and high limits.



The display shows measurement trends, real-time data, and measurement history.

Versatile Outputs and Data Collection

MMT330 can support up to three analog outputs; an isolated galvanic power supply and relay outputs are also available.

For serial interface the USB connection, RS-232, and RS-485 can be used.

In addition to the analog outputs, MMT330 provides Modbus RTU and TCP/IP communication protocol.

The data recorded by the data logger can be viewed on the local display or transferred to a PC with Microsoft Windows® software. The transmitter can also be connected to a network with an optional LAN interface, which enables a Ethernet connection. A USB service cable makes it easy to connect the MMT330 to a PC via the service port.

Easy Installation

With multiple options to choose from, the instrument can be tailored to meet the specific needs of each individual application and is delivered installation-ready and pre-configured for each delivery. Quick delivery time and global service network make MMT330 a perfect choice for any project.



Vaisala HUMICAP Hand-Held Moisture for Oil Meter MM70 is designed for field-checking MMT330 transmitters.

Installation Options



The MMT332 probe is installed using a flange. It is designed for high-pressure applications.

MMT332 for High Pressure Installations

Pressure range	0 ... 250 bar / 0 ... 3625 psia
Probe diameter	12 mm (0.5")
Installation flange	36 mm (1.4")
Temperature measurement range	-40 ... +180 °C (-40 ... 356 °F)

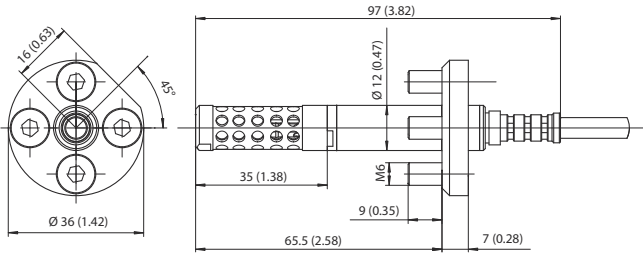

MMT332 Dimensions in mm (inches)



The MMT337 probe, with optional Swagelok connector, is ideal for tight spaces with a thread connection. The small probe is designed for integration into small diameter lines.

MMT337 with Small-Sized Probe

Pressure range	0 ... 10 bar / 0 ... 145 psia
Probe diameter	12 mm (0.5")
Temperature measurement range	-40 ... +180 °C (-40 ... 356 °F)

Installation	
Fitting body	R 3/8" ISO
Fitting body	1/2" ISO
Fitting body	NPT 1/2"

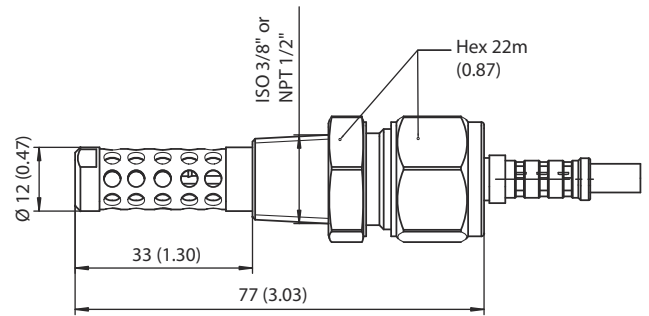

MMT337 Dimensions in mm (inches)



The MMT338 is ideal for installation into pressurized processes where the probe needs to be able to be removed while the process is running. The probe depth is adjustable.

MMT338 with Probe for Pipeline Installations

Pressure range with ball-valve	0 ... 40 bar / 0 ... 580 psia Up to 120 °C (248 °F) and 40 bar
Adjustable length	35 ... 157/379 mm (1.37 ... 6.2 /14.9")
Temperature measurement range	-40 ... +180 °C (-40 ... 356 °F)

Installation	
Fitting body	R1/2" ISO
Fitting body	NPT 1/2"
Ball-valve set	BALLVALVE-1
Sampling cell	DMT242SC2

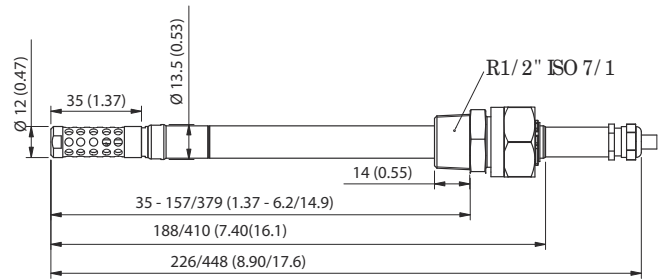

MMT338 Dimensions in mm (inches)

Technical Data

Measurement Performance

Water Activity

Measurement range a_w	0 ... 1
Response time (90%) at +20 °C in still oil (with stainless steel filter)	10 min.
Sensor	HUMICAP® 180 _L 2
Accuracy (Including Non-linearity, Hysteresis and Repeatability):	
0 ... 0.9	±0.02
0.9 ... 1.0	±0.03

Temperature

Measurement range	-40 ... +180 °C (-40 ... +356 °F)
Accuracy at +20 °C (+68 °F)	± 0.2 °C (0.36 °F)

Operating Environment

EMC compliance	EN61326-1, Industrial environment ¹⁾
Pressure range for probes	See probe specifications

Operating Temperature

For probes	Same as measurement ranges
For transmitter body	-40 ... +60 °C (-40 ... +140 °F)
With display	0 ... +60 °C (+32 ... +140 °F)

¹⁾ Note: Transmitter with display test impedance of 40 Ω is used in IEC61000-4-5 (Surge immunity)

General

Display	LCD with backlight, graphical trend display of any parameter
Menu languages	English, Chinese, Finnish, French, German, Japanese, Russian, Spanish, Swedish

Optional Data Logger with Real-time Clock

Logged parameters	Max. four with trend/min/max values
Logging interval	10 sec. (fixed)
Max. logging period	4 years, 5 months
Logged points	13.7 million points per parameter
Battery lifetime	Min. 5 years

Inputs and Outputs

Operating voltage	10 ... 35 VDC, 24 VAC ± 20 %
Operating voltage with optional power supply module	100 ... 240 VAC 50/60 Hz

Power Consumption at 20 °C (U_{in} 24 VDC)

RS-232	Max. 25 mA
U_{out} 2 x 0 ... 1 V / 0 ... 5 V / 0 ... 10 V	Max. 25 mA
I_{out} 2 x 0 ... 20 mA	Max. 60 mA
Display and backlight	+ 20 mA

Analog Outputs (2 Standard, 3rd Optional)

Current output	0 ... 20 mA, 4 ... 20 mA
Voltage output	0 ... 1 V, 0 ... 5 V, 0 ... 10 V
Accuracy of analog outputs at 20 °C	± 0.05 % full scale
Temperature dependence of the analog outputs	± 0.005 %/°C full scale

External Loads

Current outputs	$R_L < 500 \Omega$
0 ... 1V output	$R_L > 2 \text{ k}\Omega$
0 ... 5V and 0 ... 10V outputs	$R_L > 10 \text{ k}\Omega$
Max. wire size	0.5 mm ² (AWG 20) stranded wires recommended

Digital outputs	RS-232, RS-485 (optional)
Protocols	ASCII commands, Modbus RTU
Service connection	RS-232, USB
Relay outputs	0.5 A, 250 VAC, SPDT, potential-free (optional)

Ethernet Interface (Optional)

Supported standards	10BASE-T, 100BASE-TX
Connector	8P8C (RJ45)
IPv4 address assignment	DHCP (automatic), static
Protocols	Telnet, Modbus TCP/IP

WLAN Interface (Optional)

Supported standards	802.11b
Antenna connector type	RP-SMA
IPv4 address assignment	DHCP (automatic), static
Protocols	Telnet, Modbus TCP/IP
Security	WEP 64/128, WPA

Authentication / Encryption

- Open / no encryption
- Open / WEP WPA
- Pre-shared key / TKIP WPA
- Pre-shared key / CCMP (a.k.a. WPA2)

Mechanical Specifications

Weight	1.0 - 3.0 kgs (depends on selected probe, cable, and modules)
Sensor protection	Stainless steel grid standard filter/ Stainless steel grid filter for high flow rates (> 1 m/s)
Cable bushing	M20x1.5 for cable diameter 8 ... 11 mm (0.31 ... 0.43")
Conduit fitting	1/2" NPT
USB-RJ45 Serial Connection Cable (incl. MI70 Link software)	219685
Probe cable diameter	5.5 mm (0.2 in)
Standard probe cable lengths	2 m, 5 m or 10 m (6.6 ft, 16.4 ft, 32.8 ft) (Additional cable lengths available, please see order forms for details)
Housing material	G-AlSi 10 Mg (DIN 1725)
Interface cable connector (optional)	M12 series 8-pin (male)
Option 1	Female plug with 5 m (16.4 ft) black cable
Option 2	Female plug with screw terminals

Compliance

IP rating	IP66
IP rating with local display	IP65
NEMA rating with local display	4X

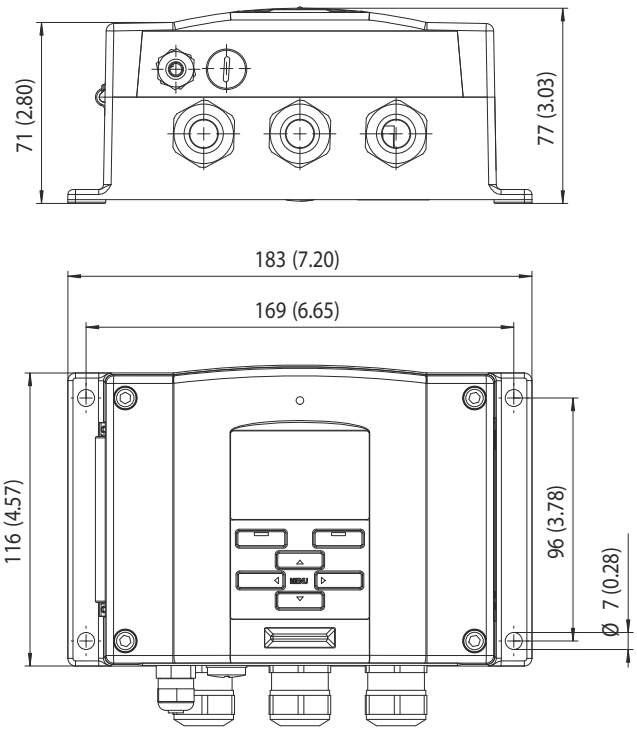

Dimensions in mm (inches)

Mounting Options

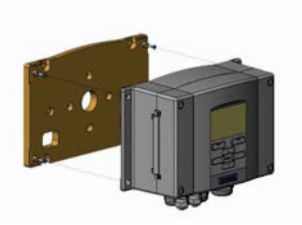

Mounting with Wall Mounting Kit

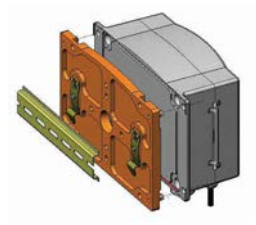

Mounting with DIN Rail Installation Kit

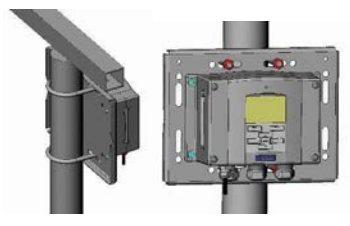

Pole Installation with Installation Kit for Pole or Pipeline



Mounting Rain Shield with Installation Kit





Features

- Continuous measurement of moisture in oil
- Proven Vaisala HUMICAP® sensor, over 15 years in oil applications
- Measurements in lubrication, hydraulic and transformer oils
- Excellent pressure and temperature tolerance
- Measuring water activity - ppm calculation for transformer oil
- Small size, easy to integrate
- Traceable calibration for measurement and analog outputs (certificates included)
- Applications: e.g. monitoring of transformer oil and of lubrication systems in marine and paper industry

Vaisala HUMICAP® Moisture and Temperature Transmitter Series for Oil MMT310 is a fast and reliable online detector for moisture in oil.

Reliable Vaisala HUMICAP® Technology

The MMT310 series incorporates the latest generation of the Vaisala HUMICAP® sensor, developed for demanding moisture measurement in liquid hydrocarbons. The sensor's excellent chemical tolerance provides accurate and reliable measurement over the wide measurement range.

Measuring Water Activity

MMT310 measures moisture in oil in terms of the water activity (a_w) and temperature (T). Water activity indicates directly whether there is a risk of free-water formation. The measurement is independent of oil type, age, and temperature.

Water Content as PPM Calculation for Transformer Oils

PPM units are traditionally used in transformer applications. They indicate the average mass concentration of water in oil. The ppm calculation for mineral oil based transformer oil is optional in the MMT310 series.

Diverse Applications and Demanding Conditions

MMT310 can be used in lubrication and hydraulic systems as well as in transformers. It can be used for on-line moisture monitoring and as a control function, allowing separators and oil purifiers to be started only when necessary.

Installation Options

MMT310 has two adjustable probe lengths. The transmitter can be ordered with a ball-valve set that enables the insertion and removal of the moisture probe for calibration, without the need to empty the oil system.

MMT317 has a small pressure-tight probe with optional Swagelok fittings.

An optional rain shield is available for outdoor installations.

Several Outputs, One Connector

MMT310 transmitters have two analog outputs and an RS-232 serial output. The output signals and the supply power travel in the same cable, the only cable connected to the unit.

Technical Data

Measurement Performance

Water Activity

Measurement range a_w (%RS)	0 ... 1 (0 ... 100 %)
Accuracy (Including Non-Linearity, Hysteresis, and Repeatability):	
0 ... 0.9 (0 ... 90 %)	±0.02
0.9 ... 1.0	±0.03
Response time (90 %) at +20 °C in still oil (with stainless steel filter)	10 min
Sensor	Vaisala HUMICAP® 180L2

Temperature

Measurement range	-40 ... +180 °C (-40 ... +356 °F)
Typical accuracy at +20 °C (68 °F)	±0.2 °C (±0.36 °F)
Sensor	Pt100 RTD Class F0.1 IEC 60751

Mechanical Specifications

IP rating	IP66
Weight example: MMT317 with 2 m cable (Weight depends on selected probe and cable)	476 g
Cable feed through alternatives	8-pole connector with 5 m cable Female 8-pin connector screw joint for cable diameter 4 ... 8 mm
Sensor protection	Stainless steel grid standard filter Stainless steel grid filter for high flow rates (> 1 m/s)

Materials

Transmitter housing	G-AISI 10 Mg
Transmitter base	PPS

Probe Cable Length

MMT317	2 m, 5 m, or 10 m
MMT318	2 m, 5 m, or 10 m

Probe installation MMT317

Swagelok®	NPT 1/2", ISO 3/8" or ISO 1/2"
-----------	--------------------------------

Probe installation MMT318

Fitting bodies	ISO 1/2", NPT 1/2"
----------------	--------------------

Spare Parts and Accessories

Rain shield	ASM211103
USB cable	238607
Stainless steel filter	HM47453SP
Stainless steel filter (high flow rate)	220752SP
Ball-Valve Set	BALLVALVE-1

Operating Environment

Operating temperature for electronics	-40 ... +60 °C (-40 ... +140 °F)
Storage temperature	-55 ... +80 °C (-67 ... +176 °F)
Pressure range for MMT318 with ball-valve up to 120 °C	0 ... 40 bar
Pressure range for MMT317	0 ... 10 bar
EMC compliance	EN61326-1, Industrial environment

Inputs and Outputs

Two analog outputs, selectable and scalable	0 ... 20 mA or 4 ... 20 mA 0 ... 5 V or 0 ... 10 V 1 ... 5 V available through scaling
Typical accuracy of analog output at +20 °C	±0.05 % full scale

Typical temperature dependence of analog output	0.005 %/°C (0.003 %/°F) full scale
---	------------------------------------

Serial output	RS-232C
Connections	8-pole connector with RS232C, current/ voltage outputs (two channels) and U_{in}

Operating voltage	10 ... 35 VDC
-------------------	---------------

External load	$R_L < 500 \Omega$
---------------	--------------------

Startup time after power-up	3 s
-----------------------------	-----

Minimum Operating Voltage

RS232C output	10 VDC
Analog output	15 VDC
Pressures above 10 bara (145 psia)	24 VDC

Power Consumption

RS232C	12 mA
U_{out} 10 V (10 k Ω)	12 mA
Channel 1 & channel 2	
I_{out} 20 mA (load 511 Ω)	50 mA
Channel 1 & channel 2	

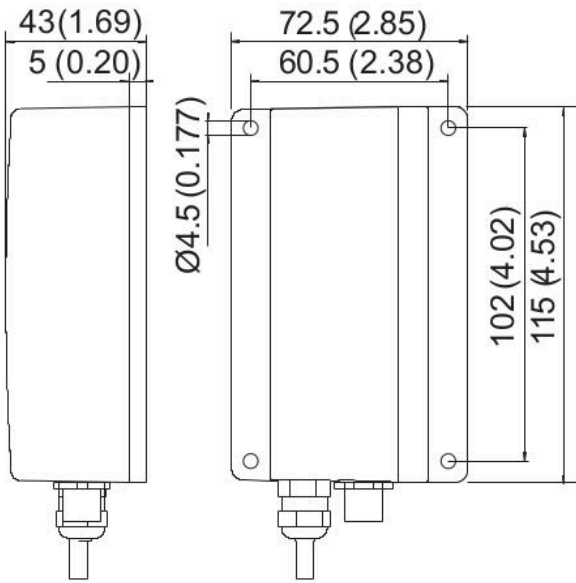

Transmitter body, dimensions in mm (inches)

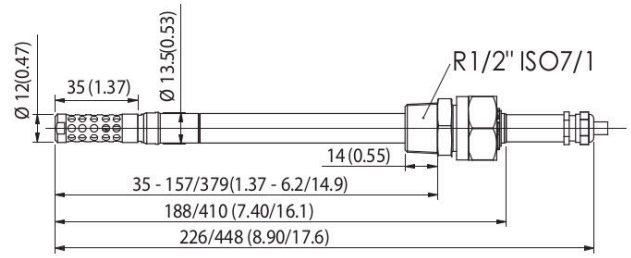

MMT318 probe, dimensions in mm (inches)

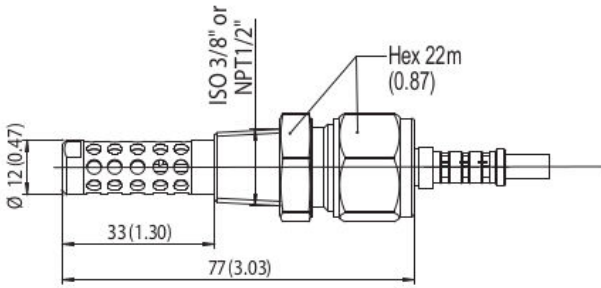

MMT317 probe, dimensions in mm (inches)



Features

- Continuous measurement of moisture in oil
- Measures in lubrication, hydraulic, and transformer oils
- Excellent pressure and temperature tolerance
- Proven Vaisala HUMICAP® sensor: over 20 years in oil applications
- Measures water activity - ppm calculation available for transformer oil
- Digital output RS-485 with Modbus
- Traceable calibration (certificate included)

Vaisala HUMICAP® Moisture and Temperature Transmitter for Oil MMT162 is an excellent economical solution for reliable on-line detection of moisture in oil.

Benefits

- Reliable
- Durable
- Small size, easy to integrate

Reliable Vaisala HUMICAP® Technology

MMT162 incorporates the latest generation of the Vaisala HUMICAP® sensor. The sensor is developed for demanding moisture measurement in liquid hydrocarbons and has been successfully used in oil applications for over two decades. The sensor's excellent chemical tolerance provides accurate and reliable measurement over the measurement range.

Water Activity Measurement

MMT162 measures moisture in oil in terms of the water activity (a_w) and temperature (T). Water activity indicates directly whether there is a risk of free water formation. The measurement is independent of oil type, age, and temperature. The ppm calculation for mineral oil based transformer oil is optional in MMT162.

Several Outputs - One Connector

MMT162 has two analog outputs that can be scaled and the measurement ranges changed. Additionally, the transmitter has an RS-485 serial output. The signals and the unit power travel in the same cable.

An optional LED cable enables a visual alarm.

Compact, Rugged, and Intelligent

Due to its compact size, MMT162 is quickly and easily installed in tight spaces. Units are delivered fully assembled - however, you can reconfigure them to suit your needs.

MM70 Moisture and Temperature Meter

In combination with an MM70 hand-held moisture and temperature meter, the MMT162 provides an ideal tool for on-site calibration. The MI70 hand-held indicator (included in the MM70 package) can be used as a display, communication, and datalogging device for the MMT162.

Technical Data

Measurement Performance

Water Activity

Measurement range	0 ... 1 a _w
Accuracy (Including Non-Linearity, Hysteresis, and Repeatability):	
0 ... 0.9 a _w	± 0.02 a _w
0.9 ... 1.0 a _w	± 0.03 a _w
Response time in oil flow (typical)	< 1 min (dry-wet)

Temperature

Accuracy at +20 °C (+68 °F)	± 0.2 °C (0.36 °F)
-----------------------------	--------------------

Moisture

Calculated moisture content in ppm for mineral transformer oil

Operating Environment

EMC compliance	EN61326-1, Industrial Environment
Operating temperature	-40 ... +60 °C (-40 ... +140 °F)
Storage temperature	-40 ... +80 °C (-40 ... +176 °F)
Oil temperature	-40 ... +80 °C (-40 ... +176 °F)
Oil flow	Some flow recommended
Pressure range, metal version	Up to 200 bar
Pressure range, plastic version	Up to 40 bar

Inputs and Outputs

Alarm level indication by analog signal	User selectable
Digital outputs	RS-485, non-isolated, Vaisala protocol, Modbus RTU protocol
Analog current output	0 ... 20 mA, 4 ... 20 mA
Analog voltage output	0 ... 5 V, 0 ... 10 V

Spare Parts and Accessories

Stainless steel filter (standard)	225356SP
Stainless steel filter for high flow (> 1 m/s)	221494SP
Connection cable for MM70 hand-held meter	219980
USB serial interface cable	219690
Sealing ring set (U-seal) ISO G1/2, 3 pcs	221525SP
Sealing ring set (copper) ISO G1/2, 3 pcs	221524SP
ISO 1/2" plug	218773
NPT 1/2" plug	222507
Sampling cell	DMT242SC
Sampling cell with Swagelok connectors	DMT242SC2

Connection Cables

0.32 m (1 ft) Shielded, M8 threaded	HMP50Z032
3.0 m (9.8 ft), Shielded, M8 threaded	HMP50Z300SP
5.0 m (16.4 ft), Shielded, M8 threaded	HMP50Z500SP
10 m (32.8 ft), Shielded, M8 threaded	HMP50Z1000SP
3 m, Shielded, connector 90° angle	231520SP
5 m, Shielded, connector 90° angle	231521SP
M8 threaded, Ch1 signal + Ch2 LED	MP300LEDCBL

Mechanical Specifications

Sensor	HUMICAP®
Cable connections (2 ports)	M8, 4-pin
Minimum Operating Voltage with	
RS-485 output	14 ... 28 VDC
Voltage output	16 ... 28 VDC
Current output	22 ... 28 VDC
Supply Current	
Normal measurement	20 mA + load current
External Load for	
Voltage output	Min. 10 kΩ
Current output	Max. 500 Ω
Housing Material	
Metal	AISI 316L
Plastic	PPS + 40 % GF
IP rating	IP66 (IP65 with plastic housing)
Mechanical Connections with Bonded Seal Ring (Washer)	
Metal version	G 1/2" ISO or NPT 1/2"
Plastic version	G 1/2" ISO
Weight	
With plastic housing	65 g (2.3 oz)
With metal housing	200 g (7 oz)

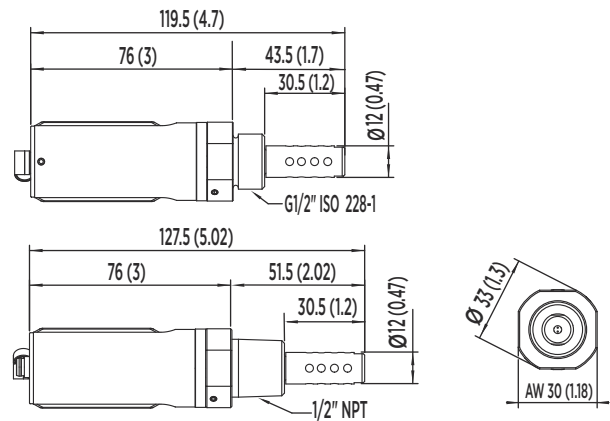
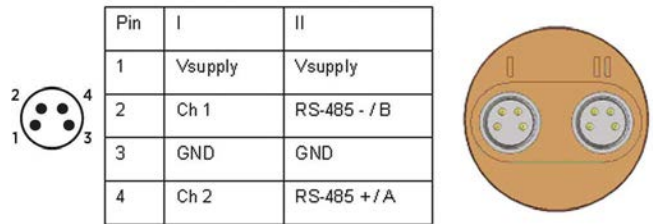

Dimensions in millimeters (inches)



Features

- Measurement independent of oil type, age and temperature
- In-line process checking through ball valve, no need to drain the oil
- Rugged and reliable construction
- Excellent pressure and temperature tolerance
- Data can be logged and transferred to a PC
- Proven Vaisala HUMICAP® Sensor: over 15 years in oil applications
- Compatible with Vaisala's fixed oil moisture instruments
- No reference oil needed for recalibration
- Traceable calibration (certificate included)

Vaisala HUMICAP® Handheld Moisture Meter for Oil MM70 enables reliable detection of moisture in oil. The probe can be inserted directly into the process pipe through a ball valve without draining the oil in the system.

MM70 measures moisture in oil in terms of the water activity (a_w) and temperature (T). Water activity directly indicates whether there is a risk of free water formation. The measurement is independent of oil type, age and temperature.

PPM Calculation Included

MM70 has an embedded model for expressing moisture as ppm in mineral transformer oil. The customer can enter up to three other oil models into the meter's memory.

Numerical and Graphical Display

MM70 features a multilingual, menu-based user interface and a backlit LCD display. The measurement parameters can be numerically and graphically displayed and logged into the meter's memory at the same time. An analog output option is also available.

Vaisala HUMICAP® Technology

MM70 incorporates the latest generation of the Vaisala HUMICAP® Sensor, developed for demanding moisture measurements in liquid hydrocarbons. The sensor's excellent chemical tolerance provides accurate and reliable measurement over the measurement range.

Speedy Service - Once a Year

The meter can be recalibrated by sending the probe to Vaisala Service, or customers can calibrate the instrument themselves using a standard relative humidity calibration.

Multi-Probe Operation

One or two probes can be connected simultaneously. Maintenance teams can use additional Vaisala dew point or relative humidity probes for other tasks. For example, a dew point probe is ideal for checking the moisture inside washed and dried oil tanks.

Connection to PC

The optional MI70 Link Windows® software in combination with a USB connection cable is used to transfer logged data and real time measurement data from the MM70 to a PC.

Technical Data

Measurement Performance, MMP78 Probe

Water Activity

Measurement range a_w	0 ... 1
-------------------------	---------

Accuracy (including nonlinearity, hysteresis and repeatability) when calibrated against salt solutions (ASTM E104-85):

0 ... 0.9	± 0.02
0.9 ... 1.0	± 0.03

Maximum achievable accuracy (including nonlinearity, hysteresis and repeatability) when calibrated against high-quality, certified humidity standards:

0 ... 0.9	± 0.01
0.9 ... 1.0	± 0.02

Response time (90%) at +20 °C (+68 °F) in still oil (with stainless steel filter)

Sensor	Vaisala HUMICAP® 180L2
--------	------------------------

Recommended recalibration interval	1 year
------------------------------------	--------

Typical long-term stability	better than 0.01 a_w / year
-----------------------------	-------------------------------

Temperature

Measurement range	-40 ... +100 °C (-40 ... +212 °F)
-------------------	-----------------------------------

Typical accuracy at +20 °C	± 0.2 °C (± 0.36 °F)
----------------------------	-------------------------------

Sensor	Pt100 RTD Class F0.1 IEC 60751
--------	--------------------------------

Probe Operating Environment

Operating temperature for electronics	-40 ... +60 °C (-40 ... +140 °F)
---------------------------------------	----------------------------------

Operating pressure range	max. 20 bar
--------------------------	-------------

Operating pressure range during installation through ball valve	max. 10 bar
---	-------------

Oil flow range	max. 1 m/s
----------------	------------

Typical temperature dependence of electronics	± 0.005 °C/°C (± 0.005 °F/°F)
---	--

EMC compliance	EN61326-1, Portable Equipment
----------------	-------------------------------

Probe Mechanical Specifications

Housing classification	IP65 (NEMA 4)
------------------------	---------------

Probe material	Stainless steel (AISI316L)
----------------	----------------------------

Housing material	APS/PC Blend
------------------	--------------

Cable length between probe and indicator	1.9 m, 10 m extension available
--	---------------------------------

Weight	506 g
--------	-------

MI70 Measurement Indicator

Operating Environment

Operating temperature	-10 ... +40 °C (+14 ... +104 °F)
-----------------------	----------------------------------

Operating humidity	0 ... 100 %RH, non-condensing
--------------------	-------------------------------

Storage temperature	-40 ... +70 °C (-40 ... +158 °F)
---------------------	----------------------------------

Inputs and Outputs

Max. no of probes	2
-------------------	---

Power supply	Rechargeable NiMH battery pack with AC adapter or 4xAA size alkalines, type IEC LR6
--------------	---

PC interface	MI70 Link software with USB or serial port cable
--------------	--

Analog Output	
---------------	--

Scale	0...1 VDC
-------	-----------

Output resolution	0.6 mV
-------------------	--------

Accuracy	0.2 % full scale
----------	------------------

Temperature dependence	0.002 %/°C (0.01 %/°F) full scale
------------------------	-----------------------------------

Minimum load resistor	10 kΩ to ground
-----------------------	-----------------

Mechanical Specifications

Housing classification	IP54
------------------------	------

Housing materials	ABS/PC blend
-------------------	--------------

Weight	400 g (14 oz)
--------	---------------

Compatibility

EMC compliance	EN61326-1, Portable Equipment
----------------	-------------------------------

Other

Menu languages	English, Chinese, Spanish, Russian, French, Japanese, German, Swedish, Finnish
----------------	--

Display	<ul style="list-style-type: none"> LCD with backlight Graphic trend display of any parameter Character height up to 16 mm (0.63 in)
---------	--

Alarm	Audible alarm function
-------	------------------------

Data logging capacity	2700 real time data points
-----------------------	----------------------------

Logging interval	1 s to 12 h
------------------	-------------

Logging duration	1 min ... memory full
------------------	-----------------------

Resolution	0.01 %RH, 0.01 °C/°F, 0.01 hPa, 0.01 a_w , 10 ppm / 0.01 %CO ₂
------------	---

Battery Operation Time

Typical charging time	4 hours
-----------------------	---------

Operation Times

Continuous use	48 h typical at +20 °C (68 °F)
----------------	--------------------------------

Data logging use	Up to a month
------------------	---------------

Spare Parts and Accessories

Weatherproof Carrying Case	MI70CASE4
Ball valve set (incl. fitting body & blanking plug)	HMP228BVS
Probe cable extension, 10 m	213107SP
MI70 Link software with USB cable	219687
MI70 Link software with serial port cable	MI70LINK
Analog output cable	27168ZZ
Sensor protection	HM47453SP
Dew point measurement probes	DMP74A/B
Relative humidity measurement probes	HMP75, HMP76, HMP77
Transmitter Connection Cables	
MMT162	219980SP
MMT310	DRW216050SP
MMT330	211339

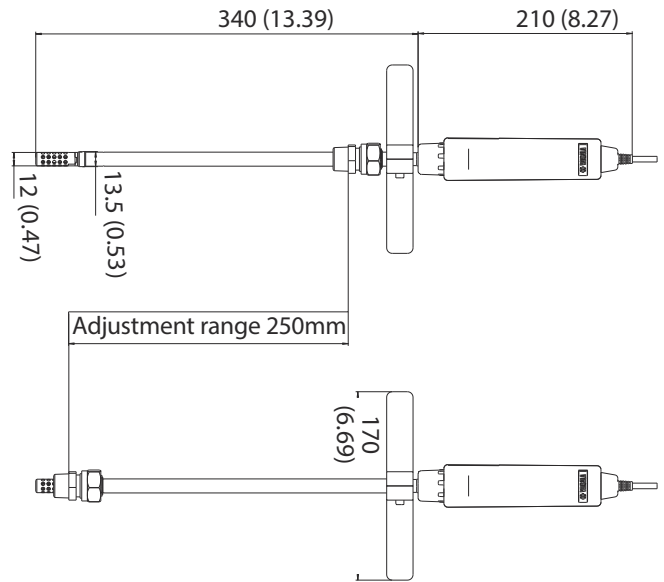

Probe dimensions in mm (inches)

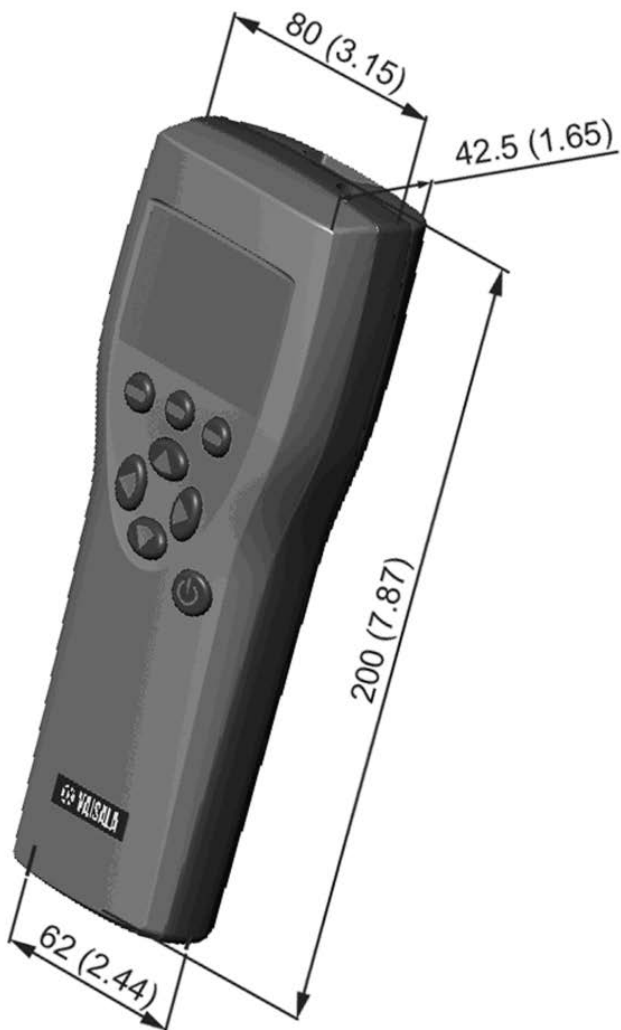

Indicator dimensions in mm (inches)

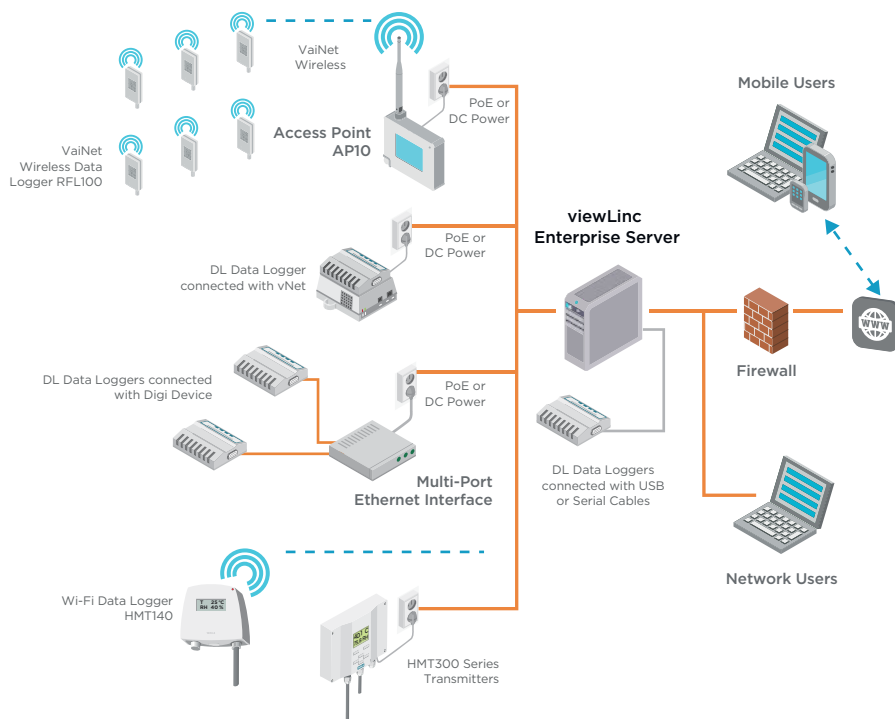

Features

- Software for continuous monitoring of temperature, humidity and other parameters
- Eight language versions, ideal for multi-site use and global monitoring
- Preconfigured and custom reports
- Configurable alarm notifications by email, SMS, or visual and audible alarms
- Scheduled threshold alarming and alarm notification delivery times to accommodate maintenance periods or work shifts
- Interactive tours — built-in guidance for first-time users

Vaisala viewLinc Enterprise Server allows you to network several types of Vaisala data loggers using a combination of wired and wireless connections. It supports small installations of one or two measurement points, or large systems that monitor thousands of locations. Designed for regulated and critical environmental monitoring, viewLinc ensures data integrity with a secure audit trail, access controls, encryption, and authorization levels that fulfill regulatory requirements.

Continuous Reliability

viewLinc runs as a Microsoft® Windows® service. If you are required to reboot your server, the viewLinc service restarts automatically. Users log in to viewLinc on any network computer or mobile device with a supported browser and can display viewLinc in several languages: English, German, French, Portuguese, Spanish, Swedish, Chinese, and Japanese. viewLinc supports UTF-8 compliant multi-byte character sets.

Licensing

A license key is required for each viewLinc Enterprise Server or Device Host installation (the number of devices permitted is defined by the license key).

Upgrading

Previous versions of viewLinc, 3.6.1 and higher, can upgrade to 5.0 directly. Depending on the server/database size, upgrade may take a few minutes or several hours (4 to 6).

System Requirements

- A dedicated server continuously available 24/7 to run viewLinc Enterprise Server software.
- One or more Vaisala data loggers, Vaisala wireless data loggers, or Vaisala HMT300 series transmitters.
- Vaisala cables, for connecting data loggers and setting up wireless transmitters.

- (optional) Additional dedicated or shared servers if you plan to manage devices at multiple sites (running viewLinc Device Host software).
- (optional) Remote display terminals, if you plan to provide monitoring in sites without user PCs.
- (optional) vNet and multi-port Ethernet devices, for connecting Vaisala data loggers to viewLinc through Ethernet.

Technical Data

Server Requirements

Availability	24 hours a day, 7 days a week
Server management	Connected to an uninterruptible power supply (UPS) Backup solution with support for open file backup
	Synchronizes time with a Network Time Protocol (NTP) server
Operating System	Windows Server® 2016 Windows Server® 2012 R2 (64-bit) Windows Server® 2008 R2 (64-bit) Windows® 10 (64-bit)
Virtual server support	VMWare
Application disk space	350 MB
Database disk space ¹⁾	200 KB/data point ^{2)/day}
Network traffic ³⁾	Approx. 100 KB/minute/device
Web interface protocol	TLS 1.2
Security certificate for web interface	Authorized TLS certificate and key ⁴⁾
Email encoding	RFC 2047
Secure email protocol	TLS 1.2

- 1) Not applicable to Device Host installation.
 2) Data points are device channels monitoring and recording data.
 3) Depends on number of devices, system configuration and type of communication devices used.
 4) Self-signed certificate and key can be generated during installation.

Requirements Based on System Size

System Size in Data Points	< 20	21 ... 399	400+
Dedicated or shared server	Either	Either	Dedicated
CPU	1.6 GHz dual core	1.6 GHz dual core	3.2 GHz quad core
RAM	8 GB	12 GB	16 GB
Disk space	1.5 GB/year for 20 data points	15 GB/year for 200 data points	73 GB/year for 1000 data points

Client Requirements

Internet browser	Google Chrome™ Microsoft® Internet Explorer® 11 Microsoft® Edge™
Computer clients	Any network computer with a supported Internet browser, a minimum 2.4 GHz CPU, and 4 GB of RAM.
Display and tablet clients	Touchscreen or mouse-operated panel with a supported Internet browser. Must be connected to the same network as viewLinc Enterprise Server.

Device Connection Requirements

Wireless Devices

RFL100 series	Connects using Vaisala VaiNet protocol. Requires installation of an AP10 access point.
HMT140 series	Connects using Wi-Fi protocol. Requires configuration with an HMT140 configuration cable.
300-series transmitter	Connects using WLAN or LAN interface.

Wired Devices

DL series using vNet device	vNet Power-over-Ethernet devices are 802.3af compliant and work with both end-point and mid-span systems. viewLinc Aware automatically detects and configures vNet devices. Power usage: Class 1 (0.75 to 1W, lowest power class) ¹⁾ Requires vNet device drivers (provided).
-----------------------------	--

DL series using multi-port Ethernet device

Power usage: Class 2 (4 to 6 W). Devices must be configured with static or reserved IP addresses. If the devices are being installed on different subnets, they need to be configured before being installed. Ethernet device drivers must be installed on each server used to connect Vaisala devices.

DL series using serial cable

Connect devices directly to viewLinc Enterprise Server or viewLinc Device Host using a serial-to-logger cable. Requires serial COM ports. ²⁾

DL series using USB cable

Connect devices directly to viewLinc Enterprise Server or viewLinc Device Host using a USB-to-logger cable. Requires USB ports. ²⁾

- 1) vNet devices maintain a low power rating by operating at a network speed of 10 Mbps. To ensure your network devices can operate at different speeds, set the network speed for the connected vNet port (see vNet User Guide).
 2) If the viewLinc Enterprise Server is installed on a virtual machine (VM), note that only VMWare® has been tested with viewLinc-supported modems. Please contact Vaisala technical support for list of currently supported modems.

Network Ports

Port	Port Type	Used By
443	TCP	Client connections to user interface
771	TCP	vNet and multi-port Ethernet devices
950	TCP	Moxa serial-to-WiFi devices
6767	UDP	HMT140
12600	TCP/UDP	VaiNet access points, viewLinc Enterprise Server connection with vNet or Device Host

viewLinc 5.0 includes software developed by the OpenSSL Project for use in the OpenSSL Toolkit. (<http://www.openssl.org/>)



Features

- One AP10 supports up to 32 VaiNet data loggers
- Powered by Power over Ethernet (PoE) or DC adapter
- Minimal infrastructure and no signal amplifiers needed
- Uses HTTPS communication and encryption to ensure secure data transmission
- Chirp Spread Spectrum wireless modulation is resistant to multi-path fading
- Secure firewall and tamper-proof data backup

VaiNet Access Point AP10 is a wireless networking hardware device for Vaisala's proprietary wireless technology: VaiNet. AP10 can connect up to 32 VaiNet wireless data loggers (such as the RFL100) to Vaisala viewLinc Monitoring System.

AP10 in the viewLinc Monitoring System

AP10 access point transfers measurement data from wireless VaiNet data loggers to the viewLinc Enterprise Server, and enables the remote configuration and management of VaiNet data loggers by the viewLinc administrator. A wired Ethernet network connection between AP10 and viewLinc Enterprise Server is required.

Registration of new data loggers is handled by viewLinc Enterprise Server software. Whenever a new data logger is added to the system, AP10 automatically

identifies it and forwards its information to viewLinc. Once accepted in viewLinc, VaiNet data loggers stay synchronized, even in situations where other nearby VaiNet networks overlap.

Data Integrity

Data is encrypted during VaiNet transfers to protect against eavesdropping, data tampering, and transfer errors. Both the access point and the viewLinc Enterprise Server software verify that the data has been received correctly. Once the data is verified, it is stored to viewLinc's secure database and protected from tampering and loss.

Redundancy

Redundancy of the wireless connection is achieved through use of multiple VaiNet access points and free connection capacity in the system. If a VaiNet data logger has a connection problem, it will automatically connect to another available access point in the system. At least two access points with free capacity are needed for failover to function.

Technical Data

Wireless

Networking standards	Vaisala VaiNet
Modulation	LoRa™ chirp spread spectrum modulation
Output power	14 dBm (25 mW)
Antenna	Non-removable external antenna
Typical range (indoors)	At least 100 m (328 ft)
Maximum number of access points in an area	8
Frequency Bands	
Model AP10E	868 MHz (Europe)
Model AP10A	915 MHz (North America, Australia, and New Zealand)
Safety	
Electrical safety	EN/UL/IEC 61010-1
RF exposure	KDB 447498 (United States) RSS-102 Issue 5 (Canada)
EMC and Radio Standards	
EMC compliance	EN/IEC 61326-1, industrial environment
Model AP10E	ETSI EN 300 220-2 EN 301 489-1 EN 301 489-3
Model AP10A	FCC title 47 part 15.247 (FCC ID: 2AO39-AP10A) ICE RSS-247 (IC: 23830-AP10A) AS/NZS 4268

Operating Environment

Operating environment	Indoor use
Operating temperature	-20 ... +60 °C (-4 ... +140 °F)
Operating humidity	0 ... 90 %RH, non-condensing
Storage temperature	-20 ... +60 °C (-4 ... +140 °F)

Mechanical Specifications

IP rating	IP30
Housing color	White
Mounting methods	Screws, tie-wrap
Weight	350 g (12.3 oz)
Dimensions (H × W × D)	311 × 133 × 37 mm (12.24 × 5.24 × 1.46 in)
Materials	
Housing	PC/ABS blend
Display window	Polyester
Antenna	ABS

Spare Parts and Accessories

Power supply for AP10	244784SP
Mounting kit	245679SP

Inputs and Outputs

Operating voltage using dedicated power supply connector	10 ... 30 VDC
PoE power class	Class 0
Power consumption	Max. 13 W
Internal clock	Synchronizes with Network Time Protocol (NTP) server
Supported devices	Up to 32 VaiNet compatible data loggers
Compatible viewLinc versions	5.0 and above
User interfaces	Web browser interface Local touchscreen interface
User interface languages	English, German, French, Portuguese, Spanish, Swedish, Chinese, Japanese
Ethernet Interface	
Supported standards	10BASE-T, 100BASE-TX
IPv4 address assignment	DHCP (automatic), static
Connectors	
Power supply connector	2.0 mm center pin locking type DC power jack
Service port	Micro-USB (2.0)
Expansion port	USB type A (2.0)
Ethernet	8P8C (RJ-45)

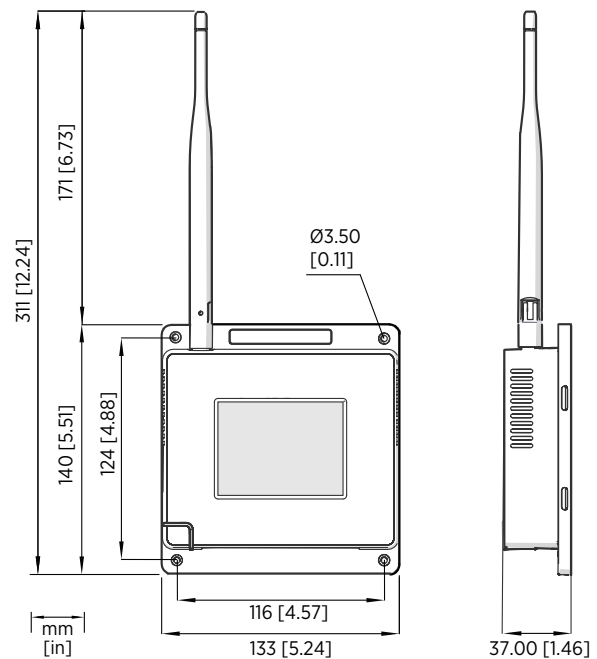

AP10 Access Point Dimensions



Features

- Industry-leading temperature and relative humidity measurement precision
- Detachable high-accuracy RH and temperature probes
- 30-day First In First Out (FIFO) memory buffer
- Optional magnetic mounting bracket available
- Typical battery life of 18 months
- Uses standard alkaline batteries
- Traceable to SI units through national metrology institutes ¹⁾
- Cost-effective alternative to chart recorders

¹⁾ Measurement results are traceable to the International System of Units (SI) through national metrology institutes (NIST USA, MIKES Finland, or an equivalent) or accredited calibration laboratories.

RFL100 Data Logger uses Vaisala's proprietary VaiNet wireless technology. It can be used to monitor temperature and humidity in a wide range of environments: warehouses, production areas, cleanrooms, laboratories, fridges, cold storage areas, and freezers down to -196 °C (-320.8 °F).

VaiNet Wireless

RFL100 connects wirelessly to Vaisala viewLinc Monitoring System, which provides real-time trends, alarms, and historical reporting. VaiNet wireless technology is based on the LoRa[®] modulation technique to provide a robust wireless signal that is extremely reliable over long distances and in complex, obstructed conditions. This wireless technology allows the data logger's signal to travel over 100 m (328 ft) indoors without the aid of signal amplifiers or repeaters. Wireless communications are encrypted to ensure data integrity and security.

Measurements are updated and stored every 60 seconds, and sent from the data logger every four minutes. In case of temporary network disruptions, the data logger can record up to 30 days of

measurements that are automatically transmitted to the viewLinc Enterprise Server software when communications are restored. Recorded data can also be downloaded directly from RFL100 through the USB port.

Versatility and Convenience

RFL100 requires no startup configuration, and the included mounting bracket supports several installation methods. Detailed custom display shows the latest measurement results, alarm and battery status, and signal strength of the current access point connection. The housing is classified IP54 to protect the device from dust and cleaning.

RFL100 is powered by two standard AA size 1.5 V batteries (LR6 alkaline or FR6 lithium) for 18 months of operation at approximately 20 °C (68 °F). There is no need for costly battery replacements between recommended calibrations.

Detachable Probe

RFL100 supports several probe types for humidity and temperature measurement. The probes use Vaisala HUMICAP[®] humidity sensors and platinum temperature sensors (Pt100 and Pt1000 type) for superior stability. Probes can be integrated with the RFL100 housing or connected using a cable.

The probe is detachable, and easy to switch out for calibration. viewLinc Enterprise Server detects the changed probe information automatically and maintains accurate and complete historical records.

Probe Options

HMP115 Probe



Probe for general purpose humidity and temperature measurement. Ideal choice for ambient measurement. Designed to be integrated with RFL100 housing for minimum footprint, but can be connected using a cable as well.

Plastic grid filter provides the fastest response time. For added sensor protection, select the membrane filter or the PTFE filter.

HMP110 Probe



Robust stainless steel probe for humidity and temperature measurement in demanding conditions. Suitable for measurement inside chambers, fridges, and freezers. Cable probe option only. Probe diameter 12 mm (0.47 in).

Plastic grid filter provides the fastest response time. For added sensor protection, select the membrane filter, the PTFE filter, or the stainless steel sintered filter.

TMP115 Probe



Wide-range temperature-only probe for measurement in extreme conditions. Can be integrated with the RFL100 housing or connected using a cable.

Available as 50 cm (1 ft 7.7 in) and 3 m (9.8 ft) long versions. Length includes probe body and sensor tip. Sensor tip withstands immersion in glycol and liquid nitrogen. Sensor tip diameter 4.8 mm (0.19 in).

Probe Model	Measurement	Measurement Temperature Range	IP Rating	Typical Mounting Accessories
HMP115	RH + T	-40 ... +60 °C (-40 ... +140 °F)	IP54	No accessories needed when integrated to RFL100
HMP115T	T	-40 ... +60 °C (-40 ... +140 °F)	IP54	
HMP110	RH + T	-40 ... +80 °C (-40 ... +176 °F)	IP65	<ul style="list-style-type: none"> • Duct installation kit • Mounting clamps
HMP110T	T	-40 ... +80 °C (-40 ... +176 °F)	IP65	<ul style="list-style-type: none"> • Mounting nuts
TMP115	T	-196 ... +90 °C (-320.8 ... +194 °F)	IP67 (sensor tip) IP65 (probe body)	<ul style="list-style-type: none"> • Thermal dampener block • Flat cable for insertion to chambers and freezers via door seal

Technical Data

Wireless

Networking standards	Vaisala VaiNet
Modulation	LoRa™ chirp spread spectrum modulation
Output power	14 dBm (25 mW)
Antenna	Internal
Typical range (indoors)	At least 100 m (328 ft)
Range with line-of-sight	Over 500 m (1640 ft)
Frequency bands	868 MHz (Europe) 915 MHz (North America, Australia, and New Zealand)
Safety	
Electrical safety	EN/UL/IEC 61010-1
RF exposure	KDB 447498 (United States) RSS-102 Issue 5 (Canada)
EMC and Radio Standards	
EMC compliance	EN/IEC 61326-1, industrial environment
868 MHz model	ETSI EN 300 220-2 EN 301 489-1 EN 301 489-3
915 MHz model	FCC title 47 part 15.247 (FCC ID: 2AO39-RFL100A) ICE RSS-247 (IC: 23830-RFL100A) AS/NZS 4268

Memory

Sample capacity	30 days (43200 samples per channel)
Memory type	Non-volatile EEPROM
Memory mode	Ring buffer (FIFO)
Sampling rate	One sample / channel / minute (nonchangeable)

Operating Environment

Storage temperature	-40 ... +60 °C (-40 ... +140 °F)
Operating humidity	0 ... 100 %RH, non-condensing
Operating Temperature ¹⁾	
with alkaline batteries	+2 ... +60 °C (+35.6 ... +140 °F)
with lithium batteries	-20 ... +60 °C (-4 ... +140 °F)

¹⁾ For both alkaline and lithium, battery temperature operating specifications apply.

General

Compatible probes	HMP115, HMP115T HMP110, HMP110T (cabled only) TMP115
Compatible viewLinc versions	5.0 and above
Batteries	2 × AA sized, 1.5 V (LR6 or FR6)
Clock battery	CR 1/3N (3 V lithium button cell)
Operation time at 20 °C (without external power supply)	18 months
Internal clock accuracy	±30 s/month Synchronizes with Network Time Protocol (NTP) server

Mechanical Specifications

Housing color	White
Mounting methods	Screws, tie-wrap, hook, or magnetic mounting bracket (optional accessory)
Probe interface	4-pin female M8 connector
Service port	USB 2.0 with Micro-USB connector
IP rating	IP54
Dimensions (H × W × D) with HMP115 Probe	
Without mounting bracket	158 × 62 × 31 mm (6.22 × 2.4 × 1.22 in)
With mounting bracket	186 × 68 × 36.5 mm (7.32 × 2.68 × 1.44 in)
Weight	
With batteries (2 pcs alkaline), HMP115 probe, and magnetic mounting bracket	254 g (8.96 oz)
Materials	
Housing	PC/ABS blend
Display window	PMMA (acrylic)
Sealings	TPE

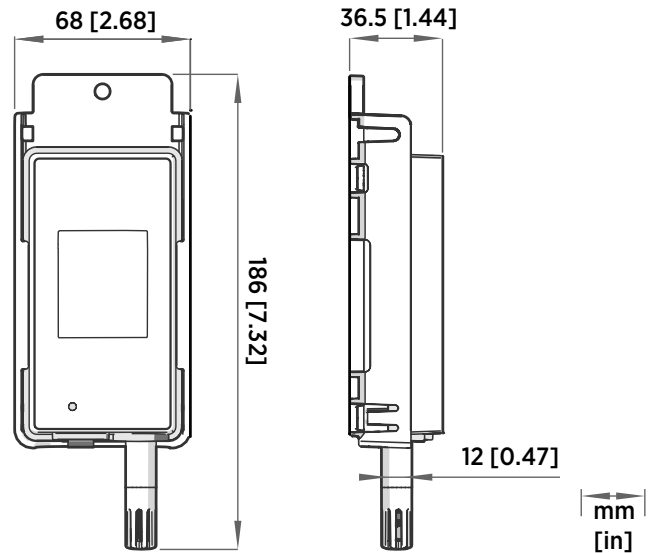

RFL100 Dimensions with HMP115 Probe

HMP110/T Probe Measurement Performance

Relative Humidity

Measurement range	0 ... 100 %RH
-------------------	---------------

Accuracy in Temperature Range 0 ... +40 °C (+32 ... +104 °F) ¹⁾

0 ... 90 %RH	±1.5 %RH
90 ... 100 %RH	±2.5 %RH

Accuracy in Temperature Range -40 ... 0 °C, +40 ... +80 °C (-40 ... +32 °F, +104 ... +176 °F) ¹⁾

0 ... 90 %RH	±3.0 %RH
90 ... 100 %RH	±4.0 %RH

Factory Calibration Uncertainty at +20 °C (68 °F) ²⁾

0 ... 90 %RH	±1.1 %RH
90 ... 100 %RH	±1.8 %RH

Humidity sensor	Vaisala HUMICAP® 180R
-----------------	-----------------------

Stability	±2 %RH over 2 years
-----------	---------------------

Temperature

Measurement range	-40 ... +80 °C (-40 °F ... +176 °F)
-------------------	-------------------------------------

Accuracy over Temperature Range

at 0 ... +40 °C (+32 °F ... +104 °F)	± 0.2 °C (0.36 °F)
at -40 ... 0 °C, +40 ... +80 °C (-40 ... +32 °F, +104 ... +176 °F)	± 0.4 °C (0.72 °F)

Factory calibration uncertainty ²⁾	± 0.2 °C (0.36 °F)
---	--------------------

Temperature sensor	Pt1000 RTD Class F0.1 IEC 60751
--------------------	---------------------------------

1) Includes non-linearity, hysteresis, and repeatability.

2) Small variations possible; see also calibration certificate.

HMP115/T Probe Measurement Performance

Relative Humidity

Measurement range	0 ... 100 %RH
-------------------	---------------

Accuracy in Temperature Range 0 ... +40 °C (+32 ... +104 °F) ¹⁾

0 ... 90 %RH	±1.5 %RH
90 ... 100 %RH	±2.5 %RH

Accuracy in Temperature Range -40 ... 0 °C, +40 ... +60 °C (-40 ... +32 °F, +104 ... +140 °F) ¹⁾

0 ... 90 %RH	±3.0 %RH
90 ... 100 %RH	±4.0 %RH

Factory Calibration Uncertainty at +20 °C (68 °F) ²⁾

0 ... 40 %RH	±0.6 %RH
40 ... 75 %RH	±1.0 %RH

Humidity sensor	Vaisala HUMICAP® 180R
-----------------	-----------------------

Stability	±2 %RH over 2 years
-----------	---------------------

Temperature

Measurement range	-40 ... +60 °C (-40 °F ... +140 °F)
-------------------	-------------------------------------

Accuracy over Temperature Range

at 0 ... +40 °C (+32 ... +104 °F)	± 0.2 °C (0.36 °F)
at -40 ... 0 °C, +40 ... +60 °C (-40 ... +32 °F, +104 ... +140 °F)	± 0.4 °C (0.72 °F)

Factory calibration uncertainty ²⁾	± 0.1 °C (0.18 °F)
---	--------------------

Temperature sensor	Pt1000 RTD Class F0.1 IEC 60751
--------------------	---------------------------------

1) Includes non-linearity, hysteresis, and repeatability.

2) Small variations possible; see also calibration certificate.

TMP115 Probe Measurement Performance

Temperature

Measurement range	-196 ... +90 °C (-320.8 ... +194 °F)
-------------------	--------------------------------------

Accuracy over Temperature Range ¹⁾

at -196 ... -90 °C (-320.8 ... -130 °F)	± 2.5 °C (4.5 °F)
---	-------------------

at -90 ... -30 °C (-130 ... -22 °F)	± 0.75 °C (1.35 °F)
-------------------------------------	---------------------

at -30 ... 0 °C (-22 ... +32 °F)	± 0.5 °C (0.9 °F)
----------------------------------	-------------------

at 0 ... +50 °C (+32 ... +122 °F)	± 0.25 °C (0.45 °F)
-----------------------------------	---------------------

at +50 ... +90 °C (+122 ... +194 °F)	± 0.75 °C (1.35 °F)
--------------------------------------	---------------------

Factory calibration uncertainty ²⁾	± 0.08 °C (0.128 °F)
---	----------------------

Temperature sensor	Pt100 RTD Class A IEC 751
--------------------	---------------------------

1) Includes non-linearity, hysteresis, and repeatability.

2) Small variations possible; see also calibration certificate.

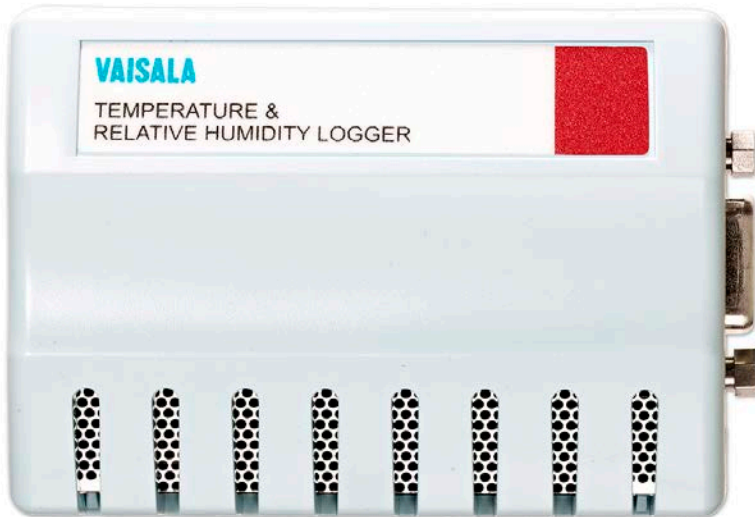

Features

- Industry-leading temperature and relative humidity measurement precision
- High accuracy, adjustable timebased digital recording
- Printed reports for any time period
- 10-year battery
- Ability to perform validation and continuous monitoring with the same model
- Traceable to SI units through national metrology institutes
- Superior alternative to chart recorders and hard-wired systems
- Integrated high-accuracy RH sensor

Vaisala's 2000 series of data loggers are designed to provide high accuracy measurements for temperature, relative humidity and an analog sensor of your choice.

The 2000 logger combines internal temperature and RH sensors with optional external channels for either current or voltage inputs for recording parameters such as differential pressure, CO₂ level, particles, or conductivity. The 2000 logger can also include a Boolean channel for door switches or alarm contacts. The 2000 logger includes calibrations traceable to SI units through national metrology institutes.¹⁾

Ideal for use in standalone or networked applications, the 2000 data logger connects directly to a PC with USB, or installs to an existing network via

Ethernet, Power over Ethernet, or WiFi. Each data logger contains a 10-year battery and onboard memory for recording at the point of measurement. With autonomous power and recording capacity, data is immune to network and power interruptions.

The DL2000 data loggers can be used with Vaisala software, either viewLinc or vLog, to download, display, and analyze environmental data. The viewLinc monitoring system provides 24/7

multi-stage alarm notification, remote, real-time monitoring and gap-free data. The vLog software is a simple solution for validation/ mapping applications. The measurement results are traceable to the international system of units (SI) through national metrology institutes (NIST USA, MIKES Finland, or equivalent) or ISO/IEC 17025 accredited calibration laboratories.

All reports are customizable and can be exported to spreadsheets and PDF to provide records that meet the requirements of 21 CFR Part 11 and Annex 11.

¹⁾ The measurement results are traceable to the international system of units (SI) through national metrology institutes (NIST USA, MIKES Finland, or equivalent) or ISO/IEC 17025 accredited calibration laboratories.

Technical Data

General

Size	85 × 59 × 26 mm (3.4 × 2.3 × 1 in)
Weight	76 g (2.7 oz.)
Interfaces	RS-232 serial, USB, WiFi, Ethernet and Power over Ethernet (vNet)
Mounting	3M Dual Lock™ fasteners
Power source	Internal 10-year lithium battery (Battery life specified at +23 °C with sample interval of 1 min or longer)
Internal clock	Accuracy ±1 min/month at -25 °C ... +70 °C (-13 ... +158 °F)
Electromagnetic compatibility	FCC Part 15 and CE EN 50581:2012 EN 55032:2012/AC:2013 Class B EN 61326-1:2013
RoHS compliance	2011/65/EU
PC Software	
Monitoring, alarming and reporting	viewLinc
Validation/mapping GxP environments	vLog VL for validated vLog SP for non validated
Adding loggers to an existing OPC-compatible monitoring system	OPC Server

Channel Configuration and Recording Span

Model	Channel Types			
	CH 1	CH 2	CH 3	CH 4
2000-20R	T	RH		
2000-3CR	T	RH	4 ... 20 mA	
2000-35R	T	RH	0 ... 5 VDC	
2000-3AR	T	RH	0 ... 10 VDC	
2000-4BR	T	RH	Boolean	Boolean

Number of Channels Enabled¹⁾

Sample Interval	1	2	3	4
10 seconds	14.1 days	7.1 days	4.7 days	3.5 days
1 minute	2.8 months	1.4 months	23.8 days	21.2 days
5 minutes	1.2 years	7.1 months	4.7 months	3.5 months
15 minutes	3.5 years	1.7 years	1.2 years	10.6 months
1 hour	13.9 years	7.0 years	4.6 years	3.5 years

¹⁾ Temperature channel must be enabled when the RH channel is enabled.

Memory

Sample capacity	122 197 12-bit samples
Memory type	Non-volatile EEPROM
Memory modes	User-selectable wrap (FIFO) or stop when memory is full. User-selectable start and stop times.
Sampling rates	User-selectable from once every 10 seconds to once a day.

Internal Sensors

Internal Temperature Sensor

Calibrated measurement range ¹⁾	-25 ... +70 °C (-13 ... +158 °F)
Operating range	-35 ... +85 °C (-31 ... +185 °F)
Initial accuracy ²⁾	± 0.10 °C over +20 °C ... +30 °C (± 0.18 °F over +68 °F ... +86 °F)
	± 0.20 °C over -25 °C ... +70 °C (± 0.36 °F over -13 °F ... +158 °F)
One Year Accuracy ³⁾	± 0.15 °C over +20 °C ... +30 °C (± 0.27 °F over +68 °F ... +86 °F)
	± 0.25 °C over -25 °C ... +70 °C (± 0.45 °F over -13 °F ... +158 °F)
Resolution	0.02 °C at +25 °C (0.04 °F at +77 °F)

Internal RH Sensor

Calibrated measurement range ¹⁾	45 %RH at +10 °C (+50 °F) 10 ... 80 %RH at +25 °C (+77 °F) 45 %RH at +45 °C (+113 °F)
Operating range	0 ... 100 %RH (non-condensing)
Initial accuracy ²⁾	± 1 %RH over 10 ... 80 %RH at +20 ... +30 °C (+68 ... +86 °F)
	± 1.5 %RH over 80 ... 90 %RH at +20 ... +30 °C (+68 ... +86 °F)
	± 2 %RH over 10 ... 90 %RH at -20 ... +70 °C (-4 ... +158 °F)
One year accuracy ³⁾	± 2 %RH over 10 ... 90 %RH at +20 ... +30 °C (+68 ... +86 °F)
	± 3 %RH over 10 ... 90 %RH at -20 ... +70 °C (-4 ... +158 °F)
Resolution	0.05 %RH

¹⁾ Custom calibration points available upon request including full ICH coverage.

²⁾ Initial accuracy includes all known influence quantities present at the time of calibration including calibration uncertainty, mathematical fit, data logger resolution, hysteresis and reproducibility.

³⁾ One Year Accuracy includes all known influence quantities present during the operation of a data logger over the course of one year including Initial Accuracy and Long Term Drift. Not included is any drift related to atypical contamination or misuse.

Current Loop and Voltage Inputs

Input Type	Current Loop	Analog Voltage
Available ranges	0 ... 22 mA	0 ... 5 VDC, 0 ... 10 VDC
Resolution	5.5 µA	0.025 % F.S.
Accuracy	±0.15 % F.S. at +25 °C (+77 °F)	±0.15 % F.S. at +25 °C (+77 °F)
Input impedances	75 Ω ¹⁾	>1 MΩ
Isolation	One common per logger	One common per logger
Overload protection	40 mA max. (reverse-polarity protected)	±24 VDC max. (reverse-polarity protected)

¹⁾ Termination resistance plus approximately 0.4 volt drop through a protection diode.

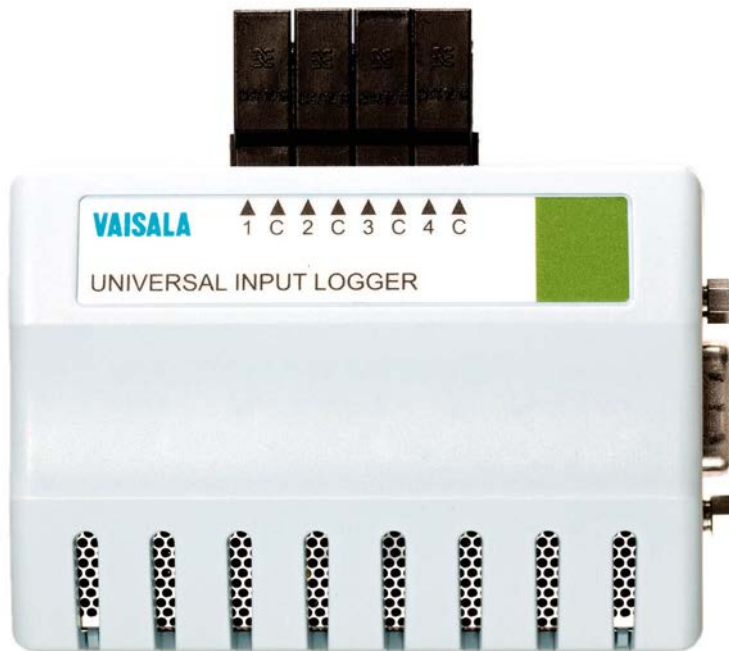

Features

- 10-year battery and large onboard memory
- Single and multi-channel models with up to four input channels
- Easily set scaling and measurement units for recording
- Time-based digital recording in a range of sample intervals
- Multiple connectivity options - USB, Ethernet, WiFi
- Optional vNet cradle for Ethernet or Power over Ethernet connectivity
- Traceable to SI units through national metrology institutes.
- Two year limited warranty

DL4000 series of data loggers are designed to interface with a wide range of transducers, transmitters, and sensors with a DC voltage or 0 - 20 mA current loop output.

DL4000 is a simple solution for recording and monitoring pressure, flow, fluid level, PH, electrical properties, moisture and gas concentrations.

Ideal for use in standalone or networked applications, the DL4000 Universal Input logger connects directly to a PC with USB or installs to an existing network via Ethernet, Power over Ethernet or WiFi. Each logger contains a 10-year battery and onboard memory for recording a wide range of variables at the point of measurement. With autonomous power and recording capacity, data is immune to network and power interruptions.

The DL4000 data loggers can be used with Vaisala software, either viewLinc or vLog, to download, display, and analyze environmental data. The viewLinc monitoring system provides 24/7 multi-stage alarm notification, remote, real-time monitoring and gap-free data. The vLog software is a simple solution for validation/mapping applications. The DL4000 data loggers include calibrations traceable to SI units through national metrology institutes.²⁾

All reports are customizable and can be exported to spreadsheets and PDF to provide records that meet the requirements of 21 CFR Part 11 and Annex 11.

Choose the DL4000 VL series data logger for GxP-compliant environments and the DL4000 SP series for non-GxP applications.

²⁾ Measurement results are traceable to the international system of units (SI) through national metrology institutes (NIST USA, MIKES Finland, or equivalent) or ISO/IEC 17025 accredited calibration laboratories.

Technical Data

General

Operating range	-40 ... +85 °C (-40 ... +185 °F) and 0 ... 100 %RH (non-condensing)
Interfaces	RS-232 serial USB Wifi module Ethernet and Power over Ethernet (vNet)
Weight	76 g (2.7 oz)
Size	85 × 59 × 26 mm (3.4 × 2.3 × 1 in)
Mounting	3M Dual Lock™ fasteners
PC software	Graphing & Reporting Software vLog SP for SP-series vLog VL for VL-series viewLinc for continuous monitoring & alarming OPC Server to add on to existing OPC compatible monitoring systems
Internal clock	Accuracy ±1 min/month at -25 ... +70 °C (-13 ... +158 °F)
Electromagnetic compatibility	FCC Part 15 and CE EN 50581:2012 EN 55032:2012/AC:2013 Class B EN 61326-1:2013
RoHS compliance	2011/65/EU
Power source	Internal 10-year lithium battery (Battery life specified with sample interval of 1 min or longer)

Memory

Memory type	Non-volatile EEPROM
Data sample capacity	120 000 12-bit samples
Memory modes	User-selectable wrap (FIFO) or stop when memory is full. User-selectable start and stop times.
Sampling rates	User-selectable from once every 10 seconds to once a day. (Battery life specified with sample interval of 1 min or longer)
Recording span	Recording span depends upon sample interval selected and number of channels enabled. Please see table above.

Recording Span

Sample Interval	Number of Channels			
	1	2	3	4
10 seconds	13.8 days	6.9 days	4.6 days	3.4 days
1 minute	2.7 months	1.3 months	27.7 days	20.8 days
5 minutes	1.1 years	6.9 months	4.6 months	3.4 months
15 minutes	3.4 years	1.7 years	1.1 years	10.4 months
1 hour	13.6 years	6.8 years	4.5 years	3.4 years

Current Loop and Voltage Inputs

Input Type	Current Loop	Analog Voltage
Available ranges	0 ... 20mA	0 ... 5 VDC, 0 ... 10 VDC
Resolution	5.5 µA	0.025 % F.S.
Accuracy	±0.15 % F.S. at +25 °C (+77 °F)	±0.15 % F.S. at +25 °C (+77 °F)
Input impedances	75 Ω	> 1 MΩ
Isolation	One common per logger	One common per logger
Overload protection	40 mA max. (reverse-polarity protected)	±24 VDC max. (reverse-polarity protected)

Channel Configurations

Model	1, 2 or 4 Channels
4000-405	0 ... 5 VDC
4000-40A	0 ... 10 VDC
4000-40C	0 ... 20 mA



Features

- Industry-leading precision and accuracy
- Printed reports for any time period
- 10-year battery
- Validation and continuous monitoring with the same model
- Two year limited warranty
- Superior alternative to chart recorders and hard-wired systems
- Timebase calibrated over the operating temperature range
- Adjustable time based recording
- Snap-in logger cradle for easy network connectivity
- Two probe options give high accuracy – from -90 °C to +70 °C
- Traceable to SI units through national metrology institutes.

The 1000/1400 temperature data loggers include the VL series for regulated environments and the SP series for non FDA/GxP regulated industries.

VL series and SP series dataloggers

The VL series of data loggers, together with vLog VL software, provide a superior, high accuracy solution for use in FDA/GxP regulated environments by ensuring tamperproof files and electronic records that meet 21 CFR Part 11 requirements.

The 1000/1400 temperature data loggers include calibrations traceable to SI units through national metrology institutes.³⁾

The SP-series provides a compact, easily deployable, highly accurate measurement and recording device. Coupled with vLog SP software for

downloading, displaying, analyzing and reporting of recorded environmental data, the SP-series was designed for use in non FDA/GxP regulated environments.

Optional browser-based viewLinc software provides 24/7 multi-stage alarm notification and remote monitoring for both the VL and SP series of data loggers.

Applications

The 1000/1400 temperature data loggers are ideal for monitoring and validation of:

- Refrigerators and freezers (to -90 °C)
- Incubators

- Stability Chambers
- Warehouses
- Ambient conditions

Autonomous Power and Recording Capacity

Each data logger contains a 10-year battery and onboard memory for recording at the point of measurement. With autonomous power and recording capacity, data is immune to network and power interruptions.

³⁾ Measurement results are traceable to the international system of units (SI) through national metrology institutes (NIST USA, MIKES Finland, or equivalent) or ISO/IEC 17025 accredited calibration laboratories.

Technical Data

General

Interfaces	RS-232 serial, USB, Ethernet, WiFi, PoE network interface available
PC software	Graphing & Reporting Software vLog SP for SP series vLog VL for VL series viewLinc for continuous monitoring and alarming OPC Server to add on to existing OPC compatible monitoring systems
Internal clock	Accuracy ±1 min/month -25 °C ... +70 °C (-13 °F ... +158 °F)
Logger operating/ Storage range	-40 °C ... +85 °C (-40 °F ... +185 °F) 0 ... 100 %RH non-condensing
Power source	Internal 10-year lithium battery (Battery life specified with sample interval of 1 min or longer)
Electromagnetic compatibility	FCC Part 15 and CE EN 50581:2012 EN 55032:2012/AC:2013 Class B EN 61326-1:2013
RoHS compliance	2011/65/EU



VL-1000-21x

Mechanical Specifications

Size	85 × 59 × 26 mm (3.4 × 2.3 × 1 in)
Weight	76 g (2.7 oz)
Mounting	3M Dual Lock™ fasteners Snap-in connector locks provide secure probe connections

Internal Temperature Sensor

1000-21x series	Precision-tolerance epoxy-encapsulated NTC thermistor
-----------------	---

Memory

1000-2XX series	48 100 12-bit samples
1400-44X series	85 300 12-bit samples
Memory type	Non-volatile EEPROM
Memory modes	User selectable: wrap (FIFO) or stop when memory is full. User selectable start time. User selectable stop time (VL-series only).
Sampling rates	User-selectable (in 10 second intervals) from once every 10 seconds to once a day.



VL-1000-22x

Recording Span: 1000-2xx

Sample Interval	Number of Channels Enabled	
	1	2
10 seconds	5.5 days	2.7 days
1 minute	1.1 months	16.7 days
5 minutes	5.5 months	2.7 months
15 minutes	1.3 years	8.3 months
1 hour	5.4 years	2.7 years

Technical Data

Recording Span: 1400-44x

Sample Interval	Number of Channels Enabled			
	1	2	3	4
10 seconds	9.8 days	4.9 days	3.2 days	2.4 days
1 minute	1.9 months	29.6 days	19.7 days	14.8 days
5 minutes	9.8 months	4.9 months	3.2 months	2.4 months
15 minutes	2.4 years	1.2 years	9.8 months	7.4 months
1 hour	9.7 years	4.8 years	3.2 years	2.4 years



VL-1400-44x

Temperature Probe Accessories

Thermal Dampening Block, for use in refrigerators and freezers, simulates a glycol bottle to reduce viewLinc alarms generated by opening and closing a door.



EPT Series Temperature Probes

Sensor Models

"N" range external probes	EPT-23N-XXN and EPT-22W-XXN
Operating/storage range	-40 °C ... +95 °C (-40 ... +203 °F)
Connector color code	Black
"V" range external probes	EPT-23N-XXV and EPT-22W-XXV
Operating/storage range	-95 °C ... +95 °C (-139 ... +203 °F)
Connector color code	Blue

Sensor Tips

EPT-23N-XXX	Stainless steel Diameter 3.2 mm (0.13 in) Length 38 mm (1.5 in)
EPT-22W-XXX (liquid submersible)	Sealed teflon tip Diameter 3 mm (0.12 in) Length 28 mm (1.1 in)
Probe lengths	3 m (10 ft) and 7.6 m (25 ft)
Cable construction	2 mm (0.08 in) diameter Teflon coated cable

EPT - XXX - XXX

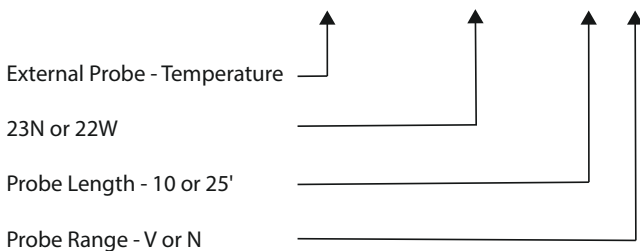

Technical Data

Temperature Range and Accuracy

Internal Sensor

Calibrated measurement range	-25 ... +70 °C (-13 ... +158 °F)
Operating/storage range	-40 ... +85 °C (-40 ... +185 °F) 0 ... 100 %RH non-condensing
Initial accuracy	±0.10 °C over +20 ... +30 °C (±0.18 °F over +68 ... +86 °F) ±0.20 °C over -25 ... +70 °C (±0.36 °F over -13 ... +158 °F)
One year accuracy	±0.15 °C over +20 ... +30 °C (±0.27 °F over +68 ... +86 °F) ±0.25 °C over -25 ... +70 °C (±0.45 °F over -13 ... +158 °F)

External Probes - All Models

"N" Range External Probe

Calibrated measurement range	-25 ... +70 °C (-13 ... +158 °F)
Operating/storage range	-40 ... +95 °C (-40 ... +203 °F)
Initial accuracy ¹⁾	±0.10 °C over +20 ... +30 °C (±0.18 °F over +68 ... +86 °F) ±0.15 °C over -25 ... +70 °C (±0.27 °F over -13 ... +158 °F)
One year accuracy ¹⁾	±0.20 °C over +20 ... +30 °C (±0.36 °F over +68 ... +86 °F) ±0.25 °C over -25 ... +70 °C (±0.45 °F over -13 ... +158 °F)

Resolution	0.02 °C at +25 °C (0.04 °F at +77 °F)
------------	---------------------------------------

"V" Range External Probe

Operating/storage range	-95 ... +95 °C (-139 ... +203 °F)
Initial accuracy ¹⁾	±0.20 °C over -90 ... -40 °C (±0.36 °F over -130 ... -40 °F)
One year accuracy ¹⁾	±0.25 °C over -90 ... -40 °C (±0.45 °F over -130 ... -40 °F)
Resolution	0.02 °C at -80 °C (0.04 °F at -112 °F)
Calibrated measurement range	-90 ... -40 °C (-130 ... -40 °F)

¹⁾ Specification for external channels is for a probe calibrated to the specific channel of the data logger and with the data logger at -25 °C ... +70 °C (-13 °F ... +158 °F)

Product Part Number Legend

Guide for reading the product tables and selecting the most appropriate model for your application.

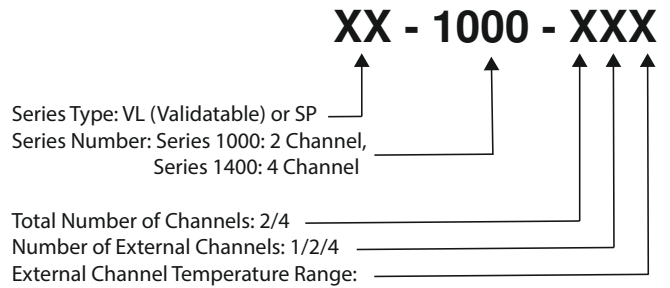

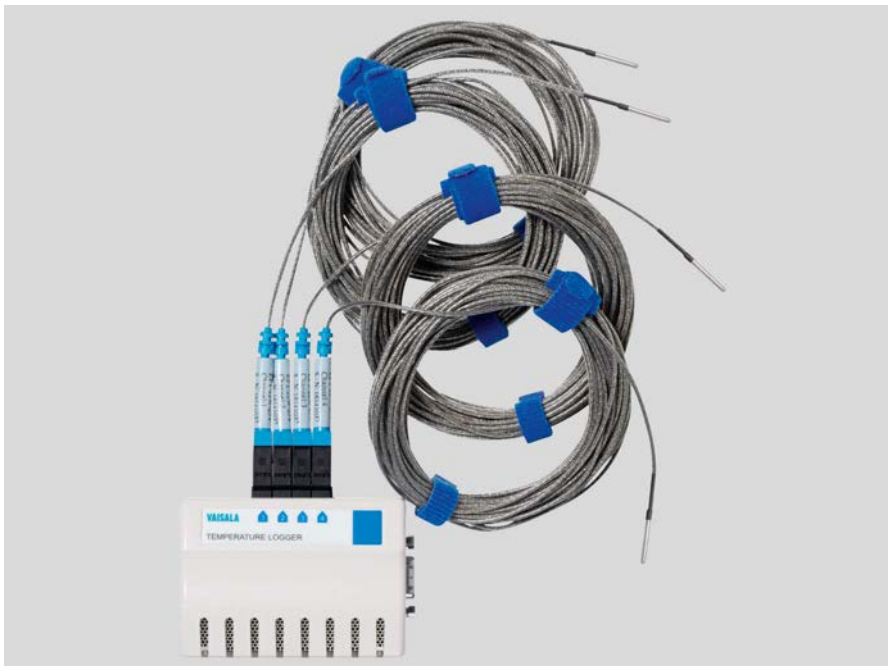

Features

- Industry-leading precision and accuracy
- Real-time monitoring & alarming with viewLinc
- Reliable validation/mapping with vLog
- Easy connectivity to your existing network – wired or wireless
- Validation and continuous monitoring with the same data logger
- Superior alternative to chart recorders and hard-wired systems
- Traceable to SI units through national metrology institutes

Vaisala's multi-application temperature data loggers monitor temperatures in up to four applications with one logger – ultra-low temperature freezers, freezer/refrigerators and incubators.

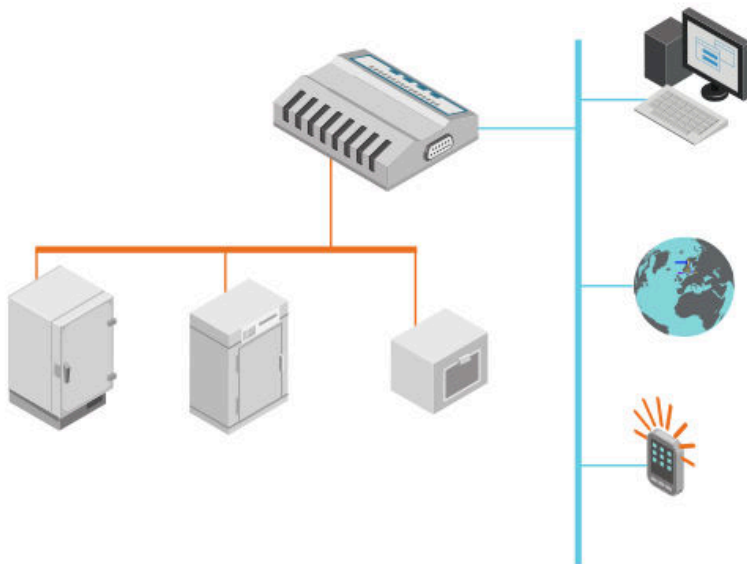

DL1016-1416 data loggers can be used with Vaisala software, either viewLinc or vLog, to download, display, and analyze environmental data.

The viewLinc monitoring system provides 24/7 multi-stage alarm notification, remote, real-time monitoring and gap-free data. The vLog software is a simple solution for validation/mapping applications.

All reports are customizable and can be exported to spreadsheets and PDF to provide records that meet the requirements of 21 CFR Part 11 and Annex 11.

DL1016-1416 data loggers include calibrations traceable to SI units through national metrology institutes.⁴⁾

Choose the DL1016-1416 VL series data logger for GxP-compliant environments and the DL1016-1416 SP series for non-GxP applications.

Model Numbers and Channels

- VL-1016-22V Two external channels for validatable applications
- VL-1416-44V Four external channels for validatable applications
- SP-1016-22V Two external channels
- SP-1416-44V Four external channels

⁴⁾ Measurement results are traceable to the international system of units (SI) through national metrology institutes (NIST USA, MIKES Finland, or equivalent) or ISO/IEC 17025 accredited calibration laboratories.

Technical Data

General

Interfaces	RS-232 serial, USB, Ethernet, WiFi, PoE network interface available
PC software	vLog Graphing & Reporting Software viewLinc for continuous monitoring & alarming OPC Server to add Vaisala recorders to any OPC-compatible monitoring system
Internal clock	Accuracy ±1 min/month 0 ... +50 °C (+32 ... +122 °F)
Power source	Internal 10-year lithium battery (with sample interval of ≥1 min.)
EMC compliance	FCC Part 15 and CE EN 50581:2012 EN 55032:2012/AC:2013 Class B EN 61326-1:2013
RoHS compliance	2011/65/EU

Measurement Performance

Sensor	"V" Range External Probe
Calibrated measurement range	-90 ... +50 °C (-130 ... +122 °F)
Operating range	-95 ... +70 °C (-139 ... +158 °F)
Initial accuracy	±0.25 °C over -90 ... +50 °C (±0.45 °F over -130 ... +122 °F)
One year accuracy	±0.35 °C over -90 ... +50 °C (±0.63 °F over -130 ... +122 °F)
Resolution	0.01 °C at +25 °C (0.02 °F at +77 °F)

Data Logger Operating Environment

Operating temperature	0 ... +50 °C (+32 ... +122 °F)
Operating humidity	0 ... 100 %RH non-condensing
Storage temperature	-40 ... +85 °C (-40 ... +185 °F)
Storage humidity	0 ... 100 %RH non-condensing

Mechanical Specifications

Dimensions	85 × 59 × 26 mm (3.4 × 2.3 × 1 in)
Weight	76 g (2.7 oz)
Mounting	3M Dual Lock™ fasteners Snap-in connector locks provide secure probe connections

Memory

1016 Series	68 600 16-bit samples
1416 Series	101 375 16-bit samples
Memory type	Non-volatile EEPROM
Memory modes and sampling rates	User-selectable rates from once every 10 seconds to once per day (with sample interval of ≥1 min.)

Recording Span: 1016-22V

Sample Interval	Number of Channels Enabled	
	1	2
1 minute	1.5 months	23.8 days
5 minutes	7.6 months	3.8 months
15 minutes	1.9 years	11.5 months
1 hour	7.8 years	3.9 years

Recording Span: 1416-44V

Sample Interval	Number of Channels Enabled			
	1	2	3	4
1 minute	2.3 months	1.1 months	23.5 days	17.6 days
5 minutes	11.3 months	5.6 months	3.7 months	2.8 months
15 minutes	2.8 years	1.4 years	11.3 months	8.5 months
1 hour	11.5 years	5.7 years	3.8 years	2.8 years

Thermistor Probes

Sensor	"V" Range External Probe
Operating Temperature	-95 ... +70 °C (-139 ... +158 °F)
Connector Color Code	Blue
Probe Length	3 m (10 ft) and 7.6 m (25 ft) lengths available
Cable Construction	2 mm (0.07 in) Diameter, Teflon coated cable

Stainless Steel Sensor Tip	
Diameter	3.2 mm (1/8 in)
Length	38 mm (1.5 in)

Sealed Teflon Sensor Tip	
Diameter	3 mm (0.12 in)
Length	28 mm (1.1 in)

Spare Parts and Accessories

Immersion/Dry Probes	
Thermistor V Range probe 25'	235139SP
Thermistor V Range probe 10'	235218SP
Thermistor immersion V Range probe 25'	235140SP
Thermistor immersion V Range probe 10'	235217SP

Temperature Probe Accessories	
Thermal Damping Block	EPT-TDB-2
For use in refrigerators and freezers. Simulates a glycol bottle to reduce alarms generated by opening and closing a door.	

VAISALA

www.vaisala.com



Designed for Controlled Environments

- Extreme temperatures
- Liquid nitrogen (LN₂)
- Ovens
- Sterilization chambers

The Vaisala DL1700 series data loggers provide highly accurate temperature data acquisition and are ideal for demanding environments. The DL1700 data loggers can be used with Vaisala software, either viewLinc or vLog, to download, display, and analyze environmental data.

Applications

- Ideal for extreme temperatures from -240 °C to +1760 °C
- Accepts type J, K, T, E, R and S thermocouples
- No programming or complicated equations required
- Highly accurate replacement for bulky data acquisition systems
- Traceable to SI units through national metrology institutes

The viewLinc monitoring system provides 24/7 multi-stage alarm notification, remote, real-time monitoring and gap-free data. The vLog software is a simple solution for validation/ mapping applications. All reports are customizable and can be exported to spreadsheets and PDF to provide records that meet the requirements of 21 CFR Part 11 and Annex 11.

Easy to use with standard thermocouples, these compact data loggers can offer up to five channels of data in temperatures ranging from -240 °C to +1760 °C.

We offer models for both validated and non-validated applications. Choose the DL1700 VL series for GxP-compliant environments and the DL1700 SP series for non-validated applications.

DL1700 series data loggers include calibrations traceable to SI units through national metrology institutes. ⁵⁾

⁵⁾ Measurement results are traceable to the international system of units (SI) through national metrology institutes (NIST USA, MIKES Finland, or equivalent) or ISO/IEC 17025 accredited calibration laboratories.

Technical Data

General

Interfaces	RS-232 serial, USB, Ethernet, WiFi network interface available
Internal clock	Accuracy: ± 1 min./month at -25 ... +70 °C
Software	viewLinc for Monitoring, Alarming and Reporting vLogVL for Validation/Mapping GxP environments vLogSP for graphing and reporting non-GxP environments OPC Server to add Vaisala loggers to any OPC-compatible monitoring system

Temperature Accuracy

	Temperature Measurement Range	Accuracy at Mid-range	Resolution at Mid-range
Type K	-220 ... +1370 °C (-364 ... +2498 °F)	± 1.3 °C (± 2.3 °F)	0.37 °C (0.67 °F)
Type J	-130 ... +900 °C (-202 ... +1652 °F)	± 1.0 °C (± 1.8 °F)	0.29 °C (0.52 °F)
Type T	-240 ... +350 °C (-400 ... +662 °F)	± 1.2 °C (± 2.2 °F)	0.34 °C (0.61 °F)
Type E	-110 ... +740 °C (-166 ... +1364 °F)	± 0.70 °C (± 1.3 °F)	0.20 °C (0.36 °F)
Type R	-50 ... +1760 °C (-58 ... +3200 °F)	± 4.4 °C (± 7.9 °F)	1.3 °C (2.3 °F)
Type S	-50 ... +1700 °C (-58 ... +3092 °F)	± 5.1 °C (± 9.2 °F)	1.5 °C (2.7 °F)

Operating Environment

Operating temperature	-40 ... +85 °C (-40 ... +185 °F)
Operating humidity	0 ... 100 %RH (non-condensing)
EMC compliance	FCC Part 15 and CE EN 50581:2012 EN 55032:2012/AC:2013 Class B EN 61326-1:2013
RoHS compliance	2011/65/EU

Mechanical Specifications

Dimensions	85 × 59 × 26 mm (3.4 × 2.1 × 1 in)
Weight	60 g (2.7 oz)
Mounting	3M Dual Lock™ fasteners
Power source	Internal 10-year lithium battery (Battery life specified with sample interval of 1 min. or longer)

Cold Junction Temperature Channel

Measurement range	-40 ... +85 °C (-40 ... +185 °F)
Accuracy	± 0.25 °C over +20 ... +30 °C (± 0.45 °F over +68 ... +86 °F) ± 0.35 °C over -25 ... +70 °C (± 0.63 °F over -13 ... +158 °F)

Data Logger Inputs

1700 Model	Number of Channels Enabled		
	Thermocouple	CJT	Total
170-54T	4	1	5

Note: One channel is designated for Cold Junction Temperature (CJT) reference using an on-board precision-tolerance thermistor.

Thermocouple Input Channels

Compatible Thermocouple Types: J, K, T, E, R, S	
Initial Accuracy	
Input range	-7.2 ... +55.4 mV
Resolution	0.016 mV
Initial Accuracy	± 0.042 mV at +25 °C (+77 °F)
Input Impedance: 10M Ω	
Input range	-7.2 ... +55.4 mV
Resolution	0.016 mV
1-Year Accuracy	± 0.055 mV at +25 °C (+77 °F)
Additional Error	
At 3 V/m RF field from 450 MHz ... 580 MHz	± 0.350 mV
At 3 V conducted RF from 3 MHz ... 80 MHz	± 1.0 mV

Memory

Memory type	Non-volatile EEPROM
Data sample capacity	135,165 12-bit samples
Memory modes	User-selectable wrap (FIFO) or stop when memory is full. User-selectable start time.
Sampling rates	User-selectable from once every 10 seconds to once a day. (Battery life specified with sample interval of 1 min. or longer)
Recording span	Recording span depends upon sample interval selected and number of channels enabled.

Spare Parts and Accessories

Thermocouple probe	EPT-22T-20T
Type	T
Conductors	Copper/Constantan
Operating range	-200 ... +200 °C (-328 ... +392 °F)
Length	6.096 m (20 ft)
Error	± 1 °C ... ± 1.5 %



Mid-range Data Loggers

For Temperature, Humidity, and Contact Channel Measurement



Designed for Controlled Environments

- Drug Discovery, R&D
- Early Phase Clinical Trials
- Blood and Tissue Banks
- Hospitals and Pharmacies
- Nutraceutical Manufacturing
- Food and Dietary Supplement Applications
- Aerospace
- Semiconductors
- Museums and Archives

Vaisala's Mid-Range data loggers are designed for early phase drug and device development applications where speed and economy are critical. The MR loggers can be used with Vaisala software to monitor and analyze environmental data and provide presentation-quality records that are easily exported to PDF and spreadsheets.

Simplified Calibration

Easy to install and configure, the MR loggers are calibrated with an abbreviated process that provides reliable accuracy in operating environments between -55 °C to +50 °C. The MR loggers include calibrations traceable to SI units through national metrology institutes.⁶⁾ To ensure cGMP, ISO 9000 and HACCP quality standards. Optional services are available, including extended warranties and onsite calibration.

Easy Configuration

Connectivity options include USB, wireless, and Power over Ethernet with a vNet PoE network interface. When MR loggers are used with vNet PoE device, installation takes minutes. With the vNet device, loggers are automatically identified on your network by the software.

Lean Validation

For applications that require validation, we offer efficient and practical protocols that allow for quick verification of data logger functions. See information on IQOQ documents under "Accessories" on page 3.

Software Options

Whether you need multistage alarming sent via text, email, PC display or dial-out, or to perform a comprehensive mapping study, Vaisala has user-friendly software designed for use in regulated environments, including:

- viewLinc Continuous Monitoring and Alarming
- vLogSP for Validation/Mapping applications

Data Logger Options

Six versions of the MR Loggers are available with up to four channels of Temperature-Only, Temperature + Humidity, or Boolean contact channel for door switches/alarm contact recording:

- DL1000MR - 1 internal temperature channel
- DL1016MR - 2 channel temperature with probes
- DL1016MRB - 2 channel with 1 temperature probe, and 1 contact input
- DL1416MR - 4 channel temperature with probes
- DL1416MRB - 2 channel temperature with probes, and 2 contact inputs
- DL2000MR - 2 internal channels Temperature and RH

⁶⁾ Measurement results are traceable to the International System of units (SI) through national metrology institutes (NIST USA, MIKES Finland, or an equivalent) or ISO/IEC 17025 accredited calibration laboratories.

Technical Data

General

Interfaces	RS-232 serial, Ethernet, USB, WiFi, vNet PoE network interface
Software	<ul style="list-style-type: none"> vLog Validation/Mapping viewLinc Continuous Monitoring & Alarming OPC Server to add Vaisala loggers to any OPC compatible monitoring system
Internal clock accuracy	±1 min. /month 0 to +50 °C (+32 to +122 °F)
Power source	Internal 10-year lithium battery ¹⁾
EMC compliance	FCC Part 15 and CE EN 50581:2012 EN 55032:2012/AC:2013 Class B EN 61326-1:2013
RoHS compliance	2011/65/EU

¹⁾ Battery life specified with sample interval of 1 min. or longer.

Memory

Memory type	Non-volatile EEPROM
Memory mode	User-selectable wrap (FIFO) or stop when memory is full
Sampling rates	User-selectable rates from once every 10 seconds to once per day (Battery life specified with sample interval of 1 min. or longer)
Data Sample Capacity	
DL1000MR	48 100 12-bit samples
DL1016MR/MRB	68 600 16-bit samples
DL1416MR/MRB	101 375 16-bit samples
DL2000MR	122 197 12-bit samples

Mechanical Specifications

Dimensions	85 × 59 × 26 mm (3.4 × 2.3 × 1 in)
Weight	76 g (2.7 oz)
Mounting	3M Dual Lock™ Fasteners Snap-in connector for secure probe connections

Temperature Sensors

Internal sensor type	Precision-tolerance epoxy encapsulated NTC thermistor
Cable construction	2 mm (0.07") Diameter, Teflon coated cable

External Temperature Probes

Sensor tip	Stainless steel
Diameter	3.2 mm (1/8 in)
Length	38 mm (1.5 in)

Probe Cable Lengths

DL1016MR/MRB	3 m (10 ft)
DL1416MR/MRB	7.6 m (25 ft)

Technical Data

DL1000MR Internal Temperature Sensor

Range and Accuracy

Logger operating range	-35 ... +85 °C (-31 ... +185 °F)
Calibrated measurement range	-25 ... +70 °C (-13 ... +158 °F)
Resolution	0.02 at +25 °C (0.04 at +77 °F)
Accuracy over temperature range ¹⁾ at -25 ... +70 °C (-13 ... +122 °F)	±0.5 °C (±0.9 °F)

¹⁾ Initial accuracy includes all known influence quantities present at the time of calibration including calibration uncertainty, mathematical fit, data logger resolution, hysteresis and reproducibility. Not included is any drift related to atypical contamination or misuse.

DL2000MR Internal Temperature/ RH Sensor

Temperature Range and Accuracy

Operating Range	-35 ... +85 °C (-31 ... +185 °F)
Calibrated Measurement Range	-25 ... +70 °C (-13 ... +158 °F)
Accuracy over temperature range ¹⁾ at -25 ... +70 °C (-13 ... +122 °F)	±0.5 °C (±0.9 °F)
Resolution	0.02 °C at +25 °C (0.04 °F at +77 °F)

Relative Humidity Range and Accuracy

Calibrated measurement points	<ul style="list-style-type: none"> 45 %RH at +10 °C (+50 °F) 10 %RH and 80 %RH at +25 °C (+77 °F) 45 %RH at +25 °C (+77 °F) 45 %RH at +45 °C (+113 °F)
Operating Range	0 ... 100 %RH (non-condensing)
Temperature range +20 ... +30 °C (68 ... 86 °F)	10 ... 90 %RH ±2.0 %RH
Temperature range -20 ... +20 °C, +30 ... +70 °C (-4 ... 68 °F, 86 ... 158 °F)	10 ... 90 %RH ±3.0 %RH
Resolution	0.05 %RH
Humidity sensor	Vaisala HUMICAP® 180R
Stability	±2 %RH over 2 years

¹⁾ Initial accuracy includes all known influence quantities present at the time of calibration including calibration uncertainty, mathematical fit, data logger resolution, hysteresis and reproducibility. Not included is any drift related to atypical contamination or misuse.

DL1016/1416MR External Temperature Sensors

Range and Accuracy

Logger operating range	0 ... +50 °C (32 ... +122 °F)
Probe operating range	-95 ... +70 °C (-139 ... +158 °F)
Calibrated measurement range	-55 ... +50 °C (-130 ... +122 °F)
Resolution	0.01 °C at +25 °C (0.02 °F at +77 °F)
Accuracy over temperature range ¹⁾ at -55 ... +50 °C (-67 ... +122 °F)	±0.5 °C (±0.9 °F)

¹⁾ Specification for external channels is for a probe calibrated to the specified channel of the data logger, with the logger at 0 °C to +50 °C (32 °F to +122 °F)

Accessories

Temperature Probe

EPT-TDB: Thermal Dampening Block, for use in refrigerators and freezers. The block simulates a glycol bottle to reduce alarms generated by opening and closing doors.

Boolean Contact Cables

EPT-DS-25 Available cable with magnetic contact switch – 7.6 m (25') for use with MRB loggers.

Validation Documents

VL-VPE-VLNC-43 Express Validation	IQ is eight tests, OQ is eleven tests. Testing includes security testing for users.
-----------------------------------	---



Features

- Eliminates the cost of wiring AC power to each monitored point
- Data loggers can be installed wherever a LAN cable can be run
- Increased data communication protection from power outage because the server room's UPS can provide backup power
- Plug and Play connectivity when using viewLinc Aware function

Wherever reliable network communications and cost are important, more companies are using Power over Ethernet (PoE) devices. Vaisala vNet PoE network interface brings easy connectivity with data loggers at a lower cost than alternative networking devices.

The snap-in design streamlines logger connectivity into a small footprint, eliminating wires between normally separate loggers and PoE devices. When power and data are carried over the same cable, you can also eliminate the cost of installing an AC power source.

vNet PoE integrates VL and SP data loggers without compromising their high accuracy. It brings greater flexibility and simplicity to the deployment of Vaisala Continuous Monitoring system.

The viewLinc Aware function in viewLinc monitoring software allows you to quickly configure data loggers, alone or in batches. Simply place data loggers in a vNet cradle, connect to a Local Area Network, and viewLinc discovers and configures loggers.

vNet PoE interface comes in four models:

- CDL-VNET-P with a fan inside the cradle for data loggers with an internal temperature channel
- CDL-VNET-LP without a fan for data loggers without an internal temperature channel
- CDL-VNET-PC with 15 V output to power external sensors and transmitters; includes internal fan
- CDL-VNET-LPC with 15 V output to power external sensors and transmitters; without internal fan

There is also an option to power the interface with AC. Select the model that fits your application to monitor and record temperature, humidity, CO₂, differential pressure, door switches, and many other parameters.

Technical Data

Measurement Performance

Heating Effect on Measurements

CDL-VNET-P and CDL-VNET-PC	Temperature rise from electronics (important only for loggers with internal sensors): < 0.05 °C as seen by the logger sensor
CDL-VNET-LP and CDL-VNET-LPC	Not to be used for loggers with internal sensors

Operating Environment

Operating temperature	-25 ... +70 °C (-13 ... +158 °F)
Storage temperature	-40 ... +85 °C (-40 ... +185 °F)
Operating humidity	0 ... 90 %RH (non-condensing and not to exceed a mixing ratio of 38.5 g/kg)

Inputs and Outputs

Ethernet connectivity	IEEE 802.3af, 10Base-T
Connectivity cable	Category 5/5e RJ-45 connector 1.83 m (6 ft)
Operating voltage ¹⁾	12-30 VDC Plugs into vNet jack labeled 12 V

Output Voltage

CDL-VNET-P and CDL-VNET-LP	Not available
CDL-VNET-PC and CDL-VNET-LPC	Nominal: 15 VDC Maximum: 350 mW

Power Consumption

CDL-VNET-P and CDL-VNET-LP	Typical: 625 mW Maximum: 700 mW
CDL-VNET-PC and CDL-VNET-LPC	Typical: 900 mW Maximum: 1.35 W

Power Supply ²⁾

North America	12 VDC / 0.5 A max. out 120 VAC in
International	12 VDC / 1.66 A max. out 100-240 VAC in

¹⁾ Optional for use without PoE.
²⁾ Included but not required when using PoE.

Mechanical Specifications

Dimensions (H × W × L)	4.3 × 10.2 × 10.2 cm (1.7 × 4.0 × 4.0 in)
Weight	180 g (6.3 oz)

General

Logger compatibility	v6.00 hardware and higher Includes models VL and SP 1000, 1700, 1200, 1016, 1416, 1400, 2000, 4000
LED indicators	Link, activity, power, logger communications
Device configuration	HTTP Web Interface PC-based configuration wizard
viewLinc Aware	Requires one vNet to be programmed with the viewLinc server IP address. Other vNets on the sub-net will automatically self-configure.
Addressing	DHCP/RARP ARP-Ping Static IP for IP address assignment Net BIOS name
Firmware	Field upgradable firmware

Compliance

Emissions/Immunity	FCC Part 15 and CE EN 50581:2012 EN 55032:2012/AC:2013 Class B EN 61326-1:2013
Conformity	RoHs, 2011/65/EU WEEE

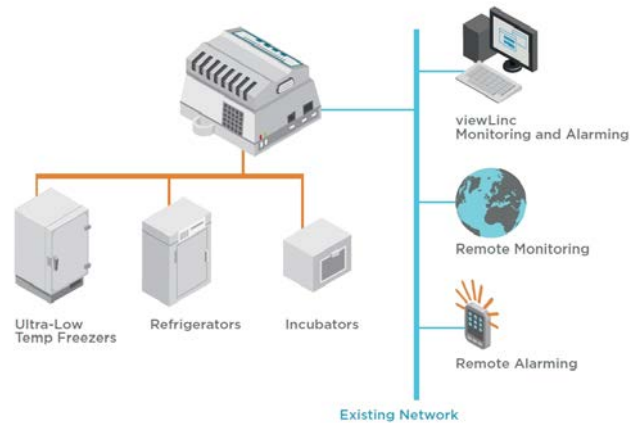

HMT140 Wi-Fi Data Logger

For Multiple Environmental Parameters



Vaisala HMT140 wireless data logger is designed for humidity, temperature, and analog signal monitoring in warehouses, freezer and cryogenic farms, laboratories, blood banks, and many other applications.

Performance

HMT140 incorporates Vaisala HUMICAP® technology to measure relative humidity and temperature accurately and reliably. The HUMICAP® sensor is resistant to dust and most chemicals. Alternatively, HMT140 can connect to Resistance Temperature Detectors (RTDs) or Voltage, Current, and Door Contact sensors, making HMT140 an extremely versatile Wi-Fi data logger. Combining RTD and contact inputs, HMT140 is ideal for monitoring chamber / door contact excursions.

Using Wi-Fi connectivity, HMT140 can connect through any wireless access point. The battery-powered logger can operate for 18 months continuously. Optional local display allows HMT140 to indicate process parameter values and any limit warnings. The LCD display is operated using a power-saving infrared sensor that is motion-activated. When activated, the display indicates the current measurements. All data is logged locally and uploaded to the Vaisala viewLinc monitoring system software at preset intervals and during any parameter excursions.

Autonomous operation with audible and visual alarming (beep and flashing LED) ensures that local alerts are indicated independent of active network or server connection.

The data logger's enclosure is optimized for use in cleanrooms with a surface that is easy to clean and tolerates purifying agents.

Interchangeable Probe

HMT140 data logger uses an easily replaceable relative humidity and temperature probe. This allows for quick recalibration of the data logger. The probe can be adjusted using one of Vaisala's portable meters as a reference.

Available Options

HMT140 data logger is available as wall mounted or with remote probes. For extreme temperature applications or where space is limited, the remote probe is ideal.

Features

- Wi-Fi connectivity to Vaisala viewLinc environmental monitoring system software
- Connectivity provided through existing Wi-Fi Access Points
- Autonomous operation and local alarms ensure alerting capability regardless of network connectivity
- Local data storage provides continuous fail-safe operation
- 18-month battery operation
- Vaisala HUMICAP® technology with humidity sensor HUMICAP® 180R
- Interchangeable relative humidity and temperature probe for easy field calibration
- Accurate and reliable multi-signal measurements
- Resistant to dust and most chemicals
- Traceable to SI units through national metrology institutes ¹⁾
- Ideal for cleanrooms and other life science applications

Options

- Two inputs available: voltage, current, door contact, RTDs, or relative humidity and temperature
- Optional LCD display
- Wall-mounted or with remote probes

¹⁾ Measurement results are traceable to the international system of units (SI) through national metrology institutes (NIST USA, MIKES Finland, or equivalent) or ISO/IEC 17025 accredited calibration laboratories.

Technical Data

HUMICAP® Humidity and Temperature Probe HMP110

Relative Humidity

Measurement range	0 ... 100 %RH
Accuracy (incl. Non-Linearity, Hysteresis and Repeatability):	
At temperature range 0 ... +40 °C (+32 ... +104 °F):	
0 ... 90 %RH	±1.5 %RH
90 ... 100 %RH	±2.5 %RH
At temperature range -40 ... 0 °C, +40 ... +80 °C (-40 ... +32 °F, +104 ... +176 °F):	
0 ... 90 %RH	±3.0 %RH
90 ... 100 %RH	±4.0 %RH
Factory calibration uncertainty at +20 °C (+68 °F)	±1.5 %RH
Humidity sensor	Vaisala HUMICAP® 180R
Stability	±2 %RH over 2 years

Temperature

Measurement range	-40 ... +80 °C (-40 ... +176 °F)
Accuracy over Temperature Range:	
+15 ... +25 °C (+59 ... +77 °F)	±0.2 °C (±0.36 °F)
0 ... +15 °C, +25 ... +40 °C (+32 ... 59 °F, +77 ... +104 °F)	±0.25 °C (±0.45 °F)
-40 ... 0 °C, +40 ... +80 °C (-40 ... +32 °F, +104 ... +176 °F)	±0.4 °C (±0.72 °F)
Temperature sensor	Pt1000 RTD 1/3 Class B IEC 751
HMP110 probe	-40 ... +80 °C (-40 ... +176 °F)
Storage temperature	-50 ... +70 °C (-58 ... +158 °F)

Temperature Probes

Resistive Temperature Input Signals

Temperature sensor	Pt100 RTD / 4 wire, Class A IEC 751
Input impedance	5.1K Ω
Measurement range	-196 ... +90 °C (-320.8 ... +194 °F)
Accuracy over Temperature Range:	
-196 ... -90 °C (-320.8 ... -130 °F)	±2.5 °C (±4.5 °F)
-90 ... -30 °C (-130 ... -22 °F)	±0.75 °C (±1.35 °F)
-30 ... 0 °C (-22 ... +32 °F)	±0.5 °C (±0.9 °F)
0 ... +50 °C (+32 ... +122 °F)	±0.25 °C (±0.45 °F)
+50 ... +90 °C (+122 ... +194 °F)	±0.75 °C (±1.35 °F)

Analog Inputs

Current Input Signals

Current Input Signals	0 ... 22 mA
Resolution	0.67 μA
Accuracy	±0.15 % F.S. at +25 °C (+77 °F)
Input impedance	62 Ω
Overload protection	40 mA

Voltage Input Signals

Voltage Input Signals	0 ... 5 V, 0 ... 10 V
Resolution	0.0034 % F.S.
Accuracy	±0.15 % F.S. at +25 °C (+77 °F)
Input impedance	37K Ω
Overload protection	50 V max.
Isolation	One common per logger

Contact Inputs

Contact Inputs	Open/Closed with magnetic reed switch cable connections (Dry Contact)
----------------	---

Measurement Variants

HMT141	1 Temperature and 1 Humidity Channel
HMT143	2 RTD Temperature Channels
HMT144	2 Voltage Inputs (0 ... 5 VDC)
HMT145	2 Voltage Inputs (0 ... 10 VDC)
HMT146	2 Current Inputs (0 ... 20 mA)
HMT147	2 Door Contacts
HMT148	1 RTD Temperature and 1 Door Contact
HMT14D	1 RTD Temperature and 1 Current Input (0 ... 20 mA)
HMT14E	1 RTD Temperature and 1 Voltage Input (0 ... 5 VDC)
HMT14F	1 RTD Temperature and 1 Voltage Input (0 ... 10 VDC)

Operating Environment

Operating Temperature

Data logger body, no display	-40 ... +60 °C (-40 ... +140 °F)
Data logger body, with display	-20 ... +60 °C (-4 ... +140 °F)
IP rating	IP65
Maximum operating altitude	2000 m (6 500 ft)

General Specifications

Memory	3,060 samples
Sample rate	User selectable (interval: 2 ... 60 minutes)
Display (optional)	128 x 64 resolution full graphics B&W display without backlight

Mechanical Specifications

Weight (with battery/without probe)	300 g (10.6 oz)
Screw terminals	26 AWG ... 20 AWG
HMP110 probe interface	4-pin M8 female panel connector
HMP110 probe cable lengths	3 m, 5 m, and 10 m (9 ft 10 in, 16 ft 5 in, and 32 ft 10 in)
Hermetic Door Switch Sensor cable length	7.6 m (24 ft 11 in)

Material

Data logger housing	PBT plastic
Display window	PC plastic
HMP110 probe body	Stainless steel (AISI 316)
HMP110 probe grid filter	Chrome coated ABS plastic

RTD Temperature Sensor

Sensor tip material	Stainless steel (AISI 316)
Sensor tip length	50.8 mm (2 in)
Sensor tip diameter	4.76 mm (0.19 in)
Cable length	5 m (16 ft 5 in)

Wireless

Networking standards	IEEE 802.11 b/g
Data rates	802.11 b: up to 11 Mbps 802.11 g: up to 54 Mbps
Frequency band	2402 - 2480 MHz
Wi-Fi Security	WEP (128-bit), WPA, WPA2 (Personal)
Output power	+18 dBm (63 mW)
Receiver Sensitivity	-85 dBm typical
Antenna	Onboard whip
Contains	MIC R 201-125765 FCC ID: U30-G2M5477 IC ID: 8169A-G2M5477 NCC ID: CCAF11LP0240T6 CMIIT ID: 2013DJ7129

Standards

Electromagnetic compatibility	EN 61326-1, EN 301 489-1, EN 300 328
Safety	EN 61010-1

Spare Parts and Accessories

HMP110

Humidity and temperature probe	HMP110 ¹⁾
Humidity and temperature replacement probe	HMP110R ¹⁾
Humidity sensor	HUMICAP® 180R
Probe mounting flange	226061
Probe mounting clamps, 10 pcs	226067
Probe cable 3 m	HMT120Z300
Probe cable 5 m	HMT120Z500
Probe cable 10 m	HMT120Z1000
Duct installation kit	215619
Sensor Protection	
Plastic grid filter	DRW010522SP
Plastic grid with membrane filter	DRW010525SP
Stainless steel sintered filter	HM46670SP

Other Accessories

RTD Temperature Probe 5 m	ASM210644SP
Hermetic Door Switch Sensor Kit	236319SP
Thermal Dampener Blocks	236310SP
Four Dual Lock™ Strips (3 in/76 mm)	237217SP

¹⁾ See separate order form



Features

- Achieve time and cost savings by preventing production downtime
- Ensure highly accurate measurements
- Provide certification and mandatory documentation for instrument calibration standards
- Free up staff to focus on primary work assignments
- Enjoy peace of mind with Vaisala-certified calibration expertise and components
- Take advantage of a wide array of available calibrations

Calibrating Vaisala Continuous Monitoring Systems (CMS) on-site helps to maximize reliability and profitability by minimizing costly equipment downtime, removing the need for in-house or factory calibration, and allowing your staff to focus on what is truly important: your business.

Reliable On-site Calibration for Life Science Applications

On-site Calibration Service offers a range of benefits over the conventional options of either shipping equipment back to the manufacturer or calibrating in-house. Reliable on-site calibration minimizes downtime by keeping your monitoring system in place and operational. Certain calibrations require removal of the device from process. For these situations Vaisala offers rental devices and device swap services to ensure continuity of monitoring and gap-free

data. By outsourcing calibration to Vaisala, you remove the need to invest in specialized calibration equipment and training – allowing staff to focus on their primary tasks.

We provide you with a range of single- and multi-point calibration options using application-specific reference instruments, complete with a certificate of NIST traceability. To maintain the high levels of accuracy and optimal performance of your CMS, the system sends a reminder when calibration is due.

Complete Documentation

On-site Calibration Service provides a thorough analysis with comprehensive paper and digital documentation, including a calibration certificate to ensure verification and standards compliance. Calibration reports, data sheets, and calibration labels can be supplied on-site, with digital backup files saved to disk. Our highly accurate calibrations fulfill international standards and make it easy to comply with regulatory requirements.

Technical Data

Single-point Calibration

Temperature

Range	-90 ... +70 °C
Unit Under Test acceptance limits	±1 °C
Calibration points	One point at point of use
Adjustment	Not available
Certificate	Includes as-found/as-left data
Traceability	NIST
Available for the following devices	Vaisala Temperature Data Loggers <ul style="list-style-type: none"> • DL1000 • DL1016 • DL1400 • DL1416 • DL2000 • HMT140
Reference instrument	Vaisala Temperature Data Logger

Temperature for Liquid Nitrogen Applications

Range	-196 °C
Unit Under Test acceptance limits	±3 °C
Calibration points	One point at point of use
Adjustment	Not available
Certificate	Includes as-found/as-left data
Traceability	NIST
Available for the following devices	Vaisala Temperature Data Loggers DL1700
Reference instrument	Vaisala Temperature Data Logger, Fluke 52 Series II

Relative Humidity

Range	Ambient RH (within range of 10 ... 90 %RH) at any temperature within range of +10 ... +45 °C
Unit Under Test acceptance limits	±5 %RH
Calibration points	One point at point of use
Adjustment	Not available
Traceability	NIST
Applicable loggers and transmitters	Vaisala Humidity Data Logger DL2000, HMT140
Reference instrument	Vaisala Humidity Data Logger

Carbon Dioxide

Range	0 ... 20 % at point of use
Unit Under Test acceptance limits	Application dependent
Calibration points	One point at point of use
Adjustment	Not available
Certificate	Includes as-found/as-left data
Traceability	NIST
Available for the following devices	Vaisala Carbon Dioxide Transmitter Series GMT220
Reference instrument	Vaisala GM70

Multi-point Calibration

Temperature

Range	-90 ... +90 °C
Unit Under Test acceptance limits	±0.5 °C
Calibration points	Application-dependent
Adjustment	Available on 3+ point calibrations
Certificate	Includes as-found/as-left data and uncertainties
Traceability	NIST
Available for the following devices	Vaisala Temperature Data Loggers with Probes <ul style="list-style-type: none"> • DL1000 • DL1016 • DL1400 • DL1416 • HMT143 • HMT148
Reference instrument	Ametek ETC159

Relative Humidity

Range	10 ... 90 %RH at ambient temperature
Unit Under Test acceptance limits	Loggers ±3 %RH
Calibration points	Application-dependent
Adjustment	Available on 3+ point calibrations
Certificate	Includes as-found/as-left data and uncertainties
Traceability	NIST
Available for the following devices	Vaisala Relative Humidity Data Loggers HMT141, DL2000
Reference instrument	Vaisala HMT330

Differential Pressure

Range	-15 ... 200 psi
Unit Under Test acceptance limits	Range-dependent
Calibration points	Application-dependent
Adjustment	Available on 3+ point calibrations
Certificate	Includes as-found/as-left data
Traceability	NIST
Available for the following devices	Vaisala Differential Pressure Transmitter Series PDT100
Reference instrument	Fluke Process Calibrator / Pressure Modules

Current and Voltage

Range	0 ... 5 VDC 0 ... 10 VDC 0 ... 20 mA
Unit Under Test acceptance limits	±0.15 %FS at +25 °C
Calibration points	Match Factory Calibration
Adjustment	Yes
Certificate	Includes as-found/as-left data and uncertainties
Traceability	NIST
Available for the following devices	Vaisala Relative Data Loggers HMT140, DL4000, DL2000
Reference instrument	National Instruments PHLe-4141

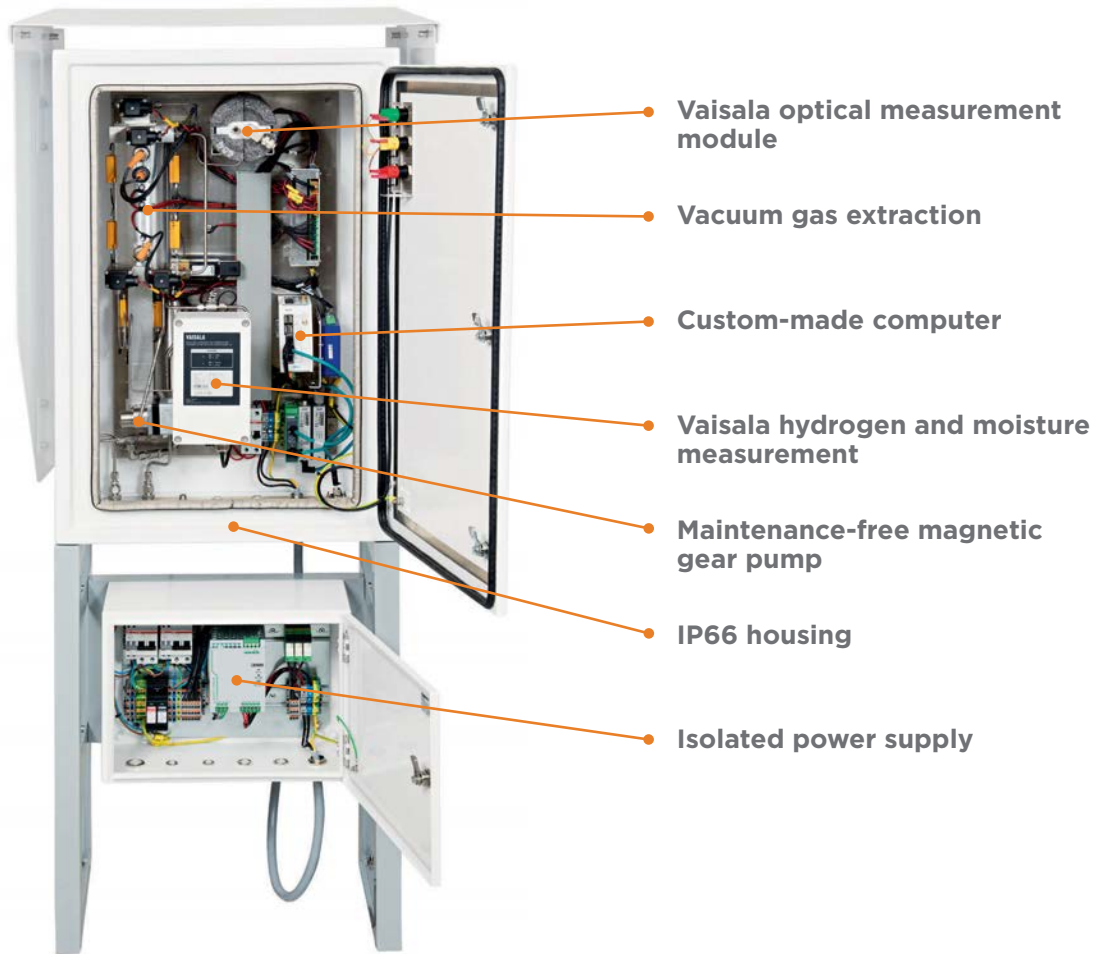

Better Measurement Performance

- Optical IR sensors designed and manufactured in Vaisala cleanrooms
- Spectral scanning provides selective gas measurement
- Vacuum gas extraction independent of oil temperature and pressure
- Unique auto-calibration eliminates long-term drifts – no need to recalibrate

More Robust Design

- Hermetically sealed structure tolerates vacuum and pressure variation
- Stainless steel and aluminum components and piping in contact with oil
- No consumables means no regular maintenance
- Magnetic drive gear pump and high quality valves for durability

Simplified Installation and Operation

- Installation and commissioning in as little as two hours
- Continuous operation with roughly one-hour output interval – no data averaging needed
- Browser-based user interface to easily view and share data, and change settings
- Self-diagnostics with self-recovery after disturbances



Optimus DGA Monitor is the right solution for safeguarding critical transformers in harsh environments

Prevent Power Transformer Failure

There's nothing worse than an unplanned outage, in terms of both lost revenue and the incalculable costs to your reputation and brand. The good news is that over 50 percent of power transformer faults can be detected with the right online monitoring tools, meaning that severe failures can be prevented. But monitors that give false alarms or require regular maintenance can end up wasting considerable amounts of your time and money.

That's why we created the Vaisala Optimus™ DGA Monitor. It provides real-time, trouble free fault gas monitoring for your power transformers – with no false alarms or maintenance.

The two key design drivers have been safety and reliability in demanding operating environments. This is the culmination of decades of listening to customers' needs and researching

existing devices, as well as leveraging our 80 years of experience making sensors and measuring equipment for safety-critical industries and harsh environments.

Dependable Data with No False Alarms

The IR sensor is based on Vaisala core measurement technology and components manufactured in our own cleanroom. Vacuum gas extraction means no data fluctuation due to oil temperature or pressure, while hermetically sealed and protected optics prevent sensor contamination. Moisture is measured directly in the oil with our capacitive thin-film polymer HUMICAP® sensor, which has been used for transformer monitoring for 20 years. Hydrogen is also measured directly in the oil with the same solid-state sensor technology used in the Vaisala MHT410.

Robust Construction

Stainless steel pipes, IP66-rated and temperature-controlled housing, as well as a magnetic drive gear pump and valves mean superb performance and durability – from the arctic to the tropics. What's more, there are no consumables to service or replace.

Smart Design

Vaisala Optimus™ DGA Monitor has a web-based user interface that completely eliminates the need for additional software. The device is designed to be installed in less than two hours – just connect the oil, power, and data connections, and it's ready to go. It can be connected to an existing control and monitoring system via digital communication and relays, or used as a standalone monitoring device. And in case of a disturbance such as a power outage, self-diagnostics allow for self-recovery.

Technical Data

Measured Parameters in Oil

Parameter	Range	Accuracy ^{1) 2)}	Repeatability ²⁾
Methane (CH ₄)	0 ... 10 000 ppm _v	10 ppm or 10 % of reading	10 ppm or 5 % of reading
Ethane (C ₂ H ₆)	0 ... 10 000 ppm _v	10 ppm or 10 % of reading	10 ppm or 5 % of reading ³⁾
Ethylene (C ₂ H ₄)	0 ... 10 000 ppm _v	10 ppm or 10 % of reading	10 ppm or 5 % of reading
Acetylene (C ₂ H ₂)	0 ... 5000 ppm _v	2 ppm or 10 % of reading	1 ppm or 10 % of reading
Carbon monoxide (CO)	0 ... 10 000 ppm _v	10 ppm or 10 % of reading	10 ppm or 5 % of reading
Carbon dioxide (CO ₂)	0 ... 10 000 ppm _v	10 ppm or 10 % of reading	10 ppm or 5 % of reading
Hydrogen (H ₂)	0 ... 5000 ppm _v	25 ppm or 20 % of reading	15 ppm or 10 % of reading
Moisture ⁴⁾ (H ₂ O)	0 ... 100 ppm _w ⁵⁾	±2 ppm ⁶⁾ or ±10 % of reading	Included in accuracy

1) Accuracy specified is the accuracy of the sensors during calibration gas measurements. Accuracy of the gas-in-oil measurement may also be affected by oil properties and other chemical compounds dissolved in oil.

2) Whichever is greater.

3) Repeatability of ethane measurement is specified with averaging of five measurements.

4) Measured as relative saturation (%RS).

5) Upper range limited to saturation.

6) Calculated ppm value is based on average solubility of mineral oils.

Measurement Performance

Measurement cycle duration	1 ... 1.5 h (typical)
Response time (T63)	One measurement cycle ¹⁾
Warm-up time until first measurement data available	Two measurement cycles
Initialization time to full accuracy	Two days
Data storage	At least 10 years
Expected operating life	> 15 years

1) Three cycles for ethane and hydrogen.

Calculated Parameters

Total dissolved combustible gases (TDCG)	Combined total of H ₂ , CO, CH ₄ , C ₂ H ₆ , C ₂ H ₄ , and C ₂ H ₂
Rate of change (ROC)	Available for single gases and TDCG for 24 h, 7 d, and 30 d periods
Gas ratios ¹⁾	Available ratios: <ul style="list-style-type: none"> • CH₄/H₂ • C₂H₂/C₂H₄ • C₂H₂/CH₄ • C₂H₆/C₂H₂ • C₂H₄/C₂H₆ • CO₂/CO

1) Calculated from 24 h average values. See standard IEC 60599.

Operating Environment

Transformer oil type	Mineral oil
Required minimum fire point ¹⁾ of transformer oil	+125 °C (+257 °F)
Transformer oil pressure at oil inlet	Max. 2 bar _{abs} continuous Burst pressure 20 bar _{abs}
Transformer oil temperature at oil inlet	Max. +100 °C (+212 °F)
Ambient humidity range	0 ... 100 %RH, condensing
Ambient temperature range in operation	-40 ... +55 °C (-40 ... +131 °F)
Storage temperature range	-40 ... +60 °C (-40 ... +140 °F)

1) The fire point [of transformer oil] is normally approximately 10 °C [18 °F] higher than the closed flash point. See, for example, Heathcote, Martin J. *The J & P Transformer Book*. 13th ed. Elsevier, 2007.

Power Supply

Operating voltage	100 ... 240 VAC, 50 ... 60 Hz, ±10 %
Overvoltage category	III
Maximum current consumption	10 A
Maximum power consumption	500 W
Typical power consumption at +25 °C (+77 °F)	100 W

Outputs

RS-485 Interface	
Supported protocols	Modbus RTU
Galvanic isolation	2 kV RMS, 1 min
Ethernet Interface	
Supported protocols	DNP3 (Distributed Network Protocol), Modbus TCP, HTTP
Galvanic isolation	4 kV AC (50 Hz, 1 min)
Relay Outputs	
Number of relays	3 pcs, normally open (NO) or normally closed (NC), user selectable
Trigger type	Gas alert with user selectable limits
Max. switching current	6 A (at 250 VAC) 2 A (at 24 VDC) 0.2 A (at 250 VDC)
User Interface	
Interface type	Web based user interface, can be operated with standard web browsers

Mechanical Specifications

Oil fitting	Stainless steel Swagelok® fitting for 10 mm (0.39 in) outer diameter pipe. For 3/8 inch pipe, use adapter SS-600-R-10M.
Max. length of oil pipe to transformer	Max. 10 m (33 ft) with 7 mm (0.28 in) inner diameter pipe Max. 5 m (16 ft) with 4 mm (0.15 in) inner diameter pipe
Material	Marine aluminum (EN AW-5754), stainless steel AISI 316

Type Tests

Category	Standard	Class/Level	Test
EMC compliance	IEC61000-6-5	Class 4 (interface type 4)	Immunity for Power Station and Substation Environments
	IEC61326-1	Industrial	Electrical equipment for measurement, control, and laboratory use - EMC requirements
Environmental	IEC60529	IP66 (equivalent to NEMA 4 rating)	Ingress protection
Safety	IEC/EN61010-1, 3rd edition UL 61010-1:2012 CSA C22.2 No. 61010-1-12	Compliant	Safety requirements for electrical equipment for measurement, control, and laboratory use - Part 1: General requirements

Compliance

CE marking

EMC directive, Low voltage directive, RoHS directive, WEEE directive

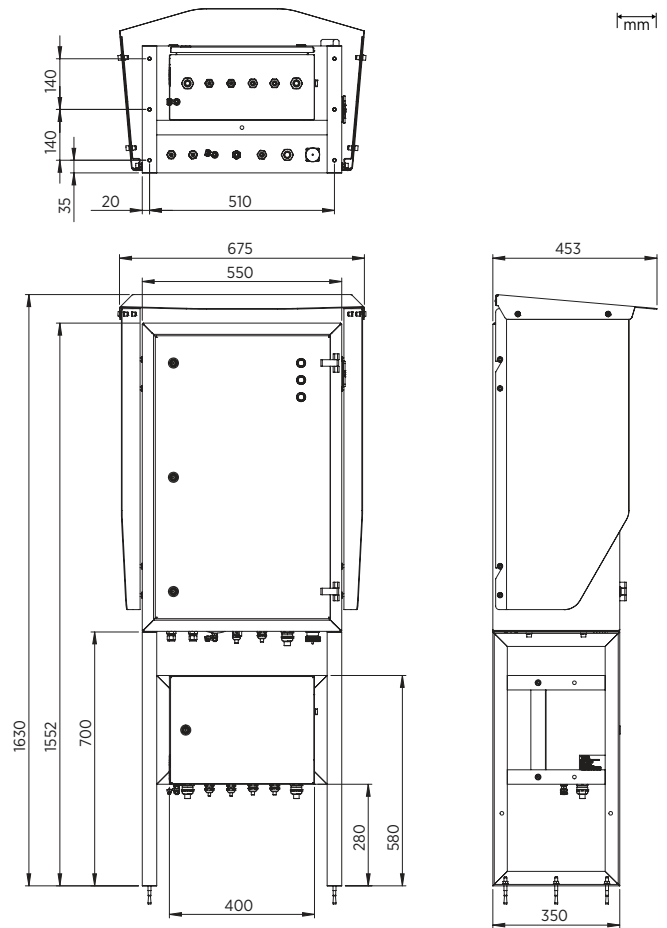

Dimensions

You Can Count on Vaisala

Vaisala has been creating measurement devices for 80 years. Our instruments and systems are used in over 150 countries in industries where failure is not an option, including airports, pharmaceuticals, and power generation. In fact, over 10,000 companies in safety and quality-critical sectors already rely on Vaisala.

Vaisala sensors are so reliable they are used in the harshest places on earth - like arctic, maritime, and tropical environments - and even on Mars.

Power Transformer Monitoring That Works

Vaisala Optimus™ DGA Monitor delivers out-of-the-box performance, eliminates false alarms, and gives you the best long-term stable measurements for the key fault gases used in transformer diagnostics.

VAISALA

www.vaisala.com



MHT410 Moisture, Hydrogen, and Temperature Transmitter

For Online Transformer Condition Monitoring



Features and Benefits

- Measures moisture and hydrogen directly in representative oil
- Compatible with mineral oil, natural ester oil, and synthetic ester oil
- Monitors health of the transformer in real time
- Real-time warning on transformer faults
- Unique probe design, robust and easy to install
- 5-year standard warranty
- Reliable device operation, no false alarms
- Maintenance-free design
- No cross-sensitivity to other gases

Vaisala MHT410 Moisture, Hydrogen, and Temperature Transmitter provides reliable online monitoring of insulating oil in power transformers.

Real-Time Measurement

Vaisala Moisture, Hydrogen, and Temperature Transmitter MHT410 provides an accurate real-time measurement result for critical parameters measured in oil, enabling reliable conclusions on the transformer's condition without delay. With its unique probe design, MHT410 delivers accurate measurement and trend data about the health of the transformer in real time.

Enabling Proactive Maintenance Decisions

All of the transmitter's measured parameters are available through digital and analog outputs, providing information on transformer fault situations and enabling timely, proactive maintenance decisions to minimize expensive service shutdowns and outages.

Robust and Maintenance-Free Design

MHT410 is designed for ease of use in demanding environments. It has undergone extensive testing to ensure it withstands wide temperature changes, vibration and harsh outdoor conditions. The transmitter has no consumables or moving parts that could break, and is encased in an IP66-rated metal housing equipped with a weather shield.

Every unit is individually tested for a pressure of at least 10 bar and also withstands vacuum conditions. Special attention has also been given to EMC tolerance: for example, all electrical connections are isolated. MHT410 can also tolerate short-term power outages.

Dimensions

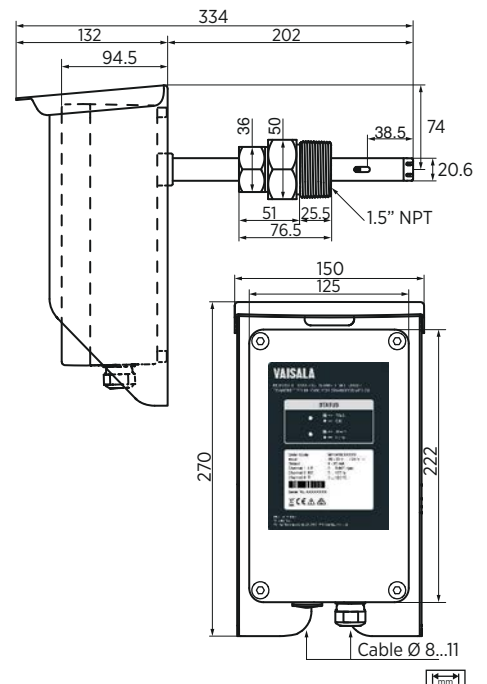

Technical Data

Measurement Performance

Hydrogen

Measurement range (in oil)	0 ... 5000 ppm _v
Accuracy (in oil temperature range -20 ... +60 °C (-4 ... +140 °F)) ¹⁾	±20 % of reading or ±25 ppm _v (whichever is greater)
Repeatability	±10 % of reading or ±15 ppm _v (whichever is greater)
Minimum detection limit	25 ppm _v
Typical long-term stability	3 % of reading / year
Cross sensitivity to other gases	< 2 % (CO ₂ , C ₂ H ₂ , C ₂ H ₄ , CO)
Response time	63 % of full response: 2.5 h (when sensor is not in reference cycle) 90 % of full response: 17 h
Warm-up time	2 h, 12 h for full specification
Sensor	Catalytic palladium-nickel alloy film solid-state sensor

Moisture in Oil

Measurement range (in oil)	0 ... 100 %RS / a _w 0 ... 1
Response time (90 % of full response at +20 °C (+68 °F) in still oil)	10 min
Sensor	HUMICAP® 180L2
Accuracy (including non-linearity, hysteresis, and repeatability):	
0 ... 90 %RS	±2 %RS (a _w ± 0.02)
90 ... 100 %RS	±3 %RS (a _w ± 0.03)

Temperature

Measurement range	-40 ... +120 °C (-40 ... +248 °F) ¹⁾
Accuracy at +20 °C (+68 °F)	±0.2 °C (0.36 °F)
Sensor	Pt1000 RTD Class F0.1 IEC 60751

¹⁾ Note that the temperature range for specified measurement accuracy differs between measurement parameters. Measuring a parameter outside its temperature range does not damage the sensor, but results in reduced accuracy for that parameter.

Inputs And Outputs

Operating voltage	15 ... 30 VDC, 24 VAC (±15 %) (power supply input is galvanically isolated) ¹⁾
-------------------	---

Power consumption	Typical 4 W, maximum 12 W
-------------------	---------------------------

Analog Output (Current)¹⁾

Channels	3 isolated 4 ... 20 mA (loop powering)
External load	Max. 500 Ω
Error status indication in case of device error	3.5 mA default, user-configurable for each channel
mA output accuracy at +20 °C (+68 F)	±0.125 % full scale
Temperature dependence of the analog outputs	±0.006 % / °C full scale

Digital Outputs¹⁾

Interfaces	Isolated RS-485 half-duplex RS-485 (Service Port, non-isolated)
Protocols	Modbus RTU, DNP3, serial ASCII
Screw terminals	Wire size AWG 22-14 Single wire (solid) 1.5 mm ² Stranded wire (flex.) 1.0 mm ² Recommended wire torque 0.4 Nm

¹⁾ Max. isolation voltage 1.5 kV DC.

Mechanical Specifications

Mechanical connection on transmitter	1.5 in NPT (male)
Cable bushing (optional)	M20 × 1.5 for cable diameter 8 ... 11 mm (0.31 ... 0.43 in)
Conduit fitting (optional)	1/2 in NPT
Interface cable (optional, pre-assembled)	5 m (16 ft 5 in), 9.2 mm (0.36 in) outer diameter
Housing material	AlSi 10 Mg
IP rating	IP66
Transmitter weight without cables	4.1 kg (9.04 lb)
Self-diagnostics indication	Status LEDs, analog output, Modbus
Integrated data logging capabilities	Non-volatile memory, up to 44 years' storage with default logging
Individual functional test reports	Calibration test reports for moisture, hydrogen, and temperature; probe leak test report (5 bara nominal)
Factory warranty	5 years

Operating Environment

Oil type	Mineral oil / Natural ester oil / Synthetic ester oil
Operating temperature (electronics)	-40 ... +60 °C (-40 ... +140 °F)
Storage temperature	-40 ... +60 °C (-40 ... +140 °F)
Operating humidity	0 ... 100 %RH, condensing
Pressure tolerance (probe, short-term)	Max. 10 bara
Pressure tolerance (probe, continuous)	Max. 4 bara
Temperature tolerance, sensor head	-40 ... +120 °C (-40 ... +248 °F)
Integrated protection for short power outages	> 3 s
EMC standard EN61326-1, Industrial environment; CISPR22 class B emission limits when DC powered	Fulfills the requirements of IEC 61000-6-5 in the following tests: IEC 61000-4-2, IEC 61000-4-3, IEC 61000-4-4, IEC 61000-4-5, IEC 61000-4-6, IEC 61000-4-8, IEC 61000-4-11, IEC 61000-4-12, IEC 61000-4-16, IEC 61000-4-17.

Display with Relays (External Option)

Pre-configured range for hydrogen	0 ... 5000 ppm _v
Pre-configured alarm relays (user-reconfigurable)	Relay 1 trigger limit 200 ppm _v (hi) Relay 2 trigger limit 1500 ppm _v (hihi)
Input	4 ... 20 mA, loop-powered
Accuracy	0.05 % of span (-10 ... +60 °C (-14 ... +140 °F))
Relays	2 × solid state (SSR) Max. 250 VAC, 150 mA
Display	4-digit red LED, 14.5 mm
Dimensions (H × W × D)	100 × 100 × 57 mm (3.94 × 3.94 × 2.24 in)
Case protection	IP65
Case material and color	ABS plastic, grey
Cable glands	2 × M16×1.5

HPP270 Series Probes

For Hydrogen Peroxide, Humidity, and Temperature Measurement

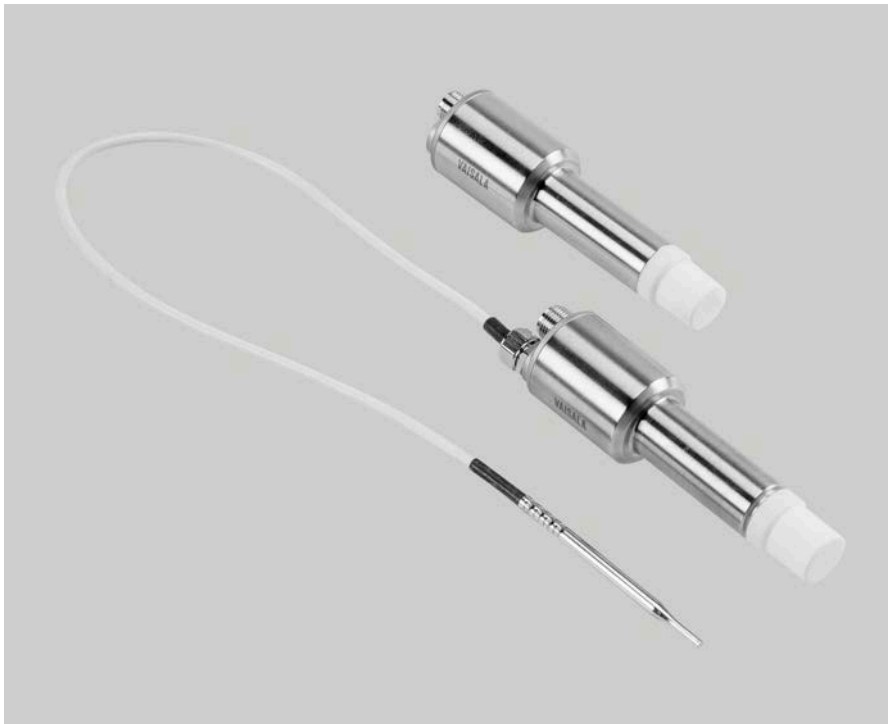

Features

- Basic probe option HPP271 for H₂O₂ vapor concentration measurement
- Advanced probe option HPP272: compact 3-in-1 probe with real-time measurement of H₂O₂ vapor concentration, humidity, and temperature
- Superior long-term stability and repeatability with proprietary PEROXCAP® technology
- Corrosion-resistant stainless steel housing (IP65)
- Traceable calibration certificate
- Standalone probe with digital Modbus RTU over RS-485 or 2 analog outputs
- Compatible with Vaisala Insight PC software and Indigo transmitters

The Vaisala PEROXCAP® Hydrogen Peroxide, Humidity, and Temperature Probe HPP270 series probes HPP271 and HPP272 are designed for demanding hydrogen peroxide bio-decontamination where repeatable, stable, and accurate measurement is essential. HPP270 series probes are suitable for a variety of applications such as isolator, material transfer hatch, and room bio-decontamination.

Up to Three Measurements in One Compact Unit

The advanced HPP272 probe option provides all the parameters you need to measure during bio-decontamination processes: hydrogen peroxide vapor, temperature, and humidity as relative saturation and relative humidity.

Repeatable Measurement for Highly Condensing Environments

Intelligent measurement technology including the chemical purge function helps to maintain accuracy between calibrations in challenging H₂O₂ environments. The purging process involves rapid heating of the sensor to remove possible contamination.

The PEROXCAP sensor used in the HPP270 series probes is warmed, which prevents condensation from forming on the sensor. This provides reliable measurement even in condensing conditions.

Relative Saturation for Comprehensive Humidity Monitoring

Similar to water, H₂O₂ vapor affects the humidity level of the decontaminated air. The advanced HPP272 probe option enables the measurement of relative saturation, which indicates the total humidity level caused by water vapor and H₂O₂ vapor together. This tells you reliably when the bio-decontaminated air starts to condense.

Indigo and Insight Compatible

Vaisala Indigo transmitters provide additional features such as analog and digital outputs, relays, and a smartphone configuration interface. For easy-to-use access to configuration, calibration, and adjustment, the probe can be connected to Vaisala Insight PC software. See www.vaisala.com/indigo and www.vaisala.com/insight.

Traceable Calibration at Vaisala

Every probe and sensor is manufactured and individually calibrated at Vaisala world-class facilities.

Available traceable calibration certificates: 2 points for H₂O₂, 3 points for humidity, 1 point for temperature.

HPP271 Technical Data

Measurement Performance

Hydrogen Peroxide

Sensor	PEROXCAP®
Measurement range	0 ... 2000 ppm
Measurement temperature range	+5 ... +50 °C (+41 ... +122 °F)
Repeatability at +25 °C (+77 °F) up to 500 ppm H ₂ O ₂	±10 ppm
Accuracy (including non-linearity, hysteresis, and repeatability) at +10 ... +25 °C (+50 ... +77 °F), 10 ... 2000 ppm H ₂ O ₂	±10 ppm or 5 % of reading (whichever is greater)
Factory calibration uncertainty, at +25 °C (+77 °F), 500 ppm H ₂ O ₂ ¹	±10 ppm
Response time (T ₆₃)	70 s

Other Parameters

H₂O ppm by volume

¹⁾ Defined as ±2 standard deviation limits. See also calibration certificate.

Inputs and Outputs

Operating voltage	Digital output: 15 ... 30 VDC Analog output: 15 ... 25 VDC
-------------------	---

Current Consumption at +25 °C (+77 °F)

In digital mode	Max. 10 mA
In analog mode	Max. 50 mA
During purge	Max. 250 mA

Digital Output

Interface	RS-485, not isolated; do not use termination on the RS-485 line
Communication protocol	Modbus RTU v.1.02

Analog Output

Outputs	2 × 4 ... 20 mA 3-wire current outputs
Max. load	500 Ω

Operating Environment

Operating temperature	+0 ... +70 °C (+32 ... +158 °F)
Storage temperature	-20 ... +70 °C (-4 ... +158 °F)
Ambient pressure	Normal atmospheric pressure
EMC compliance	EN/IEC 61326-1, Industrial Environment

Mechanical Specifications

IP rating	IP65
Connector	M12/5 male

Materials

Probe body	AISI316L stainless steel
Filter cap	Porous PTFE

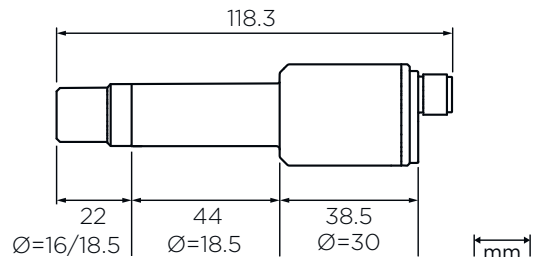

HPP271 Dimensions

Spare Parts and Accessories

USB cable for PC connection ¹⁾	242659
Probe cable with open wires (1.5 m)	254294SP
Probe cable with open wires (3 m)	254295SP
Probe cable with open wires (5 m)	254296SP
Probe cable with open wires (10 m)	254297SP
Filter	DRW246363SP
Gland set for through-wall installation, HPP271	HPP271MOUNTINGSET1
Flange for through-wall installation, HPP271	HPP271MOUNTINGSET2
Wall mount for HPP271 and HPP272	HPP272WALLMOUNT

Transmitters

Indigo transmitters See www.vaisala.com/indigo

¹⁾ Vaisala Insight software for Windows available at www.vaisala.com/insight

HPP272 Technical Data

Measurement Performance

Hydrogen Peroxide

Sensor	PEROXCAP®
Measurement range	0 ... 2000 ppm
Measurement temperature range	+5 ... +50 °C (+41 ... +122 °F)
Repeatability at +25 °C (+77 °F) up to 500 ppm H ₂ O ₂	±10 ppm
Accuracy (including non-linearity, hysteresis, and repeatability) at +10 ... +25 °C (+50 ... +77 °F), 10 ... 2000 ppm H ₂ O ₂	±10 ppm or 5 % of reading (whichever is greater)
Factory calibration uncertainty, at +25 °C (+77 °F), 500 ppm H ₂ O ₂ ¹⁾	±10 ppm
Response time (T ₆₃)	70 s

Relative Saturation

Measurement range	0 ... 100 %RS
Measurement temperature range	+5 ... +50 °C (+41 ... +122 °F)
Repeatability at +25 °C (+77 °F), 500 ppm H ₂ O ₂	±0.5 %RS
Accuracy (including non-linearity, hysteresis, and repeatability) at +25 °C (+77 °F):	±4 %RS
Factory calibration uncertainty, at +25 °C (+77 °F), 500 ppm H ₂ O ₂ ¹⁾	±2 %RS

Relative Humidity

Measurement range	0 ... 100 %RH
Measurement temperature range	+5 ... +70 °C (+41 ... +158 °F)
Accuracy (including non-linearity, hysteresis, and repeatability):	
at 0 ppm H ₂ O ₂ , 0 ... 90 %RH, +25 °C (77 °F)	±1 %RH
over full H ₂ O ₂ and temperature measurement range:	±2 %RH
Response time (T ₆₃)	20 s
Factory calibration uncertainty, at +25 °C (77 °F), 0 ppm H ₂ O ₂ : ¹⁾	
at 0 ... 95 %RH	±1 %RH

Temperature

Sensor	Pt-1000 RTD Class F0.1
Accuracy over temperature range	±0.2 °C (±0.36 °F)

Other Parameters

Absolute H₂O₂ and H₂O, H₂O ppm by volume, water vapor saturation pressure (H₂O and H₂O+H₂O₂), dew point temperature, vapor pressure (H₂O and H₂O₂)

¹⁾ Defined as ±2 standard deviation limits. See also calibration certificate.

Operating Environment

Operating temperature	+0 ... +70 °C (+32 ... +158 °F)
Storage temperature	-20 ... +70 °C (-4 ... +158 °F)
Ambient pressure	Normal atmospheric pressure
EMC compliance	EN/IEC 61326-1, Industrial Environment

Inputs and Outputs

Operating voltage	Digital output: 15 ... 30 VDC Analog output: 15 ... 25 VDC
-------------------	---

Current Consumption at +25 °C (+77 °F)

In digital mode	Max. 10 mA
In analog mode	Max. 50 mA
During purge	Max. 250 mA

Digital Output

Interface	RS-485, not isolated; do not use termination on the RS-485 line
Communication protocol	Modbus RTU v.1.02

Analog Output

Outputs	2 × 4 ... 20 mA 3-wire current outputs
Max. load	500 Ω

Mechanical Specifications

IP rating	IP65
Connector	M12/5 male

Materials

Probe body	AISI316L stainless steel
Filter cap	Porous PTFE
Temperature probe	AISI316L stainless steel
Temperature probe cable	PTFE

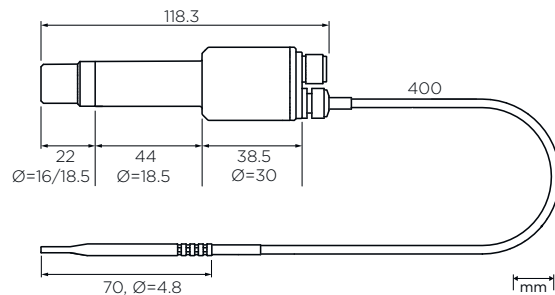

HPP272 Dimensions

Spare Parts and Accessories

USB cable for PC connection ¹⁾	242659
Probe cable with open wires (1.5 m)	254294SP
Probe cable with open wires (3 m)	254295SP
Probe cable with open wires (5 m)	254296SP
Probe cable with open wires (10 m)	254297SP
Filter	DRW246363SP
Gland set for through-wall installation, HPP272	HPP272MOUNTINGSET1
Flange for through-wall installation, HPP272	HPP272MOUNTINGSET2
Wall mount for HPP271 and HPP272	HPP272WALLMOUNT
Indigo transmitters	See www.vaisala.com/indigo

¹⁾ Vaisala Insight software for Windows available at www.vaisala.com/insight



PTU300 Combined Pressure, Humidity, and Temperature Transmitter

For Demanding Applications



Features

- Barometric pressure, humidity, and temperature measurement in one transmitter
- RS-232C serial interface with NMEA protocol for GPS use
- Graphical display and keypad for convenient operation
- Analog outputs, RS-232/485, LAN
- Modbus protocol support (RTU/TCP)
- Traceable to international standards

Vaisala Combined Pressure, Humidity and Temperature Transmitter PTU300 is a unique instrument measuring three parameters simultaneously.

Options

- Available with up to two barometric pressure sensors for added reliability
- Optional universal power supply module
- HMT330MIK installation kit for outdoor use

You can choose from the following probe options: PTU301 for wall mounting for example in laboratories or engine rooms, PTU303 for general use, PTU307 warmed probe for outdoor and demanding meteorology applications, and PTU30T for pressure and temperature measurement only.

Proven Vaisala Sensor Technology

PTU300 incorporates sensors known for their high accuracy and excellent long-term stability: Vaisala BAROCAP® for pressure measurement and Vaisala HUMICAP® for humidity measurement. The temperature sensor is a platinum RTD sensor.

Graphical Display of Measurement Data and Trends for Convenient Operation

PTU300 features a large numerical and graphical display with a multilingual menu and keypad. It allows users to easily monitor operational data, measurement trends, and access measurement history for the past 12 months.

The optional data logger, with real-time clock, makes it possible to generate over four years of measurement history and zoom in on any desired time or time frame.

The display alarm allows any measured parameter to be tracked, with freely configurable low and high limits.

Versatile Outputs and Data Collection

PTU300 comes with a standard RS-232 serial interface. The output format is compatible with major GPS receivers and NMEA-coded messages. An isolated RS-485 interface is available as an option.

PTU300 is also capable of applying the Modbus communication protocol and, together with an appropriate connection option, provides either Modbus RTU (RS-485) or Modbus TCP/IP (Ethernet) communication.

The data logger records data that can be viewed on the local display or transferred to a PC with Microsoft® Windows® software. The transmitter can also be connected to a network with an optional LAN interface, which enables an Ethernet connection. A USB service cable makes it easy to connect PTU300 to a PC via the service port.

Outdoor Installation Kit

Outdoor installation is possible using the optional HMT330MIK installation kit, for applications requiring reliable measurements for meteorological purposes.

Flexible Calibration

Quick, one-point field calibration for humidity is easy using Vaisala Hand-Held Humidity Meter HM70.

With Vaisala Barometric Pressure Transfer Standard PTB330TS, including optional humidity and temperature probe, field check and calibration can be performed for all three parameters.

Applications

- Environmental monitoring in calibration laboratories
- Industrial applications in semiconductor industry, engine testing and maritime sector
- GPS meteorology: estimating precipitable water vapor in the atmosphere, weather stations

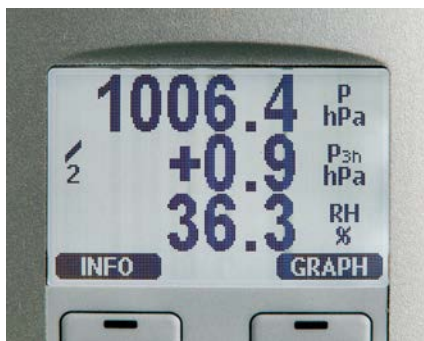

The display also shows the WMO pressure trend ΔP_{3h} and tendency of 0 ... 8.

Model



PTU301 for wall mounting

Dimensions in mm

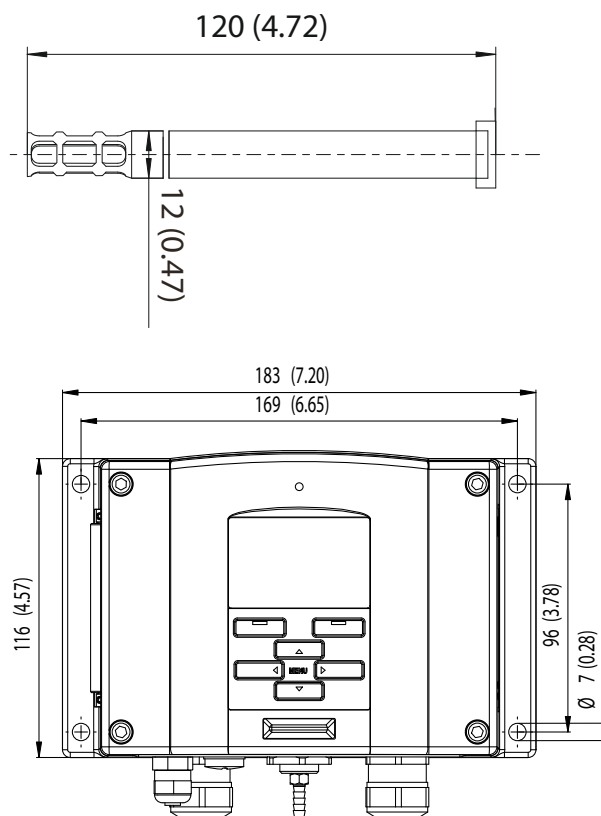

Model

Dimensions in mm

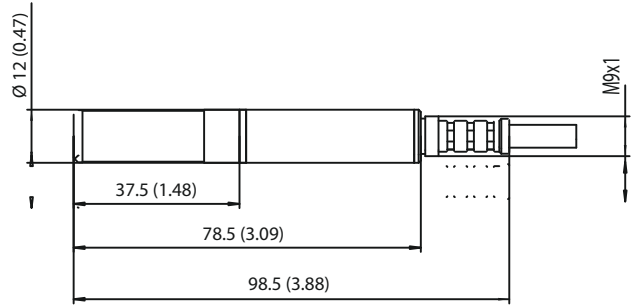

PTU303 probe for outdoor use

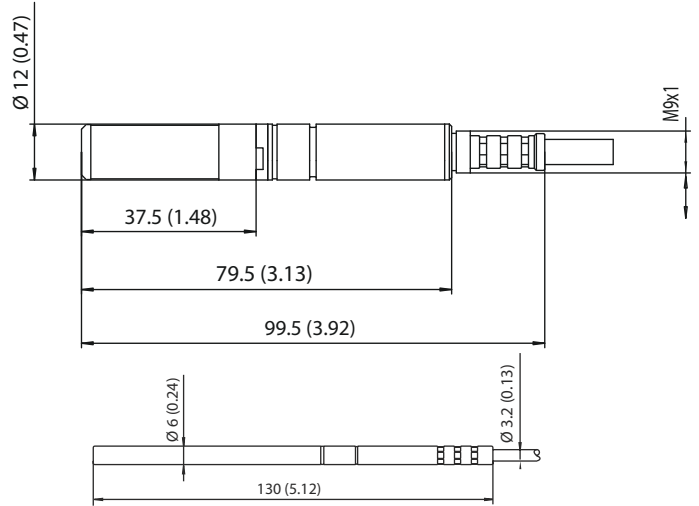

PTU307 warmed probe for demanding meteorological installations

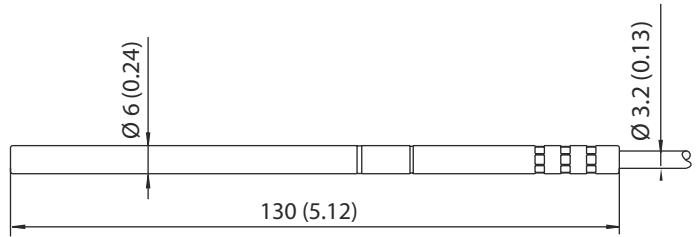

PTU30T for pressure and temperature only measurement

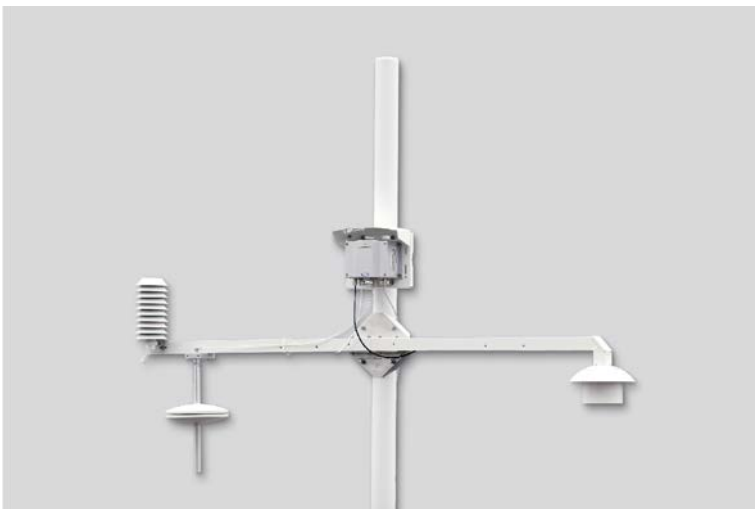

HMT330MIK Meteorological Installation Kit enables PTU307 to be installed outdoors to obtain reliable measurements for meteorological purposes.

Technical Data

Measurement Performance

Barometric Pressure

Pressure range	500 ... 1100 hPa	50 ... 1100 hPa	50 ... 1100 hPa
Accuracy	500 ... 1100 hPa	500 ... 1100 hPa	50 ... 1100 hPa
	Class A	Class B	
Linearity	±0.05 hPa	±0.10 hPa	±0.20 hPa
Hysteresis	±0.03 hPa	±0.03 hPa	±0.08 hPa
Repeatability	±0.03 hPa	±0.03 hPa	±0.08 hPa
Calibration uncertainty	±0.07 hPa	±0.15 hPa	±0.20 hPa
Accuracy at +20 °C / +68 °F	±0.10 hPa	±0.20 hPa	±0.30 hPa
Temperature dependence	±0.1 hPa	±0.1 hPa	±0.3 hPa
Total accuracy (-40 ... +60 °C / -40 ... +140 °F)	±0.15 hPa	±0.25 hPa	±0.45 hPa
Long-term stability/year	±0.1 hPa	±0.1 hPa	±0.2 hPa
Response Time (100 % Response):			
One sensor	2 s	1s	1 s
Pressure units	hPa, mbar, kPa, Pa, inHg, mmH20, mmHg, torr, psia		

Relative Humidity

Measurement range	0 ... 100 %RH	
Accuracy (Including Non-linearity, Hysteresis, and Repeatability):		
At +15 ... +25 °C / +59 ... +77 °F	±1 %RH (0 ... 90 %RH) ±1.7 %RH (90 ... 100 %RH)	
At -20 ... +40 °C / -4 ... +104 °F	±(1.0 + 0.008 x reading) %RH	
At -40 ... +60 °C / -40 ... +140 °F	±(1.5 + 0.015 x reading) %RH	
Factory calibration uncertainty (+20 °C / +68 °F) (Defined as ±2 standard deviation limits. Small variations possible, see also calibration certificate.)	±0.6 %RH (0 ... 40 %RH) ±1.0 %RH (40 ... 97 %RH)	
Sensor for typical applications	Vaisala HUMICAP 180 or 180R	
Sensor for applications with chemical purge/warmed probe	Vaisala HUMICAP 180C or 180RC	
Response Time (90 %) at +20 °C (+68 °F) in Still Air:		
With grid filter	8 s / 17 s ¹⁾	
With grid + steel netting filter	20 s / 50 s ¹⁾	
With sintered filter	40 s / 60 s ¹⁾	

Temperature

Measurement range, housing (barometric pressure measurement limit) ²⁾	-40 ... +60 °C (-40 ... +140 °F)
Measurement range, probes (operational limit when measuring RH or T)	PTU301: -40 ... +60 °C (-40 ... +140 °F) PTU303: -40 ... +80 °C (-40 ... +176 °F) PTU307: -40 ... +180 °C (-40 ... +356 °F) PTU30T: -70 ... +180 °C (-94 ... +356 °F) ³⁾
Accuracy at +20 °C (+68 °F)	PTU301, PTU303, PTU307: ±0.2 °C (±0.4 °F) PTU30T: ±0.1 °C (±0.18 °F)
Temperature units	°C, °F
Temperature sensor	Pt100 RTD Class F0.1 IEC 60751

1) With HUMICAP 180R or 180RC sensor

2) Note that the operational temperature limits of the PTU303, PTU307, and PTU30T probes are higher than for the PTU300 transmitter itself. The transmitter's temperature limit is based on the upper temperature limit for barometric pressure measurement, +60 °C (+140 °F)

3) PTU30T is used for T and P measurements only, RH measurement not in use.

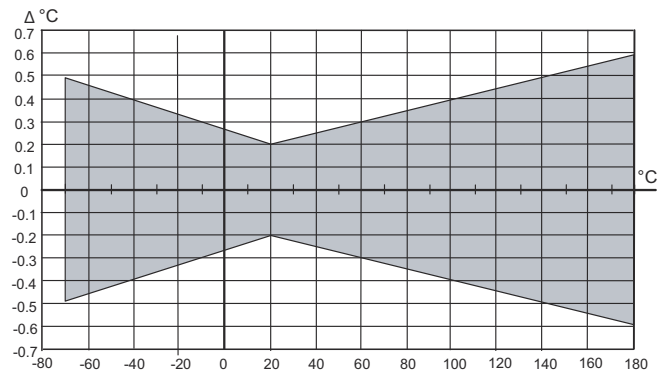

Accuracy over Temperature Range

Operating Environment

Operating temperature	-40 ... +60 °C (-40 ... +140 °F)
Operating temperature with optional display	0 ... +60 °C (+32 ... +140 °F)
Humidity range	Non-condensing
EMC compliance	EN61326-1, Industrial Environment
Note: Transmitter with display test impedance of 40 Ω is used in IEC61000-4-5 (Surge immunity)	

Mechanical Specifications

Cable bushing	M20 x 1.5 for cable diameter 8 ... 11 mm / 0.31 ... 0.43"
Conduit fitting	1/2" NPT
User cable connector (optional)	M12 series 8-pin (male)
Option 1	Female plug with 5 m (16.4 ft) black cable
Option 2	Female plug with screw terminals
Cable diameter, PTU303	6.0 mm
Cable diameter, other probes	5.5 mm
Standard probe cable lengths	2 m, 5 m or 10 m ¹⁾
Housing material	G-AlSi 10 Mg (DIN 1725)
IP rating	IP66 IP65 (NEMA4X) with local display
Weight (depending on selected probe)	1.0 - 3.0 kg / 2.2 - 6.6 lb

1) Additional cable lengths available, please see order form for details.

Optional Data Logger with Real-time Clock

Logged parameters	Max. four with trend/min/max values
Logging interval	10 s (fixed)
Maximum logging period with maximum temporal resolution	4 years 5 months
Logged points	13.7 million points per parameter
Battery lifetime	Min. 5 years

Display

Material	LCD with backlight, graphical trend display of any parameter
Menu languages	English, Chinese, Finnish, French, German, Japanese, Russian, Spanish, Swedish

Inputs and Outputs

Operating voltage	10 ... 35 VDC, 24 VAC ±20 %
With optional power supply module	100 ... 240 VAC, 50/60 Hz
Settling time at power-up (one sensor)	Class A: 4 s Class B: 3 s
Recommended wire size	0.5 mm ² (AWG 20) stranded wires
Digital outputs	RS-232, RS-485 (optional)
Protocols	ASCII commands, Modbus RTU
Service connection	RS-232, USB
Relay outputs (optional)	0.5 A, 250 VAC

Power Consumption at +20 °C (+68 °F) (U_{in} 24 VDC)

RS-232	Max. 28 mA
U _{out} 3 x 0 ... 1 V / 0 ... 5 V / 0 ... 10 V	Max. 33 mA
I _{out} 3 x 0 ... 20 mA	Max. 63 mA
Display and backlight	+20 mA
During chemical purge	Max. +110 mA
During probe heating	+120 mA

External Loads

Current outputs	R _L < 500 Ω
0 ... 1 V output	R _L > 2 kΩ
0 ... 5 V and 0 ... 10 V outputs	R _L > 10 kΩ

Ethernet Interface (Optional)

Supported standards	10BASE-T, 100BASE-TX
Connector	8P8C (RJ45)
IPv4 address assignment	DHCP (automatic), static
Protocols	Telnet, Modbus TCP/IP

Analog Outputs (Optional)

Current output	0 ... 20 mA, 4 ... 20 mA
Voltage output	0 ... 1 V, 0 ... 5 V, 0 ... 10 V
Humidity and Temperature:	
Accuracy of analog outputs at +20 °C (+68 °F)	±0.05 % full scale
Temperature dependence of analog outputs	±0.005 %/°C (0.003 %/°F) full scale
Pressure:	
Accuracy of analog outputs at +20 °C (+68 °F)	±0.30 hPa (500 ... 1100 hPa) ±0.40 hPa (50 ... 1100 hPa)
Accuracy of analog outputs at -40 ... +60 °C / -40 ... +140 °F	±0.60 hPa (500 ... 1100 hPa) ±0.75 hPa (50 ... 1100 hPa)

Spare Parts and Accessories

PC software and cable	215005
USB-RJ45 Serial Connection Cable	219685
Connection cable for HM70	211339
Wall mounting plate (plastic)	214829
Pole installation kit with rain shield	215109
DIN rail installation set	211477
Duct installation kit, PTU303/307	210697
Cable gland and AGRO, PTU303/307	HMP247CG
Solar radiation shield, PTU303/307/30T	DTR502B
Meteorological installation kit	HMT330MIK
Duct installation kit (T probe)	215003

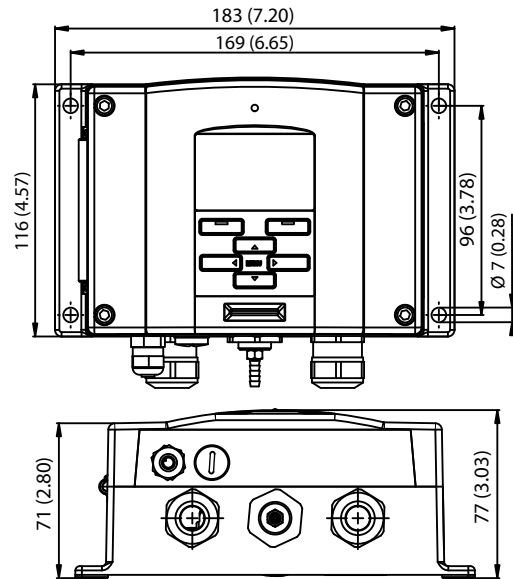

Dimensions in mm (inches)



PTB330 Digital Barometer

For Professional Meteorology, Aviation, and Industrial Users



Features

- Vaisala BAROCAP® sensor
- Accurate measurement
- Excellent long-term stability
- Added reliability through redundancy
- Graphical trend display with 1-year history data
- Height and altitude corrected pressure (QFE, QNH)
- For professional meteorology and aviation, laboratories, demanding industrial applications

Vaisala BAROCAP® Digital Barometer PTB330 is a new-generation barometer, designed for a wide range of high-end atmospheric pressure measurement. The pressure measurement of PTB330 is based on the Vaisala silicon capacitive, absolute pressure sensor - the Vaisala BAROCAP sensor. It provides high measurement accuracy and excellent long-term stability.

Highly Accurate

The PTB330 series is highly accurate. The Class A barometers for the most demanding applications are fine-tuned and calibrated against a high-precision pressure calibrator. Class B barometers are adjusted and calibrated using electronic working standard. All PTB330 barometers come with a traceable factory calibration certificate.

Reliability through Redundancy

According to your choice, PTB330 can incorporate one, two, or three BAROCAP sensors. When two or three sensors are used, the barometer continuously compares the readings of the pressure sensors against one another and reports if they are within the set internal difference criteria. This unique feature provides redundancy in pressure measurement.

Users also get a stable and reliable pressure reading at all times as well as a pre-indication of when to service or recalibrate the barometer.

QNH and QFE

PTB330 can be set to compensate for QNH and QFE pressure used especially in aviation. The QNH represents the pressure reduced to sea level, based on the altitude and temperature of the observation site. The QFE represents the height-corrected pressure of small differences in altitude, for example, the air pressure at the airfield elevation.

Graphical Display

PTB330 features a multilingual, graphical display allowing users to monitor measurement trends. PTB330 updates the graph automatically during measurement and it provides a one-year

measurement history. In addition to instant pressure, PTB330 provides the WMO pressure trend and tendency codes.

Applications

PTB330 can be used successfully for aviation, professional meteorology, and for demanding industrial pressure measurement applications such as accurate laser interferometric measurement and exhaust gas analysis in engine test benches.

Technical Data

Measurement Performance

Barometric Pressure Range 500 ... 1100 hPa

	Class A	Class B
Linearity ¹⁾	±0.05 hPa	±0.10 hPa
Hysteresis ¹⁾	±0.03 hPa	±0.03 hPa
Repeatability ¹⁾	±0.03 hPa	±0.03 hPa
Calibration uncertainty ²⁾	±0.07 hPa	±0.15 hPa
Accuracy at +20 °C (+68 °F) ³⁾	±0.10 hPa	±0.20 hPa

Barometric Pressure Range 50 ... 1100 hPa

	Class B
Linearity ¹⁾	±0.20 hPa
Hysteresis ¹⁾	±0.08 hPa
Repeatability ¹⁾	±0.08 hPa
Calibration uncertainty ²⁾	±0.15 hPa
Accuracy at +20 °C ³⁾	±0.20 hPa

Temperature Dependence ⁴⁾

500 ... 1100 hPa	±0.1 hPa
50 ... 1100 hPa	±0.3 hPa

Total Accuracy -40 ... +60 °C (-40 ... +140 °F)

	Class A	Class B
500 ... 1100 hPa	±0.15 hPa	±0.25 hPa
50 ... 1100 hPa		±0.45 hPa

Long-term Stability

500 ... 1100 hPa	±0.1 hPa/year
50 ... 1100 hPa	±0.1 hPa/year

- 1) Defined as ±2 standard deviation limits of endpoint non-linearity, hysteresis, or repeatability error.
 2) Defined as ±2 standard deviation limits of inaccuracy of the working standard including traceability to international standards.
 3) Defined as the root sum of the squares (RSS) of endpoint non-linearity, hysteresis error, repeatability error, and calibration uncertainty at room temperature.
 4) Defined as ±2 standard deviation limits of temperature dependence over the operating temperature range.

Operating Environment

Pressure range	500 ... 1100 hPa, 50 ... 1100 hPa
Operating temperature	-40 ... +60 °C (-40 ... +140 °F)
Operating temperature with local display	0 ... +60 °C (+32 ... +140 °F)
Compliance	EMC standard EN61326-1:1997 + Am1:1998 + Am2:2001: Industrial Environment

Data Transfer Software

M170 Link Interface software requirements	Microsoft® Windows OS Microsoft® Excel
---	---

Mechanical Specifications

Housing material	G AISi10 Mg (DIN 1725)
Housing classification	IP66 IP65 (NEMA4) with local display
Weight	1 - 1.5 kg (2.2 - 3.3 lbs)

Inputs and Outputs

Supply voltage	10 ... 35 VDC	
Supply voltage sensitivity	Negligible	
Typical power consumption at +20 °C (U _{in} 24 VDC, one pressure sensor)		
RS-232	25 mA	
RS-485	40 mA	
U _{out}	25 mA	
I _{out}	40 mA	
Display and backlight	+20 mA	
Serial I/O	RS-232C, RS-485, RS-422	
Pressure units	hPa, mbar, kPa, Pa inHg, mmH2O, mmHg, torr, psia	
	Class A	Class B
Resolution	0.01 hPa	0.1 hPa
Settling time at startup (one sensor)	4 s	3 s
Response time (one sensor)	2 s	1 s
Acceleration sensitivity	Negligible	
Pressure connector	M5 (10-32) internal thread	
Pressure fitting	Barbed fitting for 1/8 inch I.D. tubing or quick connector with shutoff valve for 1/8 inch hose	
Maximum pressure limit	5000 hPa abs.	

Analog Output (Optional)

Current output	0 ... 20 mA, 4 ... 20 mA	
Voltage output	0 ... 1 V, 0 ... 5 V, 0 ... 10 V	
Accuracy at pressure range	500 ... 1100 hPa	50 ... 1100 hPa
At +20 °C (68 °F)	±0.30 hPa	±0.40 hPa
At -40 ... +60 °C (-40 ... 140 °F)	±0.60 hPa	±0.75 hPa

Accessories

Serial interface cable	19446ZZ
USB-RJ45 serial connection cable	219685
Software interface kit	215005
Wall mounting kit	214829
Outdoor installation kit (weather shield)	215109
Installation kit for pole or pipeline	215108
Power supply module	POWER-1
Temperature compensated analog output module	AOUT-1T
Isolated RS-485 module	RS485-1
DIN Rail Kit	215094

VAISALA

www.vaisala.com



PTB330TS Barometric Pressure Transfer Standard

Take the Lab to the Field



Features

- PTB330 digital barometer for accurate pressure measurement
- Handheld MI70 indicator with a user-friendly, multilingual display
- Service port for MI70 Link software or computer
- Vaisala HUMICAP® humidity and temperature probe HMP155
- Weatherproof transport case

Barometric Pressure Transfer Standard PTB330TS combines a PTB330 digital barometer with a handheld MI70 indicator into a portable unit that can be used as a transfer standard.

Barometer for Portable Use

PTB330TS uses a PTB330 series digital barometer that is housed in a tabletop casing. PTB330TS is designed to be operated using the handheld MI70 indicator. The MI70 indicator also provides the operation power for the barometer. Optional HMP155 probe is available for accurate humidity and temperature measurement.

For Measurements in Industrial and Meteorological Areas

PTB330TS is suitable for reference measurements in industrial and meteorological areas. PTB330TS is housed in a durable and weatherproof

transport case that can be easily carried and shipped. The components of the PTB330TS are placed in a foam interior with accessories and User Guide in the lid organizer. The case includes a shoulder strap.

Available Options

- ISO/IEC 17025 Accredited calibration for PTB330
- HMP155 options: additional temperature probe, manually controlled chemical purge feature
- MI70 Link software and USB or RS-232 cable for downloading measurement data to a computer
- USB service cable for connecting to PTB330 service port

Technical Data

These specifications apply when MI70, PTB330, and HMP155 are used together in PTB330TS. For PTB330 and HMP155 specifications, see the product documentation.

General

Operating temperature	-10 ... +40 °C (+14 ... +104 °F)
Operating humidity	Non-condensing
Maximum pressure limit	5000 hPa abs.
Power supply	Rechargeable NiMH battery pack with AC-adaptor or 4xAA-size alkalines, type IEC LR6
Menu languages	English, Chinese, French, Spanish, German, Russian, Japanese, Swedish, Finnish
Display	LCD with backlight, graphic trend display of any parameter, character height up to 16 mm
Data logging capacity	2700 points
Alarm	Audible alarm function
Compliance	<ul style="list-style-type: none"> EMC Directive (2004/108/EC) Complies with the EMC product family standard EN61326-1 Electrical equipment for measurement control and laboratory use Basic immunity test requirements. Low Voltage Directive (2006/95/EC) ROHS Directive (2002/95/EC)
Operation Time (Using Rechargeable Battery Pack)	
Continuous use with PTB330	11 h typical at +20 °C (+68 °F)
Datalogging use	Up to 30 days

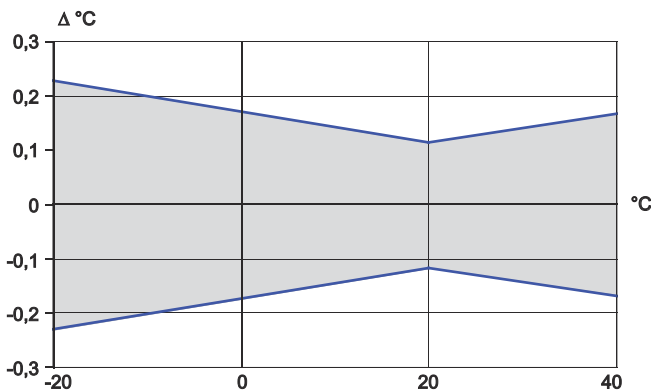

Accuracy of HMP155 temperature measurement over temperature range

Measurement Performance

Barometric Pressure (PTB330)

Measurement range	500 ... 1100 hPa
Linearity ¹⁾	±0.05 hPa
Hysteresis ¹⁾	±0.03 hPa
Repeatability ¹⁾	±0.03 hPa
Calibration uncertainty ²⁾	±0.07 hPa
Accuracy at +20 °C (+68 °F) ³⁾	±0.10 hPa
Temperature dependence ⁴⁾	±0.1 hPa
Total accuracy -40 ... +60 °C (-40 ... +140 °F)	±0.15 hPa
Long-term stability	±0.1 hPa/year
Settling time at startup (one sensor)	4 s
Response time (one sensor)	2 s
Acceleration sensitivity	Negligible

Relative Humidity (HMP155)

Measurement range	0 ... 100 %RH
Accuracy (incl. non-linearity, hysteresis and repeatability)	
at +15 ... +25 °C (+59 ... +77 °F)	±1 %RH (0 ... 90 %RH) ±1.7 %RH (9 ... 100 %RH)
at -10 ... +40 °C (-4 ... 104 °F)	±(1.0 + 0.008 reading) %RH
Factory calibration uncertainty at +20 °C (+68 °F)	±0.6 %RH (0 ... 40 %RH) ⁵⁾ ±1.0 %RH (40 ... 97 %RH) ⁵⁾
Humidity sensor	HUMICAP180R HUMICAP180RC
Response time at +20 °C in still air with a sintered PTFE filter	
63%	20 s
90%	60 s

Temperature (HMP155)

Measurement range	-10 ... +40 °C (+14 ... +104 °F)
Accuracy	
-10 ... +20 °C	±(0.176 - 0.0028 x temperature) °C
+20 ... +40 °C	±(0.07 + 0.0025 x temperature) °C
Temperature sensor	Pt100 RTD Class FO.1 IEC 60751
Response time with additional temperature probe in 3 m/s air flow	
63%	< 20 s
90%	< 35 s

- 1) Defined as ±2 standard deviation limits of endpoint non-linearity, hysteresis, or repeatability error.
- 2) Defined as ±2 standard deviation limits of inaccuracy of the working standard including traceability to NIST.
- 3) Defined as the root sum of the squares (RSS) of endpoint non-linearity, hysteresis error, repeatability error, and calibration uncertainty at room temperature.
- 4) Defined as ±2 standard deviation limits of temperature dependence over the operating temperature range.
- 5) Defined as ±2 standard deviation limits. Small variations possible, see also calibration certificate.

Available Parameters

Pressure parameters	P, P3h, HCP, QFE, QNH
Humidity and temperature parameters	RH, T, Tdf, Td, x, Tw

Inputs and Outputs

MI70 probe ports	2
MI70 data interface	RS-232 (accessible only with MI70 Link software)
PTB330 supply voltage	10 ... 35 VDC (if not powered by MI70)
PTB330 data interface	RS-232C
PTB330 serial I/O connectors	RJ45 (service port) Male 8-pin M12 (user port)
HMP155 data interface	RS-485
HMP155 serial I/O connector	Male 8-pin M12

Mechanical Specifications

PTB330

Housing material	G-AlSi 10 Mg (DIN 1725)
IP rating	IP65
Pressure connector	M5 (10-32) internal thread
Pressure fitting	Barbed fitting for 1/8 inch I.D. tubing or quick connector with shutoff valve for 1/8 inch hose

HMP155

Housing material	PC
IP rating	IP66
Additional T-probe cable length	2 m
Cable material	PUR
Sensor protection	Sintered PTFE

MI70 Measurement Indicator

IP rating	IP54
Housing material	ABS/PC blend

Transport Case

IP rating (when closed)	IP67
Plastic parts	TTX01®, PP+SEBS, POM
Metal parts	Stainless steel AISI303
Interior foam material	Polyethylene and polyether
Weight with all instruments and typical accessories	5.9 kg (13 lbs)
Exterior dimensions (L × W × H)	405 × 330 × 165 mm (15.94 × 12.99 × 6.50 in)

Spare Parts and Accessories

PTB330

MI70 - PTB330 spiral cable	223235SP
USB-RJ45 serial connection cable	219685
Serial connection cable	19446ZZ
Barbed fitting 1/8 in	19498SP
Quick connector 1/8 in	220186
Transport case with interior foams and tabletop casing for PTB330	224068SP

MI70

USB cable for MI70, includes MI70 Link software	219687
MI70 Link software	MI70LINK
MI70 connection cable to HMT330, MMT330, DMT340, HMT100, PTB330	211339
MI70 battery pack variety of AC adapters available	26755

HMP155

HMP155 - MI70 connection cable	221801
Protection set for HMP155 calibration buttons: protective cover, 2 O-rings and protective plug	221318
USB cable for HMP155	221040
Sintered teflon filter + O-ring	219452SP
Humidity sensor	HUMICAP180R
Humidity calibrator	HMK15





Features

- 500 ... 1100 hPa or 50 ... 1100 hPa pressure ranges with serial output
- Different scalings between 500 ... 1100 hPa with analog output
- Electronics housing IP65 protected against sprayed water
- Accurate and stable measurement
- Traceable calibration (certificate included)

Vaisala BAROCAP® Digital Barometer PTB210 is a reliable outdoor barometer for harsh conditions.

For Harsh Environments

PTB210 is ideal for outdoor installations and harsh environments. PTB210 is designed to operate in a wide temperature range, and the electronics housing provides IP65 (NEMA 4) standardized protection against sprayed water.

PTB210 is ideal for use in applications such as weather stations, data buoys and ships, airports, and agrology. They are also an excellent solution for monitoring barometric pressure in industrial equipment such as laser interferometers and engine test benches.

Several Pressure Ranges

PTB210 is designed for various pressure ranges. They are available in two basic configurations:

- Serial output for 500 ... 1100 hPa
- Serial output for 50 ... 1100 hPa
- Analog output with different scalings between 500 ... 1100 hPa

Accurate and Stable Measurement

PTB210 is digitally adjusted and calibrated by using electronic working standards. A higher accuracy barometer, that is fine-tuned and calibrated against a high-precision pressure calibrator, is available for the 500 ... 1100 hPa pressure range.

In addition, PTB210 integrates directly with Vaisala Static Pressure Head Series SPH10/20. This pairing offers accurate measurement in all wind conditions.

Vaisala BAROCAP Technology

PTB210 uses the Vaisala BAROCAP sensor, a silicon capacitive absolute pressure sensor developed by Vaisala for barometric pressure applications. The Vaisala BAROCAP sensor provides excellent hysteresis and repeatability

characteristics and outstanding temperature and long-term stability. PTB210 is delivered with a traceable factory calibration certificate.



PTB210 paired with SPH10 static pressure head

Technical Data

Measurement Performance

Pressure Range

Serial output	500 ... 1100 hPa
	50 ... 1100 hPa
Analog output	500 ... 1100 hPa
	600 ... 1060 hPa
	800 ... 1060 hPa
	900 ... 1100 hPa

Serial Output (Units in hPa), Accuracy

Pressure range	500 ... 1100		50 ... 1100
	Class A	Class B	
Non-linearity ¹⁾	± 0.10	± 0.15	± 0.20
Hysteresis ¹⁾	± 0.05	± 0.05	± 0.10
Repeatability ¹⁾	± 0.05	± 0.05	± 0.10
Calibration uncertainty ²⁾	± 0.07	± 0.15	± 0.20
Accuracy at +20 °C (+68 °F) ³⁾	± 0.15	± 0.20	± 0.35
Temperature dependence ⁴⁾	± 0.20	± 0.20	± 0.40
Total accuracy -40 ... +60 °C (-40 ... +140 °F) ³⁾	± 0.25	± 0.30	± 0.50
Long term stability (hPa/year)	± 0.10	± 0.10	± 0.20

Analog Output, Accuracy

Non-linearity ¹⁾	± 0.20 hPa
Hysteresis ¹⁾	± 0.05 hPa
Repeatability ¹⁾	± 0.05 hPa
Calibration uncertainty ²⁾	± 0.15 hPa
Accuracy at +20 °C (+68 °F) ³⁾	± 0.30 hPa
Temperature dependence ⁴⁾	± 0.50 hPa
Total accuracy -40 ... +60 °C (-40 ... +140 °F) ³⁾	± 0.60 hPa
Long term stability	± 0.10 hPa/year

1) Defined as the ±2 standard deviation limits of end point non-linearity, hysteresis error, or repeatability error.

2) Defined as ±2 standard deviation limits of inaccuracy of the working standard including traceability to international standards.

3) Defined as the root sum of the squares (RSS) of end point non-linearity, hysteresis error, repeatability error, and calibration uncertainty at room temperature.

4) Defined as ±2 standard deviation limits of temperature dependence over the operating temperature range.

Operating Environment

Operating temperature	-40 ... +60 °C (-40 ... +140 °F)
Operating humidity	Non-condensing
EMC compliance	EN61326-1, Generic Environment

Mechanical Specifications

Housing material	PC Plastic
IP rating, electronics	IP65 (NEMA 4)
IP rating, sensor	IP53
Instrument weight	110 g (3.9 oz)
Cable weight	28 g/m (1.0 oz)

Inputs and Outputs

Serial Output

Shutdown	ON/OFF
Settling time at startup	2 s
Serial I/O	RS-232C RS-232C /TTL (optional) RS-485, non isolated (optional)
Parity	None, even, odd
Data bits	7, 8
Stop bits	1, 2
Baud rate	1200, 2400, 4800, 9600, 19200
Response time	1 s
Resolution	0.01 hPa (1 measurement/s) 0.03 hPa (10 measurements/s)
Current consumption, normal mode	< 15 mA (factory setting)
Current consumption, power down mode	< 0.8 mA
Current consumption, shutdown mode	0.2 mA

Analog Output

Outputs	0 ... 5 VDC, 0 ... 2.5 VDC (order specified)
Shutdown	ON/OFF
Response time	500 ms
Resolution	300 µV
Measurement rate	3 measurements/s
Current consumption, normal mode	< 8 mA
Current consumption, shutdown mode	0.2 mA

All Models

Max. pressure	5 000 hPa abs.
Pressure connector	M5 (10-32) internal thread
Pressure fitting	Barbed fitting for 1/8 in I.D. tubing
Supply voltage (reverse polarity protected), with RS-232/TTL output	5 ... 28 VDC
Supply voltage (reverse polarity protected), with RS-485 or analog output	8 ... 18 VDC

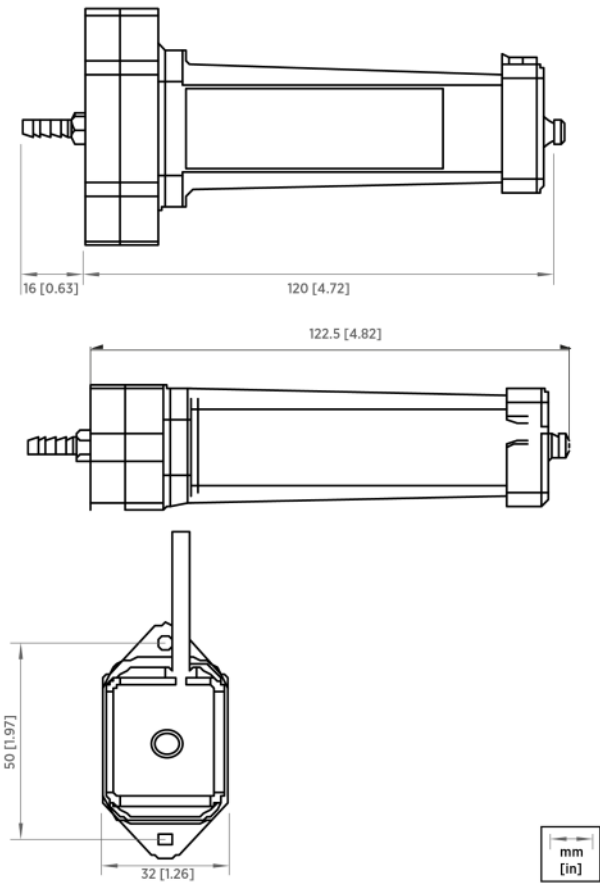



Features

- Vaisala BAROCAP® sensor
- Several pressure ranges
- Accuracy ± 0.3 hPa at $+20$ °C
- Long-term stability
- On/Off control with external trigger
- Output voltage 0 ... 2.5 or 0 ... 5 VDC
- Current consumption less than 4 mA
- Mountable on 35 mm wide DIN rail
- Traceable calibration (certificate included)

Vaisala BAROCAP® Barometer PTB110 is designed both for accurate barometric pressure measurements at room temperature and for general environmental pressure monitoring over a wide temperature range.

Vaisala BAROCAP Technology

PTB110 uses the Vaisala BAROCAP sensor, a silicon capacitive absolute pressure sensor developed by Vaisala for barometric pressure measurement applications. The sensor combines the outstanding elasticity characteristics and mechanical stability of single-crystal silicon with the proven capacitive detection principle.

Applications

PTB110 is suitable for a variety of applications, such as environmental pressure monitoring, data buoys, laser interferometers, and agriculture and hydrology. The compact PTB110 is ideal for data logger applications as it has low power consumption. The external On/Off control is practical when electricity supply is limited.

Accuracy and Stability

The excellent long-term stability of the barometer minimizes or even removes the need for field adjustment in many applications.

Technical Data

Measurement Performance

Pressure range (1 hPa = 1 mbar)	500 ... 1 100 hPa 600 ... 1100 hPa 800 ... 1100 hPa 800 ... 1060 hPa 600 ... 1060 hPa
Resolution	0.1 hPa
Load resistance	10 000 Ω minimum
Load capacitance	47 nF maximum
Settling time to full accuracy after startup	1 s
Response time to full accuracy after a pressure step	500 ms
Acceleration sensitivity	Negligible
Accuracy	
Linearity ¹⁾	±0.25 hPa
Hysteresis ¹⁾	±0.03 hPa
Repeatability ¹⁾	±0.03 hPa
Pressure calibration uncertainty ²⁾	±0.15 hPa
Voltage calibration uncertainty	± 0.7 mV
Frequency calibration uncertainty	± 0.3 Hz
Accuracy at +20 °C (+68 °F) ³⁾	±0.3 hPa
Total Accuracy at	
+15 ... +25 °C (+59 ... +77 °F)	±0.3 hPa
0 ... +40 °C (+32 ... +104 °F)	±0.6 hPa
-20 ... +45 °C (-4 ... +113 °F)	±1.0 hPa
-40 ... +60 °C (-40 ... +140 °F)	±1.5 hPa
Long-term stability	±0.1 hPa / year

- 1) Defined as ±2 standard deviation limits of end-point non-linearity, hysteresis error, or repeatability error.
- 2) Defined as ±2 standard deviation limits of inaccuracy of the working standard including traceability to international standards.
- 3) Defined as the root sum of the squares (RSS) of end-point non-linearity, hysteresis error, repeatability error, and calibration uncertainty at room temperature.

Operating Environment

Operating temperature	-40 ... +60 °C (-40 ... +140 °F)
Storage temperature	-40 ... +60 °C (-40 ... +140 °F)
Operating humidity	Non-condensing
EMC compliance	EN/IEC 61326-1, Electrical equipment for measurement, control and laboratory use - industrial environment

Mechanical Specifications

IP rating	IP32
Dimensions (H × W × D)	97.3 × 68.4 × 28.1 mm (3.83 × 2.69 × 1.10 in)
Weight	90 g (3.2 oz)
Materials	
Housing cover	Plastic ABS/PC blend
Mounting plate	Aluminum

Inputs and Outputs

Supply voltage	10 ... 30 VDC
Supply voltage control	With TTL-level (Transistor-Transistor Logic) trigger
Supply voltage sensitivity	Negligible
Average power consumption	0.10 W at 12 V
Output voltage	0 ... 2.5 VDC 0 ... 5 VDC
Output frequency	500 ... 1100 Hz
Pressure connector	M5 (10 ... 32) internal thread
Pressure fitting	Barbed fitting for 1/8 in
Minimum pressure limit	0 hPa abs
Maximum pressure limit	2000 hPa abs
Electrical connector	A removable connector for 5 wires (AWG 28 ... 16)
Terminals	Pin 1: External triggering Pin 2: Signal ground Pin 3: Supply ground Pin 4: Supply voltage Pin 5: Voltage/Frequency output

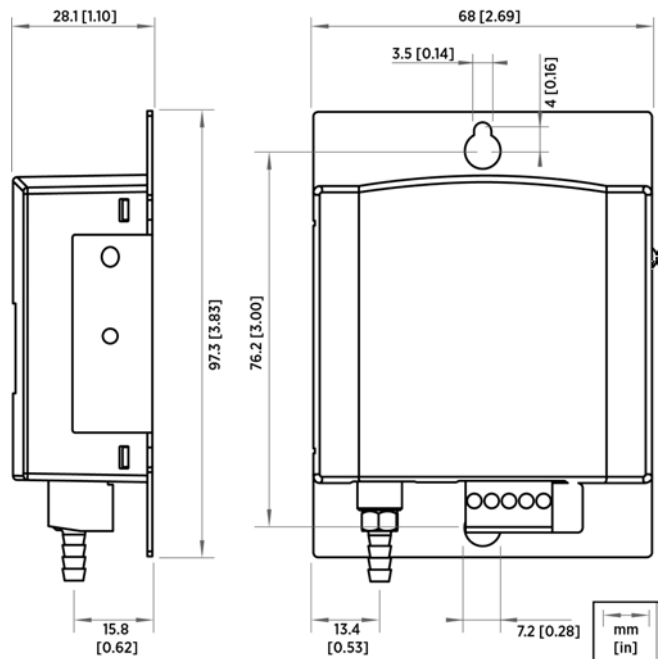

VAISALA

www.vaisala.com

SPH10/20 Static Pressure Heads

For Minimizing Wind Induced Error

SPH10/20 Static Pressure Heads minimize the effects of wind on barometric pressure readings.

Wind induced effects are one of the main sources of error when measuring barometric pressure. Variations due to strong and gusty wind can be overcome by using a static pressure head to reduce the effect of dynamic pressure.

Vaisala Static Pressure Head Series SPH10/20 are designed to minimize the errors caused by wind. Their wind tunnel tested structure is both horizontally and vertically symmetrical. This design ensures reliable barometric pressure measurements in all weather.

Ideal for Outdoor Installations

Vaisala static pressure heads are available in two models: Vaisala Static Pressure Head SPH10 is a basic version, and Vaisala Static Pressure Head SPH20 is a heated version for reliable operation in snowy and icy conditions. The heated SPH20 contains a thermostat that switches on the warming power at temperatures where the risk of icing may occur.

Composed of ultraviolet stabilized PC plastics and offshore aluminum, SPH10/20 static pressure heads are durable and weather resistant.

SPH10/20 protects against rain and condensed water. This prevents capillary condensation of a water column in the pressure channel resulting in a pressure error. The drain holes in the lower plate allow rain and water to flow out. The static pressure heads have internal netting that prevents insects and debris from blocking the pressure channel.

Carefree Maintenance

SPH10/20 static pressure heads are easy to install and disassemble, service, and clean – even at the installation site. Vaisala BAROCAP® Digital Barometer PTB210 can be installed directly on top of SPH10/20 static pressure heads. Other barometers can be connected to the heads with pressure tubing.

SPH10 and SPH20 are a perfect pair for all Vaisala barometers. They ensure an accurate and reliable measurement in all weather conditions.



SPH10/20 is easy to install and connect. In the picture, SPH10 is connected to PTB210.

Features

- Minimizes wind induced error
- Reliable barometric pressure measurement in all weather
- Wind tunnel tested structure
- Easy to clean
- Easy to install

Technical Data

Operating Environment

Operating temperature -60 ... +80 °C (-76... +176 °F)

Mechanical Specifications

Weight	SPH10: 800 g (1.76 lb) SPH20: 1360 g (3.0 lb)
Materials	PC plastic, offshore aluminium
Mounting	With 2 bolts (M6 × 20 mm min.)
Hose connection	Barbed fitting for 4 mm I.D. hose or Rp1/4 thread (parallel)

SPH20 Inputs and Outputs

Electrical connections	M12 connector
Power supply	Factory setting: 12 V Changed connection: 24 V
Power consumption during heating	70 W

Thermostat Switching Temperature

On	+4 °C (±3 °C) +39.2 °F (±4.4 °F)
Off	+13 °C (±3 °C) +55.4 °F (±4.4 °F)

Dimensions in mm (inches)

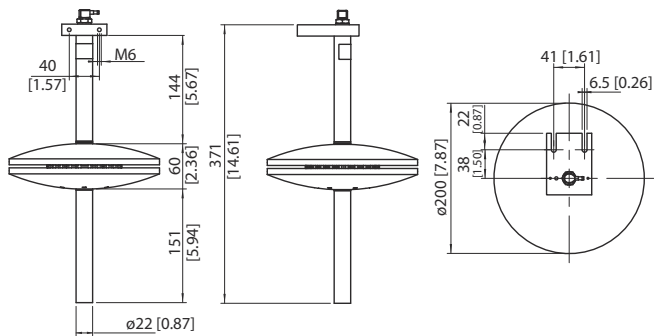

SPH10

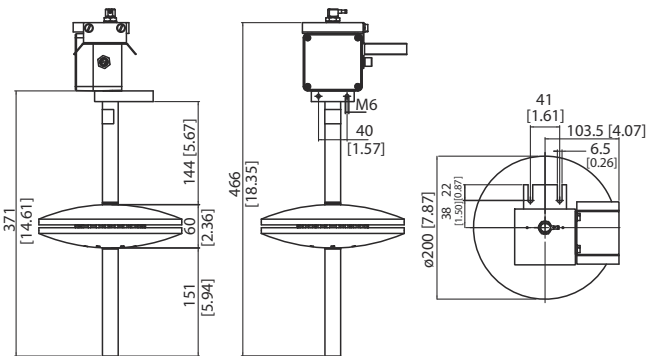

SPH20



Features

- Easy mounting on wall, DIN rail or panel
- 2 pressure ranges (Pa and in H₂O)
- Accessible zero and span adjustment potentiometers
- ¼" brass tubing connections
- LED status indicator
- Specially designed for critical and regulated environments
- Euro style detachable connector
- NIST traceable (certificate included)

Vaisala Differential Pressure Transmitter PDT101 offers precise measurement and control of very low pressures.

Operating Environment

PDT101 is designed especially for demanding life science and high technology cleanroom applications. The transmitter is ideal for incorporating into the Vaisala Veriteq Continuous Monitoring System to measure and monitor the critical environmental parameters as required in regulated environments.

Performance

PDT101 offers high accuracy, sensitivity and stability with accuracy 0.40 % of span providing a highly reliable and repeatable measurement. The sensor

uses a micro-machined, ultra-thin silicon diaphragm which provides inherent sensor repeatability and stability. The sensor enables precise measurement and control in high performance cleanrooms. The PDT101 transmitter is available with voltage output (3-wire) or current output (2-wire).

Zero and span adjustment screws are available on every PDT101 model. Both adjustments are accessible from the front of the unit.

Applications

PDT101 is suitable for high performance cleanroom environments in the life science, semiconductor and electronics industries. As part of a continuous monitoring system, it is highly suitable for regulated environments where continuous, documented and redundant data is a requirement to meet FDA regulations. The compact design is well suited for mounting in a cleanroom or in the adjacent corridor with LED indicator lights for quick and easy power status spot check.

Technical Data

Measurement Performance

Measurement ranges (bidirectional)	±60 Pa ±0.25 in H ₂ O
Accuracy (incl. non-linearity, hysteresis, repeatability and zero/span calibration settings)	0.4 % span
Long-term stability	≤0.5 % span/year
Response time (10 ... 90 %)	250 ms
Warm-up time	15 s
Compensated temperature range	+2 ... +54 °C (+35.6 ... +129.2 °F)
Temperature dependence	±(0.065 Pa + 0.054 % of reading) / °C or ±(0.00015 in H ₂ O + 0.03 % of reading) / °F (reference 21 °C or 70 °F)
Pressure type	Differential, gauge, vacuum and compound
Overpressure	
Proof pressure	1.0 bar
Burst pressure	1.7 bar
Static pressure	1.7 bar
Mounting Position	
Error (zero adjustable)	≤1 %/g (calibration in vertical position is standard)
Adjustments (Front Accessible)	
Zero	±5 % span
Span	±3 % span

Operating Environment

Operating temperature	-18 ... +70 °C (-0.4 ... +158 °F)
Storage temperature	-40 ... +82 °C (-40 ... +179.6 °F)
EMC compliance	EN 61326-1, Basic immunity test requirements
Note: If used in an electromagnetic field of 3 V/m, with narrow frequency area of 80 - 120 Mhz, it is possible that the current output of PDT101 can deviate max. 0.8 % (with accuracy specified 0.4 %)	

Mechanical Specifications

Medium (measured gas)	Clean and dry air, non-conducting and non-corrosive gases
Mounting	Threaded fastener for wall mounting or DIN rail type EN50022
IP rating	IP40
Weight	0.07 kg
Material	
Process connection	Brass
Sensor element	Silicon, aluminium, glass
Case	NEMA type 1 fire-retardant ABS 1 (meets UL94-5VA)

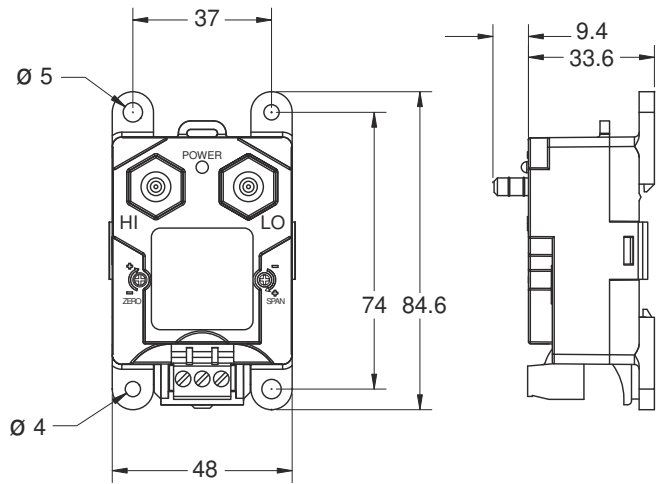

Dimensions in mm

Inputs and Outputs

Process connection	1/4" barbed fittings
Max. loop resistance for 4 ... 20 mA	≤ (Supply voltage - 12V)/0.022 A
Supply current	Max. 20 mA for 4 ... 20 mA output signal
Optical process diagnostics	LED visual indicator
Electrical connection	Euro style pluggable terminal block accepts 12 ... 26 AWG wire (0.13 up to 3.31 mm ²)
Output Signal	
2-wire	4 ... 20 mA
3-wire	0 ... 5 VDC (user selectable 0 ... 10 VDC)
Operating Voltage	
2-wire output 4 ... 20 mA	12 ... 36 VDC
3-wire output 0 ... 5 VDC	11.5 ... 36 VDC
3-wire output 0 ... 10 VDC	14 ... 36 VDC or 24 VAC

Order Information for PDT101

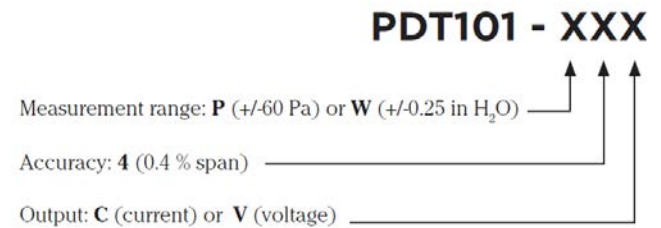



Features

- In-place system calibration and on-line monitoring without disturbing process tubes with optional process valve actuator and test jacks
- Ultrathin profile ideally suited for DIN rail mount reduces installation and calibration costs
- High accuracy, two options; 0.25 % or 0.50 % of span
- Extremely robust MEMS silicon sensor technology provides very high accuracy, sensitivity, stability and durability
- NIST traceable 9 point calibration with certificate
- Front side accessible zero and span adjustment potentiometers

Vaisala Differential Pressure Transmitter PDT102 offers ultra low pressure measurement for cleanroom control and monitoring applications.

Operating Environment

Vaisala Differential Pressure Transmitter PDT102 is a high performance instrument designed primarily for life science and high technology cleanroom applications. The front panel includes zero and span adjustment potentiometers for convenient adjustment. The PDT102 transmitter is ideal for incorporating into the Vaisala Veriteq Continuous Monitoring System to measure and monitor the critical environmental parameters as required in regulated environments.

Performance

PDT102 offers very high accuracy, sensitivity and stability with two options for accuracy, 0.25% or 0.50% of span providing a highly reliable and

repeatable measurement. The sensor uses a micro-machined, ultra-thin silicon diaphragm which provides inherent sensor repeatability and stability. The sensor enables precise measurement and control in high performance cleanrooms. The PDT102 transmitter is available with voltage output (3-wire) or current output (2-wire).

Available Options

Online monitoring of PDT102 is simple using the optional process valve actuator and the front access test jacks. The front access test jacks provide online process reference signal or calibration signal without disconnecting power supply wiring. Measurements can be made using a standard multimeter.

Applications

PDT102 is designed for use in critical monitoring of cleanrooms for pharmaceutical, biotechnology, medical device and semiconductor controlled manufacturing environments.

Technical Data

Measurement Performance

Measurement ranges (bidirectional)	±50 Pa ±0.25 in H ₂ O
Accuracy (incl. non-linearity, hysteresis, repeatability and zero/span calibration settings)	0.25 % span or 0.5 % span, depending on choice
Repeatability for 0.25 % span accuracy	0.03 %
Repeatability for 0.5 % span accuracy	0.05 %
Electrical resolution	1 x 10 ⁻⁴ span
Long-term stability	≤0.5 % span/year
Response time (10 ... 90 %)	250 ms
Warm-up time	15 s
Compensated temperature range	+2 ... +57 °C (+35.6 ... +134.6 °F)
Temperature dependence	±(0.036 Pa + 0.036 % of reading) / °C or ±(0.0001 in H ₂ O + 0.02 % of reading) / °F (reference 21 °C or 70 °F)
Pressure type	Differential, gauge, vacuum and compound
Overpressure	
Proof pressure	0.7 bar
Burst pressure	1.7 bar
Static pressure	1.7 bar
Mounting Position	
Error (zero adjustable)	≤0.25 %
Adjustments (Front Accessible)	
Zero	±5 % span
Span	±3 % span

Operating Environment

Operating temperature	-29 ... +70 °C (-20.2 ... +158 °F)
Storage temperature	-40 ... +82 °C (-40 ... +179.6 °F)
EMC compliance	EN 61326-1, Basic immunity test requirements

Note: If used in an electromagnetic field of 3 V/m, with narrow frequency area of 80 - 120 Mhz, it is possible that the current output of PDT101 can deviate max. 0.3 % (with accuracy specified 0.25 %)

Inputs and Outputs

Process connection	1/8 NPT female according to ANSI/ASME B1.20.1
Operating voltage	12 ... 36 VDC
Max. loop resistance for 4 ... 20 mA	≤ (Supply voltage - 12V)/0.022 A
Electrical connection	Screw terminals, 12 ... 22 AWG (0.33 up to 3.31 mm ²)
Output Signal	
2-wire	4 ... 20 mA
3-wire	0 ... 5 V
Supply Current	
For 0 ... 5 V output	Max. 10 mA
For 4 ... 20 mA output	Max. 20 mA

Mechanical Specifications

Medium (measured gas)	Clean and dry air, non-conducting and non-corrosive gases
Mounting	DIN rail types EN 50022, EN 50035 and EN 50045
IP rating	IP30
Weight	0.16 kg
Material	
Process connection	Brass
Sensor element	Silicon, aluminium, glass
Case	Polycarbonate, glass filled (UL94-V-1)

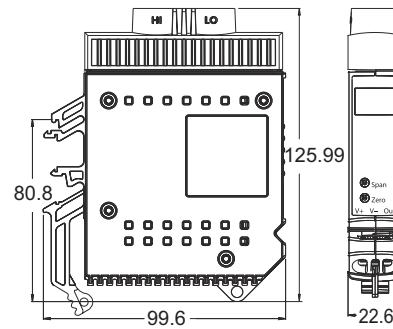

PDT102. Dimensions in mm.

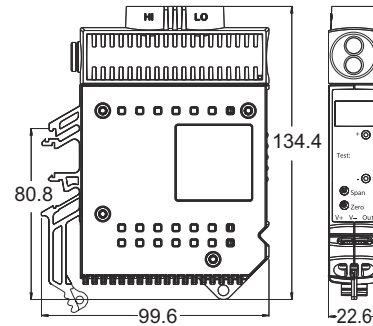

PDT102 with Process Valve Actuator and Test Jacks. Dimensions in mm.

Order Information for PDT101

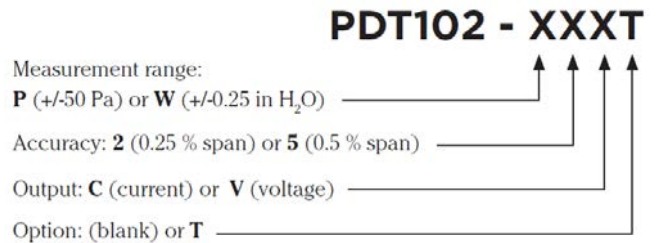



Features

- High-performance wind measurement set
- Long and successful track record in meteorological applications
- Accurate wind speed and direction measurement
- Low measurement starting threshold
- Conical anemometer cups provide excellent linearity
- Heated shaft prevents bearings from freezing

WA15 is based on accurate sensors installed on a crossarm. It is designed for demanding wind measurement applications.

With a proven track record of successful installations, Vaisala Wind Set WA15 has earned its reputation as the industry standard in the wind sensor market.

WA15 consists of Vaisala Anemometer WAA151, Vaisala Wind Vane WAV151, an optional crossarm, a power supply, and cabling.

Anemometer with Excellent Linearity

WAA151 is a fast response, low-threshold anemometer. Three lightweight, conical cups mounted on the cup wheel, provide excellent linearity over the entire operating range, up to 75 m/s (168 mph). A wind-rotated chopper disc attached to the shaft of the cup wheel cuts an infrared light beam 14 times per revolution. This generates a pulse output from the phototransistor.

The output pulse rate is directly proportional to wind speed (for example, 246 Hz = 24.6 m/s (55 mph)). However, for the highest accuracy, the characteristic transfer function must be used to compensate for starting inertia.

Sensitive Wind Vane

WAV151 is a counter-balanced, low-threshold, optoelectronic wind vane. Infrared LEDs and phototransistors are mounted on six orbits on each side of a 6-bit GRAY-coded disc. Turned by the vane, the disc creates changes in the code received by the phototransistors. The output code resolution is $\pm 2.8^\circ$.

Heated Bearings Withstand Cold Weather

Heating elements in the shaft tunnels of both the anemometer and vane keep the bearings above freezing in cold climates.

Complete Package Available

The anemometer and vane are designed to be mounted on Vaisala crossarms. WHP151 power supply provides the operating and heating power needed for WA15. The power supply, as well as the signal and power cables are available as options.

Technical Data

Measurement Performance

Sensor/Transducer type	Cup anemometer/opto-chopper
Observation range	0.4 ... 75 m/s (0.9 ... 168 mph)
Starting threshold ¹⁾	< 0.5 m/s (1.1 mph)
Distance constant	2.0 m (6 ft 7 in)

Transducer Output

0 ... 75 m/s (0 ... 168 mph)	0 ... 750 Hz square wave
Characteristic transfer function	U_f (wind speed) = $0.328 + 0.101 \times R$ (output pulse rate)

Transducer Output Level

($I_{out} < +5$ mA)	High state > $U_{in} -1.5$ V
($I_{out} > -5$ mA)	Low state < 2.0 V

Accuracy Within 0.4 ... 60 m/s (0.9 ... 134 mph)

With characteristic transfer function (standard deviation)	± 0.17 m/s (0.38 mph)
With simple transfer function $U_f = 0.1 \times R$	± 0.5 m/s (1.12 mph) ²⁾

- 1) Measured with the cup wheel in position least favored by flow direction. The optimum position yields $a < 0.35$ m/s (0.8 mph) starting threshold.
2) Typical error vs. speed with the simple transfer function used.

RANGE (m/s)	0-3	3-10	10-17	17-24	24-31	31-37	37-44	44-51	51-58	58-65
ERROR (m/s)	-0.4	-0.3	-0.2	-0.1	0.0	+0.1	+0.2	+0.3	+0.4	+0.5

Inputs and Outputs

Electrical connections	MIL-C-26482 type, 6-wire cable
Cabling	6-wire cable through cross arm
Recommended connector at cable end	SOURIAU UTS6JCI0E6P
Operating power supply	$U_{in} = 9.5 \dots 15.5$ VDC, 20 mA typical
Heating power supply	AC or DC 20 V, 500 mA nominal
Settling time after power-up	< 30 μ s

Operating Environment

Operating temperature ¹⁾	-50 ... +55 °C (-58 ... +131 °F)
Storage temperature	-60 ... +70 °C (-76 ... +158 °F)
Operating humidity	0 ... 100 %RH

- 1) With shaft heating.

Mechanical Specifications

IP rating	IP65
Dimensions (H \times \varnothing)	240 \times 90 mm (9.45 \times 3.54 in)
Swept radius of cup wheel	91 mm (3.58 in)
Weight	570 g (1.26 lb)

Materials

Housing	AlMgSi, gray anodized
Cup	PA, reinforced with carbon fiber

Measurement Performance

Sensor/Transducer type	Optical code disc
Observation range at wind speed 0.4 ... 75 m/s (0.9 ... 168 mph)	0 ... 360°
Starting threshold	< 0.4 m/s (0.9 mph)
Resolution	$\pm 2.8^\circ$
Damping ratio	0.19
Overshoot ratio	0.55
Delay distance	0.4 m (1 ft 4 in)
Accuracy	Better than $\pm 3^\circ$
Output	6-bit parallel GRAY code

Transducer Output Level

($I_{out} < +5$ mA)	High state > $U_{in} -1.5$ V
($I_{out} > -5$ mA)	Low state < 1.5 V

Inputs and Outputs

Electrical connections	MIL-C-26482 type, 10-wire cable
Cabling	10-wire cable through cross arm
Recommended connector at cable end	SOURIAU UTS6JCI2E10P
Operating power supply	$U_{in} = 9.5 \dots 15.5$ VDC, 20 mA typical
Heating power supply	AC or DC 20 V, 500 mA nominal
Settling time after power turn-on	< 100 μ s

Operating Environment

Operating temperature ¹⁾	-50 ... +55 °C (-58 ... +131 °F)
Storage temperature	-60 ... +70 °C (-76 ... +158 °F)
Operating humidity	0 ... 100 %RH

- 1) With shaft heating.

Mechanical Specifications

IP rating	IP65
Dimensions (H \times \varnothing)	300 \times 90 mm (11.81 \times 3.54 in)
Swept radius of vane	172 mm (6.77 in)
Weight	660 g (1.46 lb)

Materials

Housing	AlMgSi, gray anodized
Vane	AISI 12, anodized

WA15 Mechanical Specifications

Dimensions

Junction box	125 \times 80 \times 57 mm (4.92 \times 3.15 \times 2.24 in)
Crossarm length	800 mm (31.50 in)
Mounting to a pole mast with a nominal outside diameter	60 mm (2.36 in)

WA15 Spare Parts and Accessories

Service kit for one WA15/25 sensor (a set of bearings and gasket)	16644WA
Cup assembly WAA151	7150WA
Tail assembly WAV151	6389WA
Sensor board WAA151	1433WA
Sensor board WAV151	1434WA
Attachment hardware for WAA151/252 and WAV151/252	16546WA
Crossarm and serial RS-485 transmitter	WAC155
Component board for WAC155	WAC155CB
Crossarm and termination box	WAC151
16-lead signal cable 10 m for WA15/25, open leads on both ends	ZZ45048
6-lead heating power cable 10 m for WA15/25, open leads on both ends	ZZ45049
Special length 16-lead signal cable for WA15/25, open leads on both ends	ZZ45048SPEC
Special length 6-lead heating power cable for WA15/25, open leads on both ends	ZZ45049SPEC
Sensor cable for WAA151/252 0.8 m (31.5 in) , open lead on one end (6 wires), connector 230118 on another end	ZZ45036
Sensor cable for WAV151/252 0.8 m (31.5 in), open lead on one end (10 wires), connector 230119 on another end	ZZ45037
Special length sensor cable for WAA151/252, open lead in one end (6 wires), connector 230118 on another end	ZZ45036SPEC
Special length sensor cable for WAV151/252, open lead in one end (10 wires), connector 230119 on another end	ZZ45037SPEC
Connector WAA151, WAA252	230118
Connector WAV151, WAV252	230119
Crossarm and analog transmitter	WAT12
Component board for WAT12	16637WA
Power supply for WA15	WHP151
Power board for WHP151 power supply	WA35120

WMT700 Ultrasonic Wind Sensor Series



WMT700 Series has been designed for professional use in meteorology, aviation, maritime, wind energy, and many other applications.

Vaisala WINDCAP® Ultrasonic Wind Sensor WMT700 Series is a robust and reliable ultrasonic anemometer. It measures surface wind, which is one of the key parameters for meteorology and aviation.

WMT700 series meets the updated - WMO-No.8 guide, 7th edition - and ICAO requirements.

Accurate and Maintenance-free

WMT700 series has a durable full steel structure with welded arms, clear North indication, and onepoint, quick bayonet-style mounting. It has no moving parts, and it is resistant to contamination and corrosion.

It measures accurately and produces reliable data in demanding wind conditions and climates without periodic or on-demand maintenance. Self-diagnostics and validation of measurement are standard features. The 60-minute average is available for polar coordinates and vectors.

Measurement Based on Ultrasound

WMT700 series uses ultrasound to determine horizontal wind speed and direction. The measurement is based on transit time, the time it takes for the ultrasound to travel from one transducer to another, depending on the wind speed.

The transit time is measured in both directions for a pair of transducer heads. Using two measurements for each of the three ultrasonic paths at 60° angles to each other, WMT700 computes the wind speed and direction.

The wind measurement is calculated in a way that completely eliminates the effects of altitude, temperature, and humidity.

Standard and Heated Models

WMT700 Series operates with a power supply of 9 ... 36 VDC. For the heated model, an additional heating power supply of 24 ... 36 VDC is required.

Thermostatically controlled heaters in the transducer heads and arms of the heated model prevent build-up of freezing rain or snow. A model with a heated transducer, arms, and body is also available for operation in the harshest and coldest environments.

In addition, accessories are available for mounting and connecting WMT700. To minimize interference from birds, a bird prevention kit is available.

Features

- WMO and ICAO compliant
- Data output rate 4 Hz and 8 Hz
- Stainless steel structure
- Maintenance-free
- Three-transducer layout provides accurate data
- Data format outputs: polar coordinates and vectors
- Fully compensates effects of temperature, humidity, and pressure
- Measurement range up to 90 m/s (201 mph)
- Heating up to 250 W
- IP66 and IP67
- Large transducers provide high ultrasound power
- Optional bird prevention kit
- Wind gust calculated according to the WMO guidelines
- US National Weather Service and the FAA rely on Vaisala WINDCAP® technology



DNV GL TYPE EXAMINATION CERTIFICATE No. TAA00000U5

Technical Data

Wind Speed Measurement Performance

Measurement range	WMT701: 0 ... 40 m/s (89 mph) WMT702: 0 ... 65 m/s (145 mph) WMT703: 0 ... 75 m/s (168 mph) WMT704: 0 ... 90 m/s (201 mph)
Starting threshold	0.01 m/s (0.0223 mph)
Resolution	0.01 m/s (0.0223 mph)
Response time	250 ms
Accuracy	0 ... 75 m/s (168 mph): ±0.1 m/s (0.2 mph) or 2 % of reading, whichever is greater 75 ... 90 m/s (201 mph): ±5 % of reading

Wind Direction Measurement Performance

Observation range	0 ... 360°
Starting threshold	0.1 m/s (0.2 mph)
Resolution	0.01°
Response time	250 ms
Accuracy	±2°

Powering Specifications

Operating voltage	9 ... 36 VDC (absolute max. 40 VDC) ¹⁾
Heating voltage	24 ... 36 VDC (absolute max. 40 VDC) ¹⁾
Heating Power Supply Requirement ²⁾	
Heated transducers	Average 32 W at 24 V Peak 40 W at 24 V
Heated transducers and arms	Average 152 W at 24 V Peak 200 W at 24 V
Heated transducers, arms, and body	Average 252 W at 24 V Peak 350 W at 24 V

¹⁾ In maritime environments, the normal input voltage ranges are: operating voltage 10 ... 30 VDC (-10 ... +30 %) and heating voltage 24 ... 30 VDC (-10 ... +30 %), as defined in the maritime standard IEC 60945.

²⁾ The actual power consumption depends on the temperature.

Messaging Specifications

Readout update interval	4Hz (default) and 8 Hz (optional)
Units available	m/s, knots, mph, km/h, V, mA, Hz
Operating mode	Automatic message or poll mode
Virtual temperature	Celsius degrees

Mechanical Specifications

IP rating	IP66 and IP67
Dimensions (H × W × Ø ¹⁾)	348 × 250 × 285 mm (13.70 × 9.84 × 11.22 in)
Weight	1.8 kg (4.0 lb)
Materials	
Body and arms, mounting kit	Stainless steel AISI 316
Transducers	Silicone
Connector housing surface	Nickel plated brass

¹⁾ Diameter of area covered by transducers.

Accessories

Verifier	WMT70Verifier
Bird cage	WMT70BirdKit
Bird perch	WS425BirdPerch
Cable tightener tool	237888SP
Junction Box with Cable 2 m (connected)	ASM210719SP
Cable 2 m (connector and open leads)	227567SP
Cable 10 m (connector and open leads)	227568SP
Cable 15 m (connector and open leads)	237890SP
RS485 Cable 2 m (connector and open leads)	228259SP
RS485 Cable 10 m (connector and open leads)	228260SP
MAWS cable 10 m	227565SP
AWS520 cable 10 m, shield connected to PE pin	229807SP
AWS520 cable 10 m, shield not connected to PE pin	227566SP
Adapter cable for WS425 serial	227569SP
Adapter cable for WS425 analog frequency output	227570SP
Adapter cable for WS425 analog voltage output	227571SP
Adapter for FIX70	228869
Fix70 (suitable also for inverted mounting)	WMT70FSP
Mounting adapter 60 mm POM	WMT700FIX60-POM
Mounting adapter 60 mm RST	WMT700FIX60-RST
Adapter for FIX30/FIX60	228777
FIX30	WS425Fix30
FIX60	WS425Fix60

Operating Environment

Heating ¹⁾	0 W, 30 W, 150 W, or 250 W
Operating temperature ¹⁾	-10 ... +60 °C (+14 ... +140 °F) -40 °C ... +60 °C (-40 ... +140 °F) -55 ... +70 °C (-67 ... +158 °F)
Storage temperature	-60 ... +80 °C (-76 ... +176 °F)

Compliance	
Wind	ISO16622; MEASNET
EMC	IEC 61000-4-2 ... 6
Environmental	IEC 60068-2-1,2,6/34, 30, 31, 67, 78, IEC 60529 VDA 621-415
Maritime	DNVGL-CG-0339; Lloyd's Register requirements; IEC 60945

¹⁾ For freezing conditions select appropriate combination of heating and temperature ranges.

Digital Outputs

Communication interfaces	COM1: RS-485 COM2: RS-485, RS-422, RS-232, SDI-12
Communication profiles	WMT700, WS425 ASCII, NMEA Standard and Extended (version 0183), SDI-12 (version 1.3), WS425 ASOS, ROSA MES12, customized
Bit rate	300, 1200, 2400, 4800, 9600, 19200, 38400, 57600, or 115200
Available averages	Max. 3600 s

Analog Outputs

Wind speed	Voltage, current, frequency
Wind direction	Voltage, current, potentiometer





Features

- Right parameter combination
- Easy to use and integrate
- Weather parameter hub
- Analog sensors can be added
- Compact, light-weight
- Low power consumption
- mA output suitable for industrial applications
- Cost-effective
- DNV GL Type Examination

Vaisala Weather Transmitter WXT530 is a unique series of sensors with parameter combinations that allow you to choose what is right for your application. WXT530 is a flexible, integrated building block for weather applications. WXT530 series improves your grip on weather.

Flexibility

WXT530 is a series of weather instruments that provides six of the most important weather parameters: air pressure, temperature, humidity, rainfall, wind speed and direction through various combinations. You can select the transmitter with the needed parameter(s) into your weather application, with a large variety of digital communication modes and wide range of voltages. A heated option is available. Low power consumption enables solar panel applications. WXT530 Series focuses on maintenance-free operations in a cost-effective manner.

Integration

The series offers analog input options for additional third party analog sensors. With the help of the built-in analog-to-digital converters, you can turn WXT530 into a small, cost-effective weather parameter hub.

Additional parameters include solar radiation and external temperature sensor. Further, the analog mA output for wind speed and wind direction enables a wide variety of industrial applications. WXT530 exceeds IEC60945 maritime standard.

Solid Performance

WXT530 Series has a unique Vaisala solid state sensor technology. To measure wind, Vaisala WINDCAP® ultrasonic wind sensors are applied to determine horizontal wind speed and direction. Barometric pressure, temperature, and humidity measurements are combined in the PTU module using capacitive measurement for each parameter. This module is easy to change without any contact with the sensors. The precipitation

measurement is based on the unique acoustic Vaisala RAINCAP® Sensor without flooding, clogging, wetting, and evaporation losses.



DNV GL TYPE EXAMINATION CERTIFICATE No. TAA00000VF

Technical Data

Available options	Rain	Wind speed, Wind direction	Pressure, Temperature, Relative Humidity	Analog inputs	2 × mA outputs
WXT531	✓				
WXT532		✓			✓
WXT533	✓	✓			
WXT534			✓		
WXT535	✓		✓		
WXT536	✓	✓	✓	✓	

Barometric Pressure Measurement Performance

Observation range	600 ... 1100 hPa
Accuracy (for sensor element)	±0.5 hPa at 0 ... +30 °C (+32 ... +86 °F) ±1 hPa at -52 ... +60 °C (-60 ... +140 °F)
Output resolution	0.1 hPa / 10 Pa / 0.001 bar / 0.1 mmHg / 0.01 inHg

Air Temperature Measurement Performance

Observation range	-52 ... +60 °C (-60 ... +140 °F)
Accuracy (for sensor element) at +20 °C (+68 °F)	±0.3 °C (±0.5 °F)
Output resolution	0.1 °C (0.1 °F)

Relative Humidity Measurement Performance

Observation range	0 ... 100 %RH
Accuracy (for sensor element)	±3 %RH at 0 ... 90 %RH ±5 %RH at 90 ... 100 %RH
Output resolution	0.1 %RH

Wind Measurement Performance

Wind Speed

Observation range	0 ... 60 m/s (134 mph)
Response time	0.25 s
Available variables	Average, maximum, and minimum
Accuracy	±3 % at 10 m/s (22 mph)
Output resolution	0.1 m/s (km/h, mph, knots)

Wind Direction

Azimuth	0 ... 360°
Response time	0.25 s
Available variables	Average, maximum, and minimum
Accuracy	±3.0° at 10 m/s (22 mph)
Output resolution	1°
Averaging time	1 ... 3600 s (= 60 min), at 1 s steps, on the basis of samples taken at 4, 2, or 1 Hz rate (configurable)

Precipitation Measurement Performance

Rainfall	Cumulative accumulation after the latest automatic or manual reset
Collecting area	60 cm ² (9.3 in ²)
Output resolution	0.01 mm (0.001 in)
Field accuracy for daily accumulation	Better than 5 %, weather-dependent
Rain	
Duration	Counting each 10-second increment whenever droplet detected
Duration output resolution	10 s
Intensity	Running 1-minute average in 10-second steps
Intensity observation range	0 ... 200 mm/h (0 ... 7.87 in/h) (broader range with reduced accuracy)
Intensity output resolution	0.1 mm/h (0.01 in/h)
Hail	
Duration	Counting each 10-second increment whenever hailstone detected
Output resolution	0.1 hits/cm ² (1 hits/in ²), 1 hit
Intensity	1-minute running average in 10-second steps
Duration output resolution	10 s
Intensity output resolution	0.1 hits/cm ² h (1 hits/in ² h), 1 hit/h

Inputs and Outputs

Operating voltage	6 ... 24 VDC (-10 ... +30 %)
Average power consumption	Minimum: 0.1 mA at 12 VDC (SDI-12 standby) Typical: 3.5 mA at 12 VDC with typical measuring intervals Maximum: 15 mA at 6 VDC (with constant measurement of all parameters)
Heating voltage	Options: DC, AC, full-wave rectified AC 12 ... 24 VDC (-10 ... +30 %) 12 ... 17 VACrms (-10 ... +30 %)
Typical heating current	12 VDC: 0.8 A 24 VDC: 0.4 A
Digital outputs	SDI-12, RS-232, RS-485, RS-422
Communication protocols	SDI-12 v1.3 ASCII automatic and polled NMEA 0183 v3.0 with query option

Analog Input Options

Solar radiation	Kipp & Zonen CMP3
Level measurement	IRU-9429
Tipping bucket rain gauge	Vaisala Rain Gauge RG13
Temperature	Pt1000

Analog mA Output Options

Wind speed	0 ... 20 mA or 4 ... 20 mA
Wind direction	0 ... 20 mA or 4 ... 20 mA
Load impedance	Max. 200 Ω

Operating Environment

Operating temperature	-52 ... +60 °C (-60 ... +140 °F)
Storage temperature	-60 ... +70 °C (-76 ... +158 °F)
Relative humidity	0 ... 100 %RH
Pressure	600 ... 1100 hPa
Wind	0 ... 60 m/s (0 ... 134 mph)

Compliance

EMC compliance	IEC 61326-1 IEC 60945 IEC 55022:2010 Class B
Environmental	IEC 60068-2-1, 2, 6, 14, 30, 31, 52, 78 IEC60529 VDA 621-415
Maritime	DNVGL-CG-0339 IEC 60945



Vaisala Calibration Includes

- Calibration at Vaisala preselected points or customer-selected points within the instrument's measurement range
- Instrument adjustment
- Traceability to industry recognized standards
- Calibration certificate
- Service report
- Wearing parts
- Functionality testing according to manufacturer specification

Even the best high-performance measurement instruments require regular calibration and maintenance to ensure they continue providing the most accurate data possible.



Why Calibrate

Vaisala's best-in-class measurement instruments provide the highest accuracy and precision across all types of applications. But even the highest performing measurement instruments drift over time. Drift can be caused by dirt and chemicals in the ambient air or simply by temperature changes. Regular calibration protects against incremental sensor drift and verifies that units are operating within the given specifications. Choosing the right calibration laboratory and service supplier can be as important for lifetime accuracy and reliability as the initial selection of the instrument. Our

high-performance calibration laboratories were established in 1958 and we are continually improving our technology, facilities, and capabilities to provide the high-quality services you expect from Vaisala.

Accredited Calibration

Many industries are required by regulatory bodies to comply with strict quality standards. We offer calibration services accredited by the world's leading accreditation authorities. ISO/IEC 17025 is the international standard used to accredit testing and calibration laboratories for measured quantities.

Standard Calibration

Standard calibration is regularly performed on our instruments before they leave the factory, with the selected calibration points varying by instrument. In order to maintain accuracy and avoid sensor drift over time, the equivalent calibration can also be purchased later. Our standard calibrations are traceable to national or international standards and meet ISO 9001 quality management standards. Calibration services in our laboratory in Boston, USA also meet ANSI/NSCL Z540.1 requirements.

Calibration Terminology

- **Calibration** – comparing the output of a measurement instrument against a reference instrument and reporting the result.
- **Adjustment** – changing the output to correspond to the output of a reference instrument.
- **Traceability** – a traceable measurement can be related to appropriate national or international standards through a documented, unbroken chain of comparisons.
- **Uncertainty** – a doubt that exists about the result of any measurement, calculated via three main sources: the reference used, the unit under calibration, and the calibration process used.
- **Calibration Interval** – the time between successive calibrations of an instrument.



Custom Calibration

If specific calibration points critical to your operation are needed, we also offer custom calibration. Calibrating and adjusting your instrument specifically for the critical points where the product is used will ensure reliable and accurate measurement in your application.

Let Us Care for and Protect Your Instruments!



Calibration as Part of Repair Services

If your instrument requires repairing, you can simply let us take care of it. The service includes repairing of the instrument with original parts, functionality testing, and the calibration you need. You can be sure to receive the instrument in its original specification.

Premium and Calibration Care Agreements

As your instrument provider, we want to make sure that your instruments get the best possible care and you get the best possible value from your investment.

For that reason we are offering two service options, Premium Care and Calibration Care.



Premium Care:

Premium Care protects your investment. If your product is damaged or broken for any reason, return it to us and we will repair or replace it free of charge. It's that simple.







Calibration Care:

Calibration Care is a multiyear calibration agreement with several benefits compared to single purchases of services, from discounted cost to priority service.

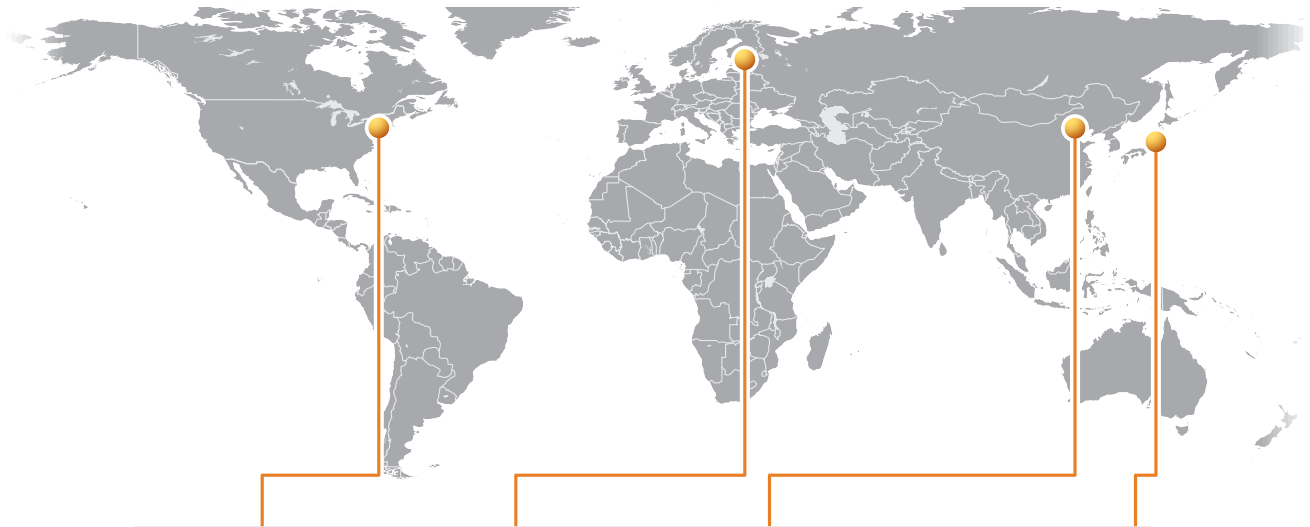
Benefits	Calibration Care	Premium Care
Customer loyalty discounted pricing	✓	✓
No price changes during the multiyear agreement	✓	✓
Calibration settings pre-registered for efficient processing of all service orders	✓	✓
Free shipping, both to and from Vaisala	✓	✓
Priority handling of your order	✓	✓
Non-standard or special calibration requirements available	✓	✓
Full service with repairs and maintenance included		✓

Vaisala Service Centers



Boston, USA	Helsinki, Finland	Beijing, China	Tokyo, Japan
STANDARD CALIBRATION SERVICES			
Relative Humidity	Relative Humidity	Relative Humidity	Relative Humidity
Temperature	Temperature	Temperature	Temperature
Dew Point	Dew Point	Dew Point	Dew Point
Barometric Pressure	Barometric Pressure	Barometric Pressure	Barometric Pressure
Carbon Dioxide	Carbon Dioxide Hydrogen Peroxide	Carbon Dioxide	Carbon Dioxide
ACCREDITED CALIBRATION SERVICES			
 CALIBRATION LABORATORY CERTIFICATE # 2983.01	 FINAS FINAS ACCREDITATION SERVICE K008 (EN ISO/IEC 17025)	 CNAS CALIBRATION CNAS L10243	 JCSS JCSS 0123
Relative Humidity	Relative Humidity	Relative Humidity	Relative Humidity
Temperature	Temperature	Temperature	
Dew Point	Dew Point		Dew Point
Barometric Pressure	Barometric Pressure	Barometric Pressure	
	Carbon Dioxide		

For more information about our services and how to order, please go to www.vaisala.com/calibration.

Vaisala Contact Information

EUROPE

FINLAND

Vaisala Oyj
P.O. Box 26
FI-00421
Helsinki
FINLAND
Tel. +358 9 894 91
www.vaisala.com/requestinfo
www.vaisala.com

BENELUX

Contact: Bonn Office
Adenauerallee 15
D-53111 Bonn
GERMANY
Tel. +49 228 249 710
Fax +49 228 24971 11
Tel. Netherlands : +31 (0) 6 28422031
Tel. Belgium: +32 (0) 477 855 038
benelux.sales@vaisala.com
www.vaisala.com

FRANCE

Vaisala SAS
Lyon Office
73 cours Albert Thomas
F-69003 LYON
FRANCE
Tel. +33 04 37 915 730
+ 0800 67 67 26
ventes@vaisala.com
www.vaisala.fr

Vaisala SAS
Paris Office
39/41, avenue des 3 Peuples
Bât. B - Entrée B1
F-78180
Montigny-le-Bretonneux
FRANCE
Tel. +33 1 3057 2728
+ 0800 67 67 26
Fax +33 1 3096 0858
ventes@vaisala.com
www.vaisala.fr

GERMANY

Vaisala GmbH
Bonn Office
Adenauerallee 15
D-53111 Bonn GERMANY
Tel. +49 228 24971 0
Fax +49 228 24971 11
National: 0800VAISALA
vertrieb@vaisala.com
www.vaisala.de

Vaisala GmbH
Hamburg Office
Notkestraße 11
D-22607 Hamburg
GERMANY
Tel. +49 40 839030
Tel. +49 40 83903110
National: 0800VAISALA
vertrieb@vaisala.com
www.vaisala.de

ITALY

Vaisala Oyj
Milan Office
Via Carlo Cattaneo 9
21013 Gallarate (VA)
ITALY
Tel. +39 0331 1600221
Tel. +39 349 5323354

SWEDEN

Vaisala Oyj
Malmö Office
WTC / Jungmansgatan 12
S-211 11 Malmö SWEDEN
Tel. +46 40 298 991
National: 0200 848 848
forsaljning@vaisala.com
www.vaisala.com

Vaisala Oyj
Stockholm Office
Tel. +46 76 768 60 60
forsaljning@vaisala.com
www.vaisala.com

SWITZERLAND

Contact: Bonn Office
Adenauerallee 15
D-53111 Bonn
GERMANY
Tel. +49 228 24971 0
Fax +49 228 24971 11
vertrieb@vaisala.com
www.vaisala.de

UNITED KINGDOM

Vaisala Ltd
Bury St. Edmunds Office
Unit 2b, Hillside Business Park
Kempson Way
Bury St. Edmunds
Suffolk IP32 7EA
UNITED KINGDOM
Tel. +44 121 683 5620
Fax +44 121 683 1299
uksales@vaisala.com
www.vaisala.com

Vaisala Ltd
Birmingham Office
Elm House
351 Bristol Road
Birmingham B5 7SW
UNITED KINGDOM
Tel. +44 121 683 1200
Fax +44 121 683 1299
uksales@vaisala.com
www.vaisala.com

Continued overleaf

Vaisala Contact Information

AMERICAS

Vaisala Inc.
Boston Office
10-D Gill Street
Woburn, MA 01801
USA
Tel. +1 781 933 4500
Toll free 1-888-VAISALA (824-7252)
Fax +1 781 933 8029
instruments@vaisala.com
www.vaisala.com

BRAZIL

Vaisala Serviços de Marketing Ltda
Rio de Janeiro Office
Ladeira da Glória 26
Bloco 3 – Studio 206
Glória
Rio de Janeiro, RJ
22211-120
BRAZIL
Tel: +55 21 2263 3006

CANADA

Vaisala Canada Inc.
Vancouver Office
200-15225 104 Avenue
Surrey BC, V3R 6Y8
CANADA
Tel. +1 604 273 6850
Toll free 1-800 683 8374
Fax +1 604 273 2874
instruments@vaisala.com
www.vaisala.com

MÉXICO

Vaisala México Limited
México Office
Sócrates 140
Col. Polanco Sección II
Del. Miguel Hidalgo
CP 11540, CDMX
MÉXICO
Tel: +52 (55) 5557 3917

ASIA AND PACIFIC

AUSTRALIA

Vaisala Pty Ltd Melbourne Office 3
Guest Street
Hawthorn, VIC 3122
AUSTRALIA
Tel: +(61 3) 9815 6700
Fax +(61 3) 9815 6799
ABN 58 006 500 616
sales.melbourne@vaisala.com
www.vaisala.com

CHINA

Vaisala China Ltd
Beijing Office
Floor 2, EAS Building
No. 21, Xiao Yun Road
Chaoyang District
100027, Beijing
CHINA
Tel. +86 10 5827 4100
Fax +86 10 5827 1155
National hotline 400 810 0126
chinasales@vaisala.com
cn.vaisala.com

Vaisala China Ltd
Shanghai Branch
Room D, Floor 12, Meihuan Building
No. 107 Zhongshan South 2nd Road
Xuhui District 200032
Shanghai
CHINA
Tel: +86 21 5011 1581/2/3
Fax: +86 21 5011 1580
National hotline 400 810 0126
chinasales@vaisala.com
cn.vaisala.com

Vaisala China Ltd
Shenzhen Branch
Room 18 F1
Fortune Plaza
No. 88, Fuhua 3rd Road
Central District 518033
Shenzhen
CHINA
Tel. +86 755 82792403
Fax +86 755 82792404
National hotline 400 810 0126
chinasales@vaisala.com
cn.vaisala.com

JAPAN

Vaisala KK
Tokyo Office
Jimbocho Mitsui Building 16F
1-105 Kanda-Jimbocho
Chiyoda-ku
Tokyo 101-0051
JAPAN
Tel. + 81 3 5259 5960
Fax + 81 3 5259 5961
sales.japan@vaisala.com
www.vaisala.co.jp

Vaisala KK
Osaka Office
Orix Honmachi Bldg 4F
1-4-1 Nishihonmachi
Nishi-ku, Osaka-shi
Osaka 550-0005
JAPAN
Tel. +81 6 6453 8770
Fax +81 6 7635 5033
sales.japan@vaisala.com
www.vaisala.co.jp

Vaisala KK
Nagoya Sales Office
GS Sakae Building 3F
5-26-39 Sakae
Naka-ku
Nagoya-shi
Aichi 460-0008
JAPAN
Tel. +81 52 261 3577
Fax. +81 52 308 4966
sales.japan@vaisala.com
www.vaisala.co.jp

Vaisala KK
Fukuoka Sales Office
AS OFFICE Hakata
1-11-27 Hakataeki-Minami
Hakata-ku
Fukuoka-shi 812-0016
Tel: +81 92 482 6511
Fax: +81 92 510 7126
sales.japan@vaisala.com
www.vaisala.co.jp

MALAYSIA

Vaisala Sdn Bhd
Regional Office Malaysia
W11-A0, Level 11, West Block
Wisma Selangor Dredging
142-C Jalan Ampang
50450 Kuala Lumpur
MALAYSIA
Tel: +603 2163 3363
Fax: +603 2164 3363

This material is subject to copyright protection, with all copyrights retained by Vaisala and its individual partners. All rights reserved. Any logos and/or product names are trademarks of Vaisala or its individual partners. The reproduction, transfer, distribution or storage of information contained in this brochure in any form without the prior written consent of Vaisala is strictly prohibited. All specifications – technical included – are subject to change without notice.

