

FRESH WATER PUMPING CATALOG



Having issues with your SymCom product?
Call our **Technical Support Team** with
your questions.

800-843-8848
technicalsupport@symcom.com

To Our Customers:

Many times, issues with a product are the result of an incorrect setting. By calling us, SymCom's Technical Support Team, the issue can be eliminated. With our experienced staff, we can go over the settings with you to ensure that everything is set correctly. We are well versed in all products and typical applications for SymCom products. Chances are, we have run into your issue before.

The best way to fix an issue is to have you at the unit when you call, that way, we can make sure that all issues are fixed the first time. In the event that we determine your unit is not functioning properly, we will issue you a return material authorization (RMA) number to send the unit in for evaluation. If the unit is determined to be faulty and covered under warranty, we will replace the unit at no charge to you. No need to contact your distributor for a replacement. A new unit will be sent to you directly if it is covered under warranty.

So call our friendly support staff today for any and all of your questions regarding your SymCom products.

Best Regards,

SymCom Technical Support Team

Note: The use of flow restrictors, unusually high head pressures, or low water conditions at the time of calibration may interfere with the detection of dead-head and dry-well conditions.

TABLE OF CONTENTS

Submersible Pumps - Optimized Protection

Whose Control Box do you have?

Franklin™, CentriPro™ or Pentek® 2

115VAC

1/3-1/2hp... 111-Insider-P

230VAC

1/3-1hp... 231-Insider-P

Grundfos® 4

230VAC

1/3-1hp... 232-Insider

1/3-3hp... 234-P

Don't need a control box? 8

115VAC

1/3-1hp... 111P

230VAC

1/3-1.5hp... 233P-1.5

1/3-3hp... 233P

5-15hp... 235P

Want a PumpSaverPlus in its own NEMA box? 12

115VAC

1/3-1hp... 111P-ENCL

230VAC

1/3-1.5hp... 233P-1.5-ENCL

1/3-3hp... 233P-ENCL

5-15hp... 235P-ENCL

Hand-held Diagnostic Tool - Informer 16

Any Other Pump:..... 18

Single-Phase Programmable pump protection... 77C-KW/HP (2-800 Amps)

Single-Phase Low-range prog. pump protection... 77C-LR-KW/HP (1-9 Amps)

Three-Phase Programmable overload relay... 777-P2

Three-Phase Low-range prog. overload relay... 777-LR-P2

Three-Phase High Control Voltage prog. overload relay... 777-HVR-P2

Three-Phase Programmable power monitor... 777-KW/HP-P2

Three-Phase Low-range prog. power monitor... 777-LR-KW/HP-P2

Three-Phase Medium-Low range prog. power monitor... 777-MLR-KW/HP-P2

Three-Phase High Control Voltage prog. power monitor... 777-HVR-KW/HP-P2

Ancillary Products:

Do you need to know the liquid level in any tank? 24

Liquid Level Sensor Relay (DIN Rail or surface mount)... 460-15-100-LLS

Liquid Level Control Relay (8-pin plug in)... PC-xxx-LLC-CZ

Liquid Level Control Relay (8-pin plug in)... PC-xxx-LLC-GM

Typical Wiring Diagrams..... 28

Installation Instructions 32

Product Dimensions 54

Other SymCom Products 57

Franklin™, CentriPro™ or Pentek® Control Box
1/3 - 1/2hp, 115VAC - Model 111-Insider-P
1/3 - 1hp, 230VAC - Model 231-Insider-P



SymCom's Model 111-Insider-P single-phase PumpSaver®Plus fits inside 1/3 and 1/2, 115V control boxes and the 231-Insider-P fits in 1/3, 1/2, 3/4, and 1 hp, 230V control boxes. Both models are designed to protect single-phase pumps from dry-well, dead-head, jammed impeller, rapid-cycle, overvoltage, and undervoltage conditions.

A calibration adjustment allows the Insider to be calibrated to your specific pumping applications, thereby reducing the possibility of false or nuisance tripping. A unique microcontroller-based voltage and current-sensing circuit constantly monitors the incoming power for fluctuations, overcurrent, and undercurrent. When an abnormality, such as loss of suction is detected, the PumpSaver® deactivates its output relay and directly disconnects the pump motor. The PumpSaver® then begins its user-selectable restart delay (dry-well recovery) timer. When the timer counts to zero or power is removed and reapplied, the PumpSaver® reactivates its output relay and turns the pump back on. By leaving the restart delay knob in the reset position, the PumpSaver® will operate in manual reset mode.

The Insider communicates with a hand-held diagnostics tool called the Informer (sold separately). The Informer displays parameters including calibration points, trip points, run time and last faults. An IR Kit-12 (12" fiber optic kit) is included with each Insider, allowing the Informer to access these parameters even when the Insider is enclosed in a control box. This is valuable for troubleshooting the pump while it is running.

NOTE: The PumpSaver®Plus models have a sensitivity adjustment for the dry-well trip point. After calibration is done, you can adjust the sensitivity for the dry-well/dead-head trip point from 70-90% of the full load. This makes the unit even more adaptable to varying pumping applications. If you have a very low producing well, you increase the sensitivity closer to the 90% mark, or if you have a very heavy producing well, you would decrease the sensitivity around the 70% mark.

Specifications

Functional Specifications	
Adjustments/Settings	
Overcurrent	125% of calibration point
Underload (dry-well)	Adjustable (70 to 90% of calibrated run power)
Overvoltage	
111-Insider-P	132.5VAC
231-Insider-P	265VAC
Undervoltage	
111-Insider-P	95VAC
231-Insider-P	190VAC
Number of restarts allowed in a 60-sec. period (rapid-cycling)	4
Trip Delay Times	
Overcurrent	5 seconds
Dry-well	4 seconds
Restart Delay Times	
Over/undervoltage	2 seconds
All other faults	Manual, 2-225 minutes
Input Characteristics	
Supply Voltage	
111-Insider-P	115VAC
231-Insider-P	230VAC
Load Range:	
111-Insider-P	1/3 - 1/2 hp
231-Insider-P	1/3 - 1 hp
Frequency	50/60Hz (Note: 50Hz will increase all delay timers by 20%)
Output Characteristics	
Output Contact Rating-SPST	
111-Insider-P	1/2hp@120VAC (17 amps max.)
231-Insider-P	1hp@ 240VAC (17 amps max.)
General Characteristics	
Operating Temperature	-40° to 60° C (-40° to 140° F)
Maximum Input Power	5 W
Safety Marks:	
cUR*	UL508, C22.2 No. 14
Weight	10 oz.
Mounting Methods:	Inside a Franklin™, Pentek® or CentriPro™ control box

*The 111-Insider-P and 231-Insider-P are approved by UL for use in the Franklin™, Pentek®, and CentriPro™ type 3R control boxes when installed as described in the installation instructions. The 111-Insider-P and 231-Insider-P are not intended to provide overload protection, and should be used with thermally or impedance protected motors only.

For a typical wiring diagram see pages 28-29.

For installation instructions see page 32.

How to order:

111-Insider-P (1/3 - 1/2hp, 115VAC, includes IR Kit-12)

231-Insider-P (1/3 - 1hp, 230VAC, includes IR Kit-12)



www.SymCom.com

...your electronic control & protection specialists

(605) 348.5580 / (800) 843.8848 / Fax (605) 348.5685

customerservice@symcom.com / technicalsupport@symcom.com

Grundfos control box, 1/3 - 1hp, 230VAC - Model 232-Insider



The Model 232-Insider single-phase PumpSaver® fits inside 1/2, 3/4, and 1hp, 230V Grundfos® control boxes. It is a pump monitor designed to protect single-phase pumps from dry-well, deadhead, jammed impeller, overvoltage and undervoltage conditions.

A calibration adjustment allows the Insider to be calibrated to your specific pumping applications, thereby reducing the possibility of false or nuisance tripping. A unique microcontroller-based voltage and current-sensing circuit constantly monitors the incoming power for fluctuations, overcurrent, and undercurrent. When an abnormality, such as loss of suction is detected, the PumpSaver® deactivates its output relay and directly disconnects the pump motor. The PumpSaver® then begins its user-selectable restart delay (dry-well recovery) timer. When the timer counts to zero or power is removed and reapplied, the PumpSaver® reactivates its output relay and turns the pump back on. By leaving the restart delay knob in the reset position, the PumpSaver® will operate in manual reset mode.

The Insider communicates with a hand-held diagnostics tool called the Informer (sold separately). The Informer displays parameters including calibration points, trip points, run time and last faults. An IR Kit-12 (12" fiber optic kit) is included with each Insider, allowing the Informer to access these parameters even when the Insider is enclosed in a control box. This is valuable for troubleshooting the pump while it is running.



www.SymCom.com

... your electronic control & protection specialists

(605) 348.5580 / (800) 843.8848 / Fax (605) 348.5685

customerservice@symcom.com / technicalsupport@symcom.com

Specifications

Functional Specifications	
Adjustments/Settings	
Overcurrent	125% of calibration point
Underload (dry-well)	Approx. 80% of calibration point
Overvoltage	265VAC
Undervoltage	190VAC
Trip Delay Times	
Overcurrent	5 seconds
Dry-well	4 seconds
Restart Delay Times	
Over/undervoltage	2 seconds
All other faults (dry-well recovery timer)	Manual, 2-225 Minutes
Input Characteristics	
Supply Voltage	230VAC
Load Range	1/3 - 1 hp
Frequency	50/60Hz (Note: 50Hz will increase all delay timers by 20%)
Output Characteristics	
Output Contact Rating-SPST	1hp@240VAC (17 amps max.)
General Characteristics	
Operating Temperature	-40° to 70° C (-40° to 158° F)
Maximum Input Power	5 W
Safety Marks	
UL	UL508
CSA	C22.2 No. 14
Weight	10 oz.
Mounting Methods	Grundfos® Control Box

For a typical wiring diagram see page 30.

For installation instructions see page 32.

How to order:

232-Insider (Grundfos control box, 1/3 - 1hp, 230VAC)



www.SymCom.com

...your electronic control & protection specialists

(605) 348.5580 / (800) 843.8848 / Fax (605) 348.5685

customerservice@symcom.com / technicalsupport@symcom.com

Grundfos control box, 1/3 - 3hp, 230VAC - Model 234-P



The SymCom PumpSaver®Plus Model 234-P is designed to be mounted inside a Grundfos® control box to protect 1/3-3hp, 2- or 3-wire, 230V pumps.

The Model 234-P protects single-phase pumps from dry-well, dead-head, rapid-cycle, jammed-impeller, and over/undervoltage conditions. Typical applications include residential waterwells, commercial waterwells, irrigation wells, and golf course and other sprinkler systems.

A calibration adjustment allows the PumpSaver®Plus to be calibrated to your specific pumping applications, thereby reducing the possibility of false or nuisance tripping. A unique microcontroller-based voltage and current-sensing circuit constantly monitors the incoming power for fluctuations, overcurrent, and undercurrent. When an abnormality, such as loss of suction is detected, the PumpSaver®Plus deactivates its output relay and directly disconnects the pump motor. The PumpSaver®Plus then begins its user-selectable restart delay (dry-well recovery) timer. When the timer counts to zero or power is removed and reapplied, the PumpSaver®Plus reactivates its output relay and turns the pump back on. By leaving the restart delay knob in the reset position, the PumpSaver®Plus will operate in manual reset mode.

The PumpSaver®Plus communicates with a hand-held diagnostics tool called the Informer (sold separately). The Informer displays parameters including calibration points, trip points, run time and last faults. An IR Kit-12 (12" fiber optic kit) allows the Informer to access these parameters even when the PumpSaver®Plus is enclosed in a control box. This is valuable for troubleshooting the pump while it is running.

NOTE: The PumpSaver®Plus models have a sensitivity adjustment for the dry-well trip point. After calibration is done, you can adjust the sensitivity for the dry-well/dead-head trip point from 70-90% of the full load. This makes the unit even more adaptable to varying pumping applications. If you have a very low producing well, you increase the sensitivity closer to the 90% mark, or if you have a very heavy producing well, you would decrease the sensitivity around the 70% mark. The Model 234-P is not recommended for use with the Grundfos® Deluxe Control Box.



www.SymCom.com

...your electronic control & protection specialists

(605) 348.5580 / (800) 843.8848 / Fax (605) 348.5685
customerservice@symcom.com / technicalsupport@symcom.com

Specifications

Functional Specifications	
Adjustments/Settings	
Overcurrent	125% of calibration point
Underload (dry-well)	Adjustable (70 - 90% of calibrated run power)
Overvoltage	265VAC
Undervoltage	190VAC
Number of restarts allowed in a 60-second period (rapid-cycling)	4
Trip Delay Times	
Overcurrent	5 seconds
Dry-well	4 seconds
Restart Delay Times	
Over/undervoltage	2 seconds
All other faults (dry-well recovery timer)	Manual, 2-225 Minutes
Input Characteristics	
Supply Voltage	230VAC
Load Range	1/3 - 3 hp
Frequency	50/60Hz (Note: 50Hz will increase all delay timers by 20%)
Output Characteristics	
Output Contact Rating-SPST	3 hp@240VAC (17 amps max.)
General Characteristics	
Operating Temperature	-40° to 45° C (-40° to 113° F)
Maximum Input Power	5 W
Dimensions	Fitted to Grundfos® Control Box
Weight	14 oz.
Mounting Methods	Grundfos® Control Box

For a typical wiring diagram see page 30.

How to order:

234-P (Grundfos control box, 1/3 - 3hp, 230VAC)



www.SymCom.com

...your electronic control & protection specialists

(605) 348.5580 / (800) 843.8848 / Fax (605) 348.5685

customerservice@symcom.com / technicalsupport@symcom.com

1/3 - 1hp, 115VAC - Model 111P

1/3 - 1.5hp, 230VAC - Model 233P-1.5

1/3 - 3hp, 230VAC - Model 233P



The PumpSaver®Plus Models 111P (115 volt, 1/3 to 1hp); 233P-1.5 (230 volt, 1/3 to 1.5hp); and 233P (230 volt, 1/3 to 3hp) protect pumps from dry-well, dead-head, jammed impeller, overvoltage/undervoltage conditions and now rapid-cycle protection whether the pressure switch is mounted before or after our unit.

A calibration adjustment allows the Insider to be calibrated to your specific pumping applications, thereby reducing the possibility of false or nuisance tripping. A unique microcontroller-based voltage and current-sensing circuit constantly monitors the incoming power for fluctuations, overcurrent, and undercurrent. When an abnormality, such as loss of suction is detected, the PumpSaver® deactivates its output relay and directly disconnects the pump motor. The PumpSaver® then begins its user-selectable restart delay (dry-well recovery) timer. When the timer counts to zero or power is removed and reapplied, the PumpSaver® reactivates its output relay and turns the pump back on.

The PumpSaver®Plus communicates with a hand-held diagnostics tool called the Informer (sold separately). The Informer displays parameters including calibration points, trip points, run time and last faults. An IR Kit-12 (12" fiber optic kit) allows the Informer to access these parameters even when the PumpSaver®Plus is enclosed in a control box. This is valuable for troubleshooting the pump while it is running.

Special considerations for pump cables larger than #10 AWG: In some cases where larger motors are installed with deep set pumps, pump cables are used that exceed the PumpSaver's terminal size. In these conditions, a short splice of #10 AWG or #12 AWG may be a solution at the control box. Note: All local, state and national electric codes should be followed when applying this solution.

NOTE: The PumpSaver®Plus models have a sensitivity adjustment for the dry-well trip point. After calibration is done, you can adjust the sensitivity for the dry-well/dead-head trip point from 70-90% of the full load. This makes the unit even more adaptable to varying pumping applications. If you have a very low producing well, you increase the sensitivity closer to the 90% mark, or if you have a very heavy producing well, you would decrease the sensitivity around the 70% mark.



www.SymCom.com

...your electronic control & protection specialists

(605) 348.5580 / (800) 843.8848 / Fax (605) 348.5685
customerservice@symcom.com / technicalsupport@symcom.com

Specifications

Functional Specifications	
Adjustments/Settings Overcurrent Underload (dry-well) Overvoltage 111P 233P, 233P-1.5 Undervoltage 111P 233P, 233P-1.5 Number of restarts allowed in a 60-sec. period (rapid-cycling) Trip Delay Times Overcurrent Dry-well Restart Delay Times Over/undervoltage All other faults	125% of calibration point Adjustable (70 to 90% of calibrated run power) 132.5VAC 265VAC 95VAC 190VAC 4 5 seconds 4 seconds 2 seconds Manual, 2-225 Minutes
Input Characteristics	
Supply Voltage: 111P 233P-1.5, 233P Load Range: 111P 233P-1.5 233P Frequency:	115VAC 230VAC $\frac{1}{3}$ - 1 hp $\frac{1}{3}$ - 1.5 hp $\frac{1}{3}$ - 3 hp 50/60Hz (Note: 50Hz will increase all delay timers by 20%)
Output Characteristics	
Output Contact Rating-SPST: 111P 233P-1.5 233P	1hp@120VAC (16 amps max.) 1.5hp@240VAC (10 amps max.) 3hp@240VAC (17 amps max.)
General Characteristics	
Operating Temperature Maximum Input Power Wire Gauge Terminal Torque Safety Marks: cUL Listed Dimensions Weight Mounting Methods:	-40° to 55° C (-40° to 131° F) 5 W Solid or Stranded 10 - 22AWG 13 in.-lbs. UL508, C22.2 No. 14 2.9" H x 5.25" W x 2.913" D 14 oz. #8 screws

For a typical wiring diagram see page 31.

For installation instructions see page 32.

For product dimensions see page 54.

How to order:

111P ($\frac{1}{3}$ - 1hp, 115VAC)

233P-1.5 ($\frac{1}{3}$ - 1.5hp, 230VAC)

233P ($\frac{1}{3}$ - 3hp, 230VAC)



www.SymCom.com

...your electronic control & protection specialists

(605) 348.5580 / (800) 843.8848 / Fax (605) 348.5685

customerservice@symcom.com / technicalsupport@symcom.com

5 - 15hp, 230VAC - Model 235P



SymCom's Model 235P PumpSaver®Plus is designed to protect 5-15 hp, 230V, single-phase pumps from dry-well, dead-head, jammed impeller and overvoltage and undervoltage conditions.

A calibration adjustment allows the Model 235P to be calibrated to your specific pumping applications, thereby reducing the possibility of false or nuisance tripping. A unique microcontroller-based voltage and current-sensing circuit constantly monitors the incoming power for fluctuations causing overcurrent and undercurrent. When an abnormality, such as loss of suction is detected, the PumpSaver®Plus deactivates its output relay and directly disconnects the pump motor.

The PumpSaver®Plus communicates with a hand-held diagnostics tool called the Informer (sold separately). The Informer displays parameters including calibration points, trip points, run time and last faults. An IR Kit-12 (12" fiber optic kit) allows the Informer to access these parameters even when the PumpSaver®Plus is enclosed in a control box. This is valuable for troubleshooting the pump while it is running.

An external current transformer is required for operation (sold separately).

Size	Current	CT*
5 - 7½ HP	27.5 - 42.1	50:5
10 HP	51	75:5
15 HP	75	100:5

Special considerations for pump cables larger than #10 AWG: In some cases where larger motors are installed with deep set pumps, pump cables are used that exceed the PumpSaver's terminal size. In these conditions, a short splice of #10 AWG or #12 AWG may be a solution at the control box. Note: All local, state and national electric codes should be followed when applying this solution.

NOTE: The PumpSaver®Plus models have a sensitivity adjustment for the dry-well trip point. After calibration is done, you can adjust the sensitivity for the dry-well/dead-head trip point from 70-90% of the full load. This makes the unit even more adaptable to varying pumping applications. If you have a very low producing well, you increase the sensitivity closer to the 90% mark, or if you have a very heavy producing well, you would decrease the sensitivity around the 70% mark.

Specifications

Functional Specifications	
Adjustments/Settings	
Overcurrent	125% of calibration point
Underload (dry-well)	Adjustable (70 to 90% of calibrated run power)
Overvoltage	265VAC
Undervoltage	190VAC
Number of restarts allowed in a 60-sec. period (rapid-cycling)	4
Trip Delay Times	
Overcurrent	5 seconds
Dry-well	4 seconds
Restart Delay Times	
Over/undervoltage	2 seconds
All other faults	Manual, 2-225 Minutes
Input Characteristics	
Supply Voltage	230VAC
Load Range	5 - 15 hp
Frequency	50/60Hz (Note: 50Hz will increase all delay timers by 20%)
Output Characteristics	
Output Contact Rating-SPST	A300, 720VA@240VAC (10 amps max.)
General Characteristics	
Operating Temperature	-40° to 55° C (-40° to 131° F)
Maximum Input Power	5 W
Wire Gauge	Solid or Stranded 10 - 22AWG
Terminal Torque	13 in.-lbs.
Safety Marks	
cUL Listed	UL508, C22.2 No. 14
Dimensions	2.9" H x 5.25" W x 2.913" D
Weight	14 oz.
Mounting Methods	#8 screws

For a typical wiring diagram see page 31.

For installation instructions see page 32.

For product dimensions see page 54.

How to order:

235P* (5 - 15hp, 230VAC)

* current transformer sold separately



www.SymCom.com

...your electronic control & protection specialists

(605) 348.5580 / (800) 843.8848 / Fax (605) 348.5685

customerservice@symcom.com / technicalsupport@symcom.com

- 111P-ENCL (enclosure with 111P mounted)
- 233P-1.5-ENCL (enclosure with 233P-1.5 mounted)
- 233P-ENCL (enclosure with 233P mounted)
- 235P-ENCL (enclosure with 235P mounted)



The ENCL enclosure is a metal electrical box that meets the National Electrical Manufacturers Association's and Underwriter Laboratory's standard for a 3R rating. The ENCL box can house several different single-phase SymCom PumpSaver®Plus models. It has three clear lenses on the cover for viewing the LEDs on the PumpSaver®Plus, allowing the customer to determine the units operational status and to provide access to the IR signal for use with the Informer diagnostic tool.

The ENCL enclosure is sold ONLY in conjunction with the single-phase SymCom PumpSaver®Plus models.

Special considerations for pump cables larger than #10 AWG: In some cases where larger motors are installed with deep set pumps, pump cables are used that exceed the PumpSaver's terminal size. In these conditions, a short splice of #10 AWG or #12 AWG may be a solution at the control box. Note: All local, state and national electric codes should be followed when applying this solution.

An external current transformer is required for operation of the Model 235P (sold separately).

Size	Current	CT*
5 - 7½ HP	27.5 - 42.1	50:5
10 HP	51	75:5
15 HP	75	100:5

Specifications - Enclosure Only

Functional Specifications	
Classification	NEMA 3R
Grounding	Two separate ground tabs
General Characteristics	
Dimensions - enclosure	8.3" H x 5.36" W x 3.68" D
Front Cover	Secured by one capture screw. Cover contains three clear lenses, two for viewing the diagnostic LED's on PumpSaver® and one for access to IR Signal for Informer
Weight	2.20 lbs.
Mounting Method	Surface mount (two concave mounting holes)
Knock-outs (seven)	½" (1 each side and 2 in bottom) ¾" (1 each side and 1 in bottom)



www.SymCom.com

...your electronic control & protection specialists

(605) 348.5580 / (800) 843.8848 / Fax (605) 348.5685

customerservice@symcom.com / technicalsupport@symcom.com

Specifications - PumpSaver®Plus

Functional Specifications	
Adjustments/Settings Overcurrent Underload (dry-well) Overvoltage 111P 233P, 233P-1.5, 235P Undervoltage 111P 233P, 233P-1.5, 235P Number of restarts allowed in a 60-sec. period (rapid-cycling) Trip Delay Times Overcurrent Dry-well Restart Delay Times Over/undervoltage All other faults	125% of calibration point Adjustable (70 to 90% of calibration point) 132.5VAC 265VAC 95VAC 190VAC 4 5 seconds 4 seconds 2 seconds Manual, 2-225 Minutes
Input Characteristics	
Supply Voltage 111P 233P-1.5, 233P, 235P Load Range 111P 233P-1.5 233P 235P Frequency	115VAC 230VAC 1/3 - 1 hp 1/3 - 1.5 hp 1/3 - 3 hp 5 -15 hp 50/60Hz (Note: 50Hz will increase all delay timers by 20%)
Output Characteristics	
Output Contact Rating-SPST 111P 233P-1.5 233P 235P	1hp@120VAC (16 amps max.) 1.5hp@240VAC (10 amps max.) 3hp@240VAC (17 amps max.) A300, 720VA@240VAC (10 amps max.)
General Characteristics	
Operating Temperature Maximum Input Power Wire Gauge Terminal Torque Safety Marks: cUL Listed Dimensions Weight Mounting Methods:	-40° to 55° C (-40° to 131° F) 5 W Solid or Stranded 10 - 22AWG 13 in.-lbs. UL508, C22.2 No. 14 2.9" H x 5.25" W x 2.913" D 3 lbs. #8 screws

For a typical wiring diagram see page 31.

For installation instructions see page 32.

For product dimensions see page 54.

How to order:

111P-ENCL (enclosure with 111P mounted)

233P-1.5-ENCL (enclosure with 233P-1.5 mounted)

233P-ENCL (enclosure with 233P mounted)

235P-ENCL (enclosure with 235P mounted)



www.SymCom.com

...your electronic control & protection specialists

(605) 348.5580 / (800) 843.8848 / Fax (605) 348.5685

customerservice@symcom.com / technicalsupport@symcom.com

Metal Box Only - NEMA-3R-L



The NEMA 3R-L enclosure is a metal electrical box that meets the National Electrical Manufacturers Association's standard for a 3R enclosure (rain proof). The NEMA 3R-L box can house several different single-phase SymCom PumpSaver® models. It has two clear lenses on the cover for viewing the LEDs on the PumpSaver®, allowing the customer to determine the units operational status.

The NEMA 3R-L is sold separately.

Specifications

Functional Specifications	
Classification	NEMA 3R standard (rain proof)
Grounding	12" long 12-gauge wire secured by ground screw
General Characteristics	
Dimensions	6" x 6" x 4.5" (4" inside depth)
Front Cover	Secured by two machine screws, contains two clear lenses for viewing LED lights on PumpSaver
Weight	3.3 lbs.
Mounting Method	Surface Mount (four pre-drilled concave holes)
Knock-outs (four)	½" or ¾" (one on each side and two on the bottom)
Security	Padlock tab



www.SymCom.com

...your electronic control & protection specialists

(605) 348.5580 / (800) 843.8848 / Fax (605) 348.5685

customerservice@symcom.com / technicalsupport@symcom.com

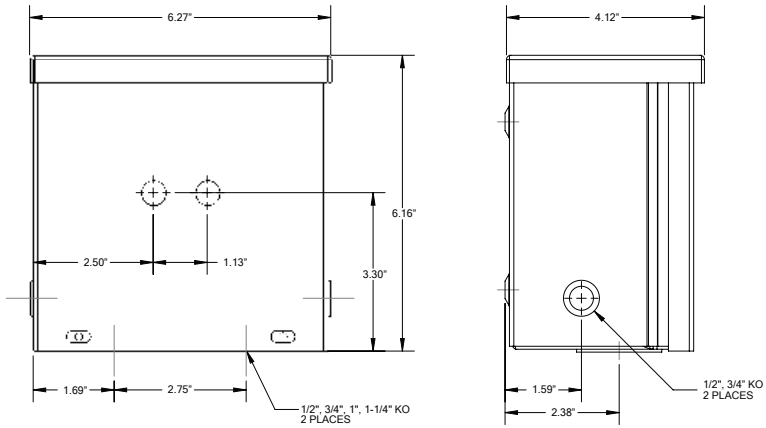

Dimensions NEMA-3R-L

How to order:

NEMA-3R-L (metal box only)

Hand-held Diagnostic Tool - Informer



The Informer is a hand-held diagnostic tool designed for use with single-phase PumpSaver® and PumpSaver®Plus models equipped with infrared LED transmitters.

The Informer uses an infrared receiver to access information sent from the PumpSaver® or PumpSaver®Plus system, which can be helpful for troubleshooting the system.

Each SymCom single-phase PumpSaver® and PumpSaver®Plus model, equipped with an infrared LED, transmits valuable information from the device. To retrieve this information, the Informer's receiver must be directed toward the PumpSaver's LED transmitter and be within 10 feet of the unit. The green COMM STATUS light indicates when the Informer is receiving data from the PumpSaver® or PumpSaver®Plus. If communication is lost, the Informer will display the last values it received. The Informer will automatically shut off after 2 minutes of non-use.

An infrared adapter (IR Kit-12*) is included with all new and updated Informers. This adapter allows communication with the PumpSaver® without opening the panel door.

* 12" fiber optic cable

Specifications

Functional Specifications:	
Communication Signal Range	Infrared 1-10 ft. (0-1 ft when using IR Fiber Optic Kit)
Input Characteristics:	
Power: Consumption: Auto Shut-Off:	9 Volts dc (requires one 9-volt alkaline battery) 0.25 Watt (max.) 2 minutes
Output Characteristics:	
Accuracy: Voltage Current Power Resolution: Voltage Current Power	$\pm 2\%$ $\pm 2\%$ $\pm 4\%$ 1.0VAC 0.1 Amp AC 0.01kW
General Characteristics:	
Operating Temperature: Display: Size: Enclosure Material: Dimensions: Weight:	0° to 60°C (32°F to 140°F) Liquid Crystal 2 rows x 16 characters Black ABS 5.50" H x 3.6" W x 1.125"D 6 oz. (w/o battery)

How to order:

Informer (Hand-held Diagnostic Tool, includes IR Kit-12)



www.SymCom.com

...your electronic control & protection specialists

(605) 348.5580 / (800) 843.8848 / Fax (605) 348.5685

customerservice@symcom.com / technicalsupport@symcom.com

Models 77C-KW/HP / 77C-LR-KW/HP

Input Characteristics	
Supply Voltage Frequency Motor Full Load Amp Range 77C-KW/HP 77C-LR-KW/HP	100-240VAC 50/60Hz 2-25 Amps (Loops Required); 26-90 Amps (Direct); 91-800 Amps (External CTs) 1-2 Amps (1 Loop Required); 2.1-9 Amps (Direct)
Output Characteristics	
Output Contact Rating-SPDT (Form C) Expected Life Mechanical Electrical	480VA@240VAC (Pilot Duty) 10A@240VAC (General Purpose) 1 x 10 ⁶ operations 1 x 10 ⁵ operations at rated load
General Characteristics	
Operating Temperature Ambient Operating Ambient Storage Accuracy Voltage Current Timing Power Repeatability Voltage Current Maximum Input Power Pollution Degree Class of Protection Relative Humidity Safety Marks UL CE Dimensions Weight Mounting Methods	-20° to 70° C (-4° to 158° F) -40° to 80° C (-40° to 176° F) ±1% ±3% (Direct, No External CTs) 5% ± 1 second ± 10% ± 0.5% of nominal voltage ± 1% (Direct, No External CTs) 10 W 3 IP20, NEMA 1 (finger safe) 10-95%, non-condensing per IEC 68-2-3 UL508, UL1053 IEC 60947-1, IEC 60947-5-1 3.0" H x 5.1" D x 3.6" W 1.2 lbs. 35mm DIN rail or surface mount

For a typical wiring diagram see page 36.

For installation instructions see page 37.

For product dimensions see page 55.

How to order:

77C-KW/HP (Programmable Pump Protection)

77C-LR-KW/HP (Low-Range Programmable Pump Protection)



www.SymCom.com

...your electronic control & protection specialists

(605) 348.5580 / (800) 843.8848 / Fax (605) 348.5685

customerservice@symcom.com / technicalsupport@symcom.com

Three-Phase Programmable Overload Relay - Model 777-P2
 Three-Phase Low Range Prog. Overload Relay - Model 777-LR-P2
 Three-Phase High Voltage Prog. Pump Protection - Model 777-HVR-P2



The Model 777-P2 Series is a family of fully programmable electronic overload relays. They are designed to monitor and protect any 3-phase 200-480VAC motor drawing 2-800 full load amps (external CTs are required above 90 amps). They provide unsurpassed protection from faulty voltage, underload and overload conditions. The 777-P2 can be used in a variety of 3-phase applications and features an undercurrent trip point (adjustable on the unit) that is favorable anytime there is a notable difference between a load and no-load condition. The overload relay displays voltage and current on the face of the unit. The LR version is designed for easier installation at a lower range of 1-9 full load amps. The HVR version is designed with a high voltage relay for control circuits operating at 480VAC.

The 777-P2 Series units incorporate a 3-digit LED display that is used for programming, providing real-time operational information, and displaying diagnostic codes to aid in troubleshooting a fault condition.

The unit's many features include enhanced trip classes beyond the NEMA standard trip classes. The settable trip class range is 2-60, with or without jam protection, and a secondary linear trip delay can be set with a range of 0-60 seconds. If both trip class and linear trip delay are set, the 777-P2 will follow the faster trip time. Another feature is the automatic dry-well recovery timer that allows the unit to automatically select a restart delay based on the last cycle's run time. This allows the 777-P2 to optimize restart delay times.

Specifications

Functional Specifications	
Programmable Operating Points LV-Low Voltage Threshold HV-High Voltage Threshold VUB-Voltage Unbalance Threshold MULT-# of Conductors of CT Ratio (xxx:5) OC-Overcurrent Threshold UC-Undercurrent Threshold CUB-Current Unbalance Threshold TC-Overcurrent Trip Class RD1-Rapid-cycle Timer RD2-Restart Delay after all faults except undercurrent (motor cool down timer) RD3-Restart Delay after undercurrent (dry-well recovery timer) #RU-Number of restarts after undercurrent ADDR-RS485 Address #RF-Number of Restarts after all faults except undercurrent COM-Communication setting UCTD-Undercurrent Trip Delay GF-Ground Fault Current Threshold	170-524V 172-528V 2-25% or 999 (disable) 1-10, 100, 150, 200, 300, 400, 500, 600, 700, 800 (20-100A) + MULT or 80-140% of CT Primary (0, 10-98A) + MULT or 40-140% of CT Primary 2-50% or 999 (disable) 2-60, J2-J60, L00-L60, oFF 0-999 seconds 2-500 minutes 2-500 minutes, A (automatic) 0, 1, 2, 3, 4, A (automatic) A01-A99 0, 1, oc1, 2, oc2, 3, oc3, 4, oc4, A, ocA (automatic) C00-C07 2-999 seconds (3-20A) + MULT or 12-40% of CT Primary or oFF

Models 777-P2 / 777-LR-P2 / 777-HVR-P2

Input Characteristics	
Supply Voltage 777-P2, 777-LR-P2 777-HVR-P2	200-480VAC 340-480VAC
Frequency	50/60Hz
Motor Full Load Amp Range 777-P2, 777-HVR-P2 777-LR-P2	2-20 Amps (Loops Required); 20-90 Amps (Direct); 80-800 Amps (External CTs) 1-9 Amps; 10-800 Amps (External CTs)
Output Characteristics	
Output Contact Rating-SPDT (Form C) 777-P2, 777-LR-P2 777-HVR-P2	480VA@240VAC (Pilot Duty) 10A@240VAC (General Purpose) 470VA@600VAC
Expected Life Mechanical Electrical	1 x 10 ⁶ operations 1 x 10 ⁵ operations at rated load
General Characteristics	
Operating Temperature Ambient Operating Ambient Storage	-20° to 70° C (-4° to 158° F) -40° to 80° C (-40° to 176° F)
Accuracy Voltage Current Timing Power	±1% ±3% (Direct, No External CTs) 5% ± 1 second ± 10%
Repeatability Voltage Current	± 0.5% of nominal voltage ± 1% (Direct, No External CTs)
Maximum Input Power	10 W
Pollution Degree	3
Class of Protection	IP20, NEMA 1 (finger safe)
Relative Humidity	10-95%, non-condensing per IEC 68-2-3
Safety Marks UL CE	UL508, UL1053 IEC 60947-1, IEC 60947-5-1
Dimensions	3.0" H x 3.6" W x 5.1" D
Weight	1.2 lbs.
Mounting Methods	35mm DIN rail or surface mount

For a typical wiring diagram see page 41-42.

For installation instructions see page 43.

For product dimensions see page 55.

How to order:

777-P2 (Programmable Overload Relay)

777-LR-P2 (Low-Range Programmable Overload Relay)

777-HVR-P2 (High Voltage Relay Prog. Overload Relay)



www.SymCom.com

...your electronic control & protection specialists

(605) 348.5580 / (800) 843.8848 / Fax (605) 348.5685

customerservice@symcom.com / technicalsupport@symcom.com

3-Phase Programmable Pump Protection - Model 777-KW/HP-P2
 3-Phase Low-Range Prog. Pump Protection - Model 777-LR-KW/HP-P2
 3-Phase Med-Low Range Pump Protection - Model 777-MLR-KW/HP-P2
 3-Phase High Voltage Pump Protection - Model 777-HVR-KW/HP-P2



The Model 777-KW/HP-P2 Series is a family of fully programmable electronic power monitors. They are designed to monitor and protect any 3-phase 200-480VAC motor drawing 2-800 full load amps (external CTs are required above 90 amps). They provide unsurpassed protection from faulty voltage, underload and overload conditions. The 777-KW/HP-P2 can be used in a variety of 3-phase applications and features a low power trip point (adjustable on the unit) that is desirable any time the current vs. load characteristic is non-linear or has little change. In general, this applies to small slow speed motors, small centrifugal motors and fractional horsepower motors. Low power protection can be used any time in place of undercurrent protection. The power monitor displays kilowatts and horsepower on the face of the unit. The LR version is designed for easier installation at a lower range of 1-9 full load amps. The HVR version is designed with a high voltage relay for control circuits operating at 480VAC.

The 777-KW/HP-P2 Series units incorporate a 3-digit LED display that is used for programming, providing real-time operational information, and displaying diagnostic codes to aid in troubleshooting a fault condition.

The unit's many features include enhanced trip classes beyond the NEMA standard trip classes. The settable trip class range is 2-60, with or without jam protection, and a secondary linear trip delay can be set with a range of 0-60 seconds. If both trip class and linear trip delay are set, the 777-KW/HP-P2 will follow the faster trip time. Another feature is the automatic dry-well recovery timer that allows the unit to automatically select a restart delay based on the last cycle's run time. This allows the 777-KW-HP-P2 to optimize restart delay times.

Specifications

Functional Specifications	
Programmable Operating Points (on face of the units)	
LV-Low Voltage Threshold	170-524V
HV-High Voltage Threshold	172-528V
VUB-Voltage Unbalance Threshold	2-25% or 999 (disable)
MULT-# of Conductors or CT Ratio (xxx:5)	1-10, 100, 150, 200, 300, 400, 500, 600, 700, 800 (20-100A) + MULT or 80-140% of CT Primary
OC-Overcurrent Threshold	1=0.01-0.99kW 5=0.01-1.32hp 2=1.00-9.95kW 6=1.34-13.3hp 3=10.0-99.5kW 7-13.4-133hp 4=100-650kW 8=134-871hp
PWS-Power Scale	0.01-650kW or 0.01-871hp; LP setting is dependent on PWS setting. PWS setpoint must be programmed prior to LP
LP-Low Power	2-50% or 999 (disable)
CUB-Current Unbalance Threshold	2-60, J2-J60, L00-L60, oFF
TC-Overcurrent Trip Class	0-999 seconds
RD1-Rapid-cycle Timer	2-500 minutes
RD2-Restart Delay after all faults except underload (motor cool-down timer)	
RD3-Restart Delay after underload (dry-well recovery timer)	2-500 minutes, A (automatic)
#RU-Number of Restarts after underload	0, 1, 2, 3, 4, A (automatic)
ADDR-RS485Address	A01-A99
#RF-Number of Restarts after all faults except underload	0, 1, oc1, 2, oc2, 3, oc3, 4, oc4, A, ocA (automatic)
COM-Communication setting	C00-C07
GF-Ground Fault Current Threshold	(3-20A) ÷ MULT of 12-40% of CT Primary or oFF



www.SymCom.com

...your electronic control & protection specialists

(605) 348.5580 / (800) 843.8848 / Fax (605) 348.5685
 customerservice@symcom.com / technicalsupport@symcom.com

Models 777-KW/HP-P2 / 777-LR-KW/HP-P2 / 777-MLR-KW/HP-P2
777-HVR-KW/HP-P2

Input Characteristics	
Supply Voltage 777-KW/HP-P2, 777-LR-KW/HP-P2, 777-MLR-KW/HP-P2 777-HVR-KW/HP-P2	200-480VAC 340-480VAC
Frequency	50/60Hz
Motor Full Load Amp Range 777-KW/HP-P2, 777-HVR-KW/HP-P2 777-LR-KW/HP-P2 777-MLR-KW/HP-P2	2-20 Amps (Loops Required); 20-90 Amps (Direct); 80-800 Amps (External CTs) 1-2 Amps (1 Loop Required); 2.1-9 Amps (Direct); 10-800 Amps (External CTs) 0.5-10.5 Amps (Loops Required), 5-21 (Direct), 40-740 (External CTs)
Output Characteristics	
Output Contact Rating-SPDT (Form C) 777-KW/HP-P2, 777-LR-KW/HP-P2, 777-MLR-KW/HP-P2 777-HVR-KW/HP-P2	480VA@240VAC (Pilot Duty) 10A@240VAC (General Purpose) 470VA@600VAC
Expected Life Mechanical Electrical	1 x 10 ⁶ operations 1 x 10 ⁵ operations at rated load
General Characteristics	
Operating Temperature Ambient Operating Ambient Storage	-20° to 70° C (-4° to 158° F) -40° to 80° C (-40° to 176° F)
Accuracy Voltage Current Timing Power	±1% ±3% (Direct, No External CTs) 5% ± 1 second ± 10%
Repeatability Voltage Current	± 0.5% of nominal voltage ± 1% (Direct, No External CTs)
Maximum Input Power	10 W
Pollution Degree	3
Class of Protection	IP20, NEMA 1 (finger safe)
Relative Humidity	10-95%, non-condensing per IEC 68-2-3
Safety Marks UL CE	UL508, UL1053 IEC 60947-1, IEC 60947-5-1
Dimensions	3.0" H x 3.6" W x 5.1" D
Weight	1.2 lbs.
Mounting Methods	35mm DIN rail or surface mount

For a typical wiring diagram see page 41-42.

For installation instructions see page 43.

For product dimensions see page 55.

How to order:

777-KW/HP-P2 (Programmable Pump Protection)

777-LR-KW/HP-P2 (Low-Range Programmable Pump Protection)

777-MLR-KW/HP-P2 (Medium-Low Range Programmable Pump Protection)

777-HVR-KW/HP-P2 (High Voltage Relay Programmable Pump Protection)



www.SymCom.com

...your electronic control & protection specialists

(605) 348.5580 / (800) 843.8848 / Fax (605) 348.5685

customerservice@symcom.com / technicalsupport@symcom.com

Liquid Level Sensor - Model 460-15-100-LLS



The PumpSaver® Model 460-15-100-LLS is a liquid level sensor to detect the presence of conductive liquids. The unit has an adjustable debounce timer (2-60 seconds) to help prevent nuisance relay actuations due to waves or liquid splashing into the tank. When the probe (user supplied) is submersed, the PumpSaver's output contacts will change state as soon as the debounce time expires.

Relay logic can be inverted so the PumpSaver's output contacts change state when the probe is no longer submersed.



Specifications

Functional Specifications	
Sensitivity	100k Ω
Debounce Time	2 - 60 seconds
Input Characteristics	
Control Voltage	110/120VAC nominal
Frequency	50/60Hz (Note: 50Hz will increase all delay timers by 20%)
Output Characteristics	
Output Contact Rating-DPST	360VA@240VAC (Pilot Duty) 8A@240VAC (General Purpose)
General Characteristics	
Operating Temperature	-20° to 70° C (-4° to 158° F)
Maximum Input Power	2 W
Relative Humidity	10-95%, non condensing per IEC 68-2-3
Terminals	
Wire Size	12-20 AWG
Torque	6 in.-lbs.
Class of Protection	IP20, NEMA 1 (finger safe)
Safety Marks	
cUL	UL508, C22.2 No. 14
Dimensions	3.5" L x 2.084" W x 2.35" H
Weight	9 oz.
Mounting Method	35 mm DIN rail or Surface Mount (#6 or #8 screws)

For a typical wiring diagram see page 51.

For product dimensions see page 56.

How to order:

460-15-100-LLS (Liquid Level Sensor)



www.SymCom.com

...your electronic control & protection specialists

(605) 348.5580 / (800) 843.8848 / Fax (605) 348.5685

customerservice@symcom.com / technicalsupport@symcom.com

Liquid Level Controllers - Models PC-xxx-LLC-CZ / PC-xxx-LLC-GM



The PC-xxx-LLC-CZ & PC-xxx-LLC-GM are liquid level control relays used to control conductive liquid pumping operations in a pump-up or pump-down application. The units come in two different voltage ranges (see specs on adjacent page).

The units have an adjustable sensitivity knob (4.7k to 100k ohms) that is set according to the resistance level at which you want the probes (user supplied) to sense the conductive liquid. The units have a built-in debounce time delay that prevents the relay from energizing if the probe resistance momentarily goes above or below the sensitivity setpoint (due to liquid splashing in the tank).

The units operate their internal relay based on inputs from a high and low probe and a common reference (when a conductive tank is used) or common probe (when a non-conductive tank is used).

PC-xxx-LLC-GM

- Compatible with Gems' Series 16M general purpose control
(Direct replacement for GEMS models: 16MA1A0, 16MB1A0, 16MC1A0, 16MD1A0, 16ME1A0, 16MA2A0, 16MB2A0, 16MC2A0, 16MD2A0, 16ME2A0, 16MK1A0, 16ML1A0, 16MM1A0, 16MN1A0, 16MP1A0, 16MK2A0, 16MM2A0, 16MN2A0, 16MP2A0)

PC-xxx-LLC-CZ

- Compatible with Crouzet's PNR & PNRU series liquid level control
(Direct replacement for Crouzet models: PNR110A, PNR220A, PNRU110A, PNRU220A)



www.SymCom.com

... your electronic control & protection specialists

(605) 348.5580 / (800) 843.8848 / Fax (605) 348.5685
customerservice@symcom.com / technicalsupport@symcom.com

Specifications

Functional Characteristics	
Debounce Time Delay Probe Sensitivity	2 second 4.7k to 100k Adjustable
Input Characteristics	
Supply Voltage PC-100-LLC-CZ, PC-100-LLC-GM PC-200-LLC-CZ, PC-200-LLC-GM Frequency Probe Sense Voltage	95-120VAC 190-240VAC 50/60 Hz (note: 50Hz will increase all delay timers by 20%) 5vdc pulsed
Output Characteristics	
Output Contact Rating Pilot Duty General Purpose	480VA @ 240VAC 10A @ 240VAC
General Characteristics	
Ambient Operating Temperature Maximum Input Power Relative Humidity Terminal Torque Wire Gauge Safety Marks UL listed (OT08 octal socket required) CE Dimensions Weight Enclosure Mounting Method	-40° to 70° C (-40° to 158° F) 5 W 10-95%, non-condensing per IEC 68-2-3 12 in.-lbs. 12-22 AWG Solid or stranded UL508 (File #E68520) IEC 60947-6-2 1.750" H x 2.375" W x 4.125" D (with socket) 9 oz. Polycarbonate Plugs into 8-Pin OT08 Socket; DIN Rail or surface mount

For a typical wiring diagram see page 52-53.
For product dimensions see page 56.

How to order:

PC-100-LLC-CZ
PC-200-LLC-CZ
PC-100-LLC-GM
PC-200-LLC-GM



www.SymCom.com

...your electronic control & protection specialists

(605) 348.5580 / (800) 843.8848 / Fax (605) 348.5685
customerservice@symcom.com / technicalsupport@symcom.com

(PENTEK® CONTROL BOX / FRANKLIN™ CONTROL BOX)
 1/3 - 1/2hp, 115VAC - 111-Insider-P / 1/3 - 1hp, 230VAC - 231-Insider-P
 TYPICAL WIRING DIAGRAM

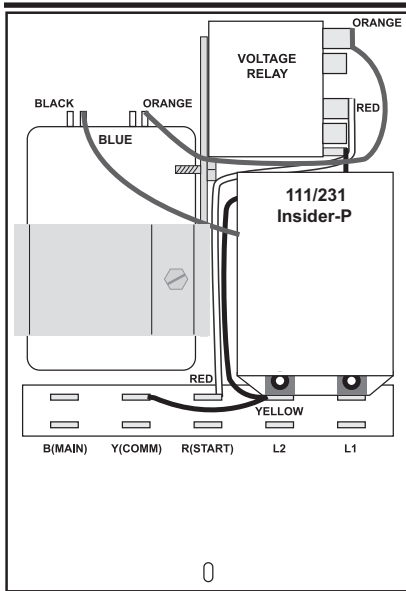

111-Insider-P/231-Insider-P
 in Pentek® Control Box

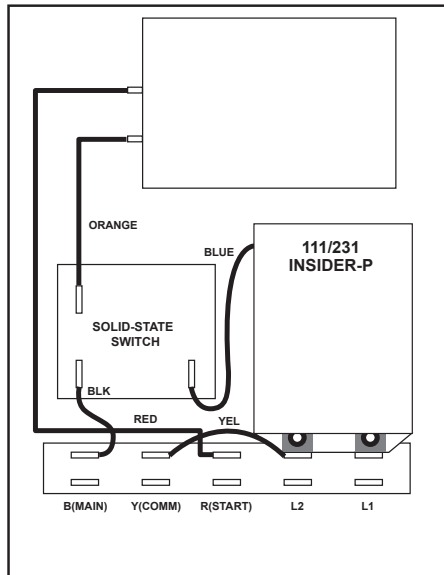

111-Insider-P/231-Insider-P
 in Franklin™ Control Box

(CENTRIPRO™ CONTROL BOX)
1/3 - 1/2hp, 115VAC - 111-Insider-P / 1/3 - 1hp, 230VAC - 231-Insider-P
TYPICAL WIRING DIAGRAM

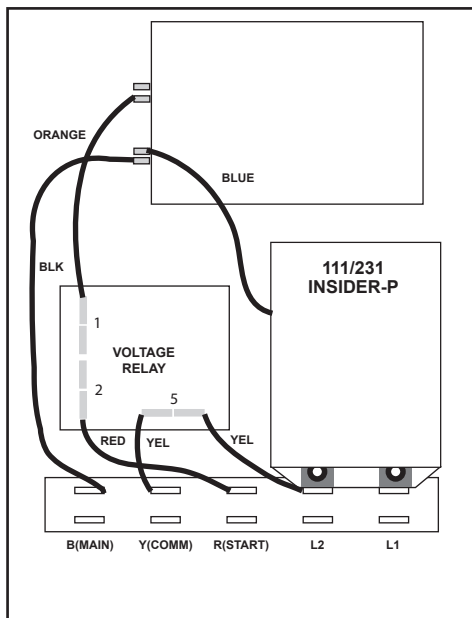

111-Insider-P/231-Insider-P
in CentriPro™ Control Box

Grundfos® control box, 1/3 - 1hp, 230VAC - Model 232-Insider
 Grundfos® control box, 1/3 - 3hp, 230VAC - Model 234-P
 TYPICAL WIRING DIAGRAM

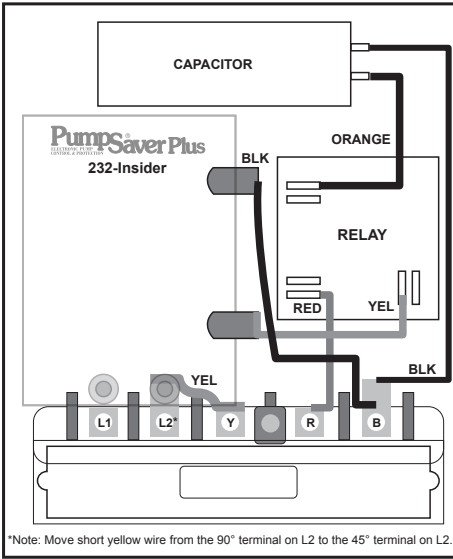

232-Insider
 in Grundfos® Control Box

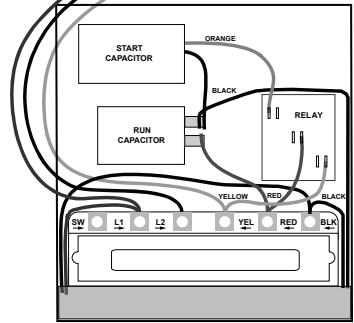
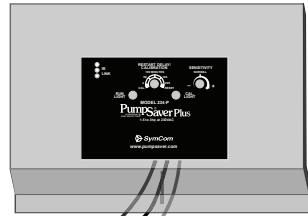

234-P
 in Grundfos® Control Box

(not recommended for use with Grundfos®
 Deluxe Control Box)

$\frac{1}{3}$ - 1hp, 115VAC - 111P
 $\frac{1}{3}$ - 1.5hp, 230VAC - Model 233P-1.5 / $\frac{1}{3}$ - 3hp, 230VAC - 233P
 5 - 15, 230VAC - Model 235P
TYPICAL WIRING DIAGRAM

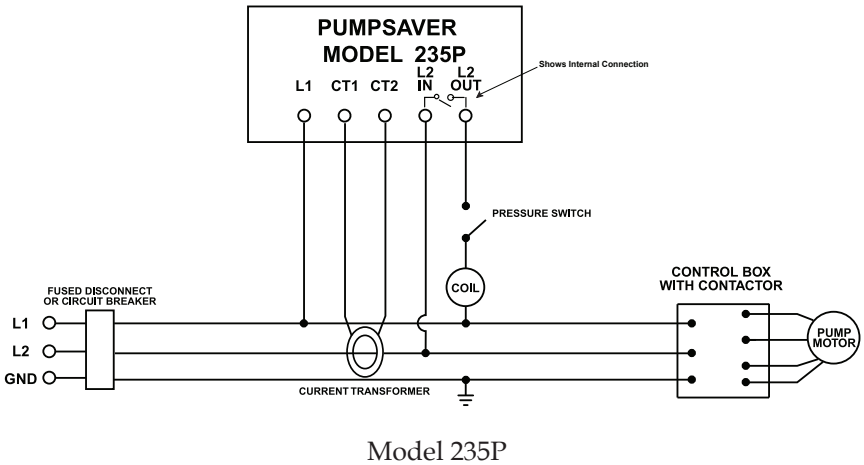
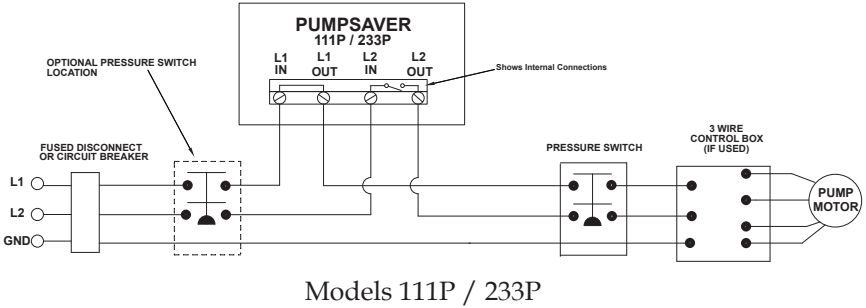

Size	Current	CT*
5 - 7½ HP	27.5 - 42.1	50:5
10 HP	51	75:5
15 HP	75	100:5

* external current transformers sold separately



www.SymCom.com

...your electronic control & protection specialists

(605) 348.5580 / (800) 843.8848 / Fax (605) 348.5685

customerservice@symcom.com / technicalsupport@symcom.com

PUMPSAVER®PLUS

INSTALLATION INSTRUCTIONS

The PumpSaver®Plus INSIDERS fit inside 1/3 – 3hp, 230V Franklin™, Pentek®, Grundfos® or CentriPro™ control boxes. PumpSavers are designed to protect single-phase pumps from dry-well, dead-head, rapid-cycling, jammed impeller, and over/undervoltage conditions. Typical applications include residential waterwells, commercial waterwells, irrigation wells, and golf course and other sprinkler systems.

CONNECTIONS

(INSIDERS)

Refer to specific connection instructions depending on the particular control box being used:

Grundfos® control box	- page 30
Pentek® control box	- page 28
Franklin™ control box	- page 28
CentriPro™ control box	- page 29

(111P / 233P / 235P)

NOTE: Use in conjunction with UL listed or recognized thermal or solid-state overload relays only.

1. Mount the PumpSaver®Plus Model 111P / 233P / 235P in a convenient location in or near the pump control box. If the location is wet or dusty, a NEMA 3R, 4 or 12 enclosure should be used.
2. Refer to Typical Wiring Diagram for 111P / 233P / 235P on page 31.

NOTE: For Model 235P, one line from the fused disconnect must pass through the current transformer.

The Model 235P will NOT function without an external CT (sold separately).

NOTE: If the Model 235P immediately trips out upon completion of the calibration process, the current transformer may be installed incorrectly. Switch the CT1 and CT2 connections at the unit, then repeat the calibration process.

CALIBRATION / RESTART DELAY

NOTE: All PumpSaver®Plus models should be calibrated during normal pumping conditions.

(INSIDERS)

1. Turn RESTART DELAY/CALIBRATION to the CAL position and close the box cover.
2. Apply power to the system. The pump should run for approximately 10 seconds and then shut off – this indicates the INSIDER has calibrated.
3. Remove power from the system. Open the control box and set the appropriate dry-well recovery time with the RESTART DELAY / CALIBRATION knob.
4. Shut the control box and re-apply power to the system.

(111P / 233P / 235P)

1. Turn the RESTART DELAY/CALIBRATION knob fully counter-clockwise to the CAL. position.
2. Apply power- the pump will run for approximately 10 seconds then shut off.
3. Set the RESTART DELAY/CALIBRATION knob to the desired restart delay (dry-well recovery time) - the pump will turn on.

CALIBRATING WHILE PUMPING

The Model 111P / 233P / 235P can also be calibrated while the pump is running. Turn the RESTART DELAY/CALIBRATION knob to CAL. while pumping. Wait for the pump to turn off (approximately 10 seconds), then adjust the RESTART DELAY/CALIBRATION knob to the desired setting.



www.SymCom.com

...your electronic control & protection specialists

(605) 348.5580 / (800) 843.8848 / Fax (605) 348.5685

customerservice@symcom.com / technicalsupport@symcom.com

PUMPSAVER®PLUS INSTALLATION INSTRUCTIONS

MANUAL RESET MODE (111P / 233P / 235P only)

Set the RESTART DELAY/CALIBRATION knob to RESET for manual reset mode. If the 111P / 233P / 235P trips off due to a voltage or load problem, the RESTART DELAY/CALIBRATION knob must be rotated out of the RESET position to restart the pump, and then can be placed back in the RESET position for subsequent manual reset mode.

NOTE: Any restart delay can be bypassed by rotating the RESTART DELAY/CALIBRATION knob to the RESET position and back to the desired restart delay setting.

NOTE: The restart delay can be changed at any time. The next trip will follow the new restart delay setting.

OPERATION

The PumpSaver®Plus units monitor pump loads in amps and kilowatts. When the current (amps) exceeds approximately 125% of calibrated current, or power (kW) drops below the adjustable underload trip point, the PumpSaver®Plus units –after the trip delay– will turn off the pump. The PumpSaver®Plus units will automatically restart the pump after the selected restart delay time (unless in the manual reset mode).

The calibration is stored in permanent memory. The PumpSaver®Plus does not need to be recalibrated if power is lost.

SENSITIVITY

The PumpSaver®Plus units have an adjustment knob to set the underload trip sensitivity. Setting SENSITIVITY to the middle position (straight up) is equivalent to SymCom's standard underload trip level. Adjust the SENSITIVITY knob to increase/decrease underload sensitivity up to approximately $\pm 10\%$ of the standard trip. It may be necessary to increase the sensitivity if the PumpSaver®Plus does not trip on dry-run or dead-head or it is known that the water level in the well is very low relative to the pump's capabilities.

WARNING: Decreasing the SENSITIVITY may compromise the PumpSaver's ability to detect dry-run and/or dead-head conditions.

RUN HOURS

The PumpSaver®Plus units record pump run hours. Run hours can be displayed by a PumpSaver® Informer. Run hours can be reset on the PumpSaver®Plus units. –please read the instruction fully before performing the procedure.

NOTE: Turn the SENSITIVITY knob completely to the left (counter-clockwise) or completely to the right (clockwise) when directed.

WARNING: ENSURE POWER IS APPLIED TO THE INSIDERS IN A SAFE MANNER WHEN PERFORMING THE FOLLOWING PROCEDURE.

To Reset Run Hours:

1. Remove power to the PumpSaver®Plus.
2. Set the RESTART DELAY/CALIBRATION knob to RESET and the SENSITIVITY knob to the middle (12:00) position.
3. Apply power to the PumpSaver®Plus –the CAL. LIGHT will turn on.
4. Turn the SENSITIVITY knob to the right –the CAL. LIGHT will turn off and the RUN LIGHT



www.SymCom.com

...your electronic control & protection specialists

(605) 348.5580 / (800) 843.8848 / Fax (605) 348.5685
customerservice@symcom.com / technicalsupport@symcom.com

PUMPSAVER®PLUS

INSTALLATION INSTRUCTIONS

will turn on.

5. Turn the SENSITIVITY knob to the left – both lights will turn on.
6. Turn the SENSITIVITY knob to the right.
7. After 10 seconds, the CAL. and RUN LIGHTS will blink twice indicating the run hours have successfully been reset.

RAPID CYCLING

Rapid cycling is defined as more than 4 restarts in a 60-second period. The PumpSaver®Plus is capable of detecting a rapid-cycle condition whether a control device, such as a pressure switch, is installed before* or after it. Upon detecting either form of rapid cycling, the PumpSaver®Plus will lock-out, preventing damage to the pump. To reset the PumpSaver®Plus, remove and re-apply power.

RAPID CYCLING (Line Side / Upstream)

Rapid cycling of the line side of the PumpSaver®Plus may be caused by several naturally occurring conditions which are indistinguishable from true rapid cycling. For this reason, once tripped, Symcom's protection will wait 30 minutes and restart. If any restart is successful (pump runs for more than 1 minute), the rapid cycle counter will reset to zero. If the PumpSaver®Plus encounters rapid cycle 4 times without a successful restart, the PumpSaver®Plus will lock-out and require a manual reset. To reset the PumpSaver®Plus, remove and re-apply power.

*Protection against rapid cycling of a control device installed before the PumpSaver®Plus is disabled by default. Read the following instructions fully before performing the procedure to enable this feature.

NOTE: Turn the SENSITIVITY knob completely to the left (counter-clockwise) or completely to the right (clockwise) when directed.

To Enable Line-Side Rapid-Cycle Protection: (to disable, follow the same procedure and replace the jumper on the PumpSaver®Plus) (Insiders only)

1. Locate the Rapid-Cycle Jumper in the upper-right corner behind the faceplate of the PumpSaver®Plus.
2. Remove the Rapid-Cycle Jumper. The jumper may be removed before or after initial installation.
3. Save the removed jumper.
4. If the PumpSaver®Plus is not already installed, install as described in the CONNECTIONS section.
5. Re-apply power.

To Enable Rapid-Cycle Protection when a Control Device is Installed BEFORE the PumpSaver®Plus: (to disable, follow the same procedure)

1. Remove power to the PumpSaver®Plus.
2. Set the RESTART DELAY / CALIBRATION knob to RESET and the SENSITIVITY knob to the middle (12:00) position.
3. Apply power to the PumpSaver®Plus – the CAL. LIGHT will turn on.
4. Turn the SENSITIVITY knob to the right – the CAL. LIGHT will turn off, RUN LIGHT will turn on.
5. Turn the SENSITIVITY knob to the left – both lights will turn on.
6. Turn the SENSITIVITY knob right – left – right – left – right.
7. After 2 seconds, the CAL. and RUN LIGHTS will blink once indicating line side rapid-cycle protection has been enabled.



www.SymCom.com

...your electronic control & protection specialists

(605) 348.5580 / (800) 843.8848 / Fax (605) 348.5685
customerservice@symcom.com / technicalsupport@symcom.com

PUMPSAVER®PLUS INSTALLATION INSTRUCTIONS

RAPID CYCLING (Load Side / Downstream)

Load side rapid cycling of the pump will immediately result in a manual lock-out. The pump will not restart automatically. To reset the PumpSaver®Plus, remove and re-apply power.

Note: Protection against rapid cycling of a control device installed after the PumpSaver®Plus is always enabled. Disabling line side detection will not disable load side detection.

USING AN INFORMER

The PumpSaver®Plus units are equipped with an infrared LED that will communicate to a SymCom Informer—a hand-held, battery operated, diagnostic tool. An Informer IR Kit fiber optic cable is required for the PumpSaver®Plus Insider units to communicate to the Informer. The Informer will display the model number; run time; pump starts; restart delay setting; restart delay timer; real-time voltage, current and power; dry-well and overload trip points; calibration voltage; last 20 faults; voltage, current, power and run time for the last 20 faults; highest/lowest voltage and current since calibration; and the CT size if applicable. The Informer can be used on any single-phase PumpSaver®Plus equipped with an infrared LED transmitter—Models 111-Insider-P; 231-Insider-P; 232-Insider; 111P; 233P; 234-P and 235P.

INFORMER TROUBLESHOOTING GUIDE

The Informer does not activate when the ON button is pressed.	Battery Polarity Reversed - Verify the + and - terminals on the battery match the markings inside the battery compartment.
	Low Battery - Replace the battery.
The COMM STATUS light is off and all display values remain at zero.	Weak Signal - Ensure the Informer is aimed directly at the PumpSaver's infrared LED and is within the operating distance.
	PumpSaver®Plus not transmitting - Verify the PumpSaver®Plus is energized and the green RUN light is illuminated.
The COMM STATUS light is blinking.	Sunlight - Verify the sun is not shining directly onto the Informer's infrared receiver.
	Weak Signal - Ensure the Informer is aimed directly at the PumpSaver's infrared LED and is within the operating distance. OR If using an older Informer (version 1.xx or earlier) with a PumpSaver®Plus, this is a normal condition.
The displayed values fluctuate radically.	Weak Signal - Ensure the Informer is aimed directly at the PumpSaver's infrared LED and is within the operating distance.
The Informer displays values even after communication is lost.	This Is Normal - The Informer holds the last values it received before communication was lost. (until the auto shut off)



www.SymCom.com

...your electronic control & protection specialists

(605) 348.5580 / (800) 843.8848 / Fax (605) 348.5685

customerservice@symcom.com / technicalsupport@symcom.com

Programmable Pump Protection - Model 77C-KW/HP
 Low-Range Programmable Pump Protection - Model 77C-LR-KW/HP
TYPICAL WIRING DIAGRAM

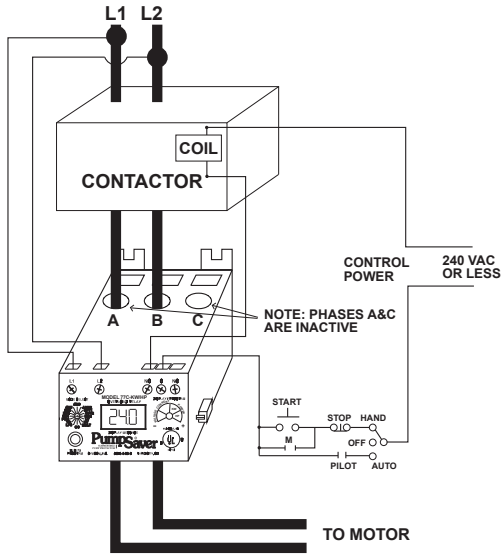

Figure 1: Typical Wiring Diagram for 77C-KW/HP

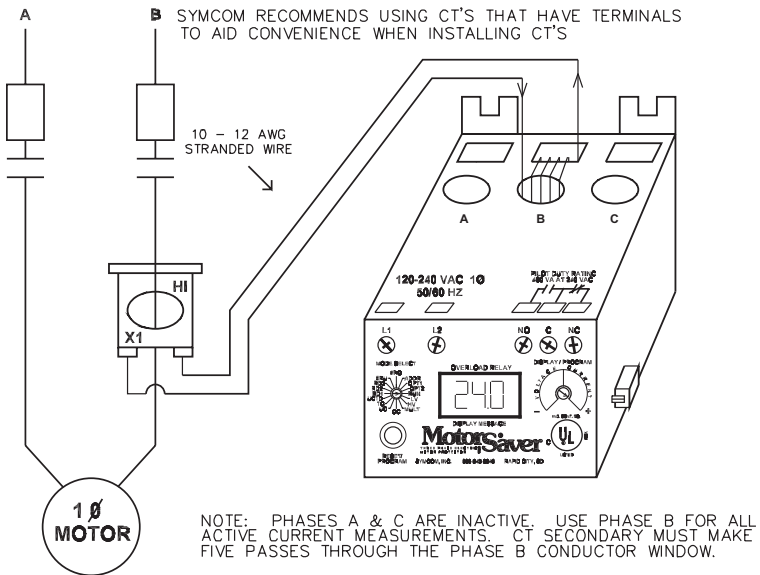

Figure 2: Typical Wiring Diagram for 77C-KW/HP



www.SymCom.com

...your electronic control & protection specialists

(605) 348.5580 / (800) 843.8848 / Fax (605) 348.5685

customerservice@symcom.com / technicalsupport@symcom.com

Programmable Pump Protection - Model 77C-KW/HP

Low-Range Programmable Pump Protection - Model 77C-LR-KW/HP

INSTALLATION INSTRUCTIONS

Full Load Amps	# of Conductors through B	MULT to Program (CT ratio)
2.0 - 2.5	10	10
2.6 - 3.0	9	9
3.1 - 3.5	8	8
3.6 - 4.0	7	7
4.1 - 5.0	6	6
5.1 - 6.0	5	5
6.1 - 8.0	4	4
8.1 - 12	3	3
13 - 25	2	2
26 - 90	1	1
External CTs required. See Wiring Diagram for External CTs.		
91 - 110	5	100 (100:5)
111 - 160	5	150 (150:5)
161 - 220	5	200 (200:5)
221 - 320	5	300 (300:5)
321 - 420	5	400 (400:5)
421 - 520	5	500 (500:5)
521 - 620	5	600 (600:5)
621 - 800	5	800 (800:5)

Table 1: Wiring configuration for 77C-KW/HP based on motor amps.

Full Load Amps	# of Conductors through Window B	MULT
1.0 - 2.0	2	2
2.1 - 9.0	1	1

Table 2: Wiring configuration for 77C-LR-KW/HP based on motor amps.

PROGRAMMING

1. Rotate the MODE SELECT switch to the parameter to be programmed. It is recommended that PWS be programmed first on the KW/HP versions.
2. Press and hold the RESET/PROGRAM button.
3. While holding the RESET/PROGRAM button, rotate the DISPLAY/PROGRAM knob until the proper setting for the parameter that is being programmed is displayed.
4. Release the RESET/PROGRAM button. This stores the new parameter in the nonvolatile memory. If the number changes back to what it was before programming, then the tamper guard is on and will need to be unlocked before programming can be completed.
5. Continue steps 1-4 until all parameters are programmed.

SUGGESTED SETTINGS (Consult the Motor Manufacturer for their recommendations.)

LV/HV- The recommended settings for LV (low voltage) and HV (high voltage) depend on many factors such as motor usage, motor size, environmental factors and tolerance of the motor. The motor manufacturer should be consulted for HV and LV settings. However, the NEMA MG1 standard recommends that LV and HV be set to no more than $\pm 10\%$ of the motor's nameplate voltage. The setting can be determined by multiplying the motor's nameplate voltage by the recommended percent over and under voltage. (eg., The motor nameplate voltage is 230 V, set LV to $0.9 \times 230 = 207$, set HV to $1.10 \times 230 = 253$) LV can not be set



www.SymCom.com

...your electronic control & protection specialists

(605) 348.5580 / (800) 843.8848 / Fax (605) 348.5685

customerservice@symcom.com / technicalsupport@symcom.com

Programmable Pump Protection - Model 77C-KW/HP

Low-Range Programmable Pump Protection - Model 77C-LR-KW/HP

INSTALLATION INSTRUCTIONS

higher than HV, so HV may have to be adjusted higher before the proper LV setting can be programmed.

MULT- MULT is the multiplication factor for determining true current settings and represents the number of conductors passing through the main current window marked B, or current transformer ratio of external CTs. The appropriate number can be determined from Table 1 (Table 2 for -LR version) on page 37. MULT must be correctly programmed in order to accurately program the current settings.

OC- Represents the motor's maximum service factor amperage. The OC (overcurrent) setting depends on many factors such as motor usage, motor size, environmental factors and tolerance of the motor. The motor manufacturer should be consulted for OC settings. However, OC is typically between 110% and 125% of full load amperage (FLA) and may be referred to as maximum amps.

LP- LP (low power setting) is used to shut down the motor or pump on an underload condition. Setting LP to 0 disables the underload trip feature. LP is set in either kilowatts (KW) or horsepower (HP) depending on the PWS setting. **NOTE: PWS must be set before setting LP**

TC- TC designates the trip class for overload protection. The trip class defines the trip delay when an overload is detected. Trip class is determined by the type of motor and application. Your motor manufacturer should be consulted for the proper setting. Table 4 shows the trip class and a general description of the applications and Table 5 shows the trip class curves.

RD1- RD1 is the rapid-cycle timer. It will engage when the motor is first powered-up or after the motor controls shut down the motor. An RD1 setting of 20-30 seconds will generally protect the motor from rapid, successive power outages or short cycling caused by the motor controls. A setting of 0 seconds will allow the motor to start immediately after power-up or after a normal shutdown.

RD2- RD2 is the restart delay after the overload relay trips on overload. This delay allows the motor to cool down after experiencing an overcurrent. It is also known as a motor cool down timer. Your motor manufacturer should be contacted to determine this setting. Under normal circumstances, a setting of 5-10 minutes will give the motor enough time to cool down between faults.

RD3- RD3 is the restart delay after an underload. It is also known as a dry well recovery timer and is usually used in submersible pumping applications. The setting of RD3 depends on the recovery time of the water well and varies widely from application to application.

#RU- #RU is the number of successive restart attempts allowed after an underload fault, before the overload relay requires manual reset. The following settings are available: 0, 1, 2, 3, 4 and A. A setting of "0" is manual reset and a setting of A is continuously automatic reset.

ADDR- ADDR is the address setting for RS485 communications. Available settings are from A01 - A99. You may ignore this setting if RS485 communications are not used.

#RO- #RO is the number of successive restart attempts allowed after an overcurrent fault. The following settings are available: 0, 1, 2, 3, 4 and A. A setting of "0" is manual reset and a setting of "A" is continuously automatic reset.

PWS - PWS (power scale) is the range setting for the LP setting.
1=0.01 - 0.99 KW; 2=1.00 - 9.95 KW; 3=10.0 - 99.5 KW; 4=100 - 650 KW
5=0.01 - 1.30 HP; 6=1.34 - 13.3 HP; 7=13.4 - 133.0 HP; 8=134 - 871 HP
Settings 1-4 will allow the LP setting to display in KW.
Settings 5-8 will allow the LP setting to display in HP.

OPT1- Linear overcurrent trip delay (2-60 seconds). This programming position is used only if the TC



www.SymCom.com

...your electronic control & protection specialists

(605) 348.5580 / (800) 843.8848 / Fax (605) 348.5685

customerservice@symcom.com / technicalsupport@symcom.com

Programmable Pump Protection - Model 77C-KW/HP

Low-Range Programmable Pump Protection - Model 77C-LR-KW/HP

INSTALLATION INSTRUCTIONS

position is set to LIn. This setting will determine the period of time that will expire before tripping on overcurrent, after the amperage exceeds the OC setting.

OPT2- RD2 & RD3 time units programming. This position sets the time units used by the RD2 and RD3 timers. (e.g., RD2 = 10, RD3 = 20; OPT2 = 2 from Table 3 below, RD2 = 10 seconds and RD3 = 20 minutes.)

Setting	RD2	RD3
0	Minutes	Minutes
1	Minutes	Seconds
2	Seconds	Minutes
3	Seconds	Seconds

Table 3: OPT2 Settings

Trip Class	Application Description
5	Small fractional horsepower motors where acceleration times are almost instantaneous or where extremely quick trip times are required.
10	(Fast Trip) Hermetic refrigerant motors, compressors, submersible pumps and general purpose motors that reach rated speed in less than 4 seconds.
15	Specialized applications.
20	(Standard Trip) Most NEMA-rated general purpose motors will be protected by this setting.
30	(Slow Trip) Motors with long acceleration times (>10 seconds) or high inertia loads.
J Prefix	Programming any of the trip classes with the J Prefix will enable jam protection. This additional protection is enabled 1 minute after the motor starts and provides a 2 second trip time for motors exceeding 400% of the OC setting, regardless of trip class.
LIn	Programming the trip class to LIn disables the normal trip classes shown above and enables a linear trip delay on overcurrent. The linear trip delay is set in program position OPT1.

Table 4: Trip Class Table

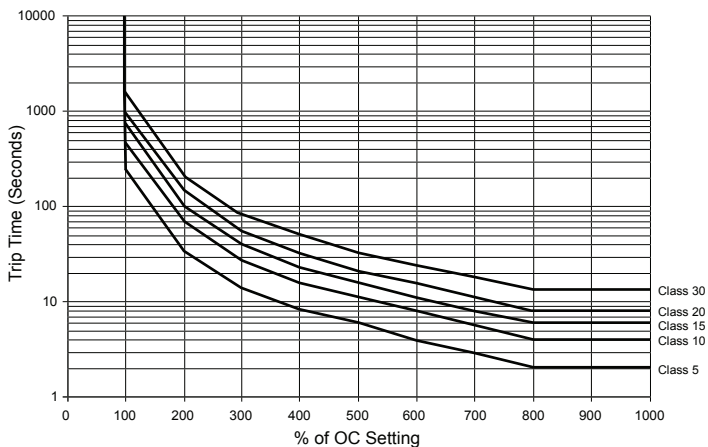

Table 5: Overload Trip Curves



Programmable Pump Protection - Model 77C-KW/HP

Low-Range Programmable Pump Protection - Model 77C-LR-KW/HP

INSTALLATION INSTRUCTIONS

MULTI-FUNCTION SYSTEM DISPLAY

The output display shows system operating parameters L1-L2 Voltage and L2 Current (B). When MODE SELECT is in the RUN position, the LED will display one of the above operating parameters. To select or change the displayed parameter, turn the DISPLAY / PROGRAM knob to the desired position as shown on its label.

The multifunction display is used for programming purposes and also announces system faults such as low voltage and high voltage. Any time MODE SELECT is in the RUN position, the RESET/PROGRAM button may be pushed to view the last fault which occurred. Table 6 below shows the possible messages.

Displayed Message	Meaning
oc	Tripped on Overcurrent
LPR	Tripped on Low Power
HI	High Voltage (won't allow the motor to start)
Lo	Low Voltage (won't allow the motor to start)
oFF	A stop command was issued from a remote source.

Table 6: Output Displays

OPERATION

Once the power monitor has been programmed, turn the MODE SELECT to the RUN position. The LED display will flash RUN alternatively with a number representing the parameter indicated by the DISPLAY / PROGRAM knob. After the period of time programmed into RD1, the output contacts will close and the value of the parameter indicated by the DISPLAY / PROGRAM knob will appear on the LED display. If a message other than those indicated above is shown on the LED display, see the Troubleshooting Chart in Table 7 below to diagnose the problem.

Problem	Solution
The unit will not start. Display alternates "HI" or "Lo" with the DISPLAY/PROGRAM knob parameter value.	The incoming voltage is not within the limits programmed in the HV and LV settings. Adjust the DISPLAY/PROGRAM knob to read the incoming line voltage value. Correct the incoming power problem and check programmed limits to verify they are correct.
Display alternates "oc" with RUN.	The overload relay has tripped on overcurrent and is timing down RD2 before restarting.
Display alternates LPr with RUN.	The overload relay has tripped on low power and is timing down RD3 before restarting.
Display is showing a solid "oc."	The unit has tripped on overcurrent and manual reset is required because of the programmed setting in #RO. Check the system for problems (like a jam) that would produce the overload fault.
Display is showing the solid "LPr."	The unit has tripped on low power and a manual reset is required because of the programmed setting in #RU. Check the system for problems that would produce an underload condition like a dead head or a lack of liquid to the pump.
Unable to change parameters.	See Tamper Guard.

Table 7: Troubleshooting Chart



www.SymCom.com

...your electronic control & protection specialists

(605) 348.5580 / (800) 843.8848 / Fax (605) 348.5685

customerservice@symcom.com / technicalsupport@symcom.com

Programmable Pump Protection - Model 777-P2 / 777-KW/HP-P2
TYPICAL WIRING DIAGRAM

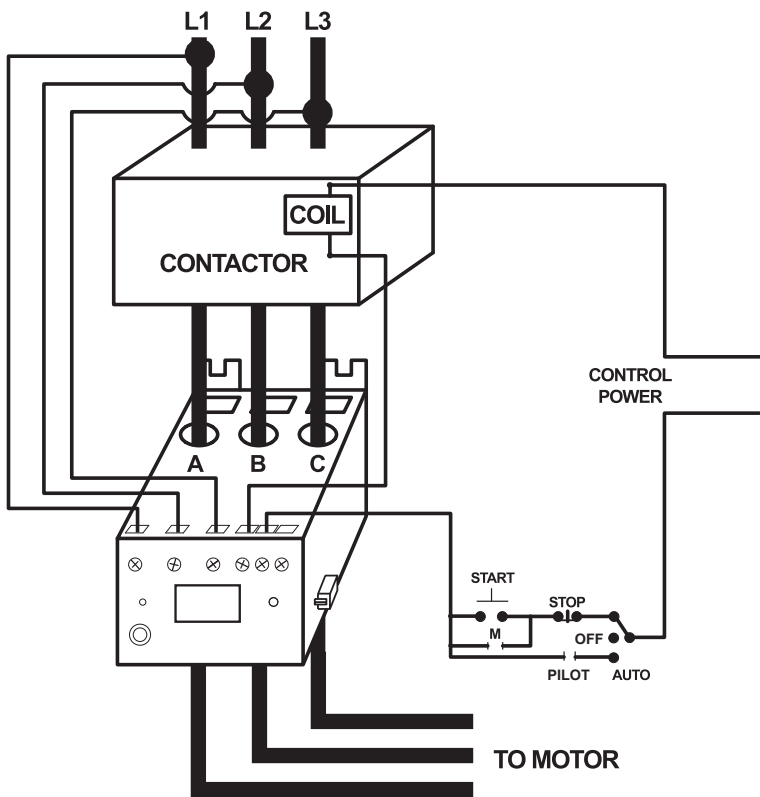

Figure 3: Typical Wiring Diagram for 777-KW/HP-P2



Programmable Pump Protection - Model 777-P2 / 777-KW/HP-P2
 TYPICAL WIRING DIAGRAM

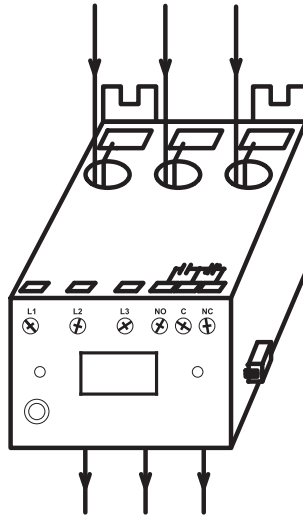

Figure 4: Looping Example

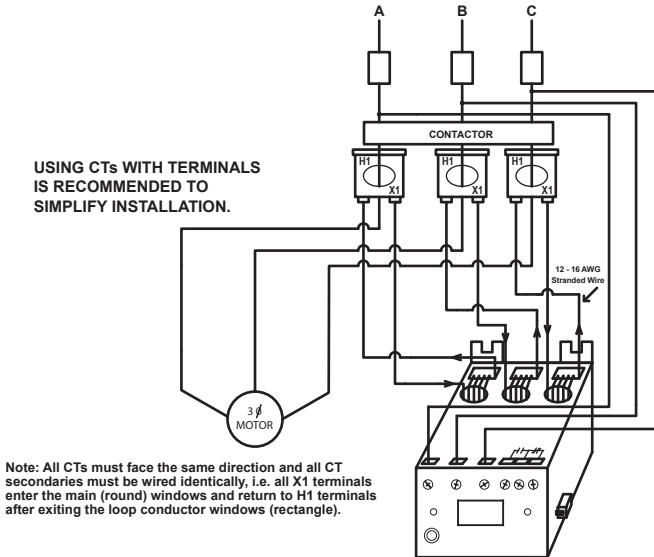

Figure 5: Typical Wiring Diagram using External CTs

Programmable Pump Protection - Model 777-P2 / 777-KW/HP-P2 INSTALLATION INSTRUCTIONS

Recommended Full Load Amps (Amps)	OC Range (Amps)	UC Range (Amps)	# of Passes through each Window	MULT (CT Ratio)
2-2.5	2-10	0, 1-9.8	10	10
2.5-3	2.2-11.1	0, 1.1-10.8	9	9
3-3.5	2.5-12.5	0, 1.2-12.2	8	8
3.5-4	2.8-14.3	0, 1.4-14	7	7
4-5	3.3-16.7	0, 1.6-16.3	6	6
5-6	4-20.1	0, 2-19.6	5	5
6-8	5-25.1	0, 2.5-24.5	4	4
8-12	6.6-33.5	0, 3.3-32.6	3	3
12-20	10-50.3	0, 5-49	2	2
20-90	20-100	0, 10-98	1	1
80-110	80-140	0, 40-140	5	100 (100:5)
110-160	120-210	0, 60-210	5	150 (150:5)
160-220	160-280	0, 80-280	5	200 (200:5)
220-320	240-420	0, 120-420	5	300 (300:5)
320-420	320-560	0, 160-560	5	400 (400:5)
400-520	400-700	0, 200-700	5	500 (500:5)
480-600	480-840	0, 240-840	5	600 (600:5)
540-700	560-980	0, 280-980	5	700 (700:5)
560-800	640-992/FFF	0, 320-992/FFF	5	800 (800:5)

Table 8: Wiring Configuration for 777-P2 & 777-KW/HP-P2 Based on Motor Full Load Amps

Recommended Full Load Amps	OC Range (Amps)	UC Range	# of Passes through each Window	MULT (CT Ratio)
1.0-2.0	1.0-5.0	0, 0.5-4.9	2	2
2.1-9.0	2.0-10.0	0, 1-9.8	1	1
10-25	10-50	0, 5-49	2	25 (50:5)
20-50	20-100	0, 10-98	1	50 (50:5)
30-75	30-150	0, 15-147	1	75 (75:5)
40-100	40-200	0, 20-196	1	100 (100:5)
60-150	60-300	0, 30-294	1	150 (150:5)
80-200	80-400	0, 40-392	1	200 (200:5)
120-300	120-600	0, 60-588	1	300 (300:5)
160-400	160-800	0, 80-784	1	400 (400:5)
200-500	200-999	0, 100-980	1	500 (500:5)
240-600	240-999	0, 120-999	1	600 (600:5)
280-700	280-999	0, 140-999	1	700 (700:5)
320-800	320-999	0, 160-999	1	800 (800:5)

Table 9: Wiring Configuration for 777-LR-P2 & 777-LR-KW/HP-P2 Based on Motor Full Load Amps



www.SymCom.com

...your electronic control & protection specialists

(605) 348.5580 / (800) 843.8848 / Fax (605) 348.5685

customerservice@symcom.com / technicalsupport@symcom.com

Programmable Pump Protection - Model 777-P2 / 777-KW/HP-P2 INSTALLATION INSTRUCTIONS

Recommended Full Load Amps	OC Range (Amps)	# of Passes through each Window	MULT (CT Ratio)
0.5-2.10	0.5-2.7	10	10
0.5-2.3	0.5-3	9	9
0.6-2.6	0.6-3.3	8	8
0.7-3	0.7-3.8	7	7
0.8-3.5	0.8-4.5	6	6
1-4.25	1-5.4	5	5
1.2-5.25	1.2-6.7	4	4
1.6-7	1.6-9	3	3
2.5-10.5	2.5-13.5	2	2
5-21	5-27	1	1
40-90	20-108	5	100 (100:5)
60-135	30-162	5	150 (150:5)
80-180	40-216	5	200 (200:5)
120-270	60-324	5	300 (300:5)
160-360	80-432	5	400 (400:5)
200-450	100-540	5	500 (500:5)
240-540	120-648	5	600 (600:5)
270-630	140-756	5	700 (700:5)
320-740	160-864	5	800 (800:5)

Table 10: Wiring Configuration for 777-MLR-KW/HP-P2 Based on Motor Full Load Amps

PROGRAMMING

To program prior to installation, connect the 9V battery cable to the pins on the left side of the unit (when looking at the display), and then attach a standard 9V battery to the cable. The 9V battery cable is keyed for proper installation. If the cable is connected improperly, the unit will not power its display. DO NOT connect the battery when line voltage is present. The unit cannot be tested for proper operation or communications using a 9V battery. For testing purposes, 3-phase power must be used with a minimum voltage of 200VAC. Follow all safety warnings when dealing with hazardous voltages.

1. Rotate the MODE SELECT switch to the parameter to be programmed. It is recommended that PWS be programmed first on the KW/HP versions.
2. Press and hold the RESET/PROGRAM button.
3. While holding the RESET/PROGRAM button, rotate the DISPLAY/PROGRAM knob until the proper setting for the parameter that is being programmed is displayed.
4. Release the RESET/PROGRAM button. This stores the new parameter in the nonvolatile memory. If the number changes back to what it was before programming, then the tamper guard is on and will need to be unlocked before programming can be completed.
5. Continue steps 1-4 until all parameters are programmed.

PROGRAMMABLE PARAMETERS

The following settings MUST be programmed by the user in order to provide proper protection for the application. Settings vary by situation and application and should be selected and tested for each unique installation. All parameters are actual values except for the VUB and CUB settings; these are programmed as percentages. The range each parameter can be programmed is found in the electrical specifications table. Failure to program all setpoints could result in nuisance tripping or prevent the device from protecting the motor. Always use the proper CTs for the motor full load amperage (FLA).

LV/HV - Low Voltage/High Voltage. The recommended settings for LV (low voltage) and HV (high voltage) according to the NEMA MG1 standard are $\pm 10\%$ of the motor's nameplate voltage. Generally, the motor manufacturer should be contacted to verify these limits. High and low voltage trips are based on average voltage measured. Never set LV higher than HV.



www.SymCom.com

...your electronic control & protection specialists

(605) 348.5580 / (800) 843.8848 / Fax (605) 348.5685

customerservice@symcom.com / technicalsupport@symcom.com

Programmable Pump Protection - Model 777-P2 / 777-KW/HP-P2

INSTALLATION INSTRUCTIONS

Example: Nameplate voltage = 230 V
LV = 90% x 230=207 V
HV = 110% x 230 = 253 V

VUB - Voltage Unbalance. The NEMA MG1 standard says a motor should not be operated above a 1% voltage unbalance without derating the motor. Most utility supplied power sources have a difficult time sustaining a 1% VUB. The motor manufacturer should be consulted for an exact VUB setting. Setting VUB to 999 will disable voltage unbalance protection, but will not disable voltage single-phase protection. Voltage unbalance is calculated as follows:

$$\% \text{Voltage Unbalance} = [(\text{Maximum deviation from the average}) / \text{Average}] \times 100\%$$

Example: Measured line-line voltages = 203, 210, and 212. The average = $(203+210+212)/3 = 208.3$. The maximum deviation from the average is the greatest difference between the average voltage (208.3) and any one voltage reading: $212-208.3 = 3.7$, $210-208.3 = 1.7$ and $208.3-203 = 5.3$. The maximum deviation from the average is 5.3, thus voltage unbalance = $5.3/208.3 \times 100 = 2.5\%$.

MULT - MULT (multiplier) setting is found in Table 8 (Table 9 for -LR version, Table 10 for -MLR version). The MULT setting is determined by the number of passes of the motor leads or the size of external CTs and the full load amps of the motor the unit will be monitoring. MULT sets the trip point range for overcurrent and ground fault current faults. Set MULT first, then set OC and GF.

OC - Overcurrent. Is typically set to the service factor amperage (SFA) of the motor or 100-135% of motor full-load amps (FLA), which are determined by the motor manufacturer. If any one leg exceeds the OC setting, the unit will trip according to the Trip Class (TC) settings.

NOTE: When using external CTs, do not set OC greater than the thermal rating of the CTs

UC - Undercurrent. Is most commonly set to 80% of the full-load amperage (FLA) of the motor. This is usually adequate for protection of loss of load for many pumps and motors, including submersibles. If the motor is drawing less than full load amperage, then the UC may be set lower than 80% of FLA for adequate protection. Centrifugal/booster pumps may have to be set to something higher than 80% of FLA for adequate protection. UC can be set to 0 if UC protection is not desired. The unit examines average current to determine if an undercurrent trip condition exists. The value must be lower than OC. (non -KW/HP versions)

LP - LP (low power) setting is used to shut down the motor or pump on an underload condition (that is based on power instead of solely on current). LP can be set in either kilowatts (kW) or horsepower (hp) as determined by the PWS setting. Setting LP to 0 disables the underload trip feature. (KW/HP versions)

NOTE: PWS must be set before setting LP.

CUB - Current Unbalance. SymCom recommends contacting the motor manufacturer for a specific setting. Current unbalance is calculated the same way voltage unbalance is calculated (see formula above). Setting CUB to 999 will disable current unbalance and current single-phase protection.

TC - Trip Class. Determines how quickly the unit will trip when an overcurrent (overload) condition is detected. TC is a dual-function setting—both a thermal trip class (NEMA standard) and a linear trip delay (in seconds) can be set.

While the standard trip classes are 5, 10, 15, 20, and 30, TC can be set from 2–60, with or without jam protection. The trip class setpoint is the time in seconds that the device will take to trip when any phase



www.SymCom.com

...your electronic control & protection specialists

(605) 348.5580 / (800) 843.8848 / Fax (605) 348.5685
customerservice@symcom.com / technicalsupport@symcom.com

Programmable Pump Protection - Model 777-P2 / 777-KW/HP-P2

INSTALLATION INSTRUCTIONS

current is greater than or equal to 600% of the OC setpoint. These additional “non-standard” trip classes allow the unit to follow a trip curve in-between the “standard” trip class curves shown in Table 5.

Trip classes 2-60 can be set from approximately the 7 o’clock to 10 o’clock position with the DISPLAY / PROGRAM knob. Trip classes J02-J60, which include jam protection, can be set from approximately the 10 o’clock to 1 o’clock position. This additional jam protection feature, when enabled, is initiated 1 minute after the motor starts and provides a 2-second trip delay for motors exceeding 400% of the OC setting.

The linear overcurrent trip delay can be set from approximately the 1 o’clock to 5 o’clock position from 0-60 seconds (L00-L60) or to “oFF.” If TC is set to L00, the unit will trip off within 1 second after motor current reaches the OC setpoint. If both trip class and linear trip delay settings are programmed, the unit will follow the faster trip time. For example, TC is set to J15 and L20, and the amperage is 200% of the OC setting. Following the trip class 15 curve, the unit will trip off in approximately 100 seconds. Thus the unit will follow the linear trip delay setting, because it is faster, and will trip off in 20 seconds.

The motor manufacturer should be contacted for an exact TC setting. Table 11 describes the trip classes, and Table 5 shows the trip class curves.

Trip Class	Application Description
5	Small fractional horsepower motors where acceleration times are almost instantaneous or where extremely quick trip times are required
10	(Fast Trip) Hermetic refrigerant motors, compressors, submersible pumps and general-purpose motors that reach rated speed in less than 4 seconds
15	Specialized applications
20	(Standard Trip) Most NEMA-rated general-purpose motors will be protected by this setting
30	(Slow Trip) Motors with long acceleration times (>10 seconds) or high inertia loads
J Prefix (Jam Protection)	Programming any of the trip classes with the J prefix will enable jam protection. This additional protection is enabled 1 minute after the motor starts and provides a 2 second trip time for motors exceeding 400% of the OC setting
Non-Standard Trip Classes	Trip time in seconds when any phase current is 600% of OC. Time is approximately 90% of the TC setting

Table 11: Trip Classes

RD1 - Restart Delay One. Rapid-cycle timer, in seconds (default). The purpose of this timer is to provide protection against short cycling and to allow adequate cool down time between motor starts. This timer is initiated when power is first applied to the unit. If no voltage fault conditions exist, the output relay will energize (the NO will close and the NC will open) as soon as RD1 timer expires. In most cases, this is set to 20-30 seconds. This should provide adequate protection for successive power outages or short cycling caused by other motor controls. This timer is also initiated when motor current goes to zero. Setting RD1 to zero will turn off this feature and ensure that when an alarm circuit is used, an alarm will sound only when there is a fault or power to the unit is lost.

RD2 - Restart Delay Two. Referred to as a motor cool-down timer, in minutes (default). RD2 is used to restart the motor after a trip due to a current unbalance, current single-phasing, or an overcurrent condition. A setting of 5-10 minutes will give most motors adequate time to cool down after an overcurrent condition. The motor manufacturer should be contacted for an exact value.

RD3 - Restart Delay Three. This timer, in minutes (default), only initiates after an undercurrent/low power trip and is referred to as a dry-well recovery timer in pumping applications. This is set according to the time it takes for the well to recharge after pumping dry. This setting varies widely by application and there is no typical setting. RD3 can be set from 2-500 minutes or to A to enable the automatic Dry-Well Recovery Calculator.



Programmable Pump Protection - Model 777-P2 / 777-KW/HP-P2

INSTALLATION INSTRUCTIONS

The Automatic Dry-Well Recovery Calculator allows the unit to automatically select a restart delay based on the run time of the last run cycle before tripping on a low power fault. Table 12 shows the next restart delay vs. run time. In general, a longer run time produces a shorter restart delay. This feature allows the unit to optimize running and rest times automatically.

Run Time	Next Restart Delay (minutes)	Starts/Hr
> 1Hr	6	10
30 min.- 59.99 min.	15	4
15 min.- 29.99 min.	30	2
< 15 min.	60	1

Table 12: Automatic Dry-Well Recovery Timer

#RU/ADDR - Restart Attempts (Underload)/Address. The #RU/ADDR is a dual-function setting. #RU settings are displayed and selected by turning the DISPLAY/PROGRAM knob from approximately the 7 o'clock to 12 o'clock position. ADDR settings are displayed and selected by turning the DISPLAY/PROGRAM knob from approximately the 12 o'clock to 5 o'clock position.

#RU is the number of restarts the unit will attempt after a low power fault before the unit locks out and requires a manual reset. #RU can be set to 0, 1, 2, 3, 4, or A. This counter is cleared one minute after restarting if the unit does not trip again on low power.

If #RU is set to "0", the unit will require manual resetting after all low power faults.

If #RU is set to "A", the unit will always automatically restart after low power faults, once the RD3 timer expires.

ADDR is the R5-485 address of the unit and is only used when communicating with any external communication device. The address can be set from A01-A99.

#RF/COM - Restart Attempts (other faults)/ Communications Settings. The #RF settings are displayed and selected by turning the DISPLAY/PROGRAM dial from approximately the 7 o'clock to 12 o'clock position. COM settings are displayed and selected by turning the DISPLAY/PROGRAM dial from approximately the 12 o'clock to 5 o'clock position.

#RF is the number of restarts the unit will attempt after current unbalance or current single-phase faults before the unit locks out and requires a manual reset. This counter will be cleared one minute after start-up if the unit does not trip again for the same fault condition. Available settings are 0, 1, 2, 3, 4 and A, or to include overcurrent faults, #RF can be set to oc1, oc2, oc3, oc4 or ocA.

If #RF is set to "0", the unit will require manual resetting after all current unbalance, current single-phase and overcurrent faults.

If #RF is set to "A", the unit will always restart automatically after current unbalance and current single-phase faults, once the RD2 timer expires. Overcurrent faults will require a manual reset.

If #RF is set to "ocA", the unit will always restart automatically after current unbalance, current single-phase and overcurrent faults, once the RD2 timer expires.

COM determines the baud rate, even/odd parity, and stop bit. COM can be set to C00-C07. C00 and C04 are duplicates provided for backward compatibility.

- C00 = 9600 baud, No parity, and 1 stop bit
- C01 = 9600 baud, Odd parity, and 1 stop bit
- C02 = 9600 baud, No parity, and 1 stop bit
- C03 = 9600 baud, Even parity, and 1 stop bit
- C04 = 19200 baud, No parity, and 1 stop bit



www.SymCom.com

...your electronic control & protection specialists

(605) 348.5580 / (800) 843.8848 / Fax (605) 348.5685
customerservice@symcom.com / technicalsupport@symcom.com

Programmable Pump Protection - Model 777-P2 / 777-KW/HP-P2

INSTALLATION INSTRUCTIONS

- C05 = 19200 baud, Odd parity, and 1 stop bit
- C06 = 19200 baud, No parity, and 1 stop bit
- C07 = 19200 baud, Even parity, and 1 stop bit

PWS - Power Scale. The PWS setting for the respective LP range is shown in Table 13 below. Settings 1-4 will allow the LP setting to display in kW. Settings 5-8 will allow the LP setting to display in hp. (KW/HP versions)

PWS Setting	LP Range
1	0.01 - 0.99 kW
2	1.00 - 9.95 kW
3	10.0 - 99.5 kW
4	100 - 650 kW
5	0.01 - 1.30 hp
6	1.34 - 13.3 hp
7	13.4 - 133.0 hp
8	134 - 871 hp

Table 13: PWS

UCTD - Undercurrent Trip Delay. The length of time, in seconds (default), the unit will allow the motor to run in an undercurrent situation before de-energizing its relay. Typically, UCTD is set to 2-4 seconds to allow for motor to reach full load. (non KW/HP version)

GF - Ground Fault. The maximum allowable current that can flow to ground before the unit de-energizes its relay. This is a residual, class II ground fault system and should not be used for personnel safety. A typical setting for GF is 10-20% of motor FLA (in amps). GF may be set to OFF if this feature is not desired. The GF test procedure in this installation instruction manual must be conducted before the device is brought online.

OPERATION

The relay operation of the units are designed to be fail-safe. This means when the voltage is within the programmed limits, the relay will energize – the NO contact will close and the NC contact will open. When the unit loses power or senses a fault condition, the relay will de-energize and contacts will return to their original state. Once the unit has been installed and programmed, the unit is ready to operate. Turn MODE SELECT to the RUN position. The display will show “run” alternating with a number (the number displayed will be the number corresponding to where the DISPLAY/PROGRAM knob is pointed). It will do this for the restart delay time programmed into RD1. Once the timer expires, the relay will energize – the NO contact will close and the NC contact will open. If something other than this is displayed, see the troubleshooting section on page 50 for more information. If MODE SELECT is taken out of RUN, the unit’s relay will de-energize.



www.SymCom.com

...your electronic control & protection specialists

(605) 348.5580 / (800) 843.8848 / Fax (605) 348.5685

customerservice@symcom.com / technicalsupport@symcom.com

Programmable Pump Protection - Model 777-P2 / 777-KW/HP-P2

INSTALLATION INSTRUCTIONS

SYSTEM DISPLAY

On power up, the unit will show the current software revision. For example if the software revision is 33.04, the unit will show 033 followed by 004.

The output display can show one of the following parameters when MODE SELECT is in RUN: L1-L2, L2-L3, and L3-L1 line voltage; %VUB; A, B, and C phase current; %CUB; measured GF current, KW, HP. The display is used for programming the operating parameters of the device and also identifies what caused the unit to de-energize its relay or what is keeping the unit from energizing its relay, and under normal operating conditions, what the last fault was. The last fault can be displayed by pressing and holding the RESET/PROGRAM button while MODE SELECT is in RUN. When the unit trips off or is holding the motor off, the current fault condition will be shown in the display without pressing the button (CAUTION: pressing the reset button at this time will reset the unit). Table 14 lists the fault codes the unit could display.

Displayed Message	Meaning
oc	Tripped on overcurrent
SP	Tripped on current single-phasing or unit won't start because the voltage is single-phased
ub	Tripped on current unbalance or unit won't start because the voltage is unbalanced
uc	Tripped on undercurrent
CF	Tripped on contactor failure (due to faulty contacts or connections on the load side)
GrF	Tripped on ground fault
HI	A high voltage condition exists (won't allow motor to start)
Lo	A low voltage condition exists (won't allow motor to start)
rP	Incoming phases have been reversed, the motor may run backwards if started
oFF	A stop command was issued from a remote source
HP _r	Tripped on high power
LP _r	Tripped on low power
CL _o	Tripped on low control voltage
clr	No previous faults
Pro	Shown when programming using the battery in the RUN position
FFF	Displayed value is greater than 999 (can be due to incorrect MULT setting)

Table 14: Fault Codes



www.SymCom.com

...your electronic control & protection specialists

(605) 348.5580 / (800) 843.8848 / Fax (605) 348.5685

customerservice@symcom.com / technicalsupport@symcom.com

Programmable Pump Protection - Model 777-P2 / 777-KW/HP-P2

INSTALLATION INSTRUCTIONS

TROUBLESHOOTING

The unit will display a fault code alternating with a number or with "run" when it has tripped. If the unit is showing a fault code alternating with "run," it is timing down the restart delay. If the fault code is alternating with a number (voltage reading or zero), the unit will not allow the motor to start because there is a problem with the incoming voltage. If the display is showing just a fault code, the unit is in a manual reset mode. This could be because the number of restarts (#RF, #RU) has expired or is not allowed. If the display reads "oFF," a stop command was issued through the communications network or a remote monitor.

PROBLEM	SOLUTION
The unit will not start. Display alternates "rP" with the DISPLAY/PROGRAM parameter value.	The voltage inputs are reverse-phased. If this is the initial start-up, swap any two of the leads connected to L1, L2, or L3 on the unit to correct the problem. If the unit has been previously running, the power system has been reverse-phased. Check the phase sequence of the incoming power lines. Note: L1 must be tapped from conductor Phase A, L2 from B, and L3 from C for correct power factor measurements on remote communications.
The unit will not start. Display alternates "SP", "ub", "HI", or "Lo" with the DISPLAY/PROGRAM parameter value.	The incoming voltage is not within the limits programmed in the VUB, HV, and LV settings. Turn the DISPLAY / PROGRAM knob to read each incoming line voltage value. Correct the incoming power problem and check programmed limits by turning the MODE SELECT knob. Compare incoming values for HV, LV, and VUB to setpoints to verify they are correct.
Display alternates "SP", "ub", or "oc" with "run."	The unit has tripped on the fault shown on the display and is timing down RD2 before restarting. No further action is required.
Display alternates "uc" with "run."	The unit has tripped on undercurrent and is counting down RD3 before restarting.
Display is showing a solid "SP", "ub", or "oc."	The unit has tripped on the fault shown and a manual reset is required because of the programmed setting in #RF. Check the system for problems that would produce the single-phase, overcurrent or current unbalance fault, such as a jam.
Display is showing a solid "uc."	The unit has tripped on undercurrent and a manual reset is required because of the setting in #RU. Check the system for problems that would produce an undercurrent condition like a dead head or a lack of liquid to the pump.
Display is showing a solid "CF."	The unit has tripped on current single-phasing, but was not single-phased by the incoming voltage. Check for damaged contacts or loose or corroded wiring connections.
Display is showing a solid "GrF."	A ground fault current greater than the programmed GF value has been detected. Check the motor for insulation breakdown. A manual reset is required to clear this message. Press the RESET/PROGRAM button to perform a manual reset.
Display alternates "LPr" with "RUN"	The unit has tripped on low power (LPr) and is timing down RD3 before restarting.
Display is showing a solid "LPr"	The unit has tripped on low power and a manual reset is required because of the setting in #RU. Check the system for problems that would produce a loss of load or a pump is out of liquid. Press the RESET/PROGRAM button to perform a manual reset.
Display alternates "HPr" with "RUN"	The unit has tripped on high power and is timing down RD2. Check for a high power condition.
Display is showing solid "HPr"	The unit has tripped on high power and requires a manual reset because of the setting in #RF. Press the RESET/PROGRAM button to perform a manual reset.
Display alternates "CLo" with "RUN"	The unit has tripped on low control voltage (CLo) and is timing down RD2 before restarting.
Display is showing solid "CLo"	The unit has tripped on low control voltage and a manual reset is required because of the setting in #RF. Verify system voltage is correct. Press the RESET/PROGRAM button to perform a manual reset.



www.SymCom.com

...your electronic control & protection specialists

(605) 348.5580 / (800) 843.8848 / Fax (605) 348.5685

customerservice@symcom.com / technicalsupport@symcom.com

Liquid Level Sensor - Model 460-15-100-LLS

INSTALLATION INSTRUCTIONS

OPERATION

When a conductive liquid makes contact with the probe it will cause the relay to change state after the debounce time is satisfied. The Run LED indicates that liquid is not present, and the Stop LED indicates that liquid is present.

SETTINGS

1. Debounce Adjustment:

This adjusts the amount of time that a conductive liquid is in contact with the probe before the relay changes state. Note: If the time dial is changed, the new setting will take effect immediately, minus any time that has already elapsed.

2. Logic Jumper:

Logic Jumper Installed: Relay closes when conductive liquid is in contact with the probe.

Logic Jumper Removed: Relay opens when conductive liquid is in contact with the probe.

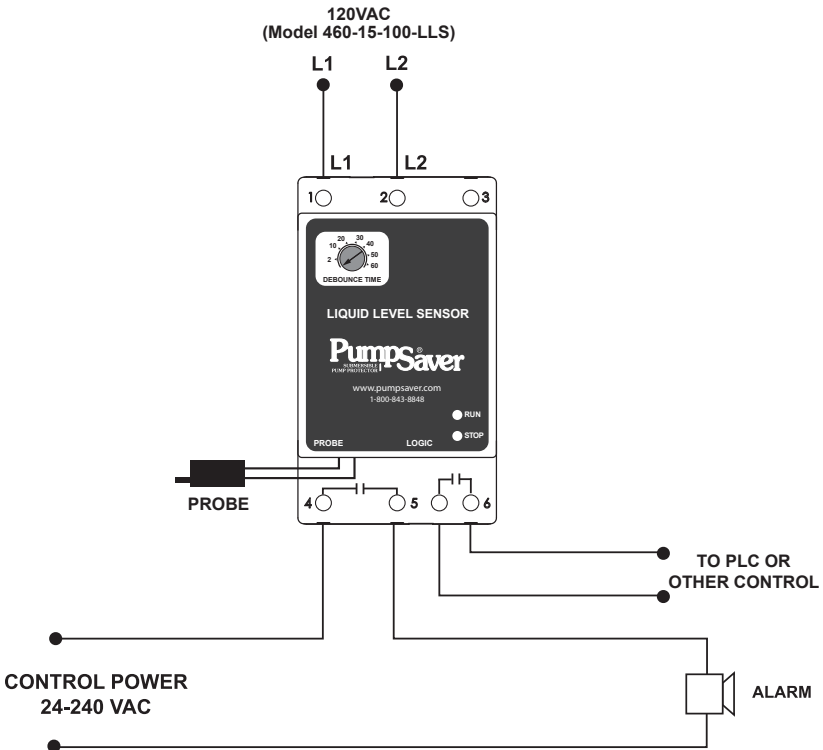

Liquid Level Control - Model PC-xxx-LLC-CZ

INSTALLATION INSTRUCTIONS

CONNECTIONS for PC-XXX-LLC-CZ

1. The PC-XXX-LLC-CZ requires an 8-pin socket, part number OT08-PC (sold separately).
2. Mount the PumpSaver® socket in a convenient location in or near the pump control panel. If the location is wet or dusty, it should be mounted in a NEMA 4 or 12 enclosure.
3. For pump motor control, connect the normally open contact, socket terminal 3, and common, socket terminal 1, in series with the motor's magnetic contactor coil (M).
4. Connect the power supply L1 to socket terminal 2 and power supply L2 to socket terminal 7.
5. Connect high level probe to socket terminal 6.
6. Connect low level probe to socket terminal 8.
7. If the tank is conductive, connect a probe common wire between the tank and socket terminal 5. If the tank is not conductive, a wire must be connected between a reference, or common, probe and socket terminal 5.
8. Plug the PumpSaver® into the socket.

Note: The PC-XXX-LLC-CZ uses a 5vdc pulse to check the resistance of each probe, so the probes must be isolated from other voltage sources.

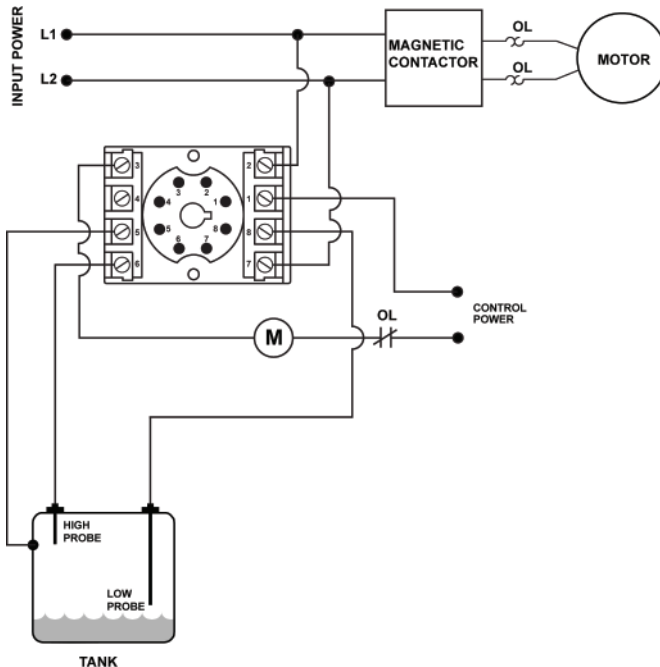

Liquid Level Control - Model PC-xxx-LLC-GM INSTALLATION INSTRUCTIONS

CONNECTIONS for PC-XXX-LLC-GM

1. The PC-XXX-LLC-GM requires an 8-pin socket, part number OT08-PC (sold separately).
2. Mount the PumpSaver[®] socket in a convenient location in or near the pump control panel. If the location is wet or dusty, it should be mounted in a NEMA 4 or 12 enclosure.
3. For pump motor control, connect the normally open contact, socket terminal 6, and common, socket terminal 8, in series with the motor's magnetic contactor coil (M).
4. Connect the power supply L1 to socket terminal 1 and power supply L2 to socket terminal 2.
5. Connect high level probe to socket terminal 3.
6. Connect low level probe to socket terminal 1.
7. If the tank is conductive, connect a probe common wire between the tank and socket terminal 5. If the tank is not conductive, a wire must be connected between a reference, or common, probe and socket terminal 5.
8. Plug the PumpSaver[®] into the socket.

Note: The PC-XXX-LLC-GM uses a 5vdc pulse to check the resistance of each probe, so the probes must be isolated from other voltage sources.

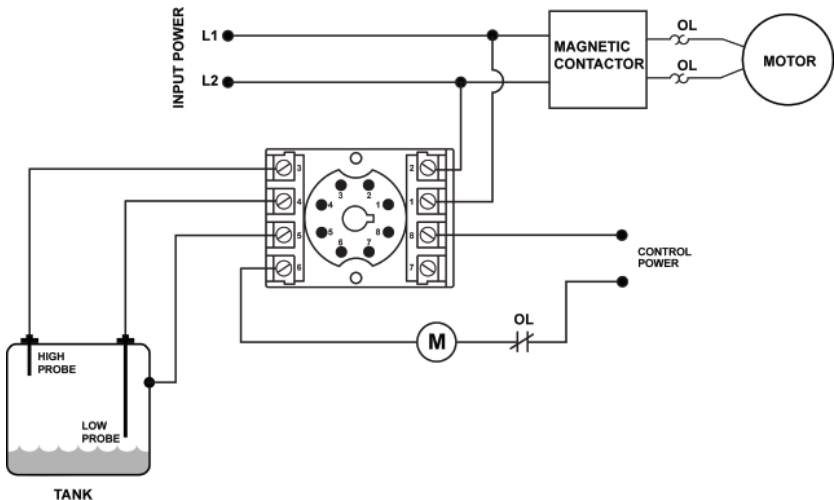

111P / 233P / 235P & ENCL enclosure - DIMENSIONS

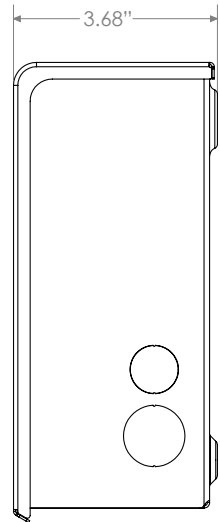
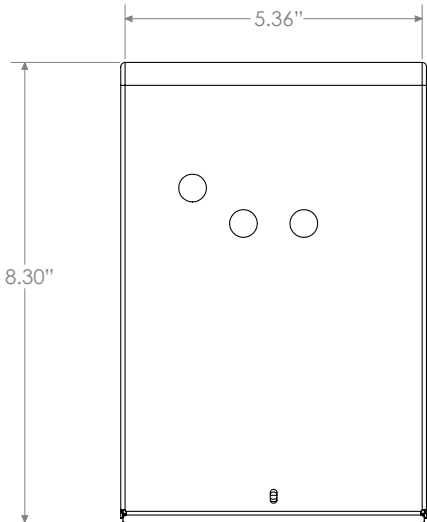
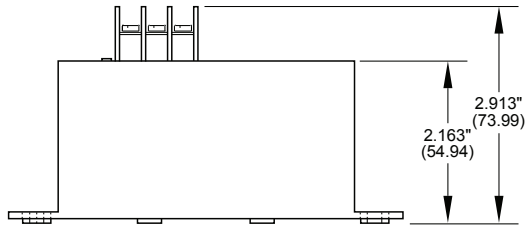
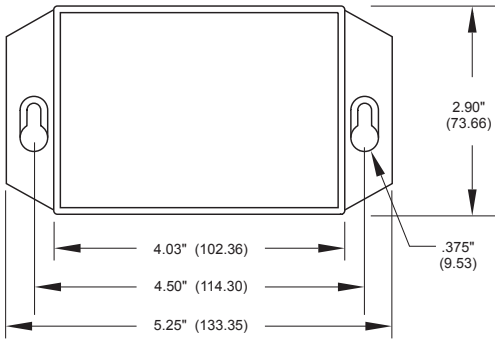

www.SymCom.com

...your electronic control & protection specialists

(605) 348.5580 / (800) 843.8848 / Fax (605) 348.5685

customerservice@symcom.com / technicalsupport@symcom.com

77C-KW/HP / 777-P2 / 777-KW/HP-P2 - DIMENSIONS

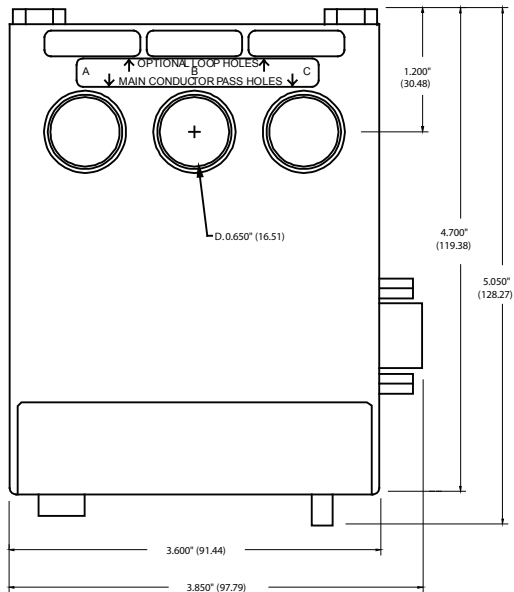
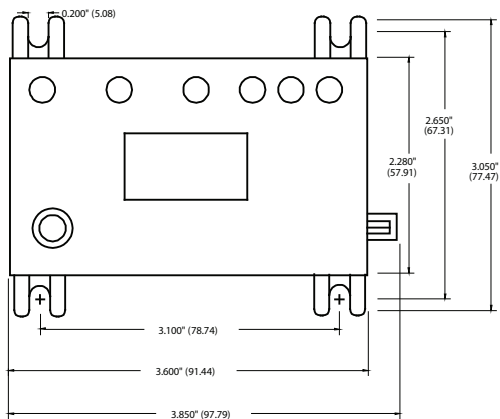

www.SymCom.com

... your electronic control & protection specialists

(605) 348.5580 / (800) 843.8848 / Fax (605) 348.5685

customerservice@symcom.com / technicalsupport@symcom.com

PC-xxx-LLC-CZ/GM / 460-15-100-LLS - DIMENSIONS

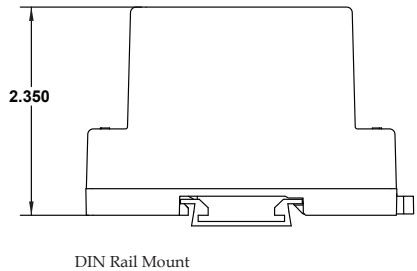
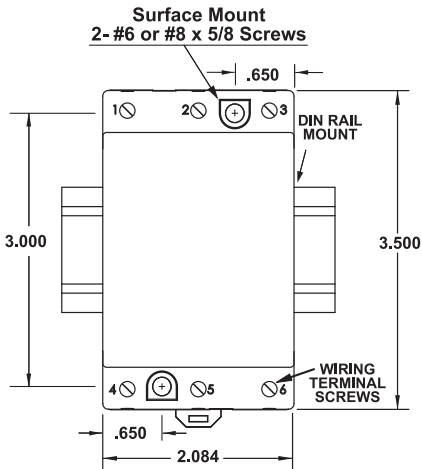
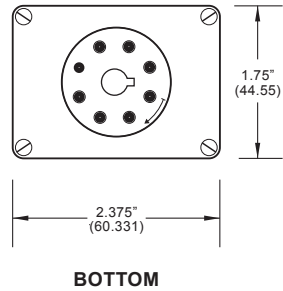
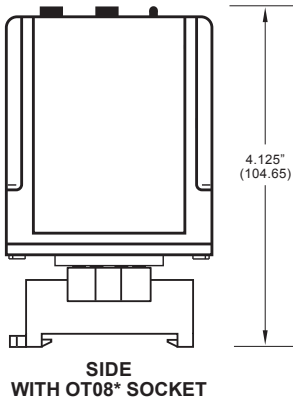

Voltage/Current/Power Monitors - Overload Relays

SymCom's 777 family of products are UL listed as Electronic Overload Relays. The KW/HP units are also power monitors that can calculate a Power reading for use with many software solutions.

Communication & I/O Modules

Units that are used for converting the information coming from a 777 family or 601 family product to Modbus, Devicenet, 4-20mA or Profibus signal to be sent over a network.

Remote Monitors

SymCom's remote monitors are used in conjunction with the 777 and 601 families to display real-time voltages and currents. Fault codes are listed on an easy to read display. Using a remote monitor will also help by making it safer for employees to gather real-time information without having to open the electrical panel.

Solutions Software

Used to monitor, log information, control and change configurations and setpoints on the 777 and 601 family of products.

Voltage Monitors, single-phase & 3-phase

Used to monitor incoming line voltages for High or Low voltage, Reverse-phase, Unbalanced voltage and Single-Phased voltages.

Current Monitors, single-phase & 3-phase

Used to monitor current levels in a motor for High or Low current, Unbalanced current and Single-Phased currents.

Alternating Relays

Unit will alternate between two pumps so they will have equal running time, thus not wearing one pump out prematurely.

Intrinsically-Safe Relays

Units designed to be used in hazardous applications where explosive materials are present.

Pump Controllers

Used to control from 2 to 4 pumps in multiple pump applications. Has the ability to be used in pump-up or pump-down configurations. Different models have multiple uses. SymCom also provides Intrinsically-Safe pump controllers.

Load Sensors

Can be used as proof relays to detect tool wear, feed rates and loss of prime on pumps by detecting current levels. Many different configurations can be used for differing uses.

Auxiliary Products

TIMERS - On-delay timer that starts its timer when power is applied. Output contact is energized when the timing is complete, anywhere from 6 seconds to 10 minutes or 0.5 to 12 seconds.

CURRENT TRANSFORMERS - Donut or foot mounted CT used for transmitting current signal from the main conductors to the SymCom units where required.

For warranty information,
please see **Terms and Conditions** at
www.symcom.com



2880 North Plaza Drive, Rapid City, SD 57702
(800) 843-8848 • (605) 348-5580 • fax: (605) 348-5685
customerservice@symcom.com • technicalsupport@symcom.com